

# INSTALLATION MANUAL

## 35-4017

### Level of Difficulty

Easy

### Parts List

1	Bull bar
1	Driver / left mounting bracket
1	Passenger / right mounting bracket
4	Hex head cap screw, M10 x 30mm
8	Flat washer, M10
4	Nylon lock nut, M10
6	Flat washer, M12
6	Nylon lock nut, M12
2	Double bolt plate, 12mm x 30mm
2	Single bolt plate, 12mm x 35mm

### Tools Required

Socket set      Box wrench

### Torque Specifications

M10 bolt	16 ft-lbs.
M12 bolt	28 ft-lbs.

Use above torque setting unless otherwise noted

### Product Registration and Warranty

CURT Group stands behind our products with industry-leading warranties. Provide feedback and help us to improve our products by registering your purchase at: [warranty.curtgroup.com/surveys](http://warranty.curtgroup.com/surveys)

### Product Photo



### Brackets and Hardware

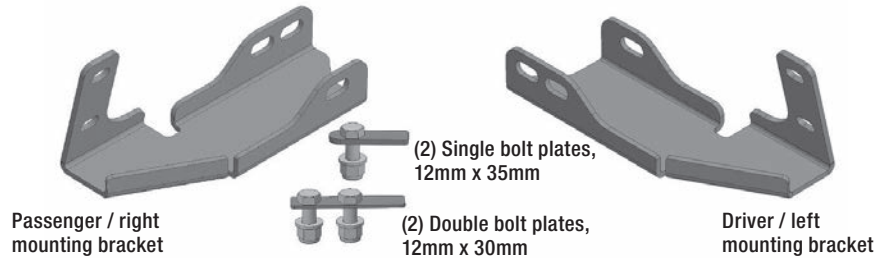

### NOTICE

Before you begin installation, read all instructions thoroughly.

Proper tools will improve the quality of installation and reduce the time required.

To help prevent damage to the product or vehicle, refer to the specified torque specifications when securing hardware during the installation process.

### Maintenance

To protect the product, wax after installing. Regular waxing is recommended to add a protective layer over the finish. Do not use any type of polish or wax that may contain abrasives that could damage the finish.

For polished, gloss and other smooth finishes, polish may be used to clear small scratches and scuffs on the finish.

Mild automotive detergent may be used to clean the product. Do not use dish detergent, abrasive cleaners, abrasive pads, wire brushes or other similar products that may damage the finish.

## PROCEDURE:

**REMOVE CONTENTS FROM BOX AND VERIFY ALL PARTS ARE PRESENT. READ INSTRUCTIONS CAREFULLY. CUTTING MAY BE REQUIRED. INSTALLATION MAY INTERFERE WITH FRONT MOUNTED SENSORS. NOTE:** It may be necessary to remove/relocate front license plate and license plate bracket. It is not required, but strongly recommended. If local/state law requires a front license plate, license plate relocation kit is available.

1. Start installation from under the front of the vehicle. Determine if the vehicle is equipped with tow hooks.  
**IMPORTANT:** Tow hooks cannot be reinstalled with the Bull Bar.

### **Tow Hook equipped vehicles:**

- a. Remove the factory tow hook from the end of each frame channel, **(Figures 1—3)**.
- b. Select the passenger/right Mounting Bracket. Insert the Bracket through the opening in the bumper and up to the frame. Trim the plastic as required to clear the Bracket, **(Figure 5)**. Repeat to check for clearance on driver/left side of bumper.
- c. Proceed to **Step 2**.

### **Vehicles without tow hooks:**

- a. Cut out the indented area in both sides of the plastic bumper insert to clear the Brackets as pictured, **(Figures 4 & 5)**. **IMPORTANT:** Make several small cuts for best fit.
  - b. Check for clearance between Brackets and opening and trim the plastic as required to clear the Brackets.
2. Line up the holes in the Bracket with the holes in the end of the frame channel for the tow hook, **(Figure 5)**. Select (1) 12mm Double Bolt Plate, **(Figure 6)**. Insert the Bolt Plate into the end of the frame and out through the (2) holes in the side of the frame and out through the Bracket, **(Figures 6 & 8)**. Secure the Bracket to the Bolt Plate with (2) 12mm Flat Washers and (2) 12mm Nylon Lock Nuts. Leave hardware loose at this time.
  3. Repeat **Step 2** to install the 12mm x 35mm Single Bolt Plate, **(Figure 9)**, into the single forward tow hook mounting hole in the other side of the frame channel and Bracket, **(Figures 6, 10 & 11)**.
  4. Repeat **Steps 2 & 3** to install the driver/left Mounting Bracket.
  5. With assistance, hold the Bull Bar up in position on the outside of the Mounting Brackets. Attach the Bull Bar to the Brackets with (4) 10mm x 30mm Hex Bolts, (8) 10mm Flat Washers and (4) 10mm Nylon Lock Nuts, **(Figures 12 & 13)**. Do not tighten hardware at this time.
  6. Check the Bull Bar alignment with the vehicle and for clearance between the Bull Bar and the bumper. Adjust as required then fully tighten all hardware at this time.
  7. Do periodic inspections to the installation to make sure that all hardware is secure and tight.

**To protect your investment**, wax this product after installing. Regular waxing is recommended to add a protective layer over the finish. Do not use any type of polish or wax that may contain abrasives that could damage the finish.

**For stainless steel:** Aluminum polish may be used to polish small scratches and scuffs on the finish. Mild soap may be used also to clean the Bull Bar.

**For gloss black finishes:** Mild soap may be used to clean the Bull Bar.

## Passenger/right Side Installation Pictured



**(Fig 1) Example of Tow hook**

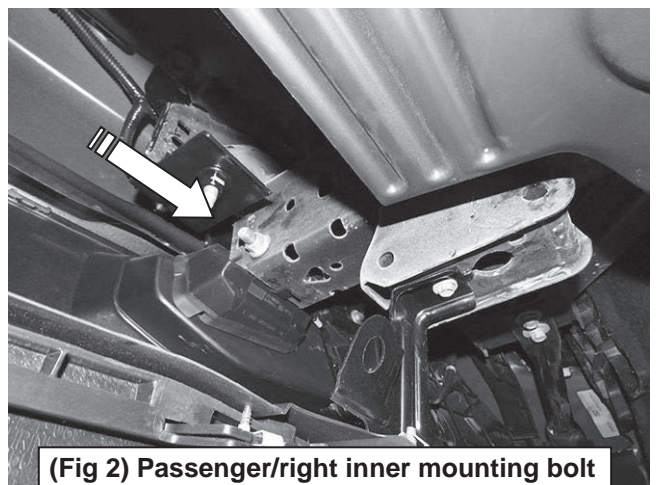

**(Fig 2) Passenger/right inner mounting bolt for tow hook pictured from behind bumper**

**Passenger/right Side Installation Pictured**

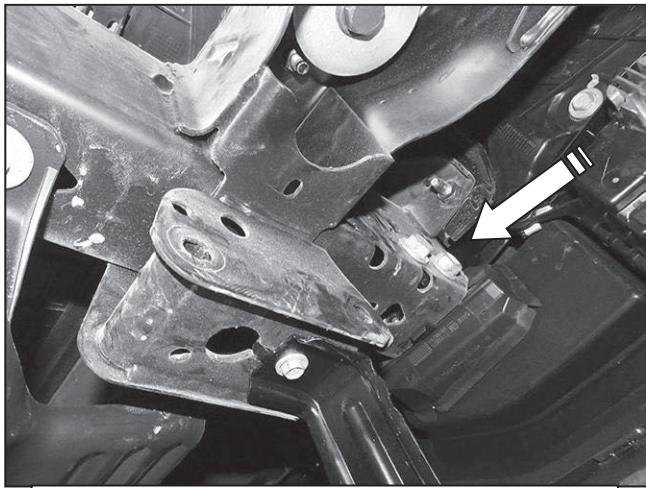

**(Fig 3) Passenger/right outer mounting bolts for tow hook pictured from behind bumper**

Area to cut out illustrated for example only

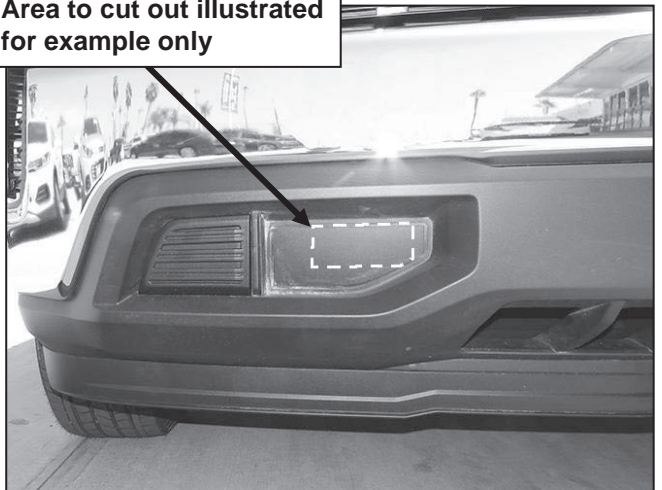

**(Fig 4) Example of model without tow hooks**

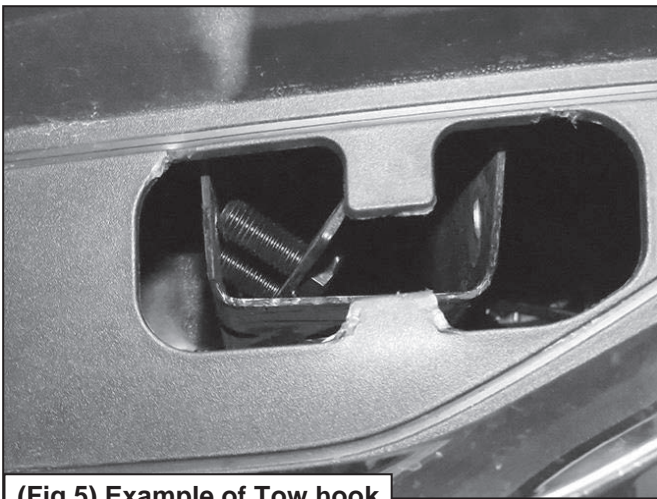

**(Fig 5) Example of Tow hook**

- |                            |                            |
|----------------------------|----------------------------|
| (1) 12mm Double Bolt Plate | (1) 12mm Single Bolt Plate |
| (2) 12mm Flat Washers      | (1) 12mm Flat Washer       |
| (2) 12mm Nylon Lock Nuts   | (1) 12mm Nylon Lock Nut    |

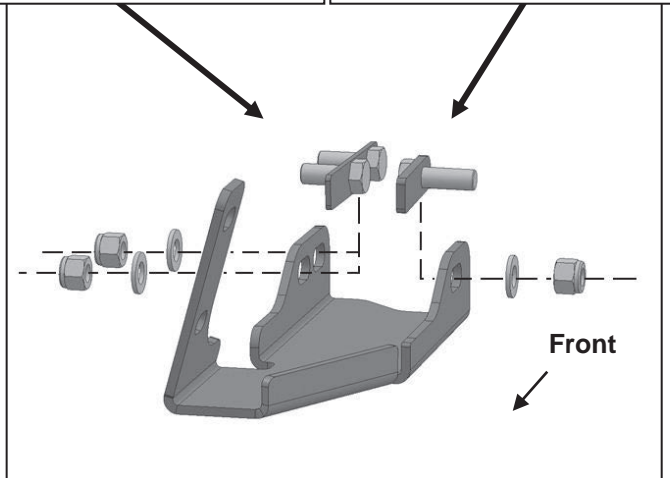

**(Fig 6) Passenger/right side Bracket illustrated**

- 12mm Double Bolt Plate  
 (2) 12mm Flat Washers  
 (2) 12mm Nylon Lock Nuts



**Fig 7**

- (1) 12mm Double Bolt Plate  
 (2) 12mm Flat Washers  
 (2) 12mm Nylon Lock Nuts

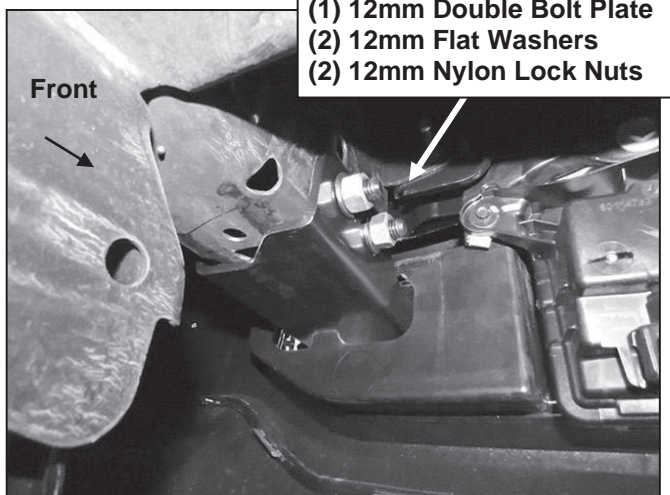

**(Fig 8) Outer passenger/right side Bracket with Double Bolt Plate pictured from behind bumper**

- 12mm Single Bolt Plate  
 12mm Flat Washer  
 12mm Nylon Lock Nut

**Fig 9**

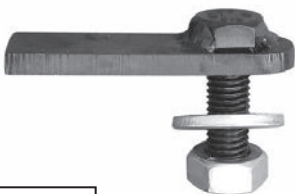



## Passenger/right Side Installation Pictured

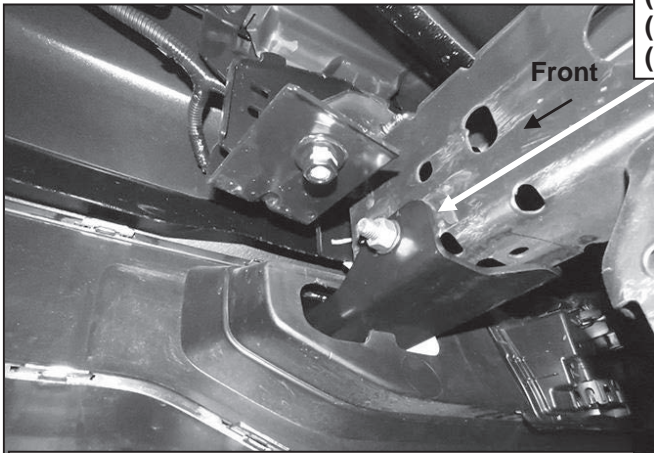

- (1) 12mm Single Bolt Plate
- (1) 12mm Flat Washer
- (1) 12mm Nylon Lock Nut

(Fig 10) Inner passenger/right side Bracket with Single Bolt Plate pictured from behind bumper

- (2) 10mm Hex Bolts
- (4) 10mm Flat Washers
- (2) 10mm Nylon Lock Nuts

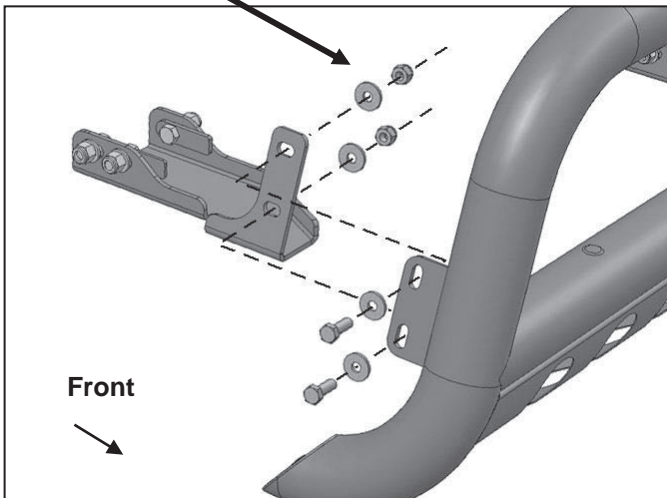

(Fig 12) Attach Tyger Guard to outside of Brackets. Passenger/right side complete installation

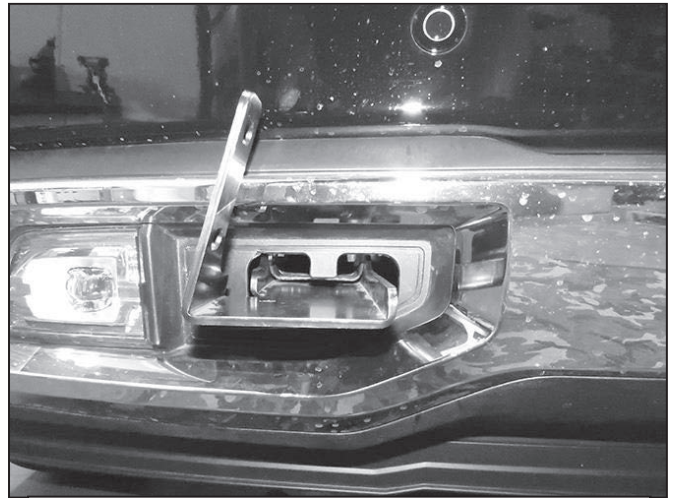

(Fig 11) Passenger/right side Bracket installed

- (2) 10mm x 30mm Hex Bolts
- (4) 10mm Flat Washers
- (2) 10mm Nylon Lock Nuts



(Fig 13) Passenger/right side complete installation