

# POWERED RUNNING BOARDS INSTALLATION MANUAL



## Level of Difficulty

Moderate

## Parts List

1	Driver / left running board*
1	Passenger / right running board*
6	Mounting bracket, universal
6	T-rails
30	Flat washer, M8
18	Nylock nut, M8
18	Flat washer, nylon, 3/8"
12	Nylock nut, 5/16"
2	Rubber grommet
4	Door sensor
2	Door sensor extension
4	Magnet
2	Alcohol wipe
1	Power switch
1	Circuit board
1	Anti-seize
1	Wire loom
1	Wiring harness, two-piece
2	LED light
2	LED light bracket
4	Double-sided foam tape, 3/4" x 3/4"
8	Double-sided foam tape, 1/2" x 1/2"

\* Running boards sold separately

## Tools Required

Ratchet	Drill
Socket set	Drill bit set
Zip ties	Level

## Torque Specifications

Metric	M6 bolt	3 ft.-lbs.
	M8 bolt	7 ft.-lbs.
	M10 bolt	16 ft.-lbs.
SAE	1/4" bolt	3 ft.-lbs.
	5/16" bolt	7 ft.-lbs.
	3/8" bolt	16 ft.-lbs.
	1/2" bolt	28 ft.-lbs.

Use above torque setting unless otherwise noted

## ⚠ WARNING

Improper electrical installation may result in personal injury. Unless you are familiar with the installation and handling of electrical systems, have this step performed by someone who has that familiarity.

## Product Photo



## Powered Running Boards (not included)

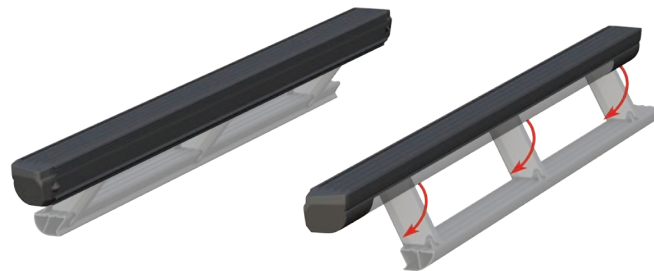

## Part Numbers

3025121 (brackets)	3025183 (boards)	3048321 (brackets & boards)
3015121 (brackets)	3015183 (boards)	3038321 (brackets & boards)

## Notes and Maintenance

Before you begin installation, read all instructions thoroughly.

Proper tools will improve the quality of installation and reduce the time required.

No maintenance required on waterproof harness or water-resistant motors. If mud or dirt is built up on the steps, simply spray them off and let them air dry.

Mild automotive detergent may be used to clean the product. Do not use dish detergent, abrasive cleaners, abrasive pads, wire brushes or other similar products that may damage the finish.

Periodic inspection of all wires and connections should be performed to ensure there is no visible damage or loose connections.

Refer to the last page of this manual for troubleshooting, warranty and product registration information.

Refer to the table to the left when securing hardware during the installation process to help prevent damage to the product or vehicle.

### Step 1

Starting on the driver side, locate the three mounting locations underneath the vehicle.

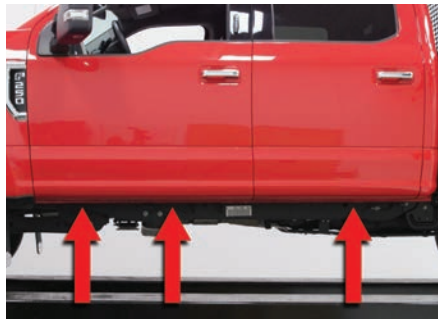

### Step 2

Starting at the front driver-side mounting location, locate three threaded studs on the inside of the body panel and place a 3/8" nylon flat washer over each stud. This will help prevent galvanic corrosion.

Attach the mounting bracket to the vehicle using three M8 flat washers and nylock nuts.

Snug the hardware, but do not fully tighten.



### Step 3

Repeat step 2 for the middle and rear brackets.



#### Step 4

With the driver-side brackets installed, take the driver-side running board and insert three T-rails into the slot as shown.

**Note:** Position each T-rail as close to the mounting bracket location as possible.

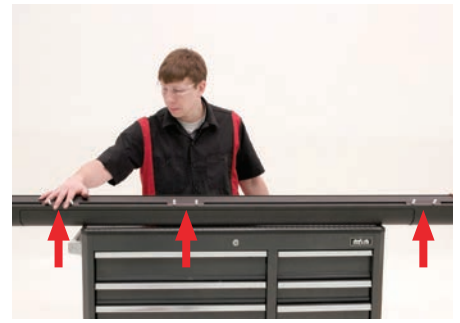

#### Step 5

With help, carefully place the running board onto the mounting brackets.

Align the T-rails with the mounting brackets on the vehicle. Slide the top mounting track on the board over the top flange on each bracket. Adjust the T-rails in the lower track of the board so the studs drop into the slots on the bottom of each mounting bracket.



#### Step 6

Secure the running board to the front mounting bracket using one M8 flat washer and one 5/16" nylock nut on each T-rail stud.

Repeat for the middle mounting bracket.

Before securing the rear mounting bracket, place an LED light bracket over one of the T-rail studs, as shown in the third image. Secure each T-rail stud with one M8 flat washer and one 5/16" nylock nut.

Snug the hardware, but do not fully tighten.



### Step 7

At this time, adjust the running board to the desired location.

With the running board in position, it is recommended to tighten all brackets to the vehicle first, followed by the running board connections.

Repeat steps 1 through 7 on the passenger side.



### Step 8

Remove the fuse from the wiring harness before installing.

Once the fuse is removed, take that section of the wiring harness and attach it to the battery. Route the opposite end of the harness through the firewall into the cab of the vehicle.

Zip-tie the wiring harness in place once it is in the desired location.

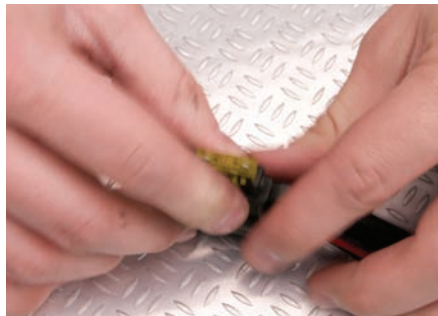
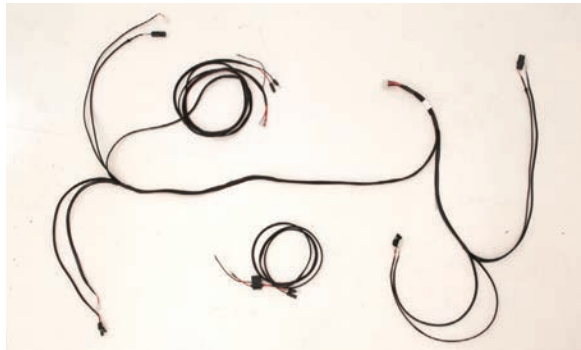



## Step 9

Remove the front and rear door trim panels on both sides of the vehicle.

**Note:** Remove any other vehicle components that could interfere with the wiring harness.



## Step 10

Once the trim panels are removed, take the second section of wiring harness and route it under the carpet, through the vehicle, from the passenger-side rear to the desired location.

Refer to the diagrams below.



### Wiring Locations

	Driver	Passenger
Door sensor, rear	Purple / Orange	White / Blue
Door sensor, front	Yellow / Orange	Grey / Green
LED light	Brown / Dark brown	Pink / Brown
Actuator	Black / Red	Black / Red

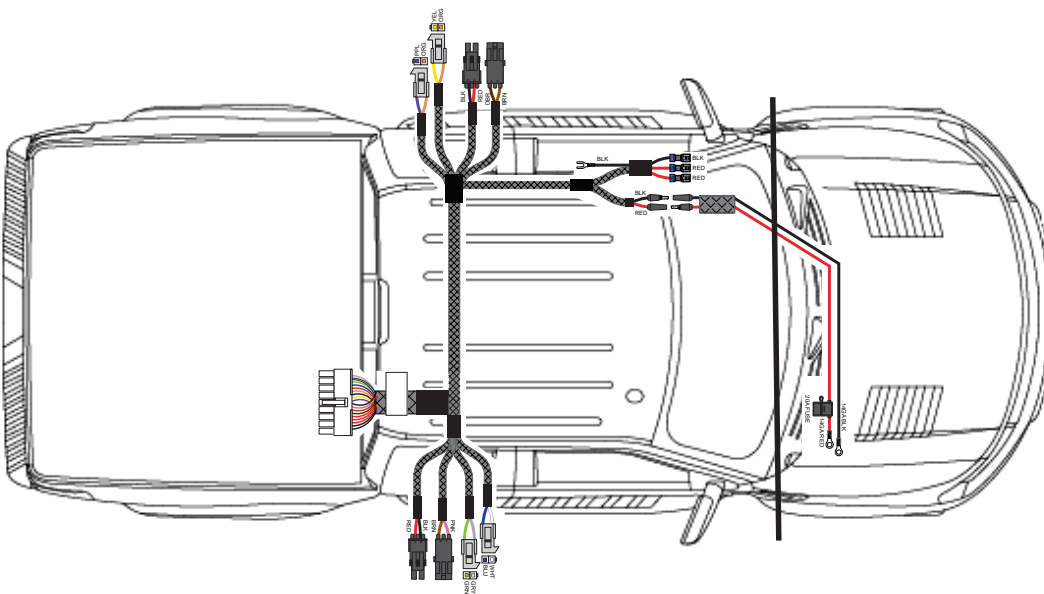
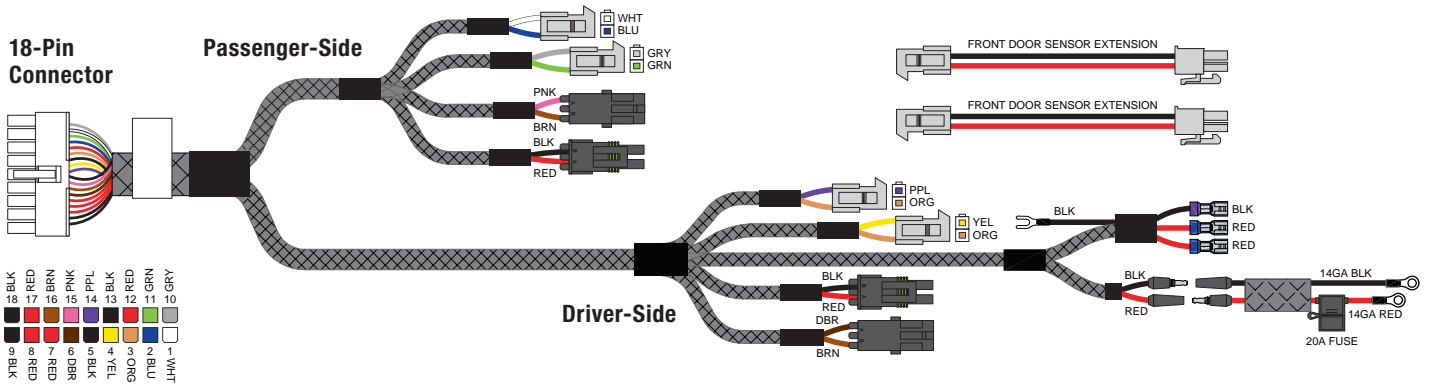

### Step 11

On the driver side, take the power wire and sensor wire (orange / yellow) and route it to the front of the vehicle underneath the carpet.

If there is no plug in the floor behind the driver seat, skip to step 12.

If there is a plug in the floor behind the driver seat continue this step.

Take the driver-side rear actuator (red / black) and the LED light (brown / tan) and route it through the floor plug behind the driver seat.

With the rear wires inserted through the floor hole, cut a slot in the floor plug and re-insert it into the hole.

Skip to step 13.

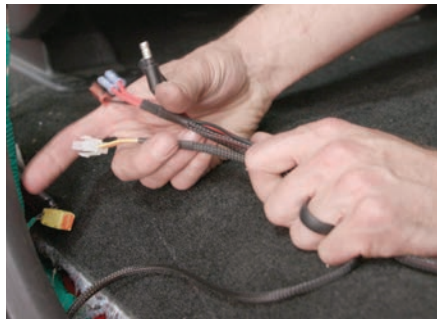

### Step 12

If there is no plug in the floor behind the driver seat, locate a position close to the rear bracket and drill a 1" hole through the floor of the vehicle. **WARNING:** Make sure there are no obstructions in the drilling location.

Once the hole is drilled, take the driver-side rear actuator (red / black) and the LED light (brown / tan) and route it down through the floor. Secure in place with the provided rubber grommet. Continue to step 13.



### Step 13

On the passenger side, take the sensor wire (gray / green) and route it to the front of the vehicle underneath the carpet.

Take the passenger-side rear actuator (red / black) and the LED light (pink / tan) and route it through the floor plug behind the passenger seat. If there is no plug in the floor behind the passenger seat, repeat step 12 on the passenger-side of the vehicle.



### Step 14

Plug the door sensor into the wiring harness and route it up the door frame, under the carpet.

**Note:** Depending on the vehicle, you may need to use the supplied sensor harness extensions for the two front door sensors.

Once the harness and sensor are routed to the desired location, wipe the sensor and door with the provided alcohol wipe. Place two pieces of 1/2" x 1/2" double-sided tape on the sensor and attach the sensor to the vehicle.

Repeat this process for the other three doors.

**DISCLAIMER:** Use of this switch requires manual operation of the boards. Failure to retract the boards when operating the vehicle could result in damage to the boards or vehicle.

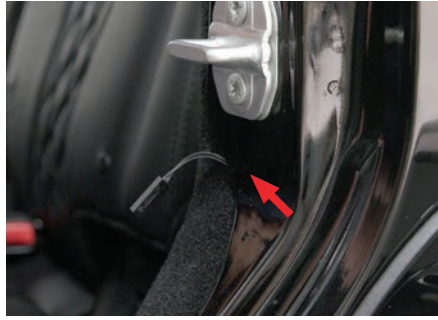

### Step 15

Using the 3/4" x 3/4" double-sided tape, place the magnet on the door so it lines up with the sensor. Repeat this for the other three doors.

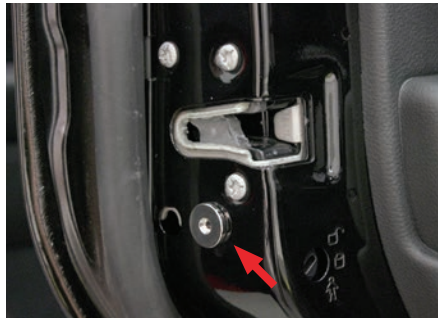



### Step 16

On the driver side, plug the rear actuator (red / black) into the running board and pull the extra wire back into the vehicle.

Plug the LED light wire (brown / tan) into the LED light and secure it to the mounting bracket tab with the supplied jam nut.

Once all the wiring is installed, cover the wires with slit loom for extra protection.

Repeat for the passenger side of the vehicle. Refer to step 12 for wiring call out.



### Step 17

Locate a spot to install the power switch. Drill a hole in the panel with a 3/4" drill bit and wire into place.

**WARNING:** Confirm there are no wires behind the panel prior to drilling.

**Important:** Be sure to plug the blue female wires into the silver male ends and the red female wire into the bronze male end.





### Step 18

Once all wiring is installed, plug in the circuit board and place it underneath the carpet under the rear passenger seat.

Attach the two wiring harnesses and re-install the fuse removed in step 8.

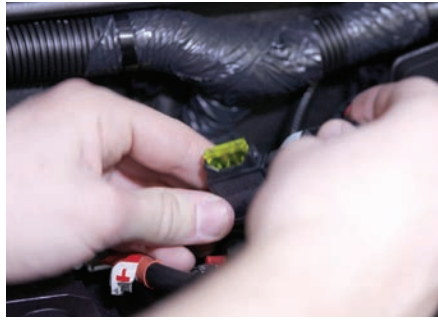

### Step 19

Congratulations on the installation of your new powered running boards.

With the running boards installed, periodic inspections should be performed to ensure all mounting hardware remains tight.

To protect your investment, see the 'Notes and Maintenance' section on the first page of this instruction manual.



# TROUBLESHOOTING & REGISTRATION

## Troubleshooting

<b>I just installed my steps and they are not coming down when I open the door.</b>	Double check the connections. Check the fuse to make sure it is plugged in. Is the on / off switch getting power? Is the circuit board plugged in? Are the door sensors plugged in?
<b>My switch is getting power, but the light stays on in both positions.</b>	The light is only supposed to be on when the system is turned on. If it is lit in both positions simply switch the red wires on the back. Will this kill my battery with the light constantly lit? This will not kill your battery unless you leave it lit for a month with no use.
<b>Everything is plugged in and the switch is turning on and off, but the steps still won't deploy.</b>	Two things may be causing this issue:  Check the motor first. Simply unplug it from the wiring harness and apply external 12V power to the leads. One position will make them deploy. Switch the leads again to make them retract. If this works, plug the motor back into the harness. We test each and every motor that leaves our factory by hand along with assembling your step slider by hand. These may fail, but it is extremely rare after we send them after having tested them. If you test the motor and all you hear is a clicking sound but nothing happens, there is likely internal damage.  Check the sensors. Unplug both of them from the wiring harness, and plug one back in. Manually test your sensors by putting a magnet really close (but not touching) to the sensor. Does it make the step retract? When the magnet is away, the step should deploy. If the steps deploy right after installation, more than likely your magnets just need to be aligned. Do this one by one with each sensor by the method above. Install one sensor, test, align the magnet on the door, test, and then mark the position of the magnet so if for some reason they do move out of place you can easily realign them. The sensors should have a label with MP###802 or MP###902.
<b>I tested the motor, and it works. I checked the sensors individually, and the system still won't work. The steps don't deploy unless I do it manually with 12V power.</b>	In rare circumstances, the circuit board that runs the system may be faulty.
<b>I opened my door a bunch of times and the system just shut off. What happened?</b>	Our systems have built-in protection against quick cycling like this to prevent damage. Simply turn your on / off switch to off, wait 5 seconds, and then turn it on again. This will reset the system and allow it to work normally again.
<b>My running boards are making squeaking and / or rubbing sounds.</b>	Apply a dry, graphite powder lubricant on each pivot point. 