



# Installation Instructions

## 3025170

### Level of Difficulty

Moderate

This is the first of two manuals required to complete this installation. The second manual is included with your side bars / running boards.

### Parts List

2	Mounting bracket, front
2	Mounting bracket, middle
2	Mounting bracket, rear
6	T-rails
12	Hex bolt, 1/4"
12	Flat washer, 1/4"
12	Nylock nut, 1/4"
12	Nylock nut, 5/16"
6	Hex bolt, M8 x 24.5mm
18	Flat washer, M8
6	Lock washer, M8
4	Door sensor
4	Magnet
2	Alcohol wipe
1	Power switch
1	Circuit board
1	Anti-seize
1	Wire loom
1	Wiring harness, two-piece
2	LED light
2	LED light bracket
4	Double-sided foam tape, 3/4" x 3/4"
8	Double-sided foam tape, 1/2" x 1/2"

\*Running boards sold separately

### Tools Required

Ratchet	Drill
Socket set	Drill bit set
Zip ties	Level

### ⚠ WARNING

Improper electrical installation may result in personal injury. Unless you are familiar with the installation and handling of electrical systems, have this step performed by someone who has that familiarity.

### Product Photo



### Notes and Maintenance

Before you begin installation, read all instructions thoroughly.

Proper tools will improve the quality of installation and reduce the time required.

No maintenance required on waterproof harness or water-resistant motors. If mud or dirt is built up on the steps, simply spray them off and let them air dry.

Mild automotive detergent may be used to clean the product. Do not use dish detergent, abrasive cleaners, abrasive pads, wire brushes or other similar products that may damage the finish.

Periodic inspection of all wires and connections should be performed to ensure there is no visible damage or loose connections.

Refer to the table below when securing hardware during the installation process to help prevent damage to the product or vehicle.

### Torque Specifications

Metric			SAE		
	M6 bolt	3 ft-lbs.		1/4" bolt	3 ft-lbs.
M8 bolt	7 ft-lbs.	5/16" bolt	7 ft-lbs.		
M10 bolt	16 ft-lbs.	3/8" bolt	16 ft-lbs.		
M12 bolt	28 ft-lbs.	7/16" bolt	20 ft-lbs.		
--	--	1/2" bolt	28 ft-lbs.		

Use above torque setting unless otherwise noted

### Step 1

Starting on the passenger side, locate the three mounting locations underneath the vehicle.

**Note:** Each bracket is specific to a mounting location. Refer to page 1 product image for correct locations.

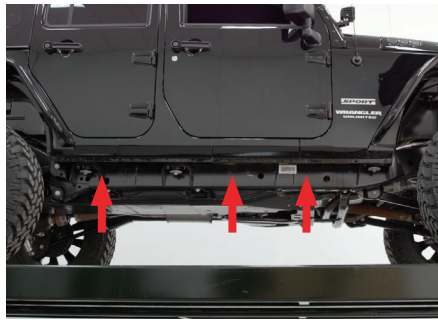

### Step 2

Starting at the front passenger-side mounting location, attach the mounting bracket through the two holes on the vehicle rocker panel using two 1/4" flat washers and 1/4" nylock nuts.

Once the bracket is attached, mount one M8 bolt, M8 lock washer and M8 flat washer with anti-seize.

Snug the hardware, but do not fully tighten.

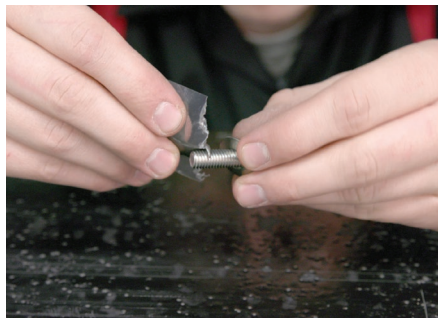
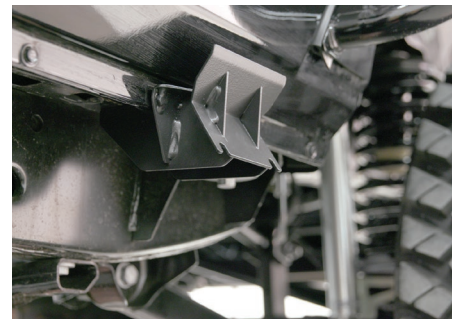

### Step 3

Repeat step 2 for the middle and rear brackets.

Repeat this entire process on the passenger side of the vehicle.

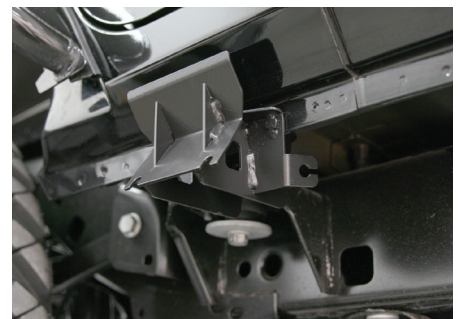

#### Step 4

Remove the fuse from the wiring harness before installing.

Once the fuse is removed, take that section of the wiring harness and attach it to the battery. Route the opposite end of the harness through the firewall into the cab of the vehicle.

Zip-tie the wiring harness in place once it is in the desired location.

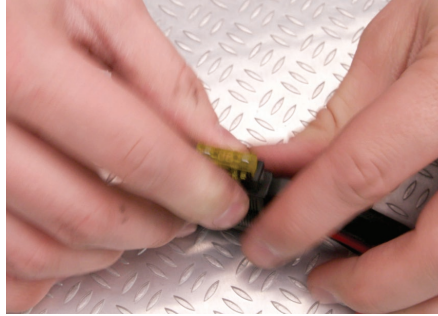
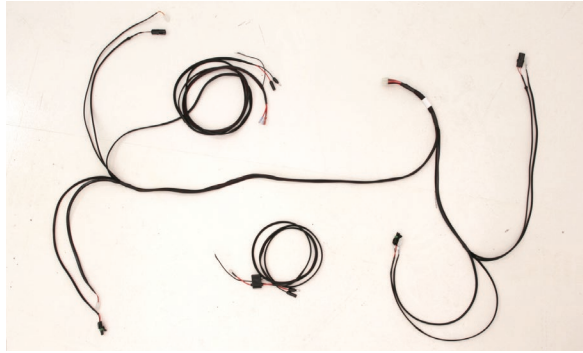

#### Step 5

Remove the fasteners securing the front and rear door trim panels on both sides of the vehicle. There are five clips on each side of the vehicle securing the trim panels, three for the front and two for the rear.

**Note:** It may be easier to move the seats all the way back when removing the front trim panel and all the way forward when removing the rear trim panel.



## Step 6

Once the trim panels are removed, take the second section of wiring harness and route it under the carpet, through the vehicle, from the passenger-side rear to the desired location.

Refer to the diagrams below.



## Wiring Locations

	Driver	Passenger
Door sensor, rear	Purple / Orange	White / Blue
Door sensor, front	Yellow / Orange	Grey / Green
LED light	Brown / Dark brown	Pink / Brown
Actuator	Black / Red	Black / Red

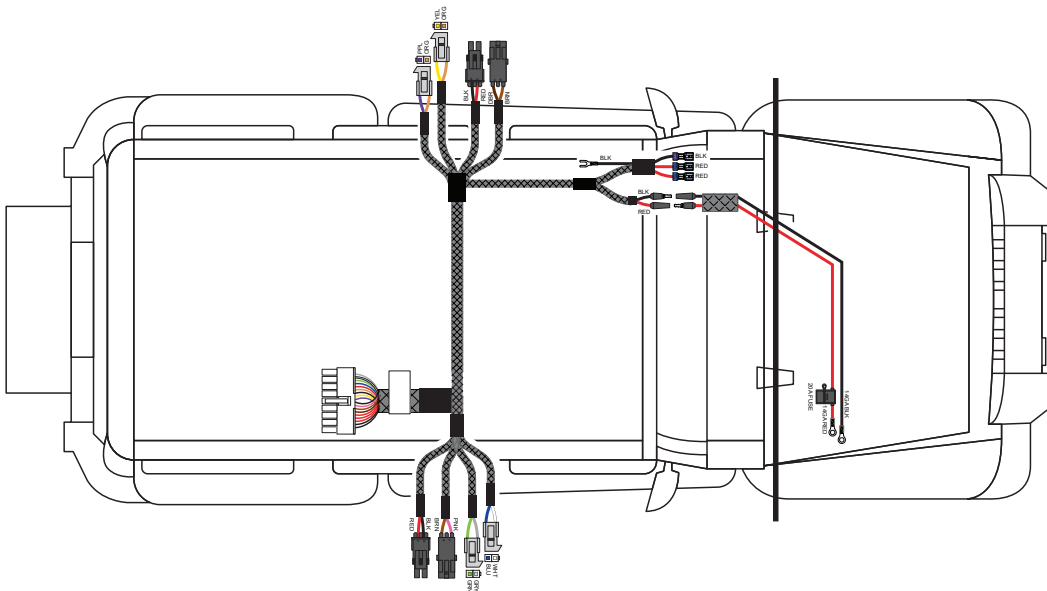
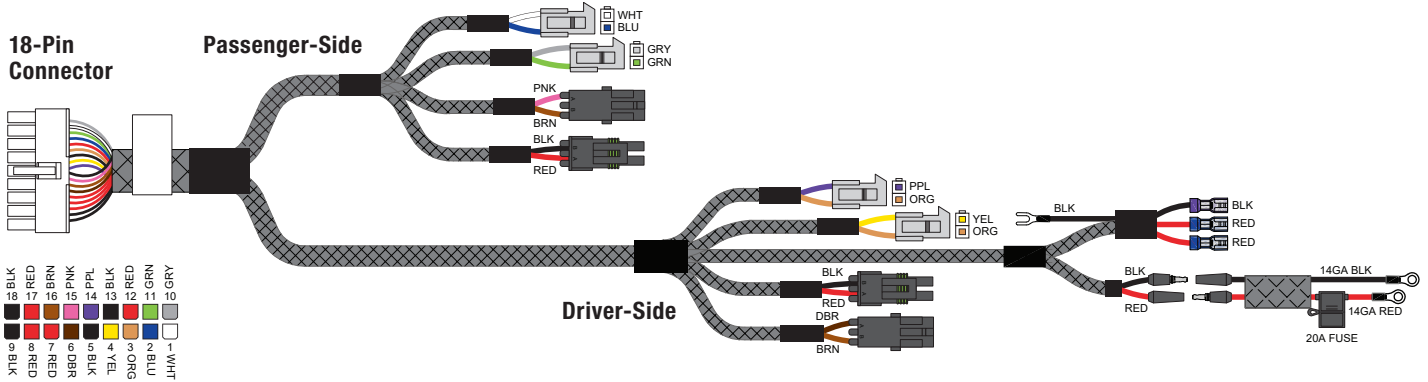

### Step 7

On the driver side, take the power wire and sensor wire (orange / yellow) and route it to the front of the vehicle underneath the carpet.

Take the driver-side rear actuator (red / black) and the LED light (brown / tan) and route it through the floor plug behind the driver seat.



### Step 8

On the passenger side, take the sensor wire (gray / green) and route it to the front of the vehicle underneath the carpet.

Take the passenger-side rear actuator (red / black) and the LED light (pink / tan) and route it through the floor plug behind the driver seat.



### Step 9

With the rear wires inserted through the floor hole, cut a slot in the floor plug and re-insert it into the hole.



### Step 10

Plug the door sensor into the wiring harness and route it up the door frame, under the carpet.

**Note:** If installing a door delete switch, refer to part #3020000-INS at this time.

Once the harness and sensor are routed to the desired location, wipe the sensor and door with the provided alcohol wipe. Place two pieces of 1/2" x 1/2" double-sided tape on the sensor and attach the sensor to the vehicle.

Repeat this process for the other three doors.

**DISCLAIMER:** Use of this switch requires manual operation of the boards. Failure to retract the boards when operating the vehicle could result in damage to the boards or vehicle.

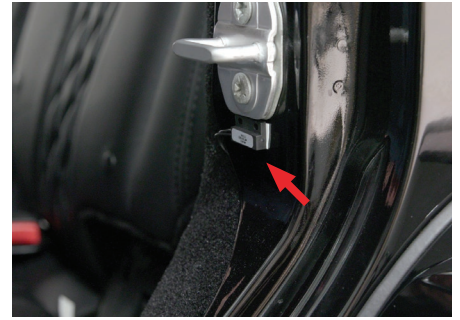
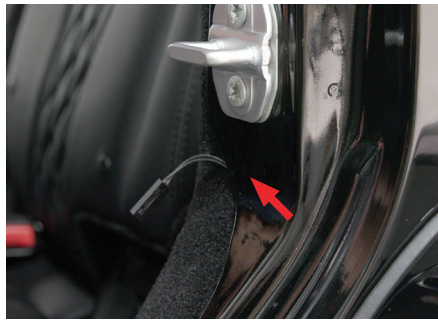

### Step 11

Using the 3/4" x 3/4" double-sided tape, place the magnet on the door so it lines up with the sensor. Repeat this for the other three doors.

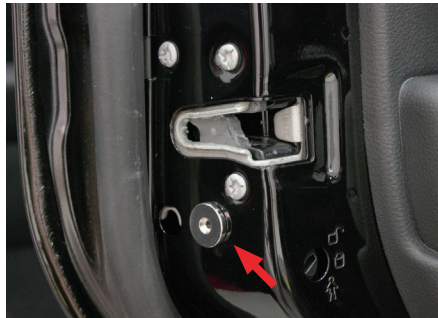

### Step 12

Locate a spot to install the power switch. Drill a hole in the panel with a 3/4" drill bit and wire into place.

**WARNING:** Confirm there are no wires behind the panel prior to drilling.

**IMPORTANT:** Be sure to plug the blue female wires into the silver male ends and the red female wire into the bronze male end.



### Step 13

Once all wiring is installed, plug in the circuit board and place it underneath the carpet under the rear passenger seat.

**Note:** To complete the installation, refer to the manual included with your side bars / running boards.



# TROUBLESHOOTING

Troubleshooting	
<p><b>I just installed my steps and they are not coming down when I open the door.</b></p>	<p>Double check the connections. Check the fuse to make sure it is plugged in. Is the on / off switch getting power? Is the circuit board plugged in? Are the door sensors plugged in?</p>
<p><b>My switch is getting power, but the light stays on in both positions.</b></p>	<p>The light is only supposed to be on when the system is turned on. If it is lit in both positions simply switch the red wires on the back. Will this kill my battery with the light constantly lit? This will not kill your battery unless you leave it lit for a month with no use.</p>
<p><b>Everything is plugged in and the switch is turning on and off, but the steps still won't deploy.</b></p>	<p>Two things may be causing this issue:</p> <p>Check the motor first. Simply unplug it from the wiring harness and apply external 12V power to the leads. One position will make them deploy. Switch the leads again to make them retract. If this works, plug the motor back into the harness. We test each and every motor that leaves our factory by hand along with assembling your step slider by hand. These may fail, but it is extremely rare after we send them after having tested them. If you test the motor and all you hear is a clicking sound but nothing happens, there is likely internal damage.</p> <p>Check the sensors. Unplug both of them from the wiring harness, and plug one back in. Manually test your sensors by putting a magnet really close (but not touching) to the sensor. Does it make the step retract? When the magnet is away, the step should deploy. If the steps deploy right after installation, more than likely your magnets just need to be aligned. Do this one by one with each sensor by the method above. Install one sensor, test, align the magnet on the door, test, and then mark the position of the magnet so if for some reason they do move out of place you can easily realign them. The sensors should have a label with MP###802 or MP###902.</p>
<p><b>I tested the motor, and it works. I checked the sensors individually, and the system still won't work. The steps don't deploy unless I do it manually with 12V power.</b></p>	<p>In rare circumstances, the circuit board that runs the system may be faulty.</p>
<p><b>I opened my door a bunch of times and the system just shut off. What happened?</b></p>	<p>Our systems have built-in protection against quick cycling like this to prevent damage. Simply turn your on / off switch to off, wait 5 seconds, and then turn it on again. This will reset the system and allow it to work normally again.</p>
<p><b>Everything is working now. But I want to take my doors off and have the steps still work.</b></p>	<p>We sell a door delete kit you can replace those sensors with. Part# 3020000 comes with everything you need for two doors. If you want to install a delete kit on the rear doors as well, you will need to purchase two kits.</p>
<p><b>My running boards are making squeaking and / or rubbing sounds.</b></p>	<p>Apply a dry, graphite powder lubricant on each pivot point.</p> 