

INSTALLATION MANUAL

2165002

Level of Difficulty

Easy

Parts List

1	Bull bar
1	Driver / left mounting bracket
1	Passenger / right mounting bracket
1	Driver / left side brace bracket
1	Passenger / right side brace bracket
1	Driver / left side adapter bracket
1	Passenger / right side adapter bracket
2	Bolt plate, M12
2	Hex bolt, M12
6	Flat washer, M12
4	Lock washer, M12
4	Hex nut, M12
4	Hex bolt, M10
4	Nylock nut, M10
8	Flat washer, M10
4	Hex nut, M8
4	Flat washer, M8
4	Nylock nut, M8
2	Hex bolt, M14
2	Lock washer, M14
2	Flat washer, M14
1	LED wiring harness*

* Wiring harness only included with LED equipped models

Tools Required

Ratchet	Box wrench set
Socket set	Level
Socket extension	--

Torque Specifications

Metric	M6 bolt	3 ft-lbs.
	M8 bolt	7 ft-lbs.
	M10 bolt	16 ft-lbs.
	M12 bolt	28 ft-lbs.
SAE	1/4" bolt	3 ft-lbs.
	5/16" bolt	7 ft-lbs.
	3/8" bolt	16 ft-lbs.
	7/16" bolt	20 ft-lbs.
	1/2" bolt	28 ft-lbs.

Use above torque setting unless otherwise noted

Product Photo

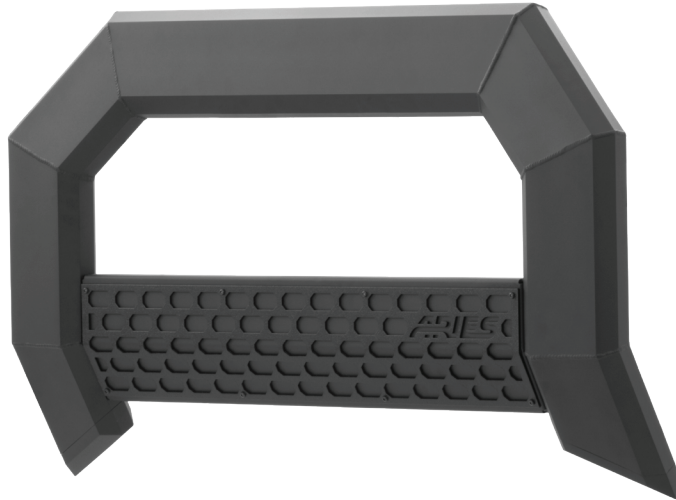

NOTICE

Before you begin installation, read all instructions thoroughly.

Proper tools will improve the quality of installation and reduce the time required.

To help prevent damage to the product or vehicle, refer to the specified torque specifications when securing hardware during the installation process.

Maintenance

To protect the product, wax after installing. Regular waxing is recommended to add a protective layer over the finish. Do not use any type of polish or wax that may contain abrasives that could damage the finish.

For polished, gloss and other smooth finishes, polish may be used to clear small scratches and scuffs on the finish.

Mild automotive detergent may be used to clean the product. Do not use dish detergent, abrasive cleaners, abrasive pads, wire brushes or other similar products that may damage the finish.

Step 1

For vehicles with tow hooks, remove the tow hooks from the vehicle by removing the two bolts securing them to the frame. The rear bolt will be reused.

For vehicles without tow hooks, remove the plastic covers from the tow hook openings by loosening the two nuts on top and removing the star washers from the bottom pegs. The covers will pull out through the front.



Step 2

For vehicles with tow hooks, reinstall the rear bolt through the rear slot. Secure the forward position using the provided M14 hex bolts, lock washers and flat washers.

For vehicles without tow hooks, loosen the rear bolt just enough to allow the bracket to slide between the bolt and the tube spacer that is welded to the frame.

Snug the hardware, but do not fully tighten.



Step 3

Place a bolt plate through the rear of the opening, as shown.

Locate the passenger-side brace bracket and place it on the opposite side of the bolt plate, putting the bolt through the slot of the small tab of the brace bracket. Secure the brace bracket to the bolt plate using an M12 flat washer, lock washer and hex nut.

Snug the hardware, but do not fully tighten.

Repeat this step on the driver side.



Step 4

Secure the brace bracket to the tow hook bracket using an M12 hex bolt, two flat washers, a lock washer and hex nut.

Snug the hardware, but do not fully tighten.

Repeat this step on the driver side.



Step 5

To attach the bull bar mounting brackets, lay the bull bar on a flat surface. Insert two M8 hex bolts into the inner rail slot.

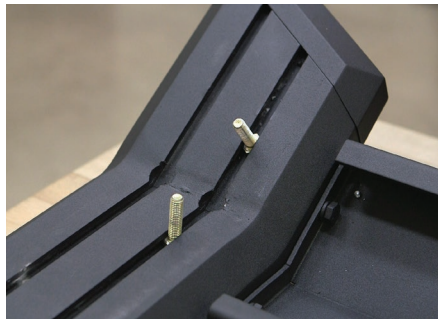

Step 6

Place the passenger-side bracket over the bolts and secure the bracket to the bull bar using two M8 flat washers and M8 nylock nuts.

Snug the hardware, but do not fully tighten.

Repeat this step on the driver side.



Step 7

With assistance, lift the bull bar into place and align the mounting tabs on the outside of the mounting brackets.

Insert an M10 hex bolt with a flat washer on the outside of the bracket and an M10 flat washer and nylock nut on the inside for each slot.

Snug the hardware, but do not fully tighten.



Step 8

Level and adjust the bull bar into the desired position. Tighten all hardware to the recommended torque specifications listed in the table on page one.

If your bull bar is not equipped with lights, skip to step 11.

If your bull bar is equipped with lights, complete steps 9 - 10.

Note: If the LED lights are being used with a 24V system, the 12V relay will need to be replaced with a 24V unit.



Step 9

Disconnect the supplied switch from the wire harness and install in desired location.

With the switch installed, route the wire harness to the LED lights and the switch.

Reconnect the blue, red and black spade connectors to the switch, as shown.

Note: The black wire connects to the gold switch terminal.

Plug the male connector on the wire harness into the female connector attached to the LED lights.

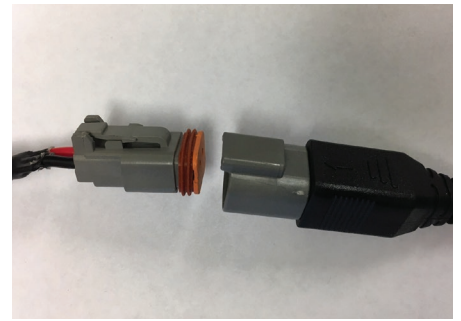
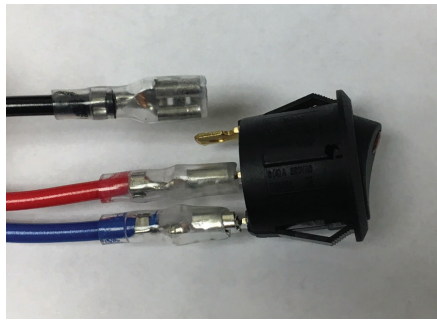

Step 10

Connect the red fused wire with the ring terminal to the positive battery post.

Connect the black wire ring terminal to the negative battery post or other suitable vehicle grounding point.

Mount the supplied relay to the vehicle and secure all wires with zip ties away from any moving parts to avoid damage.

Test the lights to ensure proper function.

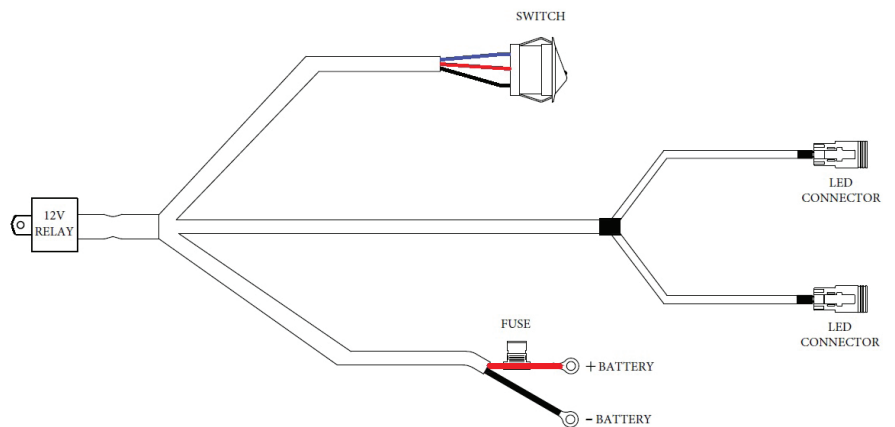

Step 11

Congratulations on the installation of your new ARIES AdvantEDGE™ bull bar.

With the bull bar installed, periodic inspections should be performed to ensure all mounting hardware remains tight.

To protect your investment, see the 'Notes and Maintenance' section on the first page of this instruction manual.

