



INSTALLATION INSTRUCTIONS

2007-12 JEEP JK 3RD BRAKE LIGHT BRACKET

Part 25630TBL (works with 25630)

PARTS LIST:

Qty	Description	Qty	Description
1	3 rd Light bracket	8	8mm Lock Washer
8	8mm x 25mm Hex Bolt	8	8mm Hex Nuts
16	8mm ID x 30mm OD Flat Washer		

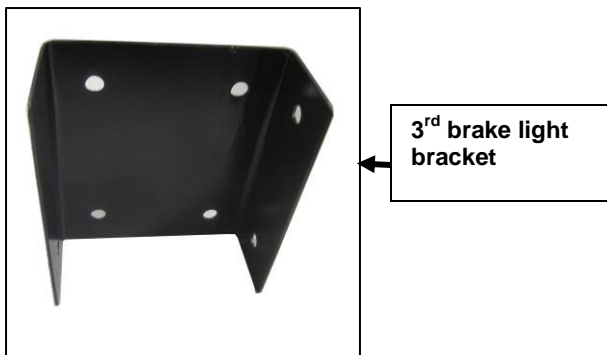

PROCEDURE:

- 1. REMOVE CONTENTS FROM BOX. VERIFY ALL PARTS ARE PRESENT. READ INSTRUCTIONS CAREFULLY BEFORE STARTING INSTALLATION.**
- 2.** Start by removing the tire and then the factory tire carrier by open the back door, locate the plastic louvered cover (**Fig 1**) pry the cover's corners to remove this cover, once removed locate the plug for the factory 3rd brake light and unplug it (**Fig 2**), push the wire and the rubber grommet out so that the wire is completely removed from the door, (**Fig 3**) place the new rubber plug into hole sealing it.
- 3.** Once wire is removed from door, remove the bolts holding the factory carrier to the rear door (**Fig 4**) place the carrier on a flat work space as you will need to measure from the bottom line as seen in (**Fig 5**) 3 1/2" up mark with a line (mark on both sides right side left side, so your line is level) once marked you will need to cut with either a cut off wheel on a grinder or a hack saw. Slowly making your cut to keep the cutline true.
- 4.** Once carrier is separated select the new 3rd brake light bracket and place it into place coupling the rear of carrier, the edge of the bracket should sit flush with the edge of the carrier as seen in (**Fig 6,7&8**) taking note of the alignment, mark holes through the bracket to the carrier for drilling the (4) holes on the bottom (use a 3/8" size drill bit) with these holes drilled it is easier to attach (2) of the 8mm hex bolts (4) 8mm washers & (2) 8mm hex nuts snug but do not tighten for the measuring of the top holes to be drilled.

5. Once lower part of bracket is attached measure from the lower cut edge up to the top cut edge (distance apart) 3" as seen in **(Fig 9)** make sure top portion is aligned, once satisfied with position & alignment mark holes through bracket for drilling (use a 3/8" size drill bit) to drill holes.
6. Once holes are drilled remove the previously install 8mm hardware (bottom) as we recommend you spray paint the edge of the carrier pieces you cut earlier (these parts are aluminum and will not rust but will be more pleasing to the eye if painted) once paint is dry attach the bottom bracket with (4) 8mm hex bolts, (8) 8mm flat washers, (4) 8mm lock washers and (4) 8mm Hex nuts, as seen in **(Fig 10)** Snug but do not tighten.
7. Attach the Upper portion of bracket to the lower lip of brake light with (4) 8mm hex bolts, (8) 8mm flat washers, (4) 8mm lock washers and (4) 8mm Hex nuts, as seen in **(Fig 10)** Snug but do not tighten.
8. Next reattach the tire carrier to the rear door with the factory (8) bolts; once all bolts are in place tighten the factory bolts. With the carrier attached feed the brake light cable back through the door pushing in the rubber plug and plug the wire harness back in, once done replace the plastic panel back onto the doors inner panel, as seen in **(Fig 3, 2 & 1)**.
9. With the door closed align the brake light assemblies so it holds the light strait up once satisfied tighten all hardware. reattach the tire as seen in **(Fig11)**

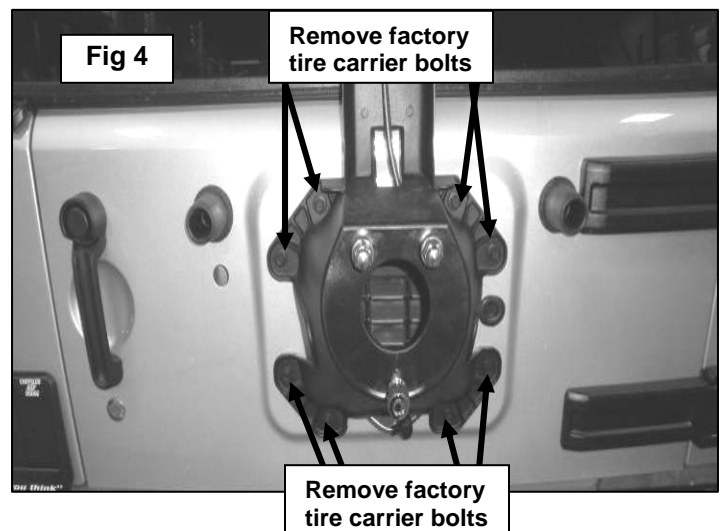
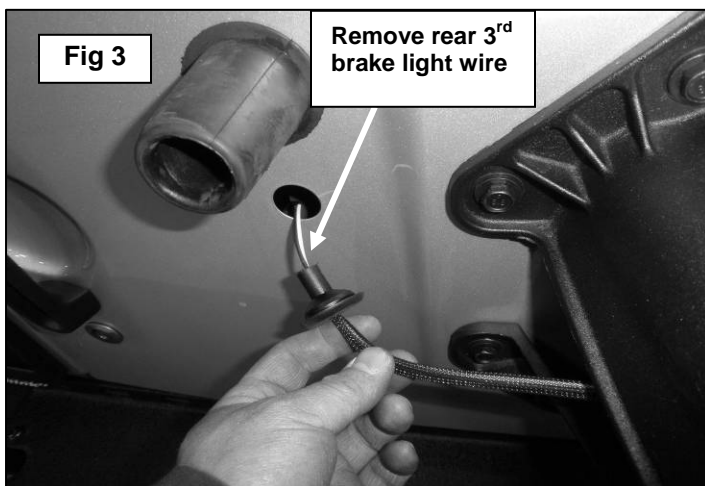
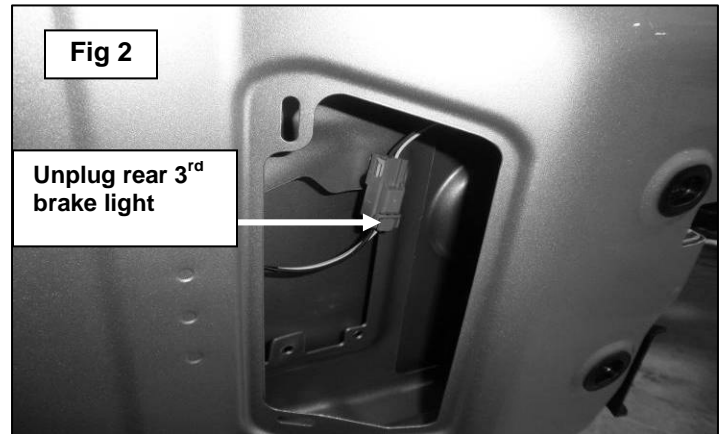
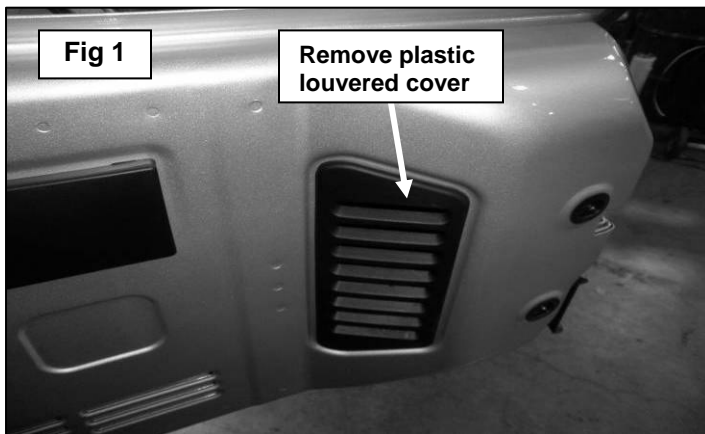

Fig 5

**Cutting
Measurements**

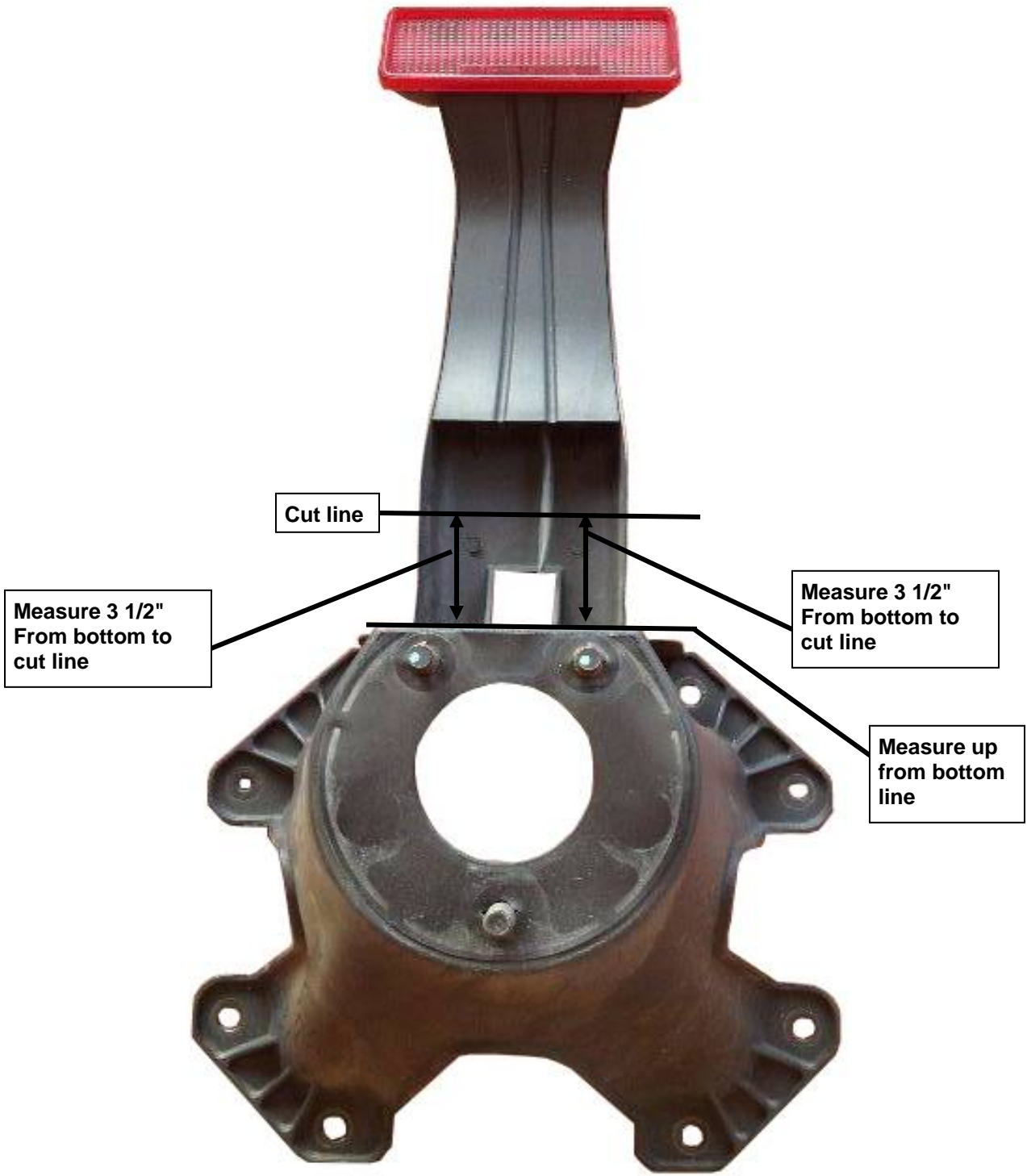

Fig 6

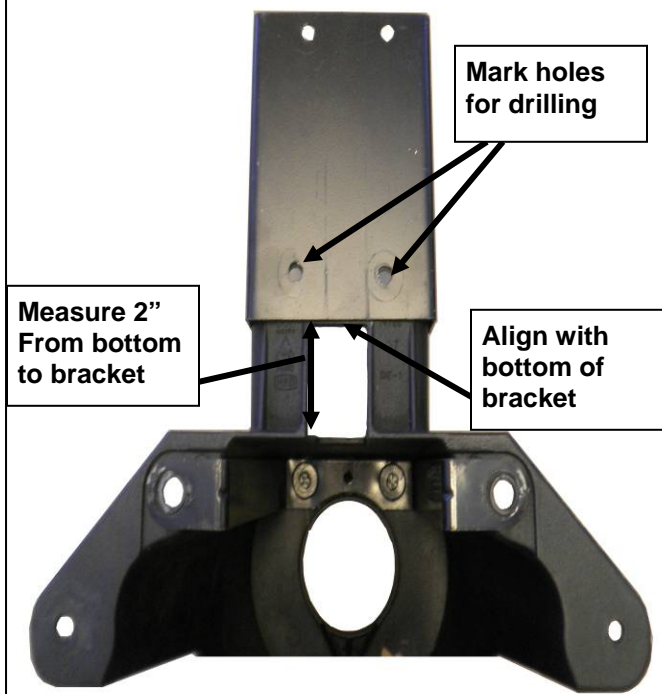

Fig 7



Fig 8

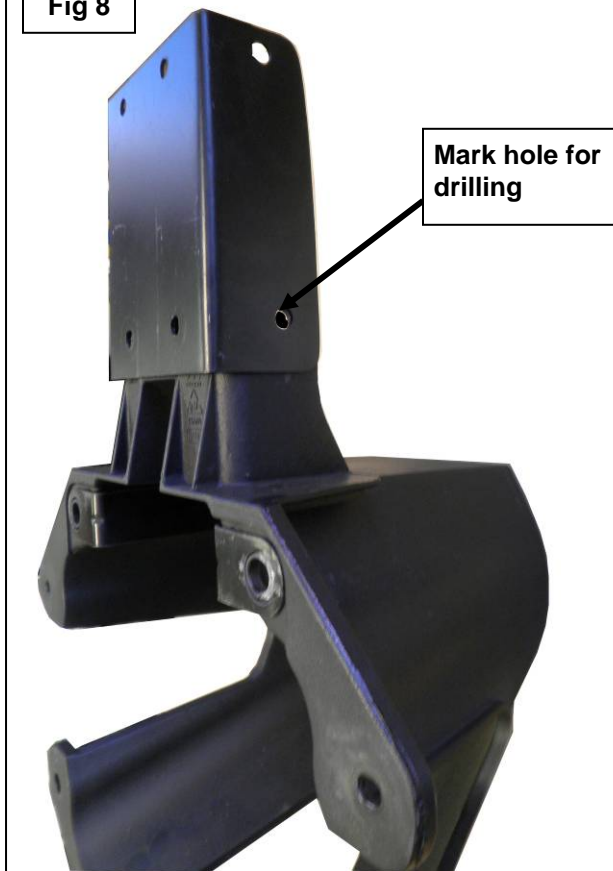

Fig 9

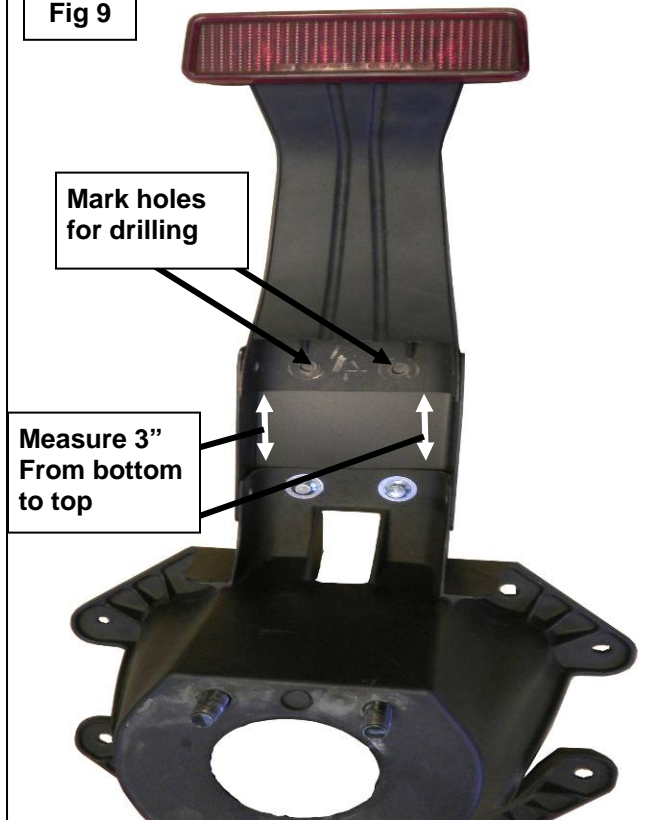

Fig 10

