

**DATE:**  
June 2012

**DESCRIPTION:**  
Skid Plate System

**APPLICATION:**  
Toyota Prado 120/150, 4Runner &  
FJ Cruiser

**PART NO. :**  
5421100 - Prado 120/150 & FJ Cruiser  
5421110 - Prado 150  
5421100 - 2010-12 4Runner (w/o Kinetic)  
5421110 - 2010-12 4Runner (with Kinetic)

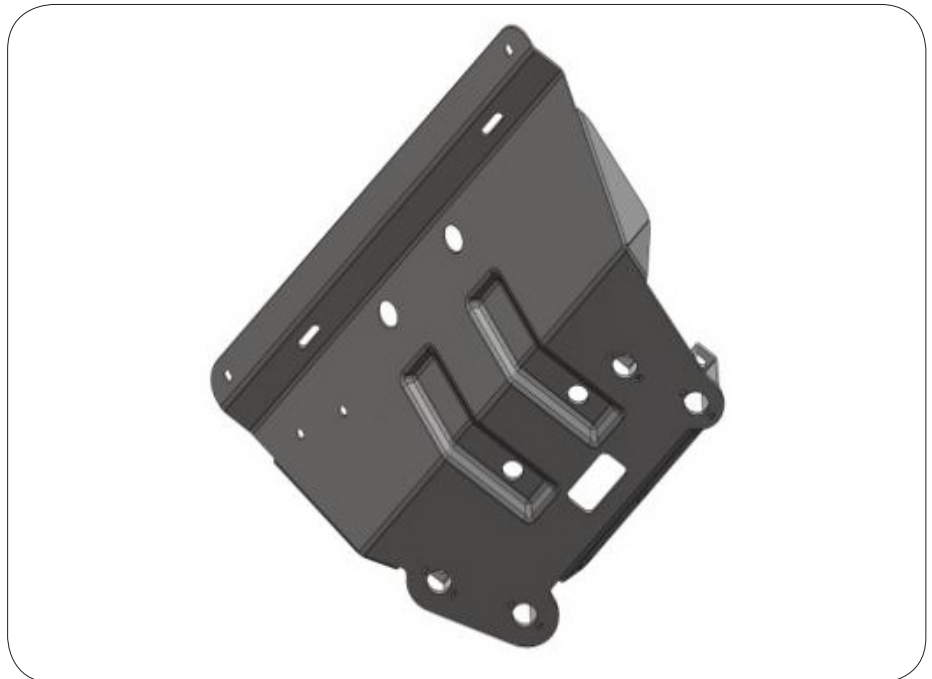

# PRODUCT SPECIFICATION

## DESIGN & DEVELOPMENT:

The first skid plate panels system specifically designed for SUVs, these panels feature the same construction as the current range of panels, ie. pressed and folded 3mm steel. Due to the Prado 120/150, 4Runner and FJ Cruiser sharing the same chassis platform, the same skid plate design has been used for the four vehicles. However, a second kit has been built to suit the Prado 150 and 2010+ 4Runner with Kinetic suspension system as a slightly different lower 'bulge' is required in the front panel due to the positioning of the kinetic sway bar.

The transmission panel is common to both kits and also to petrol and diesel engine variants. It has a two position mounting bracket providing a lower mount for petrol engine vehicles where the exhaust sits lower than diesel models. The transmission panel is also tapered to the rear to clear chassis bracing that is unique to the Prado/FJ chassis design.

## PROTECTION & STYLING CHARACTERISTICS:

Developed with extensive field testing, ARB skid plates give protection to vital underbody components with vehicle specific models protecting steering, engine oil panel, transmission and transfer case where applicable. Panels are easily removed for vehicle servicing and where practical, include access to oil panel drain plugs. Each panel has recessed mounting bolts in vulnerable areas to ensure ease of removal even if the panels become damaged from severe off road service.

ARB Skid Plate are fully compatible with all ARB products such as Bull Bars, Side Rail & Steps, Airlocker and OME.

## FEATURES:

- Designed to protect vital underbody components including steering, engine oil pan, transmission and transfer case (dependant on vehicle model).
- Vehicle specific design.
- Manufactured from pressed and folded 3mm laser cut steel.
- Securely bolted to the vehicle's chassis providing outstanding structural integrity.
- All steel components are zinc plated and powder coated in a silver textured finish.
- Easily removed for vehicle servicing.

## NOTE:

- While these skid plates have been engineered for strength and functionality, care and good judgment should be taken when traversing difficult off-road terrain to minimize damage to panels and vehicle.
- During servicing when panels are removed ensure fasteners are re-fitted to the correct torque values.
- Inspect panels visually on a regular basis. Dirt and foreign matter should be washed out to minimize build-up around hot components. **BE VERY CAREFUL** when removing foreign matter with hands while vehicle is hot or running. Replace any components as necessary. This service can be performed by your local authorized ARB distributor.

Following images:

1. Prado 120/150 & FJ Cruiser front panel (without Kinetic suspension).
2. Prado 150 front panel (with Kinetic suspension).
3. Transmission panel is common to both kits.

