

ARB FITTING INSTRUCTIONS

ARB WINCH / NON WINCH BULL BAR TO SUIT LANDROVER DISCOVERY 2003 ONWARD .

FITTING KIT No's :- 617 1793 [BULL BAR WINCH](#) (P/No 343 2120)

617 1794 BULL BAR NON WINCH (P/No 323 2120)

WARNING

FOR VEHICLES EQUIPPED WITH SRS AIRBAG

WHEN INSTALLED IN ACCORDANCE WITH THESE INSTRUCTIONS, THE FRONT PROTECTION BAR DOES NOT AFFECT OPERATION OF THE SRS AIRBAG.

TAKE NOTE OF THE FOLLOWING:

- **THIS PRODUCT MUST BE INSTALLED EXACTLY AS PER THESE INSTRUCTIONS USING ONLY THE HARDWARE SUPPLIED.**
- **DO NOT USE THIS PRODUCT FOR ANY VEHICLE MAKE OR MODEL, OTHER THAN THOSE SPECIFIED BY ARB.**
- **DO NOT REMOVE LABELS FROM THIS BULL BAR.**

THIS PRODUCT OR ITS FIXING MUST NOT BE MODIFIED IN ANY WAY.

USE	PART No	QTY	DESCRIPTION
IMPACT ABSORBER TO CHASSIS	375 6482 LH	1	IMPACT ABSORBER LH
	375 6482 RH	1	IMPACT ABSORBER RH
	615 1243	6	M10 x 130 mm BOLT
	458 1048	6	M10 SPRING WASHER
	458 1040	12	M10 FLAT WASHER
	615 1026	6	M10 NUT
	615 1081	2	7/16" x 4 1/2" BOLT
	458 1042	2	7/16" SPRING WASHER
	458 1041	4	7/16" FLAT WASHER
	615 1124	2	7/16" NUT
IMPACT ABSORBER TO BULL BAR	615 1045	8	M10 x 25 mm BOLT
	458 1048	8	M10 SPRING WASHER
	458 1040	8	M10 FLAT WASHER
CONTROL BOX BRACKET TO BULL BAR	375 6499	1	CONTROL BOX BRACKET
	615 1021	2	M8 x 20 mm BOLT
	458 1044	2	M8 FLAT WASHER
	615 1132	2	M8 FLANGE NUT
NUMBER PLATE TO WINCH BAR	375 1313	1	NUMBER PLATE BRACKET
	615 1017	4	M6 x 16 mm BOLT
	615 1046	4	M6 FLAT WASHER
	615 1128	4	M6 FLANGE NUT
NUMBER PLATE TO NON WINCH BAR	615 1017	2	M6 x 16 mm BOLT
	615 1046	2	M6 FLAT WASHER
	615 1128	2	M6 FLANGE NUT
PLASTIC GUARD TRIM TO BULL BAR WING	615 1180	4	M6 x 20 mm BOLT
	615 1046	4	M6 FLAT WASHER
	615 1128	4	M6 FLANGE NUT
LOCKING BOLT HARDWARE	615 1045	2	M10 x 25 mm BOLT
	458 1048	2	M10 SPRING WASHER
	458 1040	4	M10 FLAT WASHER
	615 1026	2	M10 NUT
MISC	6821151L&R	1	ARB INDICATOR KIT
	180 302	8	BLACK CABLE TIES
	615 1017	4	M6 x 16 mm BOLT (FOG LAMP TO BAR)
	615 1046	4	M6 FLAT WASHER (FOG LAMP TO BAR)
	615 1277	6	SCREW COVER (FOG LAMP)
	615 1308	10	SCREW SELF TAPING (TURN & FOG)
	682 1116	4	NYLON PLUG (TURN SIGNAL BRACKET)
	EG50	1	GROMMET
	584 8283	2	NYLON WASHER (FOG LAMP SPACER)
	682 1152	2	WIRING LOOM (TURN SIGNAL)
	615 1309	6	CAPTIVE NUT "U" TYPE - CLIP
	615 1315	4	CAGE NUT M6
	375 6563 L	1	BRACKET FOG LAMP LH
	375 6563 R	1	BRACKET FOG LAMP RH

TOOLS REQUIRED: -

METRIC SPANNER & SOCKET SET , 7/16 SPANNER & SOCKET , ELECTRIC DRILL , DRILL BITS , 10 mm x 180 mm **EXTRA LONG** DRILL BIT, SHARPE KNIFE AND A METRIC TAPE MEASURE .

ASSEMBLY SEQUENCE FOR ARB BULL BAR.

1.& 2.



1. To remove the bumper bar from the vehicle undo the 7 screws that hold the plastic guard liner to the bumper bar on each side.

Undo the four nuts that hold the bumper to the aluminum brackets and loosen the two nuts located on the inside out board face .

Disconnect the fog lamp harness from both lamps and with assistance pull the bumper bar forward enough to disconnect the head lamp washers .

2. Remove the aluminum chassis extension brackets from both sides . Remove the tubular cross brace and the recovery bracket , both are refitted at a later stage.

Undo the 5 screws that hold the plastic air shield in place and with a small flat blade screw driver remove the two yellow plugs from the under side of the chassis rails .

3.&4.



3. Fit the new impact absorbers to both the LH & RH chassis rails . **Note the profiled edge faces outward** Using the 7/16 hardware supplied , bolt the RH impact absorber into position .

At this stage only the two horizontal bolts are fitted , repeat this on the LH side using the M10 hardware supplied (bolts are longer on LHS to fit recovery bracket) .

4. Once the impact absorbers are sitting horizontal and at the same height tighten both bolts . One of the holes in the impact absorber bottom bracket should line up with a square hole in the chassis .

Before drilling the vertical pinning bolts measure the distance between the two out side edges of the impact absorber – making sure the measurement is no larger than 809 mm (loosen bolts and adjust if necessary) .

5.& 6 .



5. When drilling the vertical pinning bolt **THE DRILL MUST BE VERTICAL IN BOTH DIRECTIONS** failure to do so will result in damage to the radiator mounting system .
Drill out both holes and assemble using the long M10 bolts and hardware supplied .

From the out board side of the chassis insert the chassis packers between the under side of the chassis and the impact absorber with the finger tab facing downward .

Repeat this on the LHS .

6.

The plastic air shield needs to be trimmed before being replaced , cut the holes (located on the edge tabs) into an open ended slot .

Place the shield back into its original position and screw across the back edge in 3 locations .

The edge tabs are now pushed in on top of the packer , the tabs are retained when the vertical bolts are done up and sandwiched between the chassis and the chassis spacer .

Re – confirm the measurement between the impact absorbers to ensure the bull bar will fit onto the vehicle and tighten all of the vertical bolts .

7.



7. **Remove the horizontal bolts only** , as previously described in **step 3**.

Re – assemble but this time the tubular cross brace and the original recovery point are attached .

Note the recovery bracket is located to the left hand chassis rail, and uses the longer metric M10 bolts .

8.



8. Placing the original bumper bar face down on a blanket remove all of the screws that hold the painted outer section to the main bumper .Using pliers remove the clip that holds the washer nozzle in the bumper and take out the nozzle (both sides) .These are re-fitted into the bull bar once the fog lamp and turn signal are installed .

Using a small flat bladed screw driver dis-engage the locking tabs on both sides and remove the cover , this will enable the fog lamp to be un-screwed in three places and removed .

9.

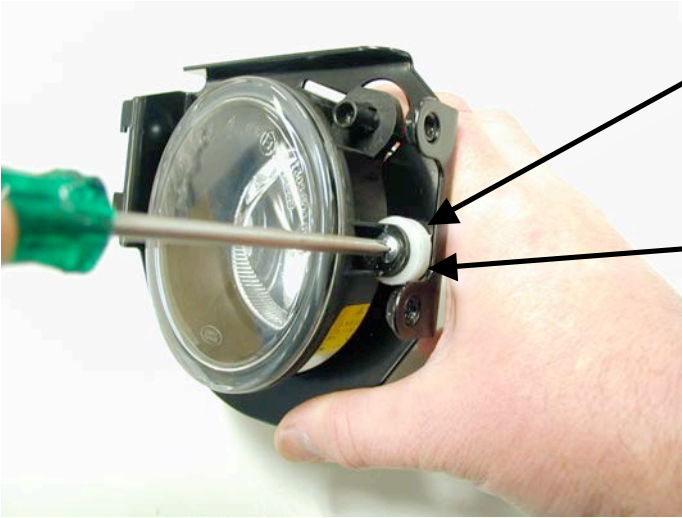

Fit the "u" nuts to the fog lamp bracket , the nylon washer fits between the bracket and the lamp mounting foot (located on the adjustment side) fit the fog lamp with the screws provided . Fit the screw covers over the exposed end of the screws in 3 places to each bracket.

Fit the M6 cage nuts into the large square holes in the edge flange of the fog lamp bracket . From the inside of the bracket , Squeeze the two legs of the cage nut together and fit to the hole . **NOTE :- The body of the nut is closest to the fog lamp .**

The Right hand fog lamp is shown .

Insert the nylon plugs into the square holes in the turn signal aperture , located on the inside face of the bull bar . From the rear , screw the turn signal assembly to the bracket on the bull bar , with the clear portion of the lens to the outboard edge .

Re-fit the washer nozzle both sides once the fog lamp & turn signal are fitted . The washer retaining clip may need to be flattened slightly to fit .

10.



- 10 **When fitting a winch only :-** Fit the control box bracket to the bull bar using the M8 x 20 mm bolts and hardware , with the open end of the bracket facing the grill . Leave these bolts finger tight at this stage .

Fit the grommet to the hole in the top of the bull bar and feed the control box cables through the grommet .

11.

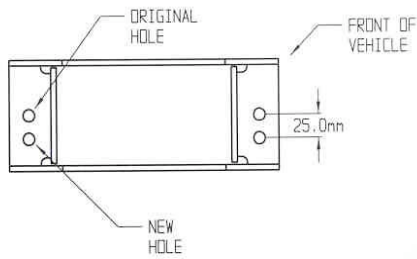

11 **WINCH BAR ONLY** The roller fair lead must be drilled prior to fitment , it can then be assembled into the front of the bull bar along with the winch as detailed in step 14 .

Using a 13.0 mm drill bit drill two holes as shown in diagram 11.

The roller fair lead can then be fitted into the bull bar.

12.

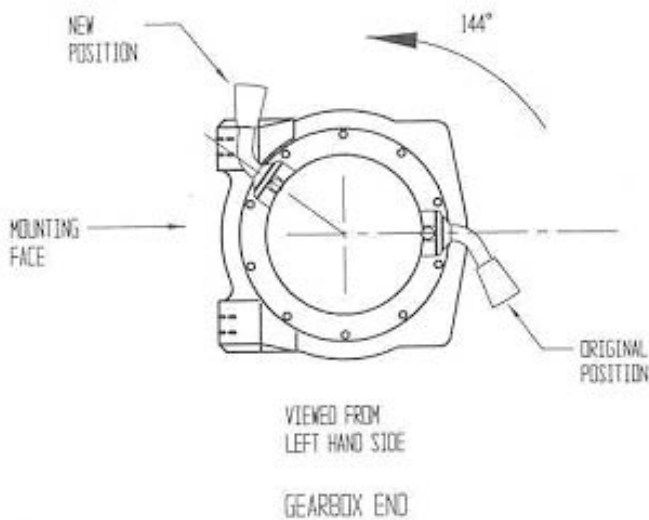

12 To place the winch clutch handle in an accessible location, the gear box must be rotated 2 bolt spaces (144 degrees) in an anti-clockwise direction when viewed from the gear box end .

Place the winch on its end and remove the gear box bolts .Gently raise the gear box just enough to rotate it (about 5mm) , **DO NOT COMPLETELY** remove the gear box as this will damage the gasket .

Once in the new position refit all gear box bolts and tighten .

13.

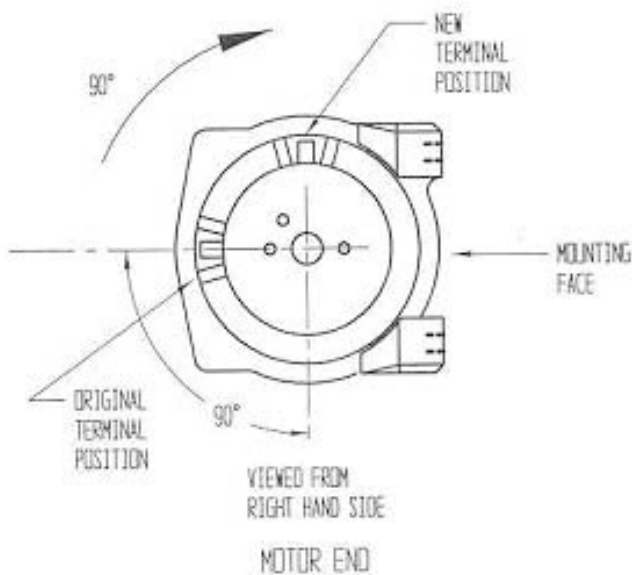

13 The winch motor must also be rotated 90 degrees in a clockwise direction when viewed from the motor end .

Place the winch on its end and remove the 2 bolts holding the motor to the body .Gently raise the motor just enough to rotate it .

Once in the new position re-fit the 2 bolts and tighten

14.



14 With the roller fair lead previously in position , lift the winch into position and bolt into place using the 3/8" hardware supplied with the winch , bolt securely in place .

NOTE :- the gear box is on the left hand side . The winch cable spools from the bottom of the winch drum .

Wire the winch as per the winch instructions . Using the cable ties , tie the wiring back to the rear edge of the bull bar using the holes in the flange . Ensure the wiring is clear of the winch drum & cable etc and does not rub on any hot or moving parts or sharp edges . **Failure to do so could result in damage to the electrical system .**

15.



15 Attached the number plate directly to the bull bar front face using the M6 hardware supplied .

If the bull bar is fitted with a winch use the number plate bracket supplied and fit to the bull bar as shown .

16.



16 With assistance lift the bull bar into position and slide it over the two impact absorbers . Once in position bolt the bull bar in the 8 places using the M10 bolts & hardware supplied , finger tight only at this stage .

Adjust the bull bar on the vehicle until a uniform gap is achieved to the grill & headlamp and guards .Once happy with the position of the bull bar tighten all of the bolts .

The bull bar is then drilled and pinned in its final position using the M10 hardware supplied as shown in the attached photo .

17.



17 Re-connect the fog lamp harness on both sides of the vehicle .

The turn signal is supplied with a loom kit , this is plugged in to the turn signal one end and spliced into the vehicles original wiring at the other end .

Cable tie both the turn signal and fog lamp wiring where appropriate .

Ensure the turn signal & fog lamps are working correctly .

Reconnect the head lamp washer tubes on both sides.

18.



18 Trim the plastic inner guard liners by aligning with the bull bar and using the hole in the wing as a guide , drill a 6 mm hole and secure with the M6 hardware supplied .

