



4X4 ACCESSORIES



DATE:

July 2015

DESCRIPTION:

OME BP-51 High Performance
Bypass Shock Absorbers

APPLICATION:

Jeep Wrangler JK 2007+

PART NO. :

Refer to Table Page 2

AVAILABILITY DATE:

July 2015



PRODUCT SPECIFICATION

ARB IS PROUD TO ANNOUNCE THE RELEASE OF OME BP-51 FOR JEEP JK WRANGLER

ARB 4x4 Accessories, the company that revolutionized the 4x4 world with the Air Locker selectable differential, has now transformed the suspension world with the introduction of the Old Man Emu BP-51 High Performance Bypass Shock Absorbers. Bringing racing technology to your adventures, the OME BP-51 shock absorbers feature revolutionary, patent-pending technology developed by the Old Man Emu engineers to deliver unparalleled on and off road performance.

This application of OME BP-51 High Performance Bypass Shock Absorbers has been engineered specifically for the Jeep JK Wrangler with larger lifts of 3.5 to 4.5 inch. Consisting of 4 shocks and 2 fit kits will fit both the LWB (Unlimited) and SWB variants for all year models from 2006 onwards.

The engineers have designed two front shock absorbers, differing in extended length by 50mm, to fit various suspension heights. This ensures proper wheel travel can be achieved when matched with different coil springs. The BP5160021 has been specifically matched to the Old Man Emu JK 4 inch suspension kit (OMEJK4) and is a direct replacement for the front shock absorber supplied in that kit. A longer version has also been developed (BP5160022) for longer travel applications*. The front fit kit includes all mounting hardware required to fit the shock absorber and reservoir. A lower shock absorber mount has been designed that repositions the shock to provide clearance between the shock body and the chassis rail.

The rear shock has been designed to fit within the factory mounts and includes a stone guard to protect the shaft from front wheel stone damage. The rear fit kit consists of a reservoir piggy back clamp and mounting hardware. It is worth noting the fitting instructions to ensure correct positioning of the reservoir to ensure clearance to other components. Both front and rear shock absorbers will be factory set in compression and rebound. Recommended settings for variations in load and accessory fitment are suggested in the included fitting instructions.

Damping performance is easily adjustable across a wide range in both rebound and compression, allowing the user to alter the vehicle's ride performance and cater for different road conditions and vehicle loading scenarios.

The body, reservoir and components are all made from aircraft grade (6061 T6) aluminum, with a type 3, 40 micron hard anodized finish, ensuring exceptional heat dissipation and resistance to corrosion and stone damage.

Designed, developed and tested entirely by ARB's team of Old Man Emu Ride Engineers. All BP-51 shock absorbers are manufactured in-house by ARB. In order to achieve this, significant investment has been made in state of the art machinery and hard anodizing equipment, allowing ARB total control of the manufacturing process to ensure the highest possible quality.

*As JK Wranglers can be a vehicle with heavy modifications which may include axle upgrades, thorough checking of fit suitability and clearance to other components is recommended as all development was conducted on original equipment. Areas for consideration may include location of shock mounts, bump stop spacing, brake line lengths, coil entrapment and driveshaft travel.

PART NUMBERS:

Part Number	Description	Extended/Compressed Length	Quantity Required	Availability
BP5160021	SHOCK: JEEP 4+ FRONT 633	633mm/395mm (24.9in/15.6in)	2*	July 2015
BP5160022	SHOCK: JEEP 4+ FRONT 683	683mm/420mm (26.9/16.5in)	2*	July 2015
BP5160023	SHOCK: JEEP4+ REAR 685	685mm/422mm (26.9/16.6 in)	2	July 2015
VM80010014	MOUNT KIT: JEEP 4+ FRONT		1	July 2015
VM80010015	MOUNT KIT: JEEP 4+ REAR		1	July 2015

* One set of front shocks required. Extended/Compressed length differences. Choose best suited for your vehicle.

** BP5160021 is specifically designed to work with the OME JK 4" (OMEJK4) suspension system

In the next few months, ARB will be releasing a full 4" kit containing the BP-51 shocks, hardware, brackets and coils similar to the current OMEJK4 kit that is built around the Old Man Emu Sport shocks.



FEATURES:

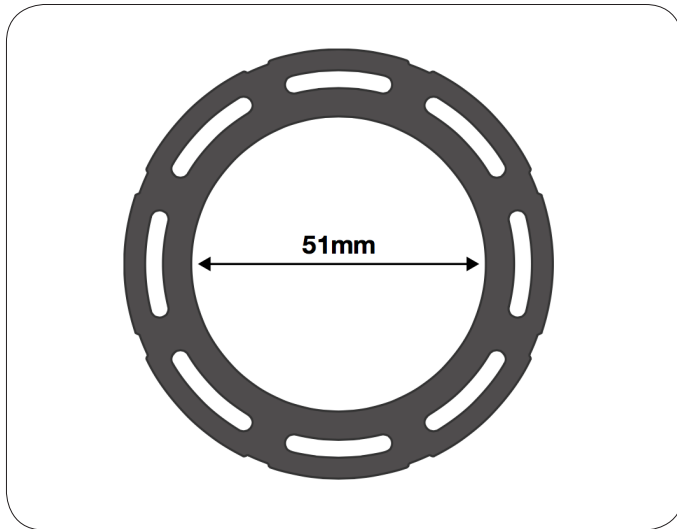

KIDNEY BYPASS PORTS / 51MM BORE DIAMETER

- Maximum bore size & bypass diameter
- Greater oil volume
- More tunable, ability to generate force



EXTERNAL COMPRESSION AND REBOUND ADJUSTMENT:

- Independent adjustment of compression and rebound
- Adjustable while installed on the vehicle
- Ultra wide range to suit varying loads and ride preferences



BODY/RESERVOIR/COMPONENTS 6061 T6 ALUMINIUM:

- Heat dissipation
- Corrosion resistance



INTERNAL BYPASS, SHIM CONTROLLED, POSITION SENSITIVE DAMPING (PATENT PENDING):

- Provides comfort at ride height
- Damping increases as you get closer to the end zone
- Increased control at end zones



DASH 6 HIGH TEMPERATURE TEFLON HOSE WITH HIGH FLOW FITTINGS:

- No restriction of oil flow



LARGE TEFLON LINED SPHERICAL BEARINGS:

- Durability

NOTE: Coil over applications only



ADJUSTABLE SPRING PRELOAD / RIDE HEIGHT:

- Cater for varying loads

NOTE: Coil over applications only. Not a feature on the Jeep Wrangler JK.



HIGH PRESSURE NITROGEN RESERVOIR WITH ALUMINIUM, ANODIZED FLOATING PISTON:

- Increased oil volume
- Maximize travel



IMPACT RESISTANT, REPLACEABLE SHAFT GUARD:

- Protects against stone damage



19MM HARD CHROMED GROUND SHAFT:

- Low friction
- Superior Strength



VEHICLE SPECIFIC APPLICATIONS:

- No fitting modifications required
- Fit kits sold separate from shock absorbers.

ADDITIONAL FEATURES:

100% RE-BUILDABLE AND RE-VALVEABLE:

- Longevity
- Tuneability

HIGH TEMPERATURE VITON AND TEFLON SEAL PACK:

- Durability of seals



TYPE 3 40 MICRON HARD ANODIZED FINISH:

- Corrosion resistance
- Abrasion resistance to stone damage

HIGH PERFORMANCE, HIGH VISCOSITY INDEX OIL:

- Durability and consistency of performance

1900MPA POLISHED, HIGH STRENGTH, HIGH FATIGUE SHIMS:

- Durability
- Superior Strength

3 YEAR / 60000 KM WARRANTY

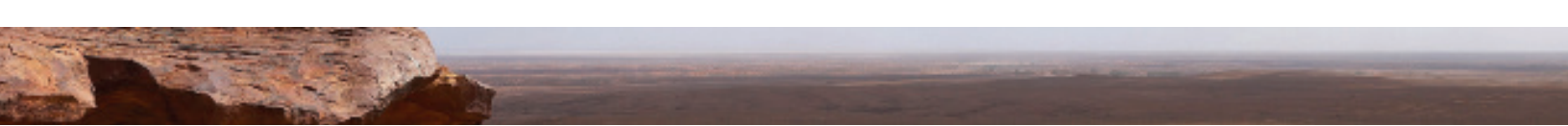

ABOUT ARB 4X4 ACCESSORIES

Founded in 1975 in Melbourne, ARB 4x4 Accessories is now Australia's largest manufacturer and distributor of aftermarket 4WD accessories. With products including bull bars, protection equipment, Old Man Emu suspension, Air Lockers, roof racks, canopies and recovery equipment, our primary mission is to prepare vehicles for the remote and harsh conditions typically encountered off road.

Discover other suspension systems on our website.