



---

# INSTRUCTIONS

---

Part Number: **3450400**  
Product **JK WRANGLER STUBBY BUMPER**  
Description:  
Suited to **2007 ON JK WRANGLER 2 AND 4 DOOR**  
vehicle/s:

## WARNING

### REGARDING VEHICLES EQUIPPED WITH SRS AIRBAG:

When installed in accordance with these instructions, the front protection bar does not affect operation of the SRS airbag.

### ALSO, NOTE THE FOLLOWING:

- ◆ This product must be installed exactly as per these instructions using only the hardware supplied.
- ◆ In the event of damage to any bull bar component, contact your nearest authorised ARB stockist. Repairs or modifications to the impact absorption system must not be attempted.
- ◆ Do not use this product for any vehicle make or model, other than those specified by ARB.
- ◆ Do not remove labels from this bull bar.
- ◆ This product or its fixing must not be modified in any way.
- ◆ The installation of this product may require the use of specialized tools and/or techniques
- ◆ It is recommended that this product is only installed by trained personnel
- ◆ These instructions are correct as at the publication date. ARB Corporation Ltd. cannot be held responsible for the impact of any changes subsequently made by the vehicle manufacturer
- ◆ During installation, it is the duty of the installer to check correct operation/clearances of all components
- ◆ Work safely at all times
- ◆ Unless otherwise instructed, tighten fasteners to specified torque

---

# ARB 4x4 ACCESSORIES

Corporate Head Office

# GENERAL CARE AND MAINTENANCE

By choosing an ARB Bar, you have bought a product that is one of the most sought after 4WD products in the world. Your bar is a properly engineered, reliable, quality accessory that represents excellent value. To keep your bar in original condition it is important to care and maintain it following these recommendations:



- Prior to exposure to the weather your bar should be treated to a Canuba based polish on all exposed surfaces. It is recommended that this is performed on a six monthly basis or following exposure to salt, mud, sand or other contaminants.
- As part of any Pre Trip Preparation, or on an annual basis, it is recommended that a thorough visual inspection of the bar is carried out, making sure that all bolts and other components are torqued to the correct specification. Also check that all wiring sheaths, connectors, and fittings are free of damage. Replace any components as necessary.

## FITTING REQUIREMENTS

### REQUIRED TOOLS FOR FITMENT OF PRODUCT:

BASIC TOOL KIT	TORQUE WRENCH
GRINDER WITH CUTTING DISK	MARKING PEN
BLACK TOUCH UP PAINT	300MM RULE/TAPE MEASURE

### HAVE AVAILABLE THESE SAFETY ITEMS WHEN FITTING PRODUCT:

Protective eyewear		Hearing protection	
--------------------	---	--------------------	---

**NOTE:** 'WARNING' notes in the fitting procedure relate to OHS situations, where to avoid a potentially hazardous situation it is suggested that protective safety gear be worn or a safe work procedure be employed. If these notes and warnings are not heeded, injury may result.

### FASTENER TORQUE SETTINGS:

SIZE	Torque Nm	Torque lbft
M6	9Nm	7lbft
M8	22Nm	16lbft
M10	44Nm	32lbft
M12	77Nm	57lbft

## PARTS LISTING

APPLICATION.	PART NO.	QTY	DESCRIPTION
FIT LIGHT MOUNTS TO BUMPER	3758361R	1	LIGHT MOUNT RHS
	3758361L	1	LIGHT MOUNT LHS
	6151546	6	BOLT M8 X 1.25 X 25 BLACK
	4584324	6	WASHER FLAT M8 BLACK
	4584325	6	SPRING WASHER M8 BLACK
	6151548	6	NUT FLANGE M8 BLACK
MOVE VACUUM PUMP	3194405	1	VACUUM PUMP PLATE
	6151228	1	BOLT M6 X 30 BLACK
	4584295	1	WASHER FLAT M6 BLACK
	6151549	1	NUT M6 NYLOC BLACK
FIT BUMPER TO VEHICLE	3450400	1	BUMPER ASSY
	6151357	8	BOLT M10 X 1.5 SEMS
	6151321	8	NUT FLANGE M10 X 1.5
FIT WINCH, FAIRLEAD & LICENSE PLATE TO VEHICLE	3758359	1	CONTROL BOX BRACKET
	3758362	1	LICENSE PLATE MOUNT – ROLLER
	3758364	1	LICENSE PLATE MOUNT – HAWSE
	3758363	1	LICENSE PLATE HOLDER
	5846214	2	WINCH PACKER 8MM
	6151074	4	BOLT 3/8 X 1 3/4"
	6151098	2	BOLT M12 X 1.5 X 40
	6151136	2	NUT M12 X 1.5
	4581049	4	WASHER FLAT M12
	4581050	2	WASHER SPRING M12
	6151546	2	BOLT M8 X 1.25 X 25 BLACK
	4584324	2	WASHER FLAT M8 BLACK
	4584325	2	SPRING WASHER M8 BLACK
	6151548	2	NUT FLANGE M8 BLACK
	6151550	2	BOLT M6 X 25 BLACK
	6151213	2	BOLT M6 X 20 BLACK
	4584295	6	WASHER FLAT M6 BLACK
	6151549	2	NUT M6 NYLOC BLACK
	6151561	2	NUT M6 FLANGE BLACK
5848302	2	WASHER PLASTIC M6	
FIT JACK PLUGS TO VEHICLE	3163009	2	JACK PLUGS
MISCELANEOUS	180301	4	CABLE TIES

**ASSEMBLY SEQUENCE FOR BULL BAR INSTALLATION.  
PLEASE READ AND UNDERSTAND FITTING INSTRUCTIONS BEFORE  
ATTEMPTING TO FIT BAR TO VEHICLE**



1. To fit a bar to vehicle, the plastic bumper and all hardware behind bumper must be removed from vehicle.

See photos below.



## FITTING PROCEDURE



2. This is how the vehicle must be prepared before fitting a bar to the vehicle. Wrap up and cable tie fog light wiring (if fitted) out of the way.

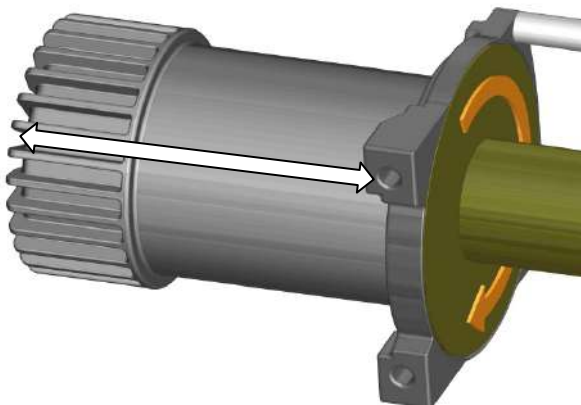

3. If fitting a winch measure the distance between winch mounting hole and the end of the motor. If this distance is greater than 172mm then a notch in the chassis flange must be cut. Follow step 4.

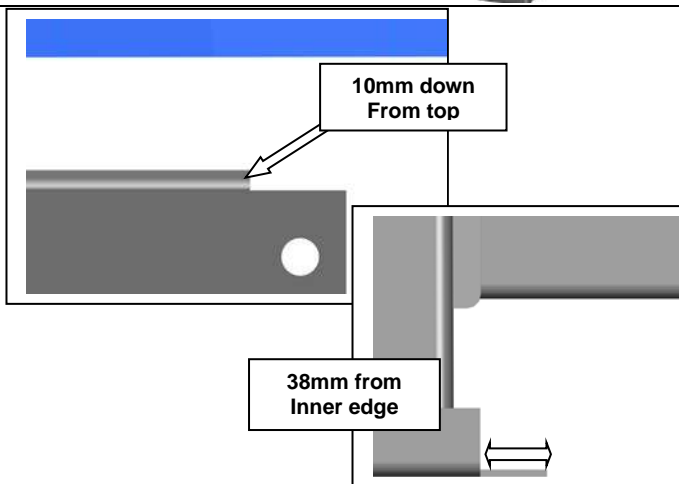

4. Measure from top RH front of chassis down 10mm and mark a line. Measure from inner edge towards chassis centre 38mm and mark a line. Cut this section out using a grinder with cutting disk, de burr and paint.



5. If driving lights are to be used fit left and right driving light mounts now using M8 x 25 bolts, M8 spring washers, M8 flat washers and M8 flange nuts.

Fasten M8 hardware to:



22 Nm.

## FITTING PROCEDURE

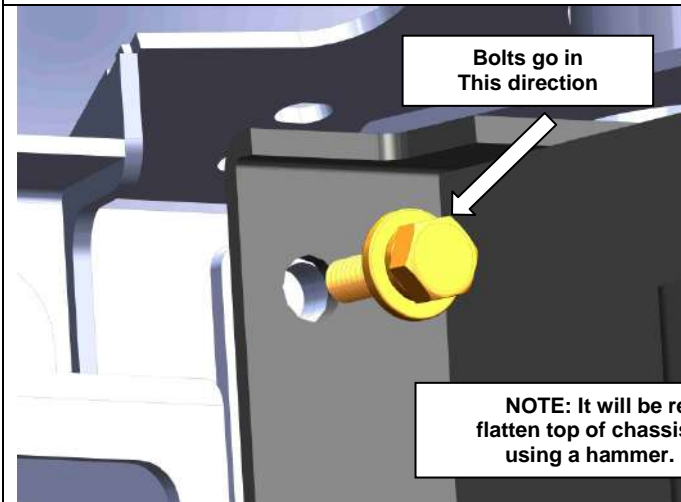

6. Place bar onto vehicle and secure inner mounts using M10 SEMS bolts and M10 flange nuts. Nuts to be placed towards front of vehicle. Make sure vehicle horn is re-fitted, 3.8 V6 on LH side and 3.6 V6 on RH side.

Fasten M10 hardware to:



44 Nm.

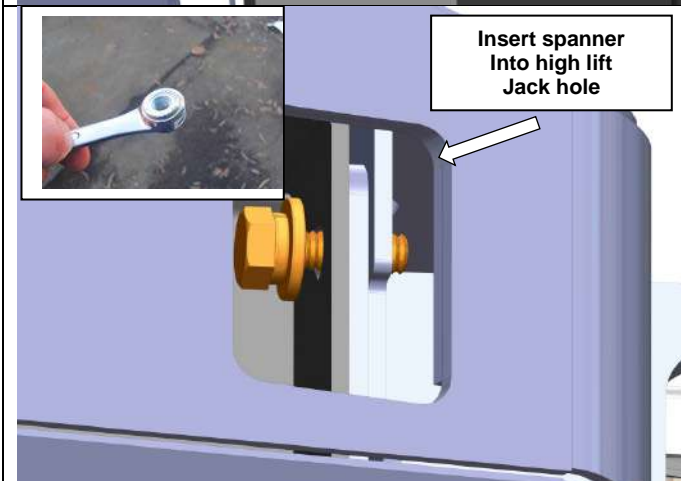
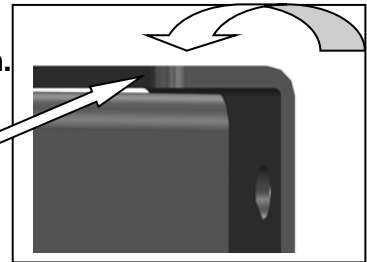

7. To secure outer mounts place flange nut onto ring spanner as shown inset. Feed spanner into high lift jack hole and secure with M10 SEMS bolt through rear face of chassis. If no winch is being used secure license plate to front of bar using M6 x 25 bolts, flat washers and M6 Nyloc nuts.

Fasten hardware to:



44 Nm M10 – 9Nm M6

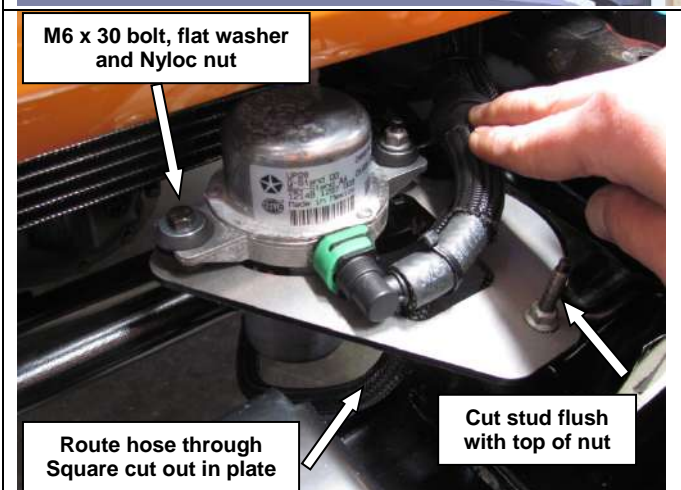

8. Un-bolt vacuum pump and place new mount on chassis as shown. Orientate pump as shown and mount using original nuts on studs and M6 x 30 bolt, flat washer and Nyloc nut on opposite rubber mount. Secure piping using cable ties in kit. NOTE: Cut stud flush with top of nut.



9. On 3.6 V6 models the horn is mounted on the right hand side. Remove the nut mounting the horn to bracket and place horn on opposite face. Rotate horn by hand until sitting horizontal as shown in the image. Trumpet must be facing towards winch mount. Tighten nut when complete.

## FITTING PROCEDURE

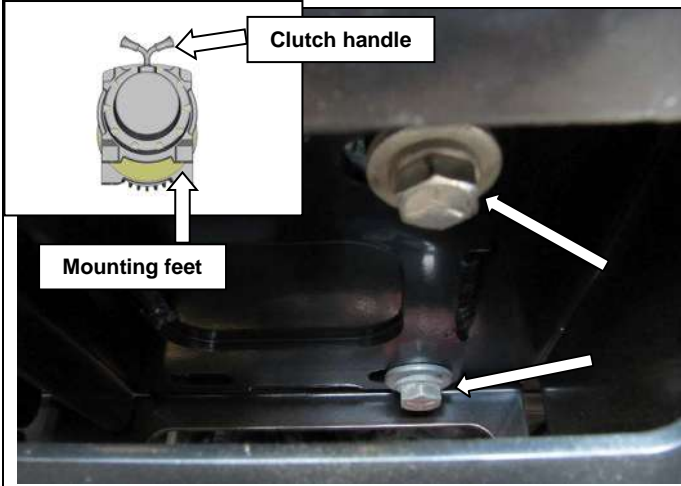

10. Make sure winch clutch handle is facing upwards (opposite mounting feet). If using Warn ZEON or CTI winch use 8mm thick packers and longer 3/8 bolts supplied. Carefully place winch into bar (winch motor on RH side) and secure with hardware supplied with winch through access holes placed in front and rear of bar. Secure to manufacturers torque settings.

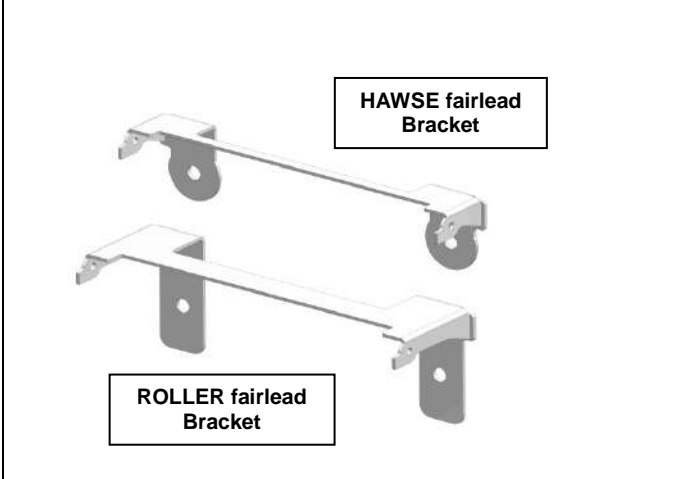

11. If mounting a license plate to the bar with winch choose between a roller fairlead bracket or Hawse fairlead bracket.
12. A control box mounting bracket is also supplied if not mounting control box to winch. Secure to top of bar using black M8 hardware.

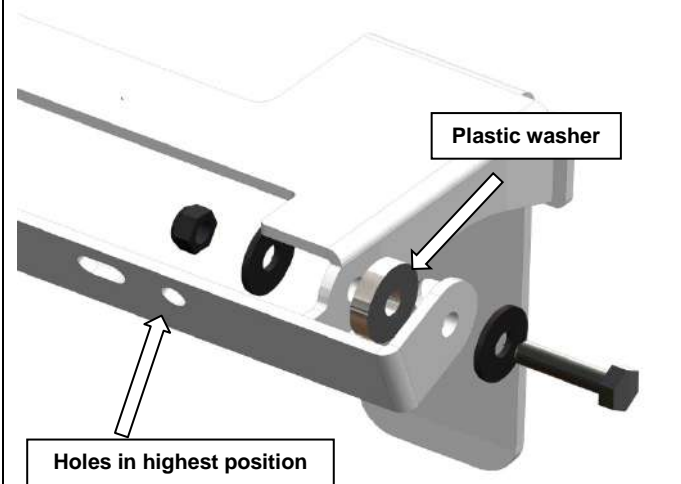
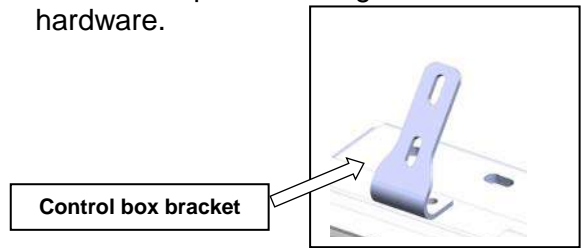

13. Assemble pivoting license plate bracket as shown. Place plastic washer between holder and bracket and secure using M6 x 25 bolts, flat washers and M6 Nyloc nuts. Make sure license plate holes in pivoting bracket are in the higher location.

Fasten M6 hardware to:

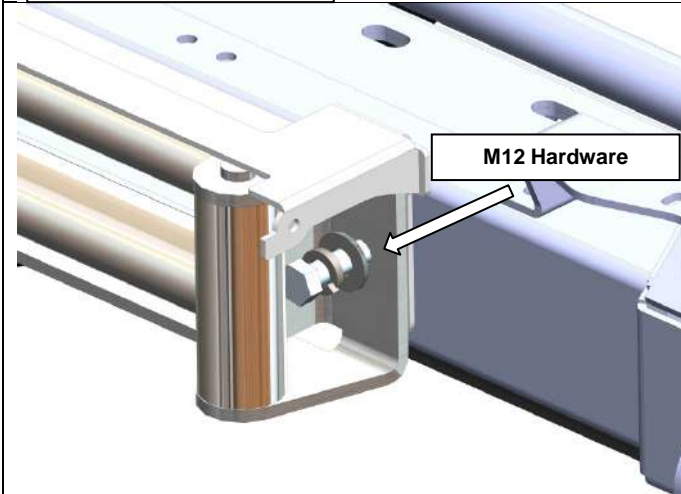

14. Place winch cable through fairlead and sandwich license plate mount between fairlead and bar. Secure using M12 bolts, flat washers, spring washers and M12 nuts. Secure license plate to holder using M6 x 20 bolts, flat washers and M6 flange nuts.

Fasten hardware to:



## FITTING PROCEDURE

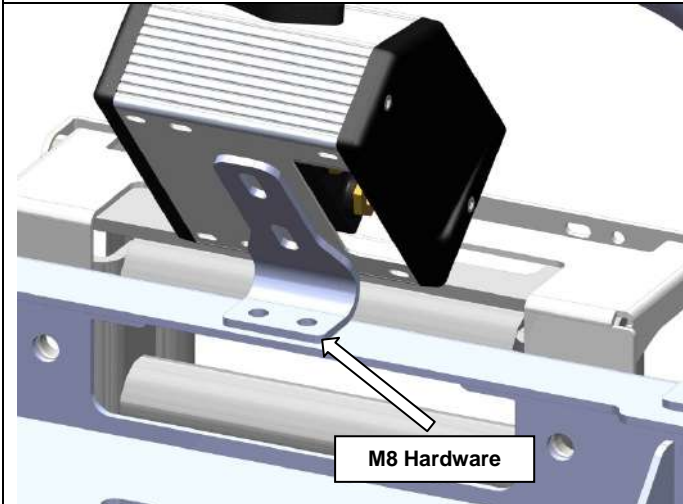

15. If mounting a control box on the bar secure mount to bar using M8 x 25 bolts, M8 spring washers, M8 flat washers and M8 flange nuts. Secure control box to bracket using manufacturers' hardware.

Fasten M8 hardware to:



16. The top tube mount can be used for LED light bars or fitting of radio aerials.

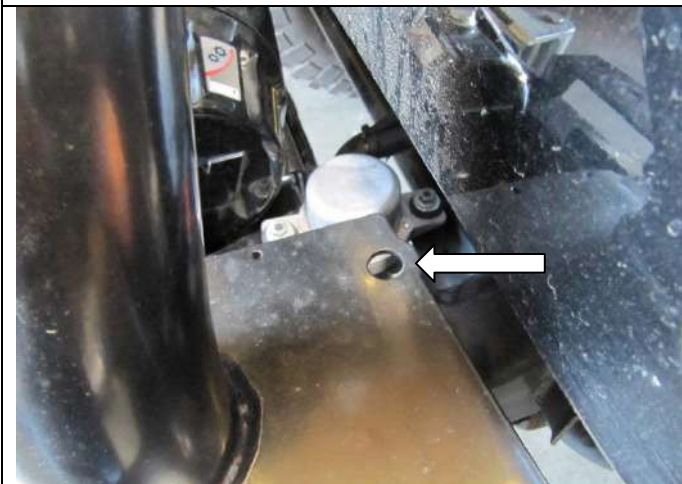

17. An aerial can also be mounted to the top of the bar wing as shown. NOTE: Aerials with large bases may foul bodywork.



18. Fit high lift jack plugs to bar.



## FITTED PRODUCT



ARB provides the best in off-road bumpers.