

ARB FITTING INSTRUCTIONS

NISSAN XTERRA (USA) WINCH BULL BAR 97 ON

No 3438110

WARNING

THIS BULL BAR MUST NOT BE FITTED TO AIRBAG EQUIPPED VEHICLES. FITMENT TO AIRBAG EQUIPPED VEHICLES MAY INTERFERE WITH THE PROPER OPERATION OF THE AIRBAGS AND MAY RESULT IN SERIOUS INJURY.

TAKE NOTE OF THE FOLLOWING:

- **THIS PRODUCT MUST BE INSTALLED EXACTLY AS PER THESE INSTRUCTIONS USING ONLY THE HARDWARE SUPPLIED.**
- **IN THE EVENT OF DAMAGE TO ANY BULL BAR COMPONENT, CONTACT YOUR NEAREST AUTHORISED ARB STOCKIST. REPAIRS OR MODIFICATIONS TO THE IMPACT ABSORPTION SYSTEM MUST NOT BE ATTEMPTED.**
- **DO NOT USE THIS PRODUCT FOR ANY VEHICLE MAKE OR MODEL, OTHER THAN THOSE SPECIFIED BY ARB.**
- **DO NOT REMOVE LABELS FROM THIS BULL BAR.**
- **THIS PRODUCT OR IT'S FIXING MUST NOT BE MODIFIED IN ANY WAY.**

FITTING KIT No 6171371

6151040	4	BOLT M10 X 30 X 1.25mm
4581048	4	WASHER SPRING M10 X 1/8" X 1/8" ZP
4581040	8	WASHER FLAT 3/8" X 1" X 16"
3751581	1	BRKT CONTROL BOX
6151180	2	BOLT M6 X 20mm
EG50	1	RUBBER GROMMET
3751595	1	BRKT NUMBER PLATE
6151017	8	BOLT M6 X 16 X 1mm HEX
6151128	10	NUT M6 FLANGE
6151046	10	WASHER FLAT 6mmZP
6151100	2	BOLT 1 1/2" UNC X 1/2"
6151138	2	NUT UNC 1/2" ZP
4581007	4	WASHER FLAT 13mm x 40mm HD
4581050	2	WASHER SPRING 1/2" X 1/8" X 1/8" ZP
6151110	2	BOLT 5/8" x 6" UNC
6151140	2	NUT NYLOC 5/8" UNC
4581051	4	WASHER FLAT 5/8"
3500080	1	INDICATOR KIT AND LOOM

TOOLS REQUIRED

Basic tool kit, drill with 12mm drill bit

Assembly sequence for winch installation.

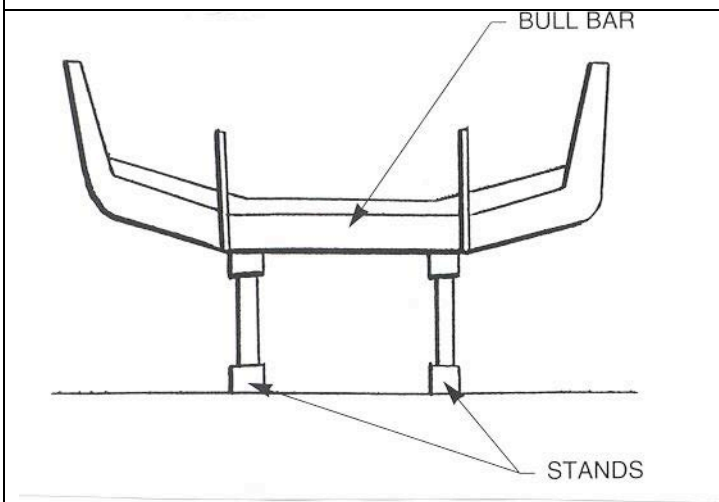

Rest bull bar face down on two stands so that the winch can be easily installed.

Attach control box bracket to bar using two M6 x 20mm bolts

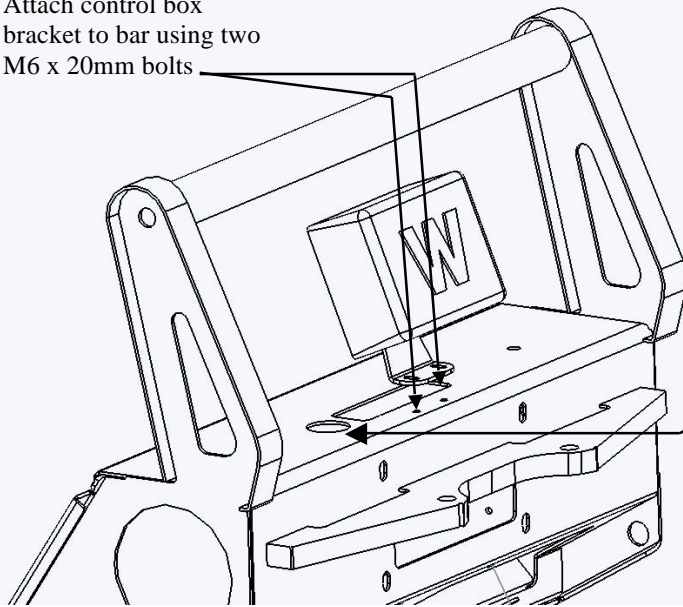

Assemble the control box bracket (Part No. 3751180) onto the control box, fastening with control box nuts. Insert rubber grommet supplied in bolt kit into control box cable hole and run cables through. Fix control box bracket to bar using M6x20mm bolts, flat washers and flange nuts from bolt kit (2 of each item).

Rubber Grommet

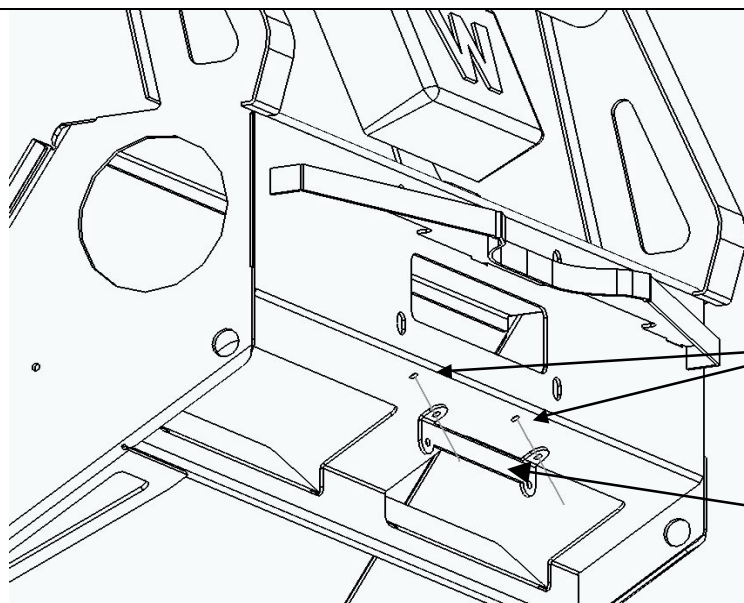

Assemble number plate bracket (Part No. 3751595) onto bull bar using M6x16mm bolts, flange nuts and 6mm flat washers (2 of each item), fastening through number plate mount holes.

Number Plate Bracket Mounting Holes.

Number Plate Bracket.

Assembly sequence for winch installation.

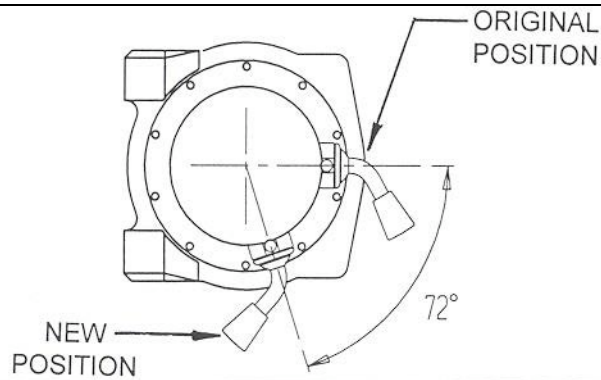

To place winch clutch handle in a convenient location the winch gearbox must be rotated 2 hole spacings, 72 degrees, in a clockwise direction. Place winch on its end and remove all gearbox bolts. Gently raise gearbox just enough to rotate it. Do not completely remove gearbox and avoid damage to the gasket. Refit all bolts and tighten

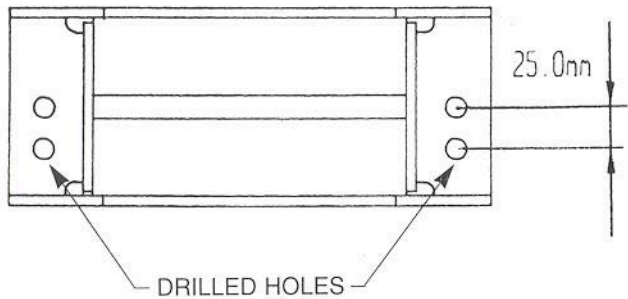

The roller fairlead must have new holes drilled to allow for correct wire rope angle. Using a 12mm diameter drill bit, redrill the fairlead in the position shown in the diagram.

Using the 5/8" x 6" bolts, place the 5/8" flat washers (2 of each item) under the head of both bolts and insert the bolts through the roller fairlead bracket and side rollers. Fit the 5/8" flat washers and nyloc nuts (2 of each item), then tighten so that the rollers turn freely.

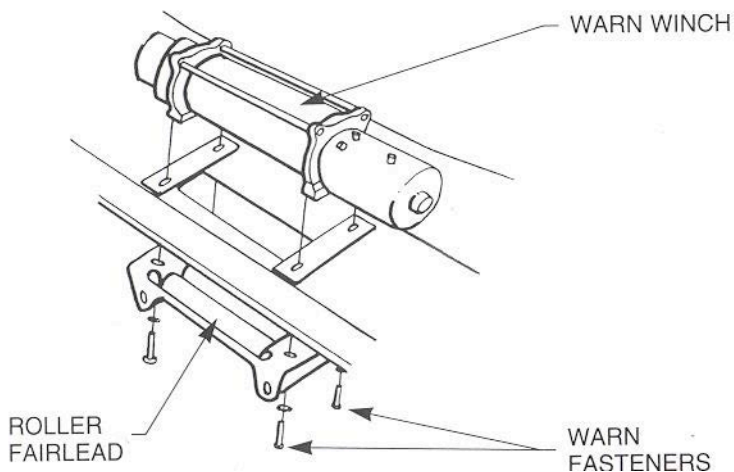

Install the winch and roller fairlead using, bolts, nuts and spring washers supplied by Warn, and 3/8" flat washers (4 off) supplied in bolt kit. Refer to Warn installation instructions for correct procedure. Adjust winch in slots until winch clutch lever can rotate freely in air vent opening on bull bar.

Connect the winch control box cables to the winch motor. Refer to the Warn handbook for additional information. Connect the long winch + & - cables to the vehicle after the bull bar is installed. Refer to the Warn winch manual for vehicle wiring instructions.

Assembly sequence for bull bar installation.

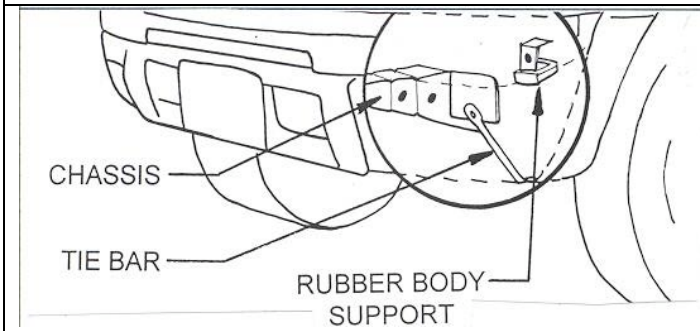

Remove existing bumper from vehicle by removing chassis bolts, outer tie bars and bolts connecting rubber body supports to the vehicle.

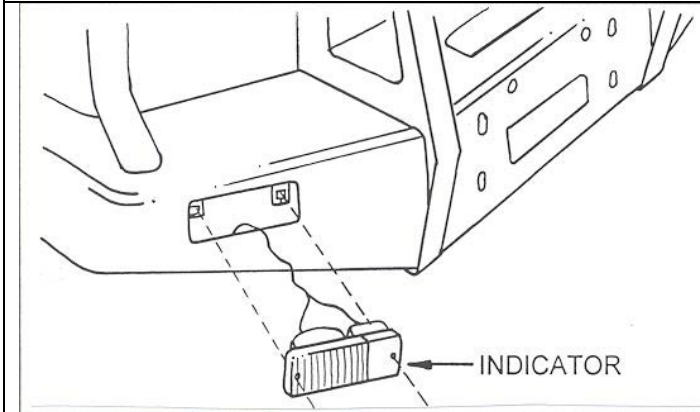

Fit plastic screw plugs provided in indicator kit to bull bar and install indicator lamps using self tapping screws provided with lamps.

Connect harness to wires in vehicle lamp harness using scotch locks provided.

Fasten number plate to the number plate bracket.

Fasten the number plate using M6x16mm bolts, flange nuts and 6mm flat washers (2 of each item).

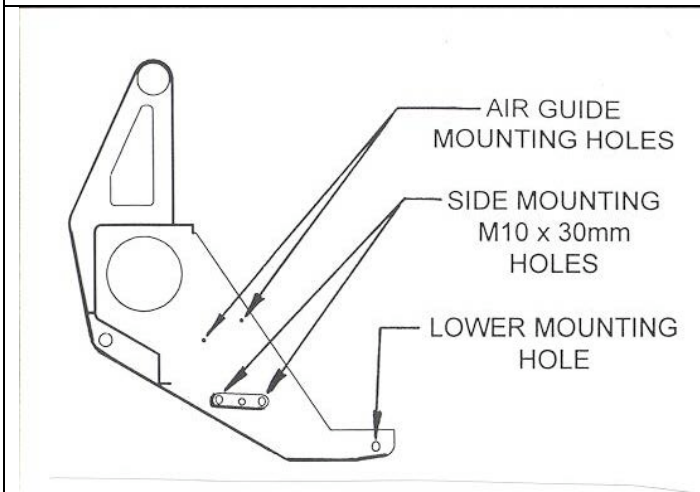

NOTE- If the vehicle is fitted with A/C, remove lower air guide from existing bumper. Using side cutters, trim back the wide sections on the front outer flanges to allow air guide to be fitted to bull bar. Install the M6x16mm bolts, flange nuts and 1/4" flat washers (4 of each item).

Using 3 people carefully lift the bull bar up to the vehicle and position so it can be side mounted to captive nuts in chassis. Fasten with M10 x 30mm bolts, spring washers and 3/8" flat washers (4 of each item).

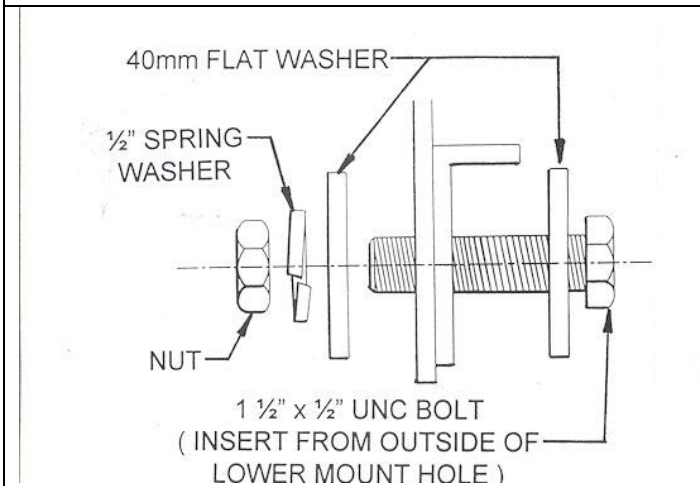

Bolt through lower mount hole using the 1 1/2" x 1/2" UNC bolts, spring washer, nut (2 of each item) and 13 x 40mm flat washer (4 off). Bolt through hole from outside as per diagram, diagram has passenger side drawn.

Align bull bar to the vehicle and tighten the mount bolts to the following torques, M10 bolts to 44Nm and 1 1/2" x 1/2" UNC bolts to 77Nm.

NOTE- After fitment bounce vehicle to settle suspension. Check front suspension "H" dimension and adjust if necessary. Refer to D22 workshop manual for specifications.