



OVERVIEW

Spanning up to 71 inches over its optimized 2D airfoil shape, the APR Performance GTC-250 Adjustable Wing supplies maximum downforce in widebody sports and touring car applications.



GT-250 Dual Element

DOWNFORCE BALANCE

FRONT



CENTER



REAR



The Downforce Balance graph (shown at the left) illustrates which areas of the vehicle this product affects.

There are three (3) areas: Front, Center, and Rear. The size of the red bar represents how much this product affects each particular area.

BENEFITS

Best-in-class Lift vs Drag (L/D) ratio ensures peak performance
Angle adjustment holes allow for easy tuning of downforce
Reinforced pre-preg carbon fiber withstands extreme loads

SPECIFICATIONS

Pattern

2x2 twill weave

Material

Pre-preg carbon fiber, 3K

Coating

UV-stable clear coat

Wing measurement

Custom span Up to 71", 10" chord

Hardware

Stainless-steel machine screws, washers, and nuts

Mounting

6061 billet aluminum brackets/pedestals with
application-specific bottom mounting bases

FEATURES

The APR Performance GT-250 Adjustable Wing features a 2D airfoil shape that is designed to produce great downforce with minimal drag.



The GT Series airfoil is composed of lightweight and durable pre-preg carbon fiber composite materials for superior strength and low weight.

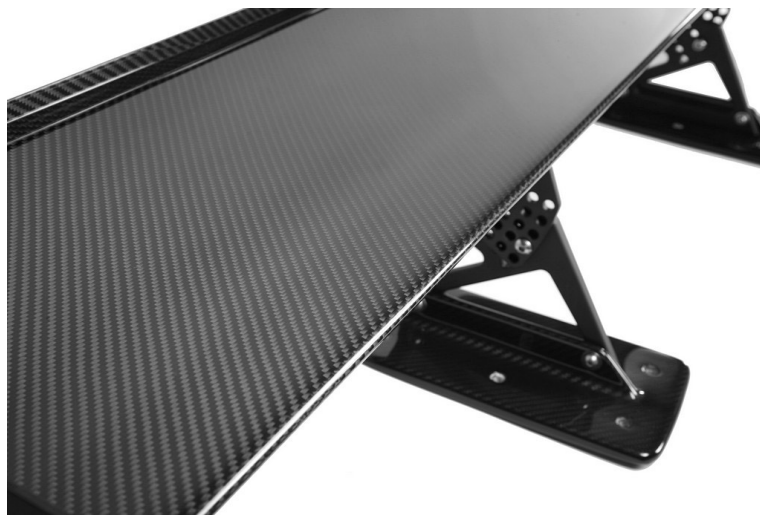

Side plate angles are easily adjusted using the included stainless-steel hardware.



Supporting the airfoils are 10mm "aircraft grade" 6061 billet aluminum pedestals that come in a flat black powder coat finish.



Computational Fluid Dynamics (CFD)

Modeled in 3D and validated using Computational Fluid Dynamics (CFD), the APR Performance GT-250 Adjustable Wing is designed to adapt to a variety of widebody sports and touring car applications.

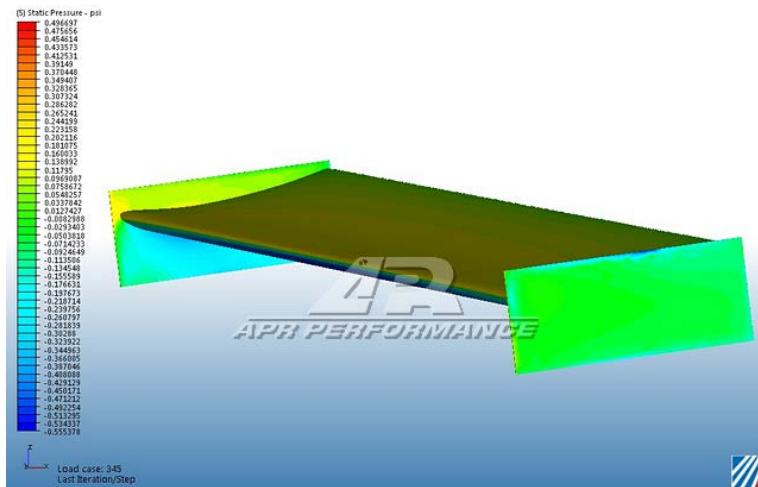

CFD DATA FOR THE GT-250 ADJUSTABLE WING

OVERVIEW

Contained herein are the data and results of the Computational Fluid Dynamics (CFD) analysis that was conducted on the GT-250 airfoil. This data illustrates how the airfoil performs in different conditions by comparing Downforce vs. Angle-of-Attack (AOA) vs. Speed, and Drag vs. AOA vs. Speed. This data will provide insight with regards to how and how much the airfoil performs with respect to these conditions.

To learn how to interpret and apply this type of CFD data, see sample analysis on the [GTC-300 page](#).

APR WING CFD DATA **PROFILE: APR005 SINGLE ELEMENT** **2011.10.31**
All values are pound force (lbf) **updated: 2013.3.18**
Fz = Lift **Fx = Drag** **L/D = Lift/Drag ratio**
Positive Fz values are downforce

Prepared by: **AMB Aero**

AOA	Fz	Fx	L/D	Speed
0	43.79	3.63	7.26	80
0	104.46	14.11	7.40	120
0	190.15	26.62	7.14	160
5	71.81	9.81	7.32	80
5	166.15	22.22	7.48	120
5	300.13	39.62	7.57	160
5 + gurney	482.34	72.16	6.68	160
10	131.10	19.44	6.74	80
10	301.15	49.54	6.08	120
10	540.15	71.86	7.52	160
10 + gurney	705.75	109.96	6.42	160
16	171.39	32.44	5.28	80
16	379.78	71.12	5.34	120
16	675.16	126.43	5.34	160

Efficiency by AOA

	80 MPH	120 MPH	160 MPH
0 AOA	7.26	7.40	7.14
5 AOA	7.32	7.48	7.57
10 AOA	6.74	6.08	5.89
16 AOA	5.28	5.34	5.34

Downforce

	80 MPH	120 MPH	160 MPH
0 AOA	43.79	104.46	190.15
5 AOA	71.81	166.15	300.13
10 AOA	131.10	301.15	540.15
16 AOA	171.39	379.78	675.16

APR PERFORMANCE

Drag

	80 MPH	120 MPH	160 MPH
0 AOA	3.63	14.11	26.62
5 AOA	9.81	22.22	39.62
10 AOA	19.44	49.54	71.86
16 AOA	32.44	71.12	126.43

Wing forces

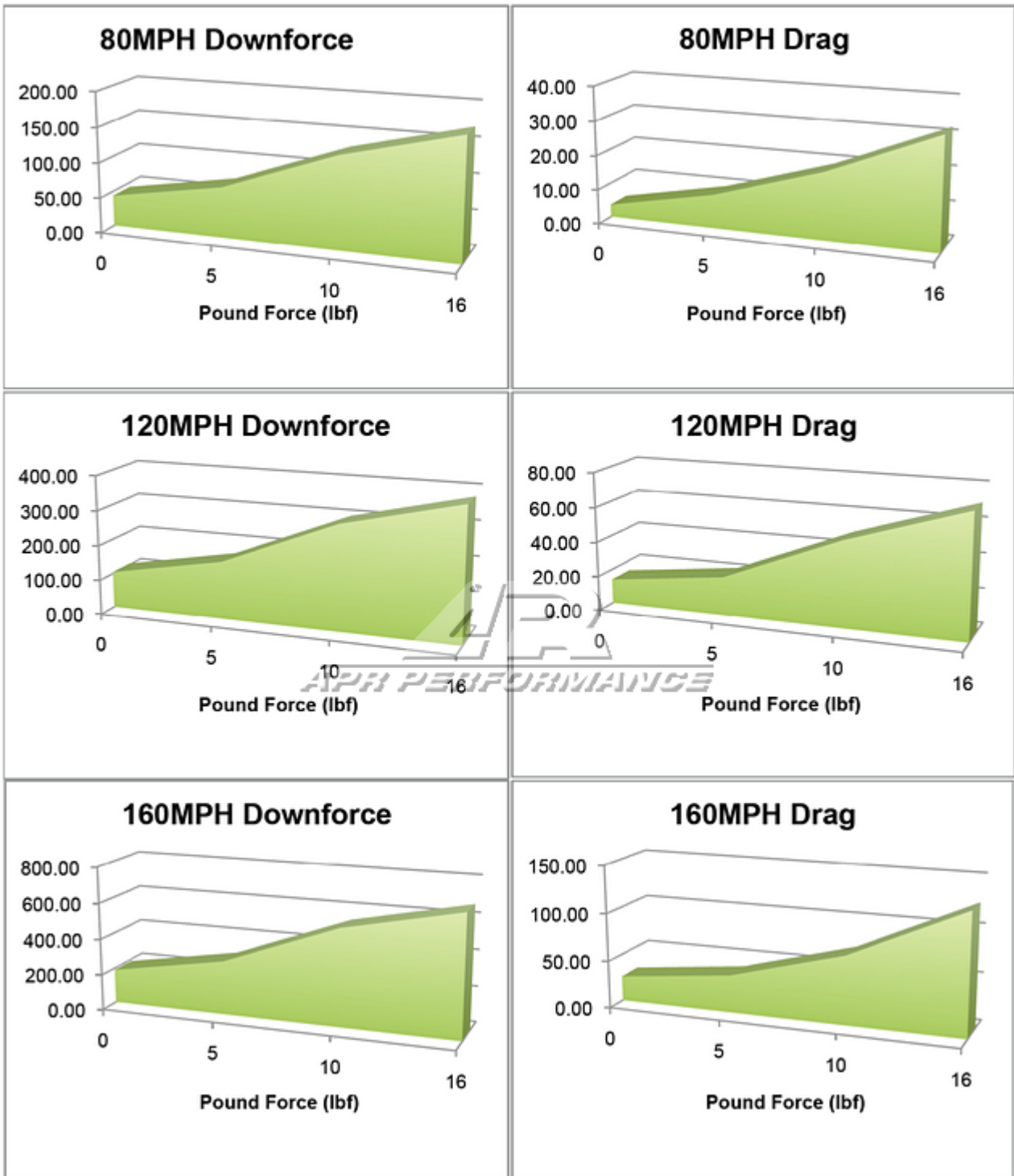

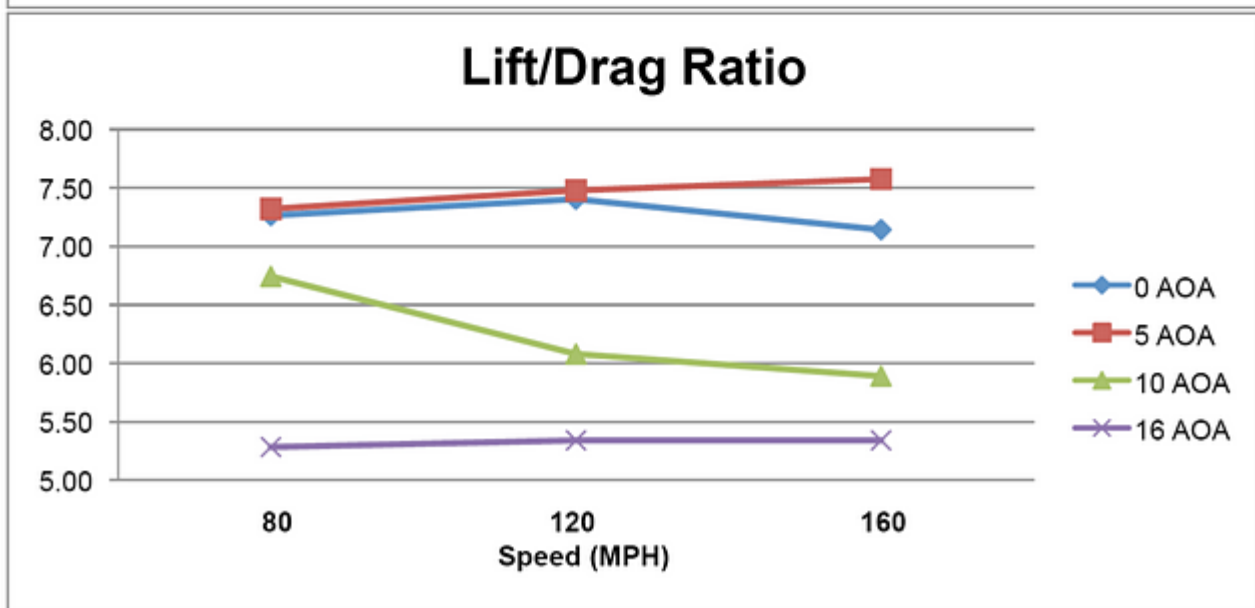
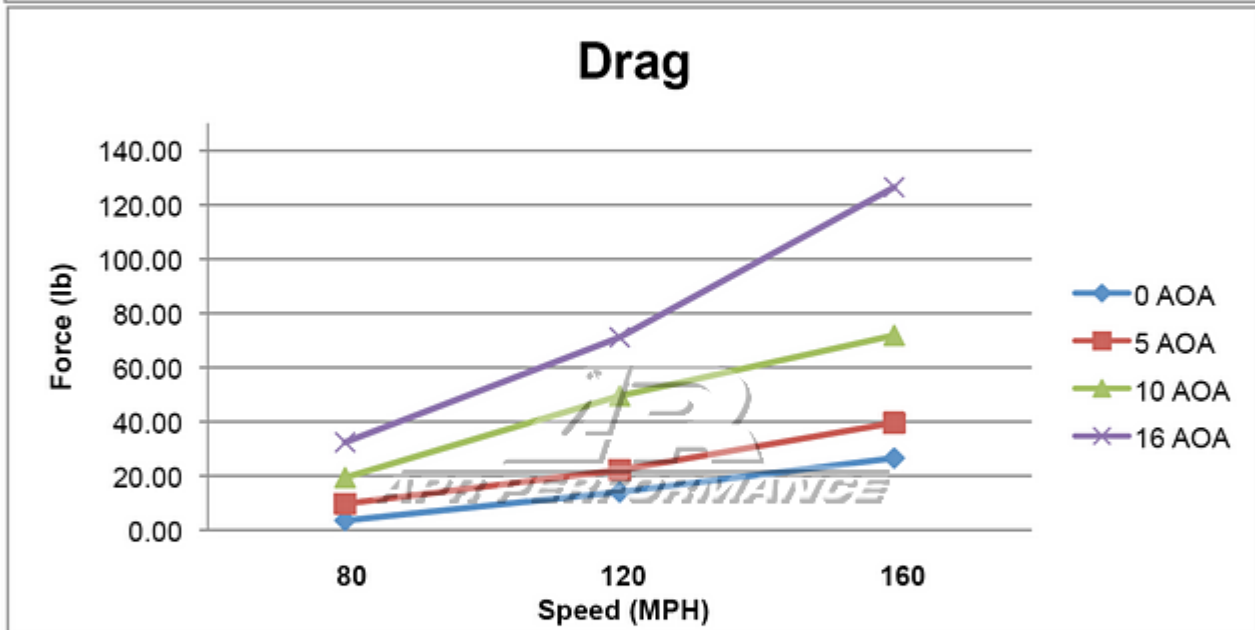
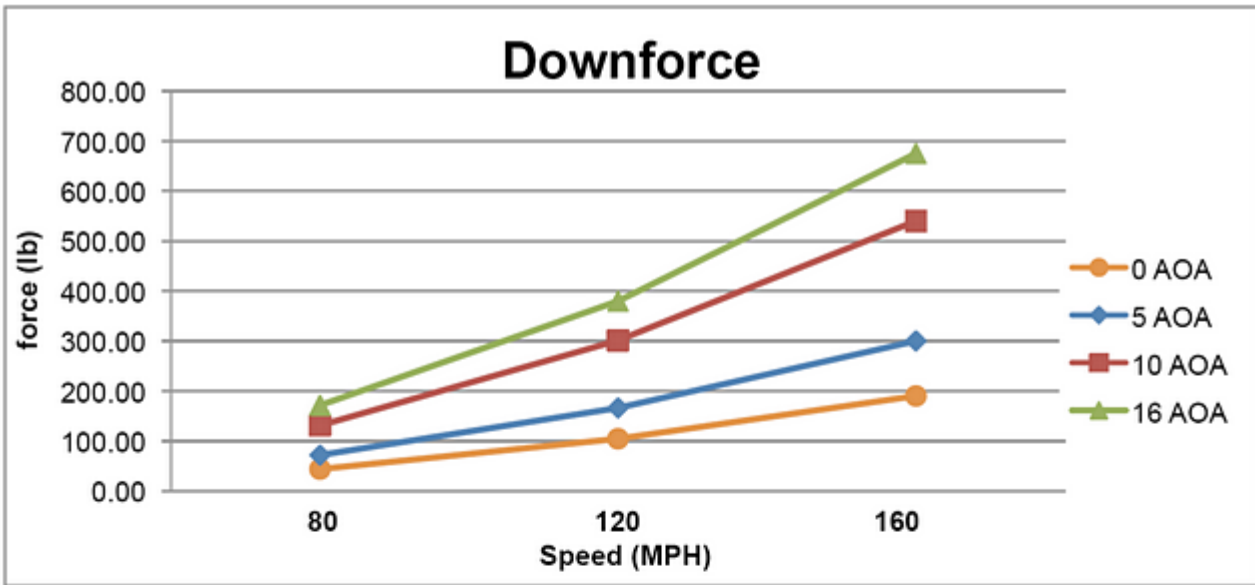

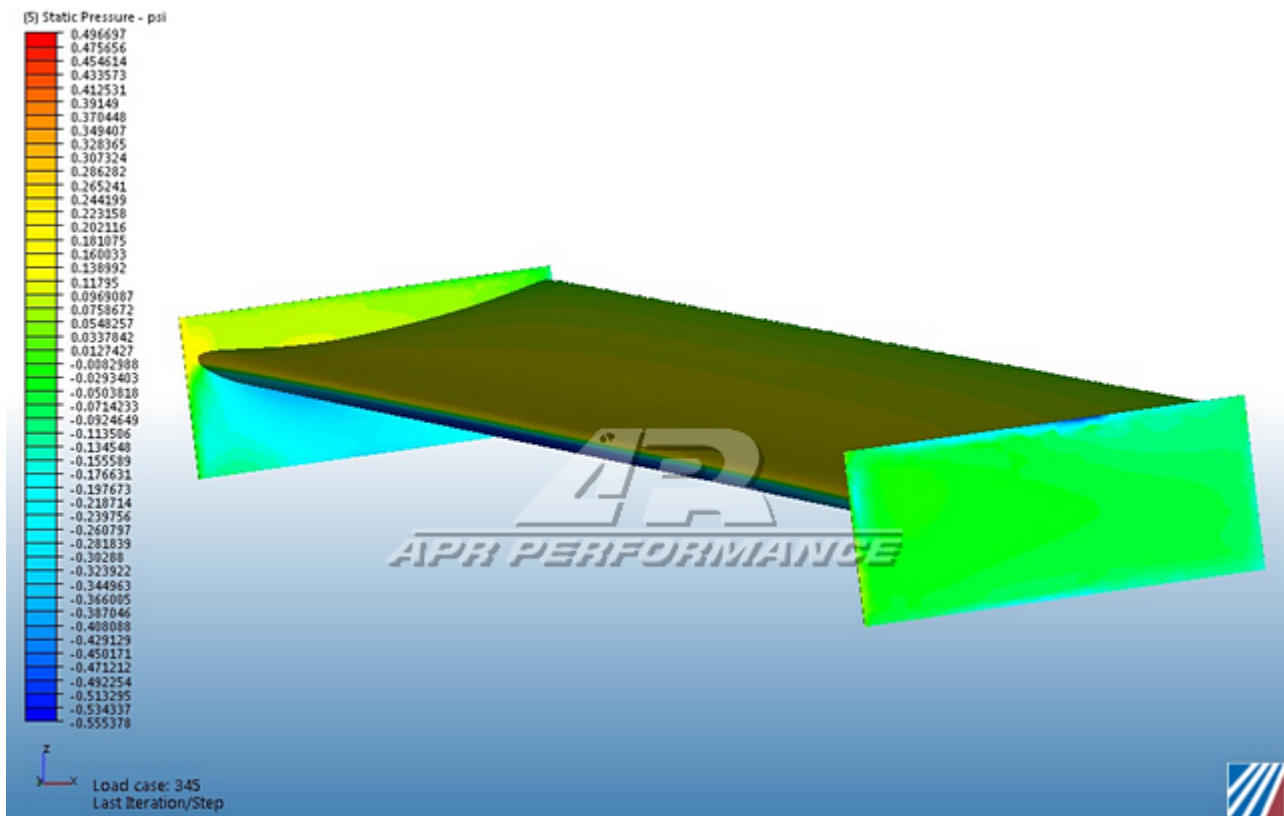
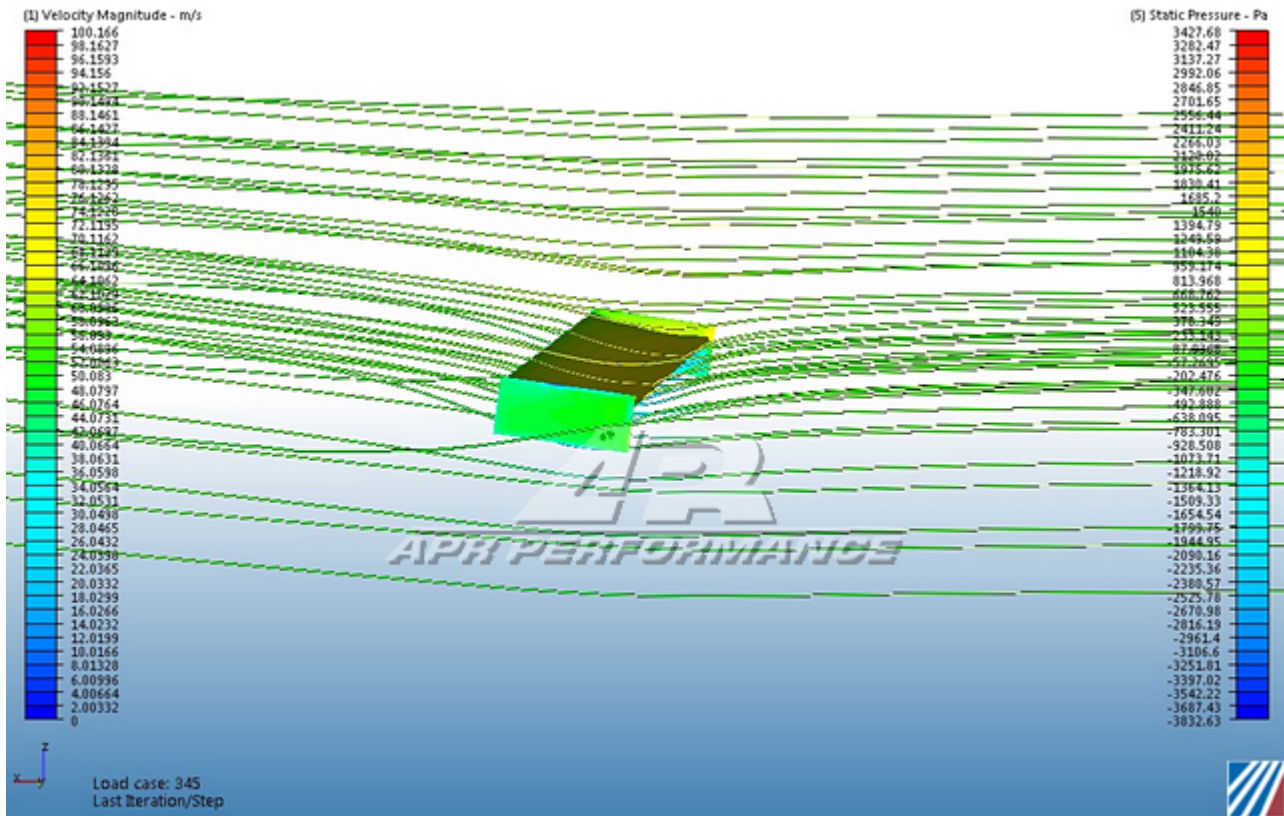

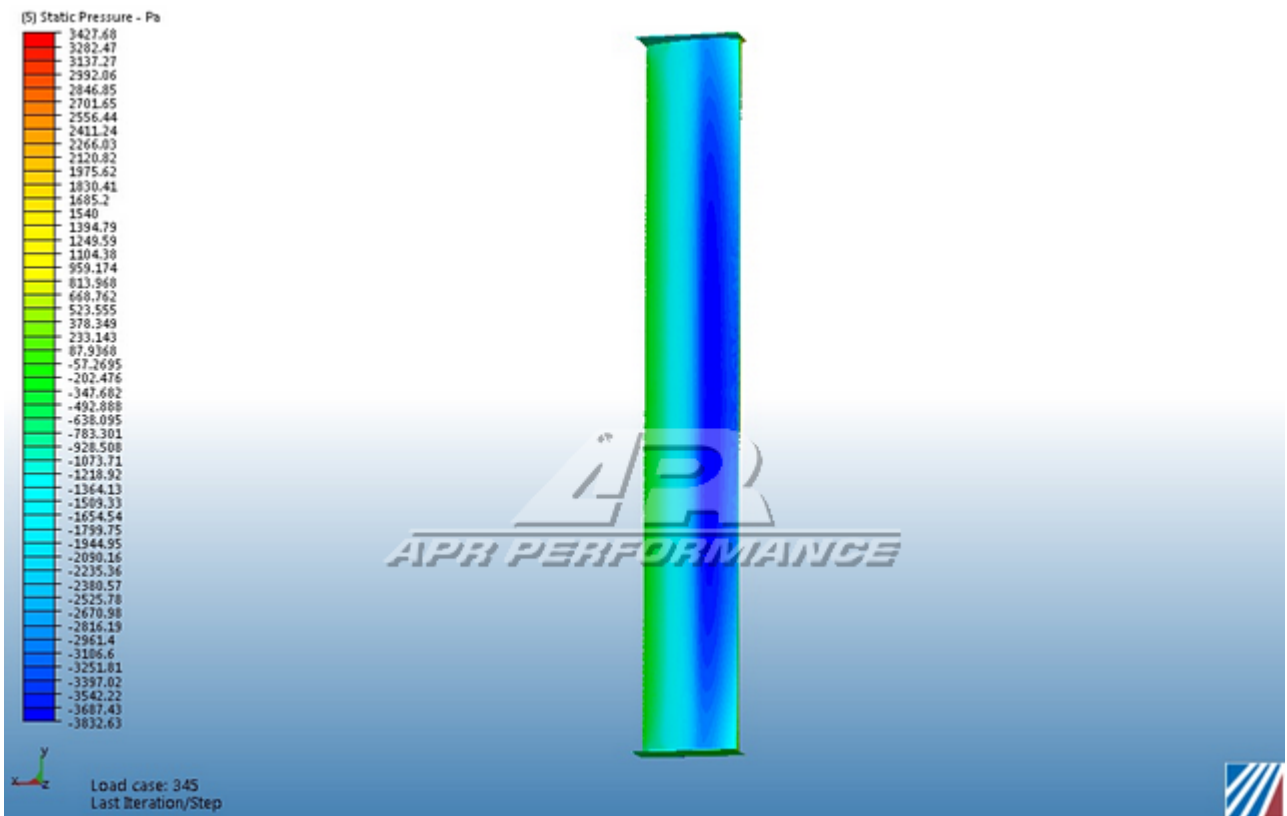
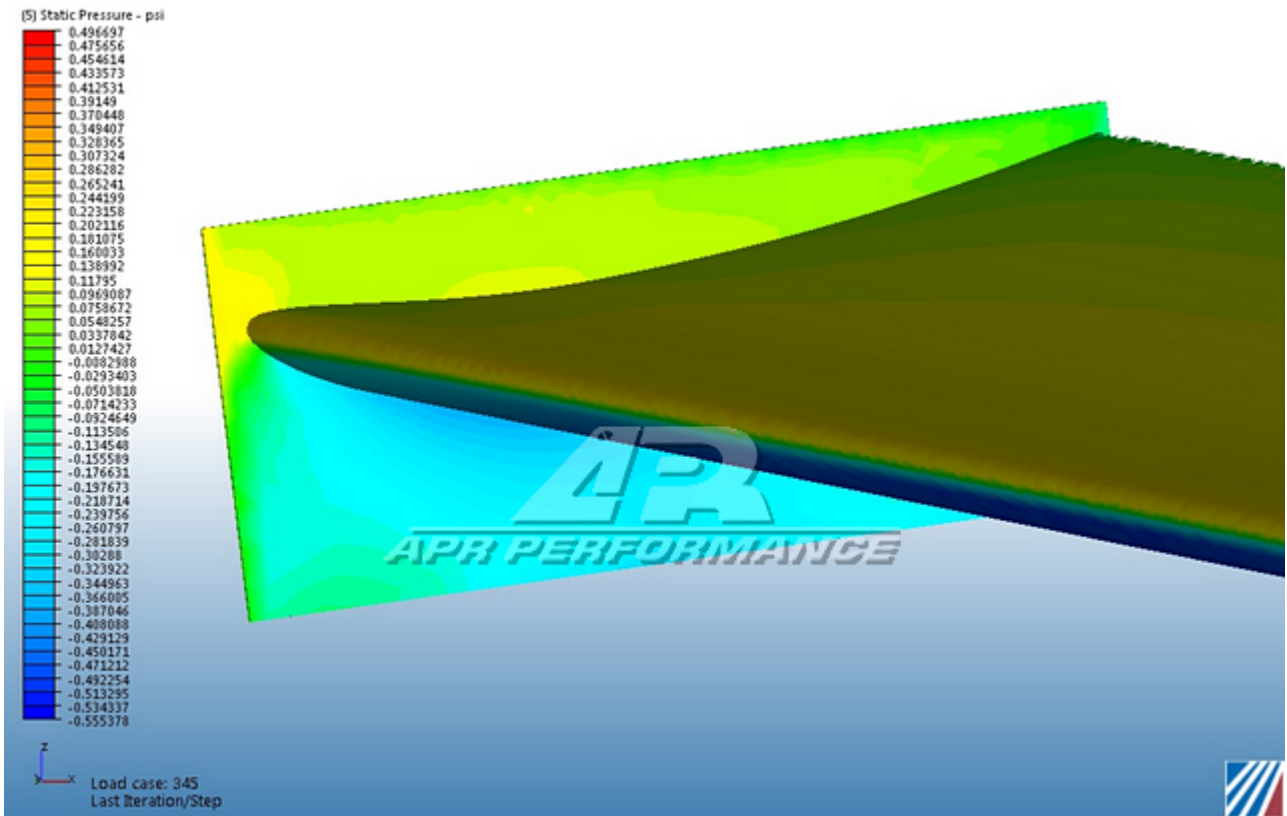

The information contained herein is property of APR Performance, and may not be reproduced in whole or in part without prior written consent from APR Performance.

Gurney Flaps

Gurney flaps are included with every APR Performance GT-250 Adjustable Wing. These are super lightweight, made using pre-preg carbon fiber processes, and pre-attached using double-sided tape.



HISTORY OF THE GURNEY FLAP

The Gurney flap (a.k.a. wickerbill) is an aerodynamic device that was originally pioneered and developed in the 1970s by a racing driver named Dan Gurney. Unbeknownst to his competition, this device was used to increase downforce while minimizing increase in drag. He found that not only did this device increase the lift/drag (L/D) ratios, it also increased the stalling angles (so he could operate the airfoils at greater pitch angles). It took a few years for everyone else to catch on to its purpose, and now, the Gurney flap (or similar device) can be seen in race cars and even airplanes all over the world.