

PARTS LIST:

Item	QTY	Description	Item	QTY	Description
#1	2	Running Board(use for left or right)	#11	4	12mm Lock Washers
#2	1	Driver/Left Front Mounting Bracket	#12	4	12mm x 37mm OD x 3mm Flat Washers
#3	1	Passenger/Right Front Mounting Bracket	#13	16	10mm x 30mm OD x 2.5mm Flat Washers
#4	1	Driver/Left Rear Mounting Bracket	#14	8	10-35mm Hex Bolts
#5	1	Passenger/Right Rear Mounting Bracket	#15	8	10mm Lock Washers
#6	2	Driver Front/Passenger Rear Lower Brackets	#16	8	10mm Hex Nuts
#7	2	Driver Rear/Passenger Front Lower Bracket	#17	24	6-1.0mm x 20mm T-Bolts
#8	4	12mm x 40mm Bolt Plate	#18	24	6mm x 22mm OD x 2mm Flat Washers
#9	4	12mm Plastic Retainers	#19	24	6mm Lock Nuts
#10	4	12mm Hex Nuts	#20		

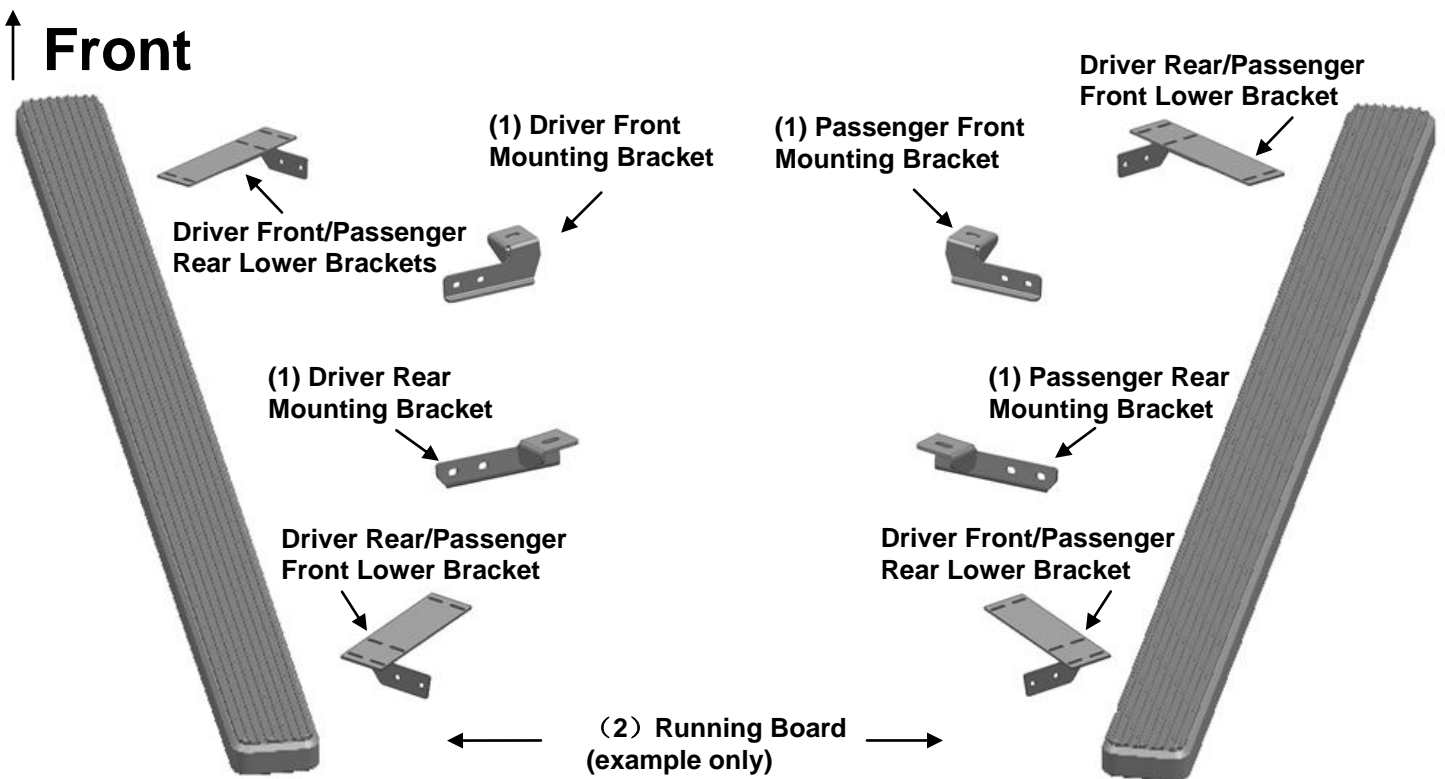

PROCEDURE:

- 1. REMOVE CONTENTS FROM BOX, VERIFY ALL PARTS ARE PRESENT. READ FACTORY BODY BOLT REMOVAL INSTRUCTIONS AND INSTALLATION INSTRUCTIONS CAREFULLY BEFORE STARTING INSTALLATION.**
- Start installation from under the driver side of the vehicle. Remove the plastic plug in the center of the jack pad. **NOTE:** Depending on the year and model of vehicle, either unscrew the plug, **(Figure 1A)**, or pry the plug out of the center of the jack pad, **(Figure 1B)**. Once the plug has been removed, remove the jack pad, **(Figure 1B)**.
- Insert (1) 12mm x 40mm Bolt Plate into the factory hole once the jack pad has been removed, **(Figure 2)**. Select the Driver Front Mounting Bracket. Bolt Driver Front Mounting Bracket to the vehicle with (1) 12mm Lock Washer, (1) 12mm Flat Washer, (1) 12mm Hex Nut and (1) 12mm Plastic Retainers. Do not tighten hardware at this time. **(Figure 3)**

4. Select the Driver Front/Passenger Rear Lower Brackets. Bolt Driver Front/Passenger Rear Lower Brackets to Driver Front Mounting Bracket with (2)10mm x 35 Hex Bolt, (2) 10mm Lock Washer, (4) 10mm Flat Washer and (2) 10mm Hex Nut. Do not tighten hardware at this time. **(Figure 3)**
5. Move toward the rear of the driver side and repeat **Step 2** to remove the driver side rear jack pad.
6. Insert (1) 12mm x 40mm Bolt Plate into the factory hole once the jack pad has been removed, **(Figure 4)**. Select the Driver Rear Mounting Bracket. Bolt Driver Rear Mounting Bracket to the vehicle with (1) 12mm Lock Washer, (1) 12mm Flat Washer, (1) 12mm Hex Nut and (1) 12mm Plastic Retainers. Do not tighten hardware at this time. **(Figure 4)**
7. Select the Driver Rear/Passenger Front Lower Bracket. Bolt Driver Rear/Passenger Front Lower Bracket to Driver Rear Mounting Bracket with (2)10mm x 35 Hex Bolt, (2) 10mm Lock Washer, (4) 10mm Flat Washer and (2) 10mm Hex Nut. Do not tighten hardware at this time. **(Figure 4)**
8. Select a Running Board. Slip(12) 6mm T-bolts into each bottom channel**(Figure 5)**. Carefully position the Running Board onto the (2) Mounting Brackets. **IMPORTANT:** Do not slide, (front to back), the Running Board on the Brackets or damage to the finish may result. Attach the Running Board to the Mounting Brackets with (6) 6mm T-bolts, (6)6mm flat washers and (6)6mm lock nuts **(Figures 6)**. Do not tighten at this time.
9. Level and adjust the running board, and tighten all hardware. Check all mounting locations for clearance between factory steel body mount brackets and Mounting Brackets. Once satisfied with fit, fully tighten all hardware.
10. Repeat **Steps 1—9** for passenger running board installation.
11. Do periodic inspections to the installation to make sure that all hardware is secure and tight.

To protect your investment, wax this product after installing. Regular waxing is recommended to add a protective layer over the finish. Do not use any type of polish or wax that may contain abrasives that could damage the finish.

For Polished Finishes: Aluminum polish may be used to polish small scratches and scuffs on the finish. Mild soap may be used also to clean the Running Board.

For Black Finishes: Mild soap may be used to clean the Running Board.

Driver Side Installation Pictured

Models with threaded plugs: Remove-unscrew factory plastic plug (center) and outer jack pad...

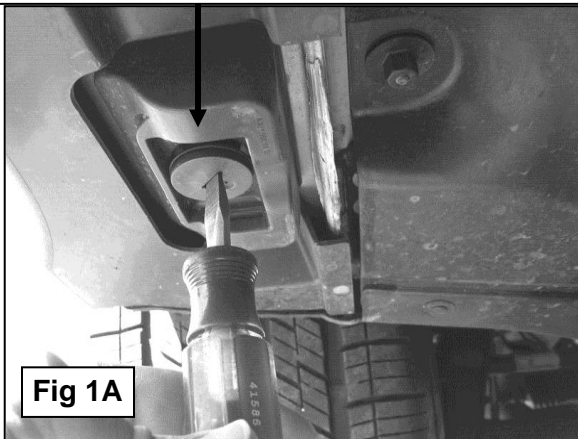

...or use a small screwdriver to pry up the push in factory plastic plug (center) and outer jack pad

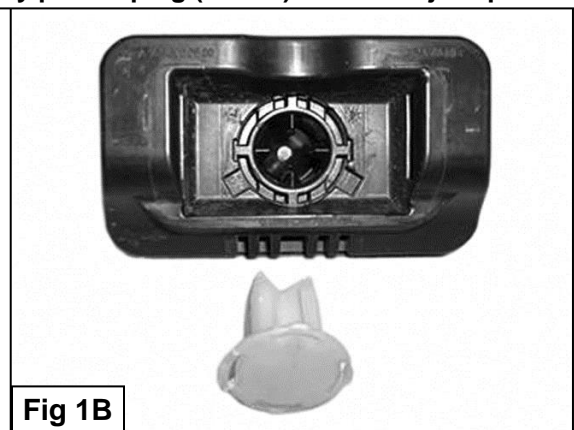

Driver Side Installation Pictured



12mm x 40mm Bolt Plate

Fig 2

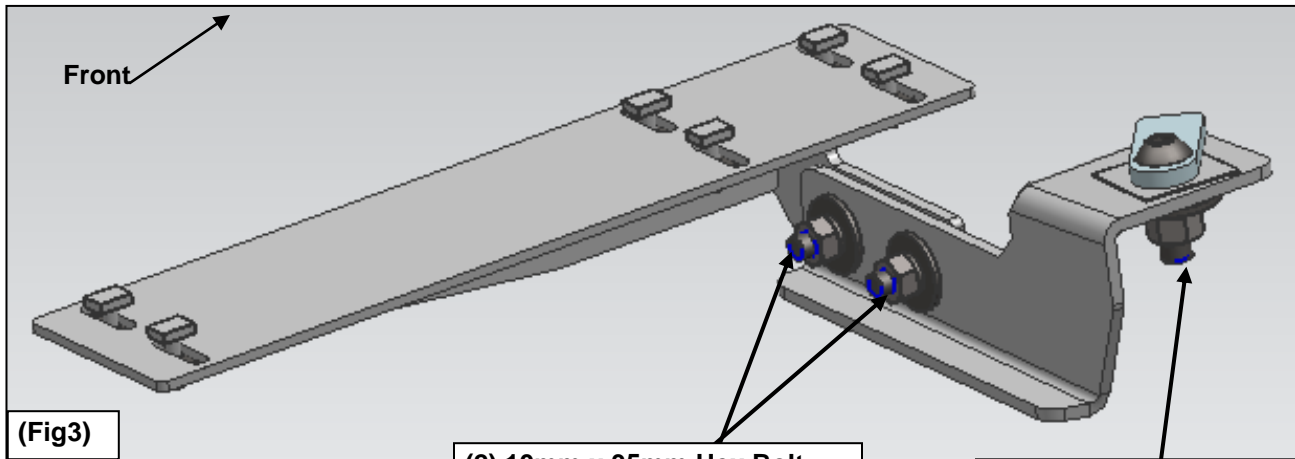

Front

(Fig3)

- (2) 10mm x 35mm Hex Bolt
- (4) 10mm Flat Washer
- (2) 10mm Lock Washer
- (2) 10mm Hex Nut

- (1) 12mm x 40mm Bolt Plate
- (1) 12mm Flat Washer
- (1) 12mm Lock Washer
- (1) 12mm Hex Nut
- (1) 12mm Plastic Retainers

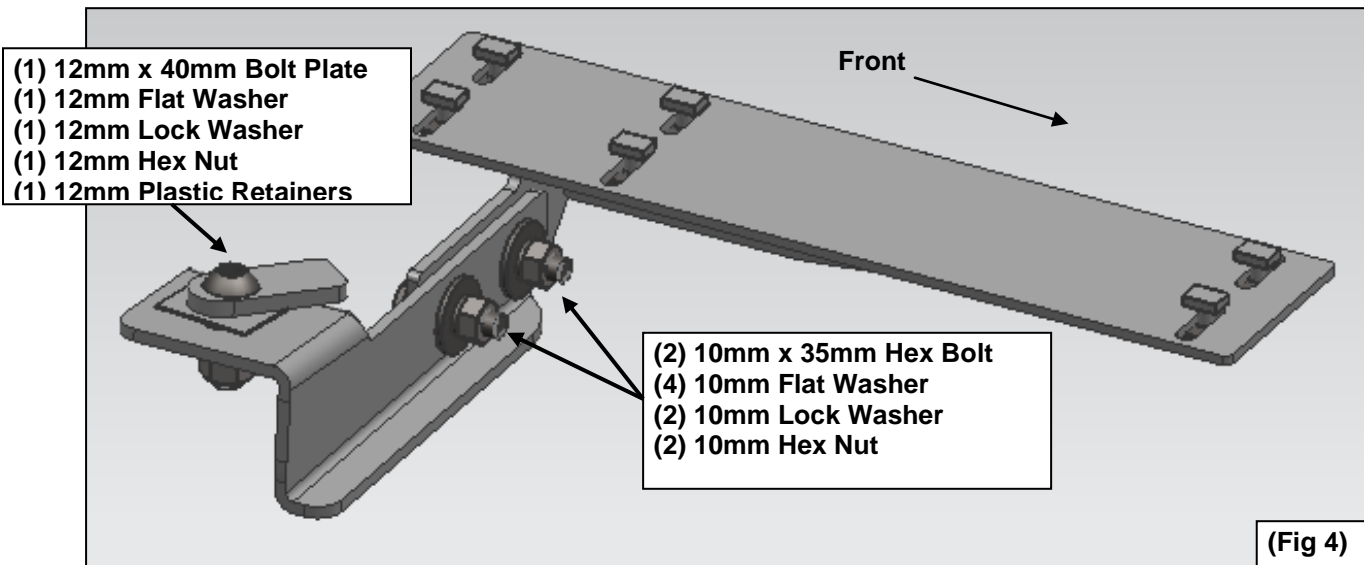

Front

- (1) 12mm x 40mm Bolt Plate
- (1) 12mm Flat Washer
- (1) 12mm Lock Washer
- (1) 12mm Hex Nut
- (1) 12mm Plastic Retainers

- (2) 10mm x 35mm Hex Bolt
- (4) 10mm Flat Washer
- (2) 10mm Lock Washer
- (2) 10mm Hex Nut

(Fig 4)

Driver Side Installation Pictured

Slip 6mm T-bolts into the bottom channel

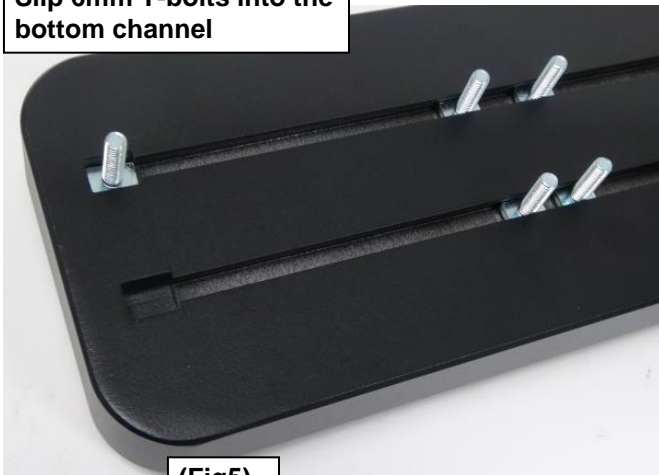

(Fig5)

(6)6mmT-bolts
(6)6mm Flat Washers
(6)6mm Lock nuts

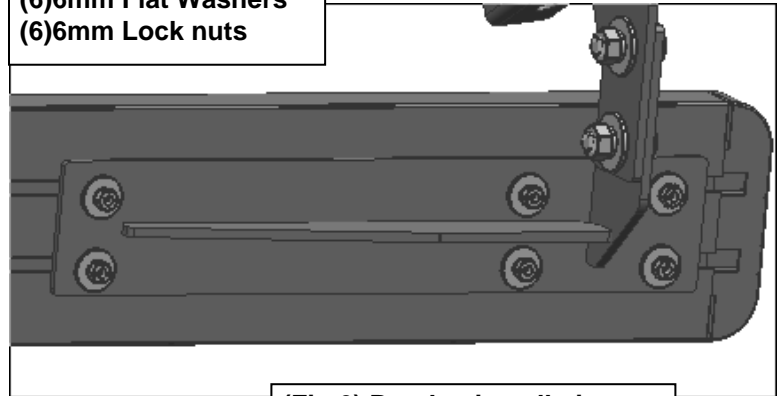

(Fig 6) Bracket installation