

Installation Instructions for IB20EAI1

by APS Auto Parts Specialist Inc.

Application: For 2016-2018 Toyota Rav4 (Excl. 2018 Adventure Trim)
Estimated Time: 1 to 2 hours



Disclaimer: Instructions intended for persons aged 18+ please do not attempt without adult supervision. Instructions are not intended to replace professional installation. Damage from improper installation, misuse or modification to the product voids the manufacturer's warranty.

PARTS LIST:

Item	QTY	Description	Item	QTY	Description
#01	2	Running Board(use for left or right)	#16	2	M10X1.5 - 40mm Carriage Bolts
#02	1	Driver/Left Front Bracket(DFM)	#17	2	10mm Rectangular Washers
#03	1	Passenger/Right Front Bracket(PFM)	#18	10	10mm Plastic Retainers
#04	1	Driver/Left Front Support Bracket(DFS)	#19	2	M10X1.5 - 40mm Hex Bolts
#05	1	Passenger/Right Front Support Bracket(PFS)	#20	2	M10X1.5 - 30mm Hex Bolts
#06	1	Driver/Left Center Mounting Bracket(DCM)	#21	6	10mm x 27mm OD x 3mm Large Flat Washers
#07	1	Passenger Center Mounting Bracket(PCM)	#22	8	10mm x 24mm OD x 2.2mm STD Flat Washers
#08	1	Driver/Left Center Support Bracket(DCS)	#23	2	M10X1.5 Hex Nuts (jam nuts)
#09	1	Passenger/Right Center Support Bracket(PCS)	#24	12	M10X1.5 Nylon Lock Nuts
#10	1	Driver/Left Rear Bracket(DRM)	#25	4	M8X1.25 - 30mm Hex Bolts
#11	1	Passenger/Right Rear Bracket(PRM)	#26	8	M8 Flat Washers
#12	2	Surface Reinforcement Plates(DCS1)	#27	4	M8X1.25 Nylon Lock Nuts
#13	4	M10X1.5 - 62mm Bolt Plates	#28	12	M6X1 - 20mm T-Bolts
#14	2	Locking Plates (for Bolt Plates)	#29	12	M6 Flat Washers
#15	4	M10X1.5m - 50mm T-Bolts	#30	12	M6 Nylon Lock Nuts



PROCEDURE:

- REMOVE CONTENTS FROM BOX. VERIFY ALL PARTS ARE PRESENT. READ FACTORY BODY BOLT REMOVAL INSTRUCTIONS AND INSTALLATION INSTRUCTIONS CAREFULLY BEFORE STARTING INSTALLATION.**
- Starting on the driver side of the vehicle, locate and remove the factory oval rubber plug and (2) round plugs in the bottom of the floor panel located closest to the front tire opening, **(Figure 1 & 2)**. Select (1) M10 x 40mm Carriage Bolt, (1) 10mm Rectangular Washer and (1) 10mm Plastic Retainer, **(Figure 3A)**. Slide the Rectangular Washer onto and over the square shoulder on the Carriage Bolt. Thread the Retainer part way onto the Bolt. **NOTE:** The Plastic Retainer is designed to help hold the Bolt in place during Bracket installation. Insert the Carriage Bolt with Rectangular Washer and Retainer into the inner round hole in the floor panel. Line up the Carriage Bolt with the center of the hole and the Rectangular Washer across the hole. Pull the Carriage Bolt down through the slot in the Washer. Thread the Retainer down tight against the floor panel, **(Figure 3B)**.

3. Select (1) T-Bolt and (1) 10mm Plastic Retainer, **(Figure 4A)**. Insert the T-Bolt up into the oval hole and rotate it 90-degrees so that the block is across the oval hole. Thread the Plastic Retainer onto the T-Bolt and tight against the floor panel, **(Figure 4B)**.
4. Next, select the driver side Front Bracket. Secure the Front Bracket to the T-Bolt first with (1) 10mm x 27mm Large Flat Washer, (1) 10mm Nylon Lock Nut **(Figure 5)**. Snug but do not tighten the hardware at this time.
5. Select the driver side Front Support Bracket. Bolt the Support Bracket to the inner M10 Carriage Bolt with (1) 10mm x 24mm STD Flat Washer and (1) M10 Nylon Lock Nut, **(Figures 5)**. Leave hardware loose. Line up the slot in the Support Bracket with the slot in the Front Mounting Bracket. Bolt the Support Bracket to the front of the Mounting Bracket with (1) M10 x 30mm Hex Bolt, (2) 10mm x 24mm STD Flat Washers, and (1) M10 Nylon Lock Nut **(Figure 5)**. Snug but do not tighten hardware at this time.
6. Move along the side of the vehicle to the center location below where the front and rear doors meet. Locate the 4th and 5th hole in the floor panel from the front wheel opening, **(Figure 6)**. Remove the (2) rubber plugs. Select (2) 10mm Bolt Plates and (2) 10mm Plastic Retainers. Thread (1) Retainer part way onto each Bolt Plate, **(Figure 7A)**. Insert (1) Bolt Plate into the first and second round hole in the floor panel next to the pinch weld, **(Figure 7B)**. **IMPORTANT:** Install the Bolt Plates with the "plates" pointing toward each other, **(Figure 7C)**. Thread the Retainer down tight against the floor panel.
7. Slide (1) Lock Plate over the (2) Bolt Plates. Attach the Lock Plate to the forward Bolt Plate with (1) 10mm x 27mm Large Flat Washer and (1) M10 Nylon Lock Nut, **(Figure 8)**. Hang the Center Support Bracket from the rear Bolt Plate with (1) 10mm x 24mm STD Flat Washer and (1) 10mm Nylon Lock Nut, **(Figures 8—10)**. Do not tighten hardware at this time.
8. Select the Center Mounting Bracket, (1) M10 x 40mm Hex Bolt, (1) 10mm Regular Hex Nut and (1) Reinforcement Plate, **(Figure 9)**. Thread the M10 Hex Nut all the way down the M10 x 40mm Hex Bolt. Insert the Hex Bolt with Nut up and into the welded nut on the tab on the Center Bracket, **(Figure 9)**. **NOTE:** Thread the Bolt in until a few threads are sticking out of the welded nut. **Do not** thread the Hex Bolt all of the way into the welded nut. Bolt the Center Mounting Bracket to the front side of the Center Support Bracket with (2) M8 x 30mm Hex Bolts, (4) M8 Flat Washers and (2) M8 Nylon Lock Nuts, **(Figure 10)**. Leave hardware loose at this time.
9. Place (1) Reinforcement Plate onto the threaded end of the M10 x 40mm Hex Bolt, **(Figure 9)**. Continue to thread the Hex Bolt in until the Reinforcement Plate is close to but not touching the bottom of the body panel, **(Figure 10)**. Snug but do not tighten the 8mm mounting hardware. **IMPORTANT:** Do not tighten the hardware on the Center Brackets until the final Steps, **(see Step 16)**.
10. Move along the vehicle to the rear mounting location, **(Figure 11)**. Remove the oval rubber plug. Select (1) T-Bolt and (1) 10mm Plastic Retainer, **(Figure 12A)**. Insert the T-Bolt up into the oval hole and rotate 90-degrees so that the block is across the oval hole. Thread the Plastic Retainer onto the T-Bolt and tight against the floor panel as described in **Step 3**, **(Figures 4A & 12B)**.
11. Select the driver side Rear Mounting Bracket. Hang the Rear Bracket from the T-Bolt with (1) 10mm x 27mm Large Flat Washer and (1) M10 Nylon Lock Nut, **(Figure 13)**. Snug but do not tighten the M10 Lock Nut on the rear Bracket.
12. Select a Running Board. Slip (6)M6 T-bolts into each bottom channel **(Figure 14a)**. Carefully position the Running Board onto the (3) Mounting Brackets. **IMPORTANT:** Do not slide, (front to back), the Running Board on the Brackets or damage to the finish may result. Attach the Running Board to each Mounting Brackets with (2) M6 T-bolts, (2)M6 flat washers and (2)M6 nylon lock nuts **(Figures 14b)**. Do not tighten at this time.
13. Check to see if the Running Board is level to the bottom of the car, front to rear, not level to the ground. Adjust the Brackets as necessary to line up the Running Board with the side of the vehicle. Move to the rear Bracket and once aligned, tighten the 10mm Lock Nut on the T-Bolt, **(Figure 13)**.
14. Next, move to the front Bracket. Tighten the T-Bolt and Carriage Bolt hardware only, **(Figures 3A & 4A)**. Adjust the height of the front Bracket as necessary. Once properly adjusted, tighten the 10mm Hex Bolt securing the Support Bracket to the front Mounting Bracket, **(Figure 5)**.

15. With the front and rear Brackets fully tightened to the vehicle, move to the Center Bracket. Fully tighten the 10mm Lock Nut securing the Support Bracket to the Bolt Plate. Gently push the Mounting Bracket up against and level to the bottom of the Running Board. Tighten the (2) 8mm Hex Bolts. Slowly tighten the 10mm x 40mm Hex Adjustment Bolt until the Reinforcement Plate is snug against the bottom of the body panel. Turn the Hex Bolt 1/2 to 1 full turn tighter to add preload. Tighten the 10mm Hex Nut to lock the 10mm x 40mm Hex Bolt in the Bracket, (**Figure 15**).
16. Level and adjust Running Board properly and tighten all hardware. **NOTE: Torque all M6 nylon lock nuts to 7 lb-ft.**
17. Repeat **Steps 2 –16** for passenger side Running Board installation.
18. Do periodic inspections to the installation to make sure that all hardware is secure and tight

To protect your investment, wax this product after installing. Regular waxing is recommended to add a protective layer over the finish. Do not use any type of polish or wax that may contain abrasives that could damage the finish.

For Polished Finishes: Aluminum polish may be used to polish small scratches and scuffs on the finish. Mild soap may be used also to clean the Running Board.

For Black Finishes: Mild soap may be used to clean the Running Board.

Driver Side Installation Pictured

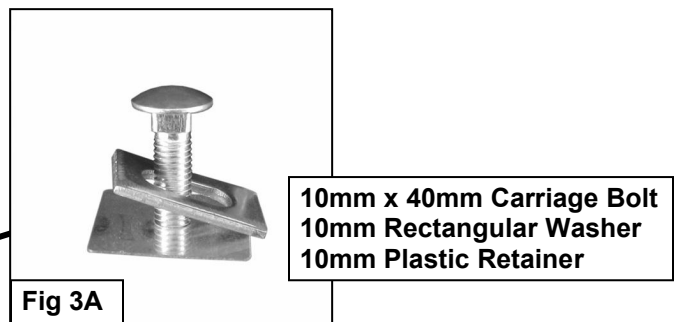
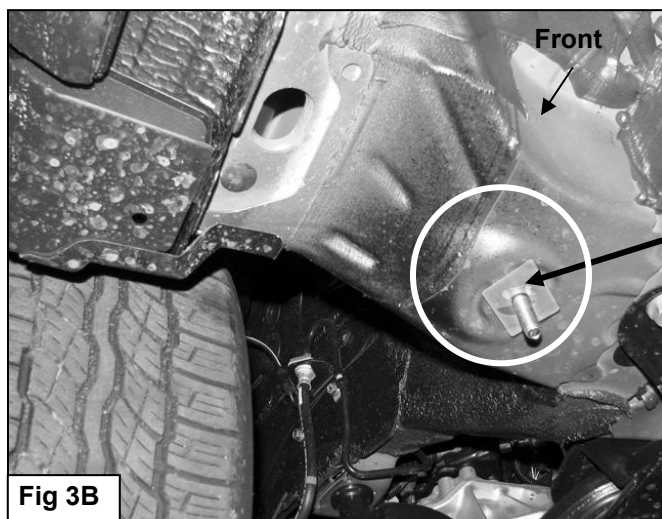
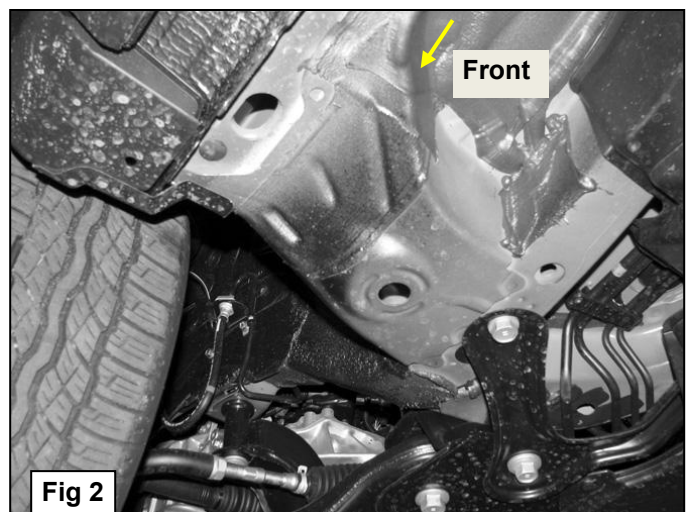
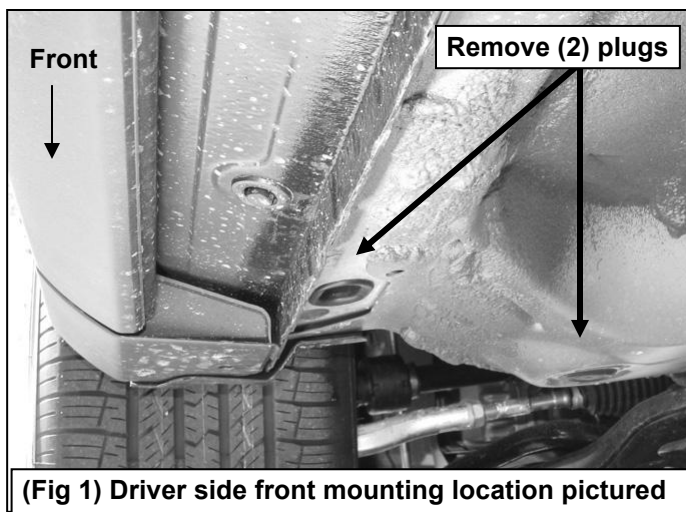

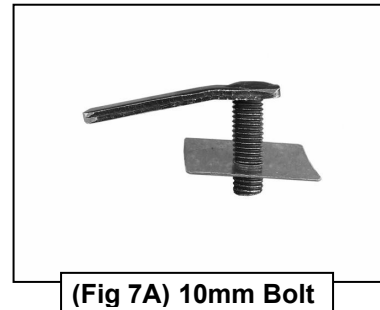
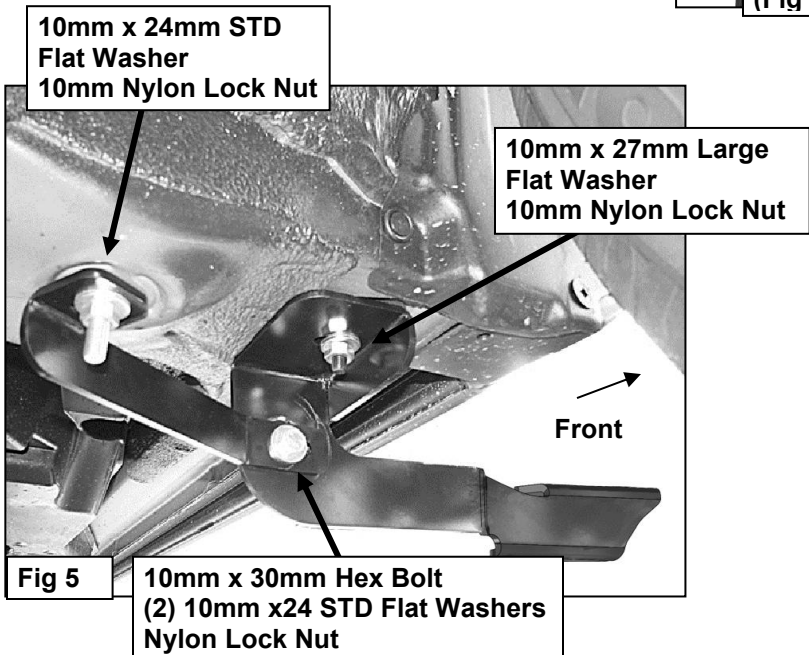
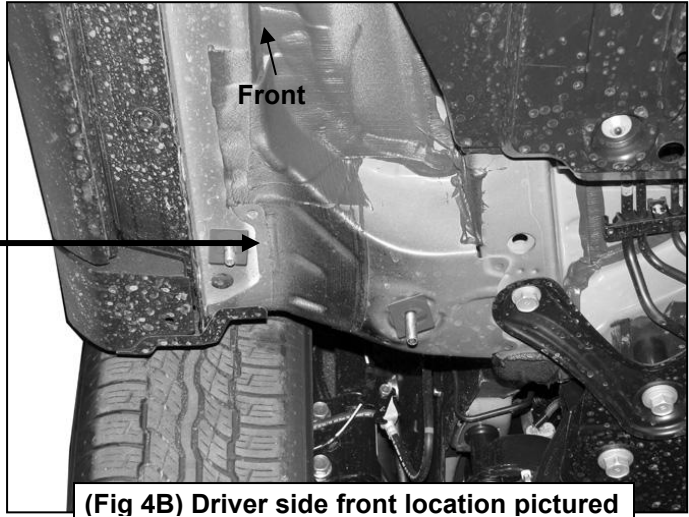

From the front fender opening, locate the 4th and 5th rubber plugs along the floor panel

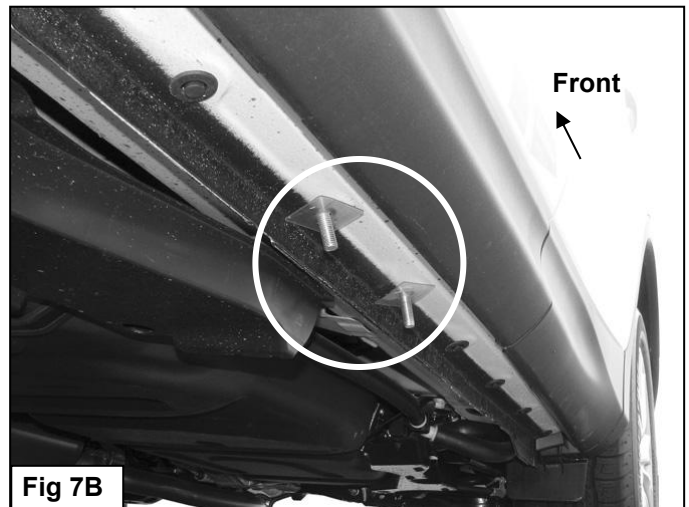
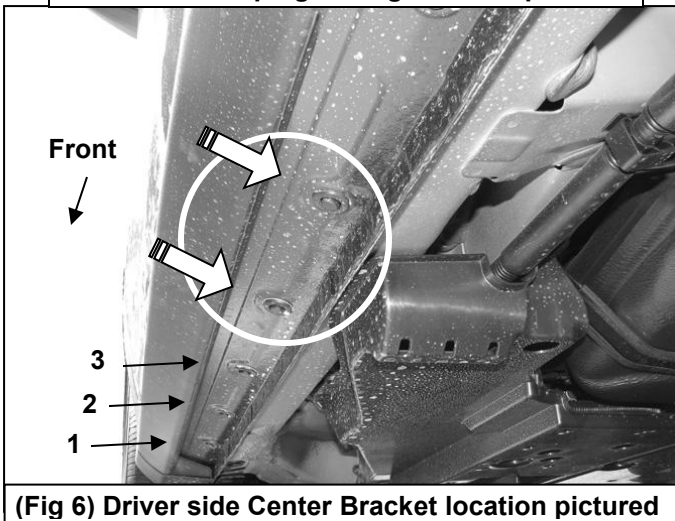

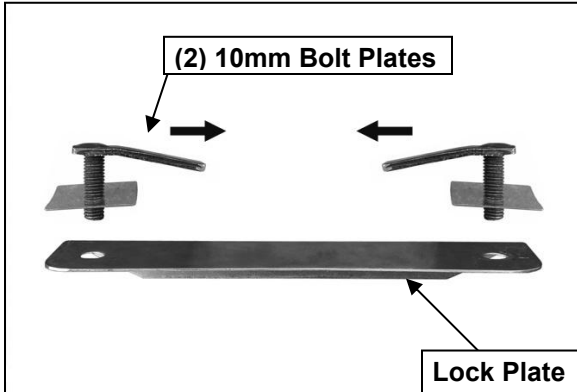

(Fig 7C) Install Bolt Plates with Plates pointing towards each other

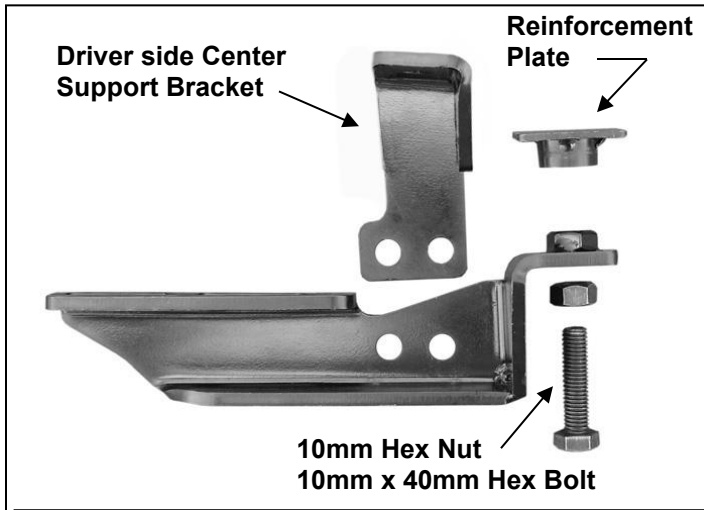
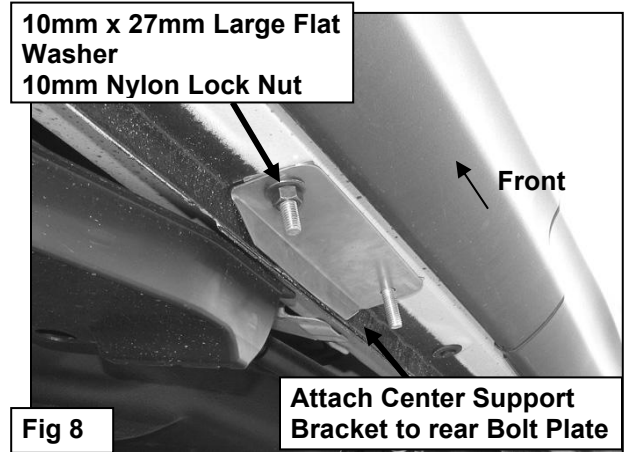

(Fig 9) Driver side Center Bracket assembly pictured

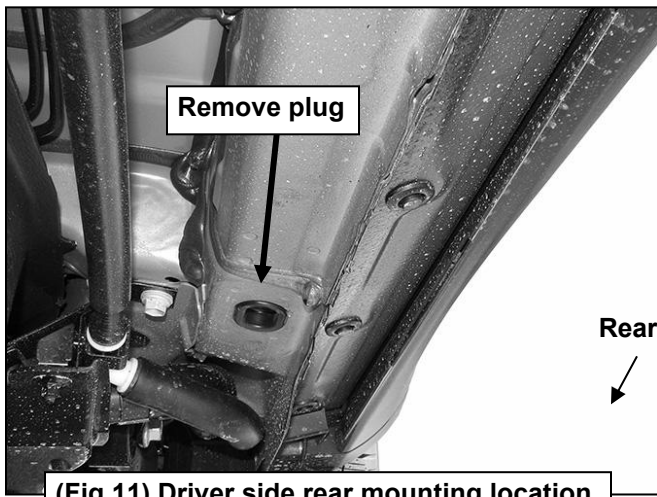
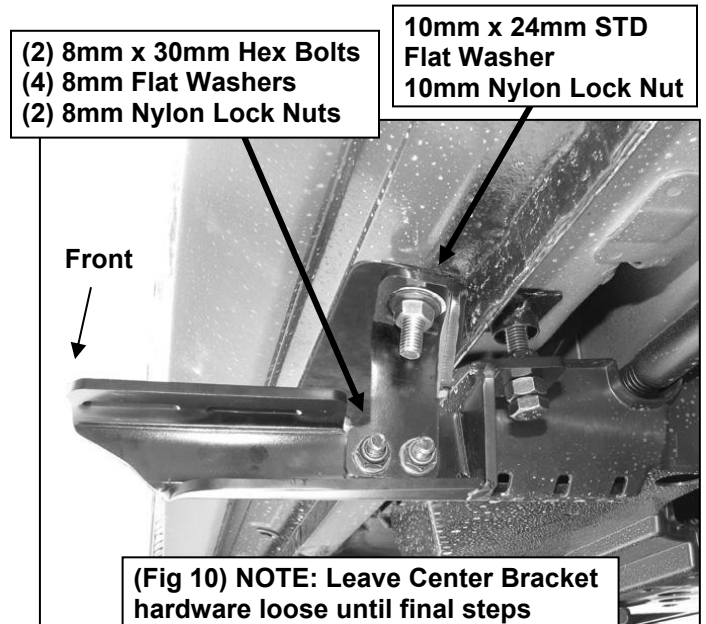

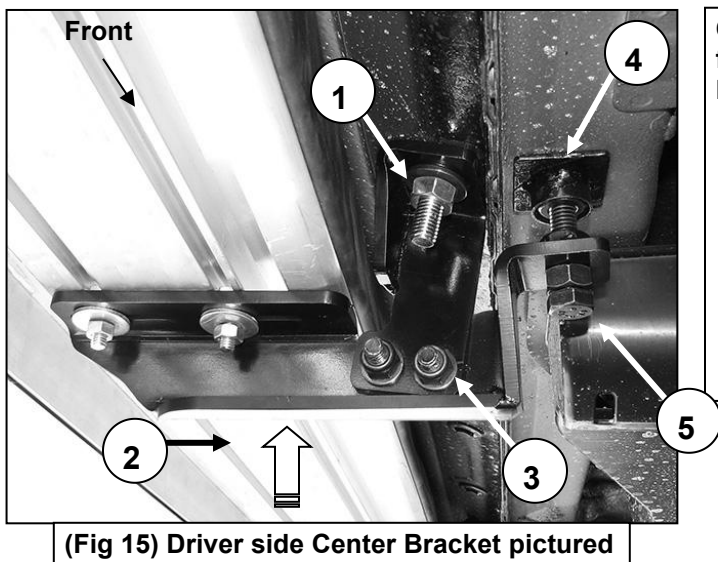
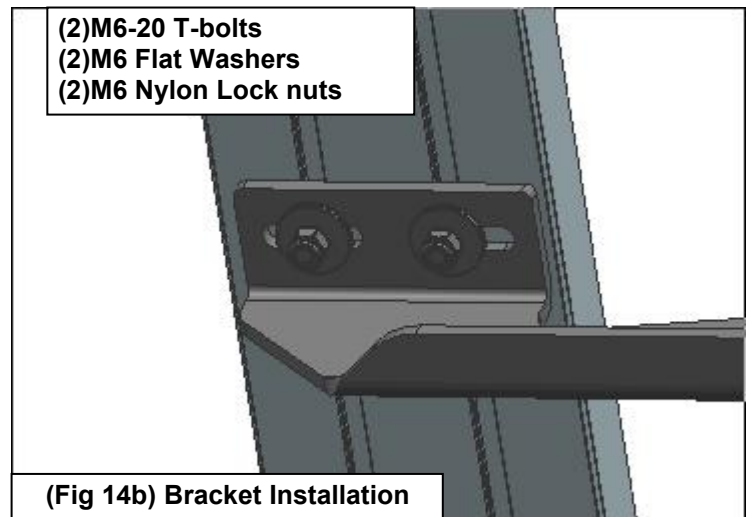
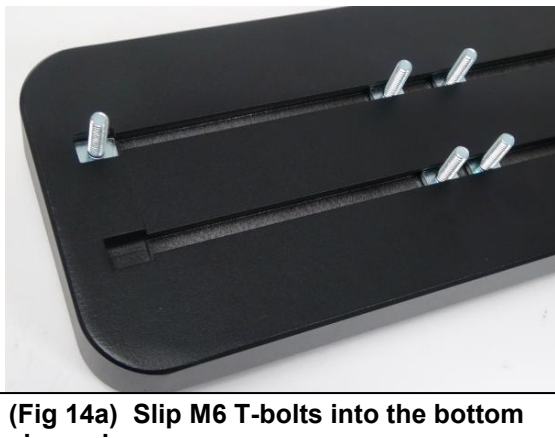
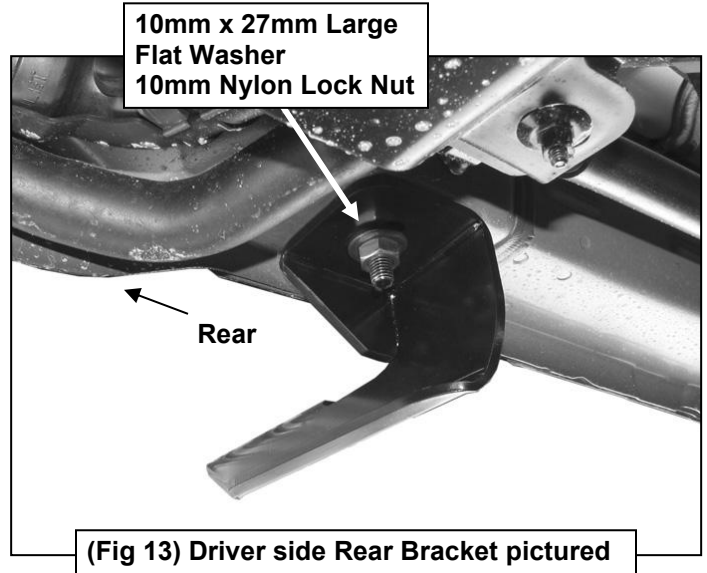
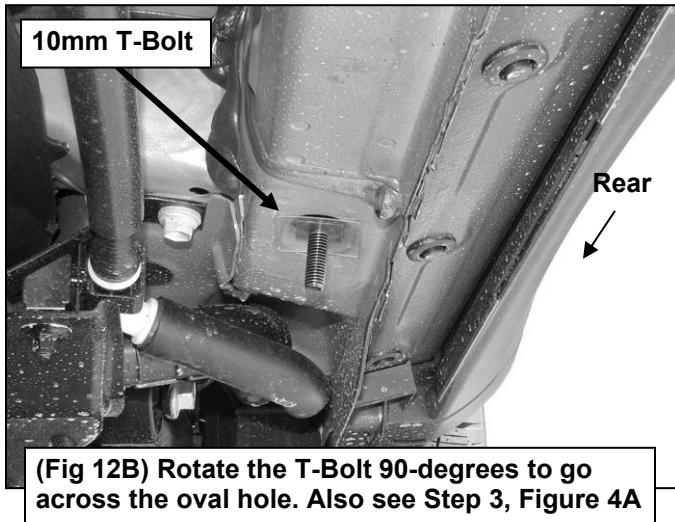

Once the Running Board has been aligned and the front and rear brackets fully tightened, adjust the height of the Center Bracket:

1. Tighten the 10mm Bolt Plate hardware
2. Hold the Bracket level and against the bottom of the Running Board
3. Tighten the (2) 8mm Hex Bolts
4. Tighten the 10mm x 40mm Hex Bolt until the Reinforcement Plate is snug up against the floor panel
5. Turn Hex Bolt 1/2 to 1 full turn and tighten jam nut to lock adjustment. Readjust as necessary