

(6",5",4")RUNNING BOARD  
For 2008-2016 Toyota Sequoia

# Installation Instructions for IB20DBC1

by APS Auto Parts Specialist Inc.

Application: For 2008-2016 Toyota Sequoia

Estimated Time: 1 to 2 hours



Disclaimer: Instructions intended for persons aged 18+ please do not attempt without adult supervision. Instructions are not intended to replace professional installation. Damage from improper installation, misuse or modification to the product voids the manufacturer's warranty.

**PARTS LIST:**

Item	QTY	Description	Item	QTY	Description
#01	1	Driver/Left Sidebar	#08	1	Passenger Rear Mounting Brackets (PRM)
#02	1	Passenger/Right Sidebar	#09	12	M8X1.25-30 Hex Bolts
#03	1	Driver/Left Front Mounting Brackets (DFM)	#10	12	M8 Flat Washers
#04	1	Passenger/Right Front Mounting Brackets (PFM)	#11	12	M8 Lock Washer
#05	1	Driver Center Mounting Brackets (DCM)	#12	24	M6 T-Bolts
#06	1	Passenger Center Mounting Brackets (PCM)	#13	24	M6 Flat Washers
#07	1	Driver/Left Rear Mounting Brackets (DRM)	#14	24	M6 Nylon Lock Nuts



**PROCEDURE:**

**REMOVE CONTENTS FROM BOX. VERIFY ALL PARTS ARE PRESENT. READ INSTRUCTIONS CAREFULLY.**

1. Starting on the driver side, front of tie vehicle, locate the two factory threaded holes in the side panel by the front flare in the body. Partially attach the driver side front Mounting Bracket to the vehicle using the included (2)M8X30 Hex Head Bolts, (2)M8 Lock Washers and (2)M8 Flat Washers (**Figure 1**).
2. Locate the two factory threaded holes in side panel by the rear flare on the body and partially attach the driver side rear Mounting Bracket to the vehicle using the same hardware listed in Step 2, (**Figure 2**).
3. Position the driver Sidebar onto the front and rear Mounting Bracket and loosely attach it using the included (4)M8X30 Hex Head Bolts, (4)M8 Lock Washers and (4)M8 Flat Washers (**Figure 1&2**).
4. There are two sets of holes in the side panel between the installed Mounting Brackets, one set by the front Mounting Bracket and the other one by the rear Mounting Bracket. To determine which holes you will be using, position the center Mounting Bracket over the center inserts in the Sidebar and line up the opposite end to the mounting location on the side panel. Partially install the center Mounting Bracket to the vehicle and Sidebar using the included (4)M8X30 Hex Head Bolts, (4)M8 Lock Washers and (4)M8 Flat Washers, (**Figure 3**).
5. Select the Running Board. Slip (12) M6 T-Bolts into each bottom channel (**Figure 4**). Carefully position the Running Board onto the (3) Mounting Brackets. **IMPORTANT:** Do not slide the Running Board on the Brackets or damage to the finish may result. Attach the Running Board to the Mounting Brackets with (4) M6 T-bolts, (4)M6 flat washers and (4)M6 Nylon lock nuts, (**Figure 5**). Do not tighten hardware.
6. Level and adjust the Running Board and fully tighten all hardware.
7. Repeat **Steps 1—6** for other side Running Board installation.
8. Do periodic inspections to the installation to make sure that all hardware is secure and tight.

**To protect your investment**, wax this product after installing. Regular waxing is recommended to add a protective layer over the finish. Do not use any type of polish or wax that may contain abrasives that could damage the finish.

**For Polished Finishes:** Aluminum polish may be used to polish small scratches and scuffs on the finish. Mild soap may be used also to clean the Running Board.  
**For Black Finishes:** Mild soap may be used to clean the Running Board.

### Driver Side Installation Pictured

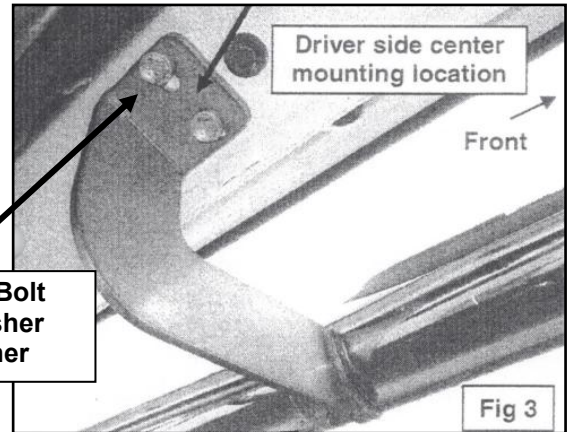
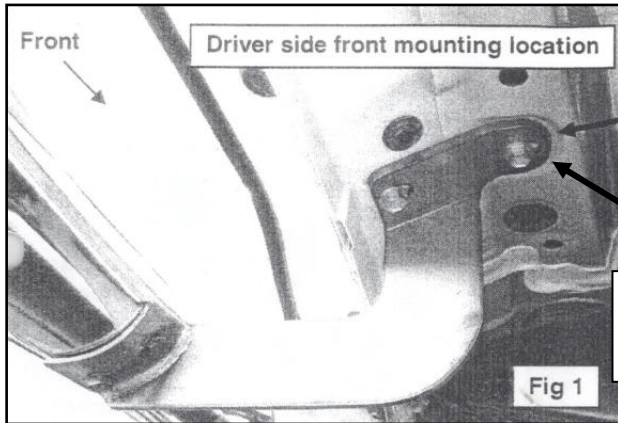

M8 x 30 Hex Bolt  
M8 Lock Washer  
M8 Flat Washer

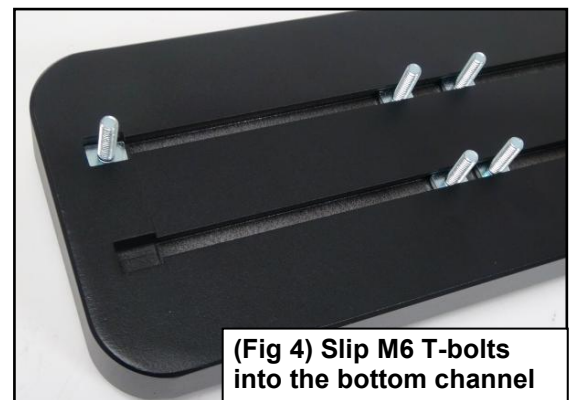
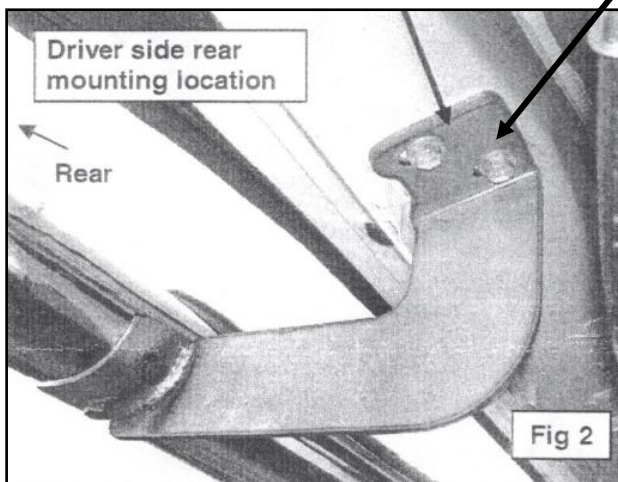

(4)M6 T-bolts  
(4)M6 Flat Washers  
(4)M6 Nylon Lock nuts

