

# Installation Instructions for IB14EBF9

by APS Auto Parts Specialist Inc.

**Application:** For 2014-2018 Nissan Rogue (Excl. 14 Rogue Select & Sport)  
Estimated Time: 1 to 2 hours



Disclaimer: Instructions intended for persons aged 18+ please do not attempt without adult supervision. Instructions are not intended to replace professional installation. Damage from improper installation, misuse or modification to the product voids the manufacturer's warranty.

**PARTS LIST:**

Item	QTY	Description	Item	QTY	Description
#01	2	Running Board(use for left or right)	#11	8	8mm x 24mm OD x 2mm Flat Washers
#02	2	Driver/Left Front/Center Brackets(DFM/DCM)	#12	8	M8 Lock Washers
#03	2	Passenger/Right Front/Center Brackets(PFM/PCM)	#13	4	M8X1.25 Hex Nuts
#04	1	Driver/Left Rear Bracket(DRM)	#14	12	M6X1.0-20 T-Bolts
#05	1	Passenger/Right Rear Bracket(PRM)	#15	8	M6X1.0-25 Hex Bolts
#06	2	M8X1.25 - 30mm Bent Tab Bolt Plates	#16	12	6mm x 22mm OD x 2mm Flat Washers
#07	2	M8X1.25 - 40mm Bolt Plates	#17	16	6mm x 12mm x 1.6mm Flat Washers
#08	1	M8X1.25mm Threaded Insert	#18	8	M6 Lock Washers
#09	1	Threaded Insert Tool	#19	8	M6 Hex Nuts
#10	4	M8X1.25 - 25mm Hex Bolts	#20	12	M6 Nylon Lock Nuts



**DRM**

**DFM/DCM**

**PFM/PCM**

**PRM**

**PROCEDURE:**

- 1. REMOVE CONTENTS FROM BOX. VERIFY ALL PARTS ARE PRESENT. READ FACTORY BODY BOLT REMOVAL INSTRUCTIONS AND INSTALLATION INSTRUCTIONS CAREFULLY BEFORE STARTING INSTALLATION.**
2. Start installation on the passenger side of the vehicle. Remove the plastic rocker panel cover running from wheel opening to wheel opening, **(Figure 1)**. **NOTE:** Removal of the rocker panel cover is not mandatory but it is highly recommended.
3. Locate the (2) factory hex bolts in the bottom of the inner frame channel, **(Figure 2)**. Remove only the rear hex bolt if equipped, **(Figure 2)**. Do not remove the front hex bolt.
4. Select (1) passenger side front/center Mounting Bracket, **(Figure 3)**. **NOTE:** When properly installed, the mounting cradles on all (3) Brackets will point toward the rear of the vehicle.

5. Attach the inner end of the Bracket to the frame channel with (1) M8 Hex Bolt, (1) M8 Lock Washer and (1) M8 Flat Washer, **(Figure 4)**. Line up the tab on the Bracket with the outside of the pinch weld. Use a clamp to temporarily attach the tab on the Bracket to the pinch weld.
6. Move toward the rear of the vehicle. Locate the factory holes in the bottom of the floor panel behind the jack point on the pinch weld directly in front of the rear suspension mount, **(Figure 5)**. Select (1) 8mm Bolt Plate, **(Figure 6A)**. Insert the Bolt Plate into the round hole in the inner floor panel, **(Figure 6C)**. Select (1) 8mm Bolt Plate with Bent Tab, **(Figure 6B)**. Insert the Bolt Plate into the oval hole. Feed the threaded end of the Bolt Plate into and out of the smaller outer hole. **NOTE:** Hold the passenger side Rear Bracket up in place to help determine the correct mounting holes for the Bracket.
7. Select the passenger side Rear Bracket, **(Figure 7)**. Attach the Bracket to the (2) Bolt Plates with (2) M8 Flat Washers, (2) M8 Lock Washers and (2) M8 Hex Nuts, **(Figure 8)**. Do not tighten.
8. Carefully unwrap and select the passenger side Running Board. Select (6) M6 T-Bolts. From the front, insert (3) T-Bolts into each channel in the bottom of the Running Board, **(Figure 9)**. Slide the T-Bolts forward, to the center and to the back to line up with the front and back Mounting Brackets, **(Figures 8 & 10)**. Hold the Running Board up to the vehicle at a slight angle and push it into position onto the Brackets. **NOTE:** It may be necessary to loosen the front and rear Brackets to fit the Running Board between the body and the Brackets.
9. Attach the Running Board to the Mounting Brackets with the included (4) 6mm x 22mm Large Flat Washers, (4) M6 Lock Washers and (4) M6 Hex Nuts, **(Figures 8 & 10)**. Center (2) T-Bolts will not be used at this time. Do not tighten hardware.
10. Line up the Running Board with the front and rear of the vehicle. Once properly aligned, tighten the hardware and clamp attaching the front and rear mounting Brackets to the vehicle only.
11. Move to the center of the vehicle. Locate the holes in the bottom of the inner frame channel, **(Figure 1)**. Locate the 6th hole back from the front bracket mounting location. **IMPORTANT:** Mark the correct mounting hole before moving to **Step 12**, **(Figure 11)**.
12. Select (1) M8 Hex Bolt, (1) M8 Flat Washer, (1) M8 Insert Tool and (1) M8 Threaded Insert. Assemble the tool as pictured in **(Figure 12)**. Hold the Tool assembly and push the threaded Insert into the correct hole in the frame channel identified in **Step 11**, **(Figures 1 & 11)**. **IMPORTANT:** Threaded Insert cannot be removed once installed. Verify that Insert is in the correct hole in the frame channel before proceeding.
13. Hold the Insert in place by firmly grasping the handle on the Tool. Turn the Hex Bolt, (tighten), with wrench to expand the Insert in the hole in the frame channel, **(Figures 13A & 13B)**. Once the Insert is fully compressed/expanded, remove the Hex Bolt and Tool from the Insert. **WARNING:** Do not over-tighten the Insert or damage to the part or Insert may result.
14. Bolt the inner end of the center Bracket to the Insert with (1) M8 Hex Bolt, (1) M8 Lock Washer and (1) M8 Flat Washer, **(Figure 14)**. Use a clamp to temporarily attach the outer end of the Bracket to the pinch weld to help hold up the Bracket as described in **Step 5**, **(Figure 14)**.
15. Level and adjust the Running Board to the vehicle. Once properly adjusted, mark the location of the front, **(Figure 15)**, and center, **(Figure 16)**, mounting tabs onto the outside of the pinch weld. **IMPORTANT:** Adjust the Running Board height, (push upward), so that when level, the holes in the mounting tabs are not too close to the bottom edge of the pinch weld.
16. Remove the Running Board and loosen or remove the front and center Brackets. Use a 1/4" drill bit to drill out the (4) holes in the pinch weld for the front and center Brackets. **IMPORTANT!** Any cutting or drilling tool may break or shatter. Government regulations require safety glasses & equipment at all times when cutting or drilling.
17. Reinstall the front Bracket as previously described. Attach the outer end of the Bracket to the outside of the pinch weld with (2) M6 Hex Bolts, (4) 6mm x 12mm Small Flat Washers, (2) M6 Lock Washers and (2) M6 Hex Nuts, **(Figure 17)**.
18. Repeat **Step 17** to reinstall the center Bracket, **(Figure 18)**.
19. Hold the plastic rocker panel cover up in position over the mounting tabs on the front and center Brackets, **(Figure 19)**. Apply removable tape, (masking tape for example), to the plastic cover. Mark the location of the mounting tabs onto the tape, not the cover. Use a sharp knife or hacksaw blade to

carefully cut out a section of the cover to clear each mounting tab. **IMPORTANT:** Trim as little as possible to clear the mounting tab and hardware. **NOTE:** Primarily, the cover will need to be trimmed to clear the tab on the center mounting Bracket, (**Figure 19**). The front of the cover may only need minor trimming to clear the tab, (**Figure 17**). Reinstall the rocker cover with the factory hardware once properly cleared.

20. Reinstall the Running Board as previously described. Attach the Running Board to the center Bracket with (2) M6 Flat Washers and (2) M6 Nylon Lock Nuts, (**Figure 18**)
21. Adjust the Running Board properly and tighten all hardware at this time. **NOTE: Torque all M6 nylon lock nuts to 7 lb-ft.**
22. Repeat **Steps 2—21** for driver side Running Board installation.
23. Do periodic inspections to the installation to make sure that all hardware is secure and tight

**To protect your investment**, wax this product after installing. Regular waxing is recommended to add a protective layer over the finish. Do not use any type of polish or wax that may contain abrasives that could damage the finish.

**For Polished Finishes:** Aluminum polish may be used to polish small scratches and scuffs on the finish. Mild soap may be used also to clean the Running Board.

**For Black Finishes:** Mild soap may be used to clean the Running Board.

### Passenger Side Installation Pictured

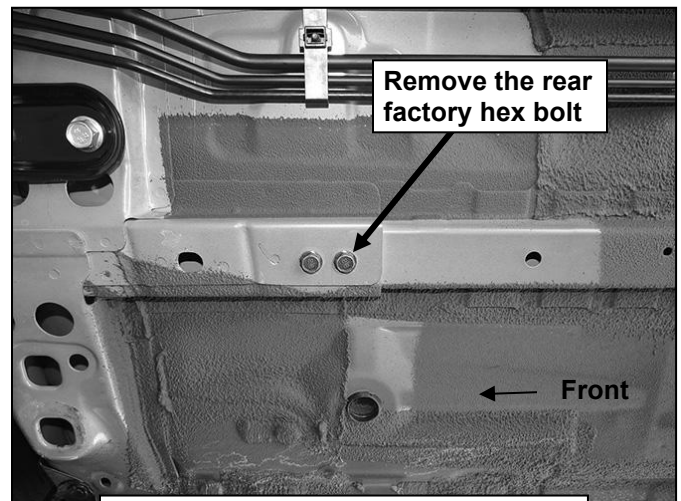
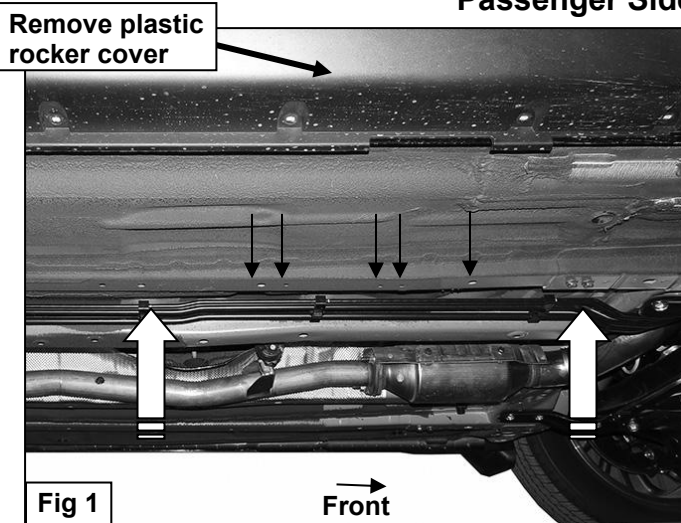

(Fig 2) Passenger side front inner location pictured from below vehicle

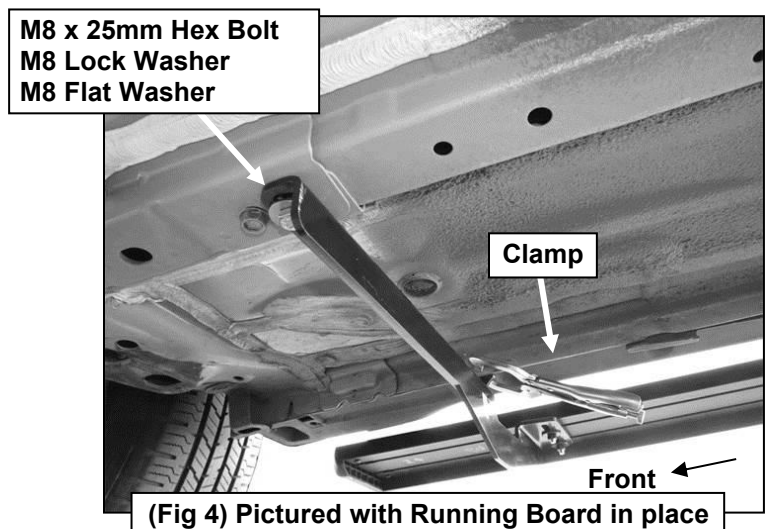
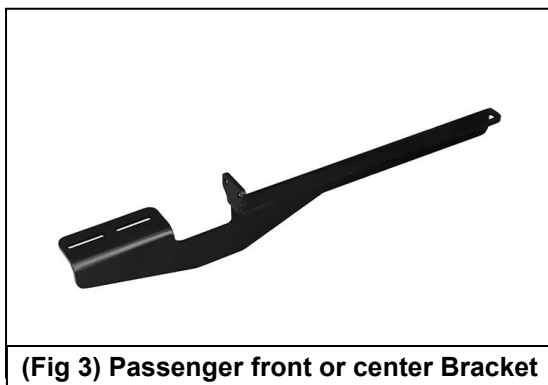

### Passenger Side Installation Pictured

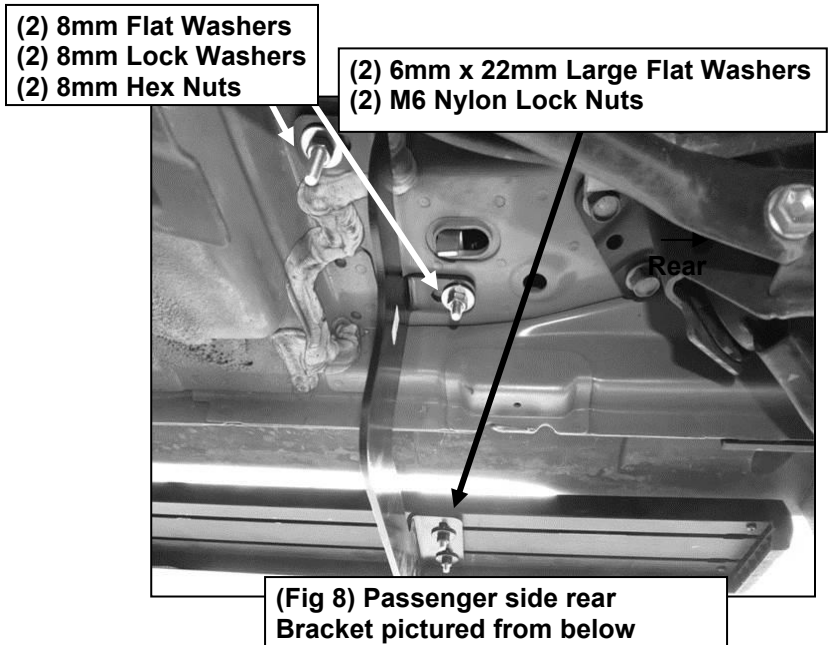
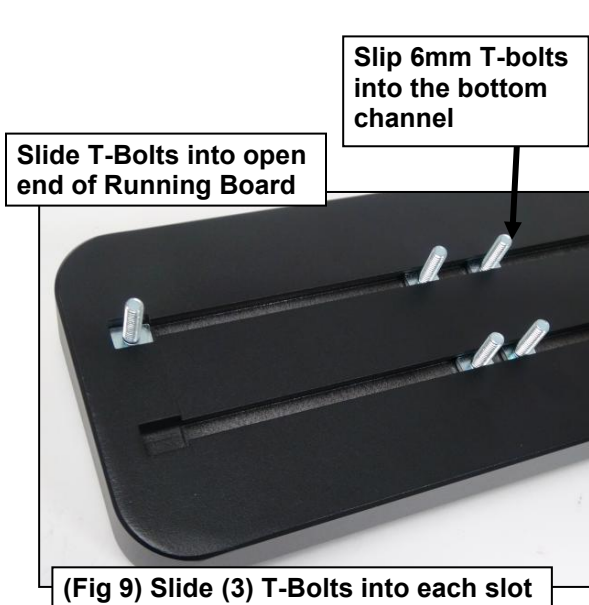
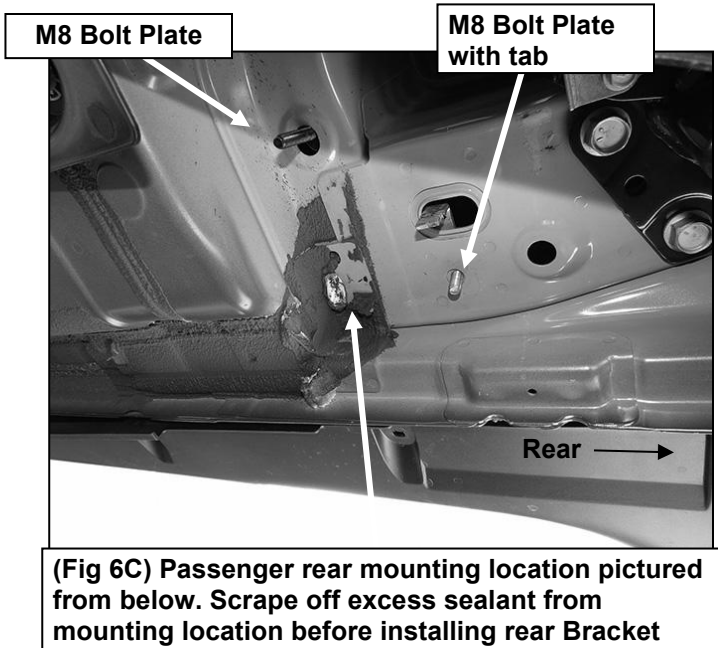
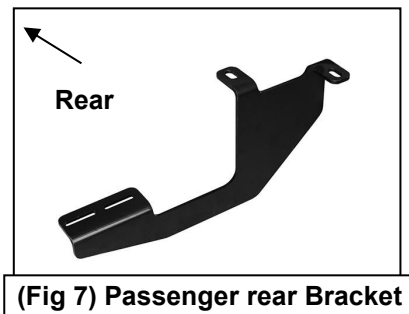
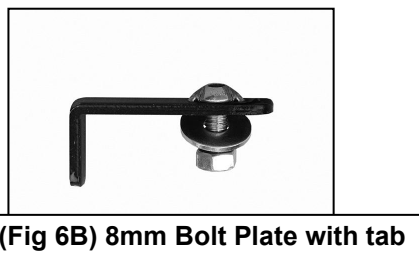
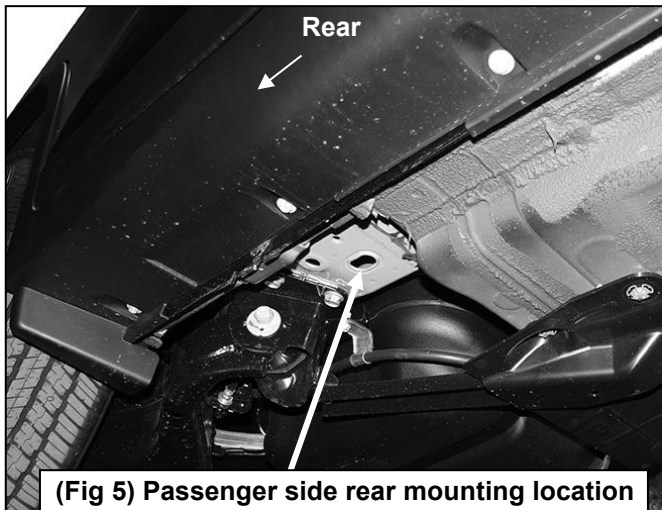

### Passenger Side Installation Pictured

8mm x 25mm Hex Bolt  
8mm Lock Washer  
8mm Flat Washer

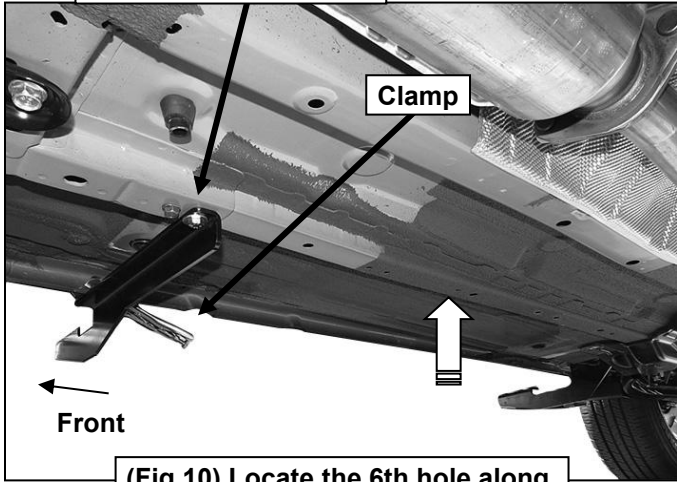

(Fig 10) Locate the 6th hole along the bottom of the frame channel

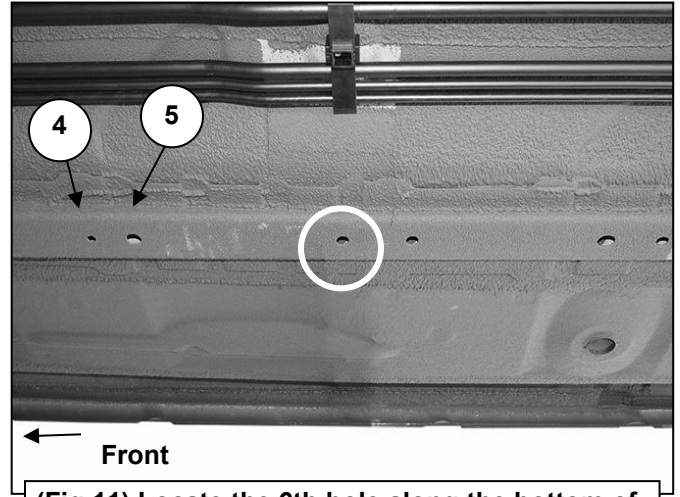

(Fig 11) Locate the 6th hole along the bottom of the frame channel. Also refer to Figure 1

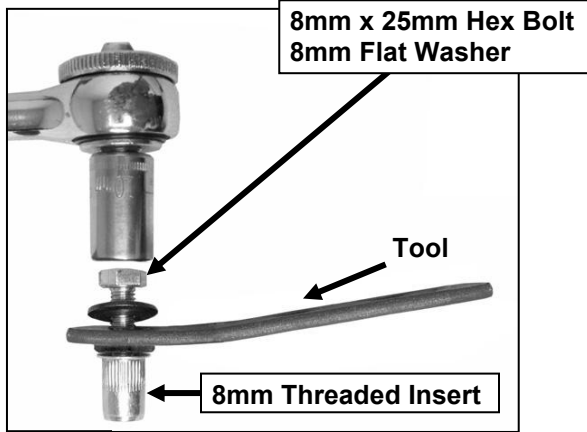

Fig 12

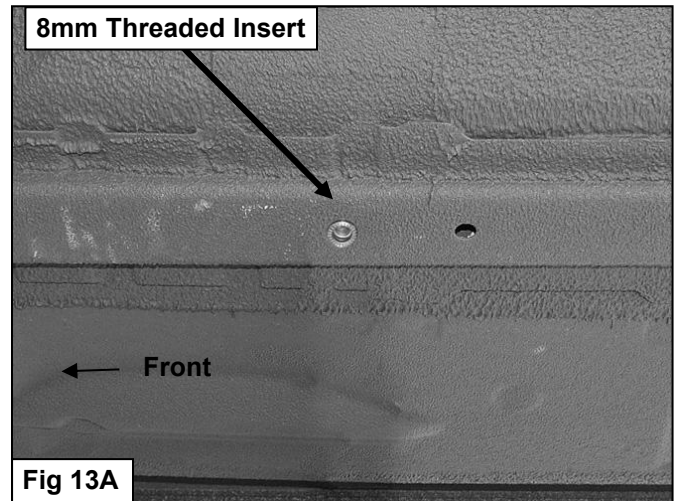
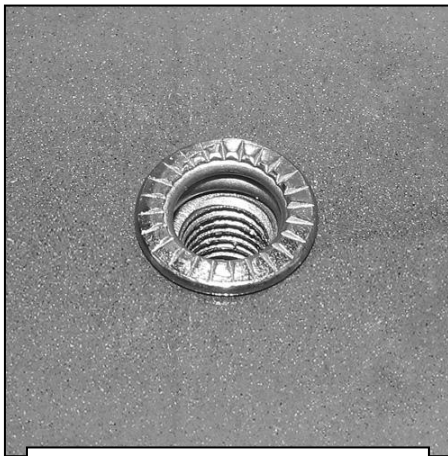
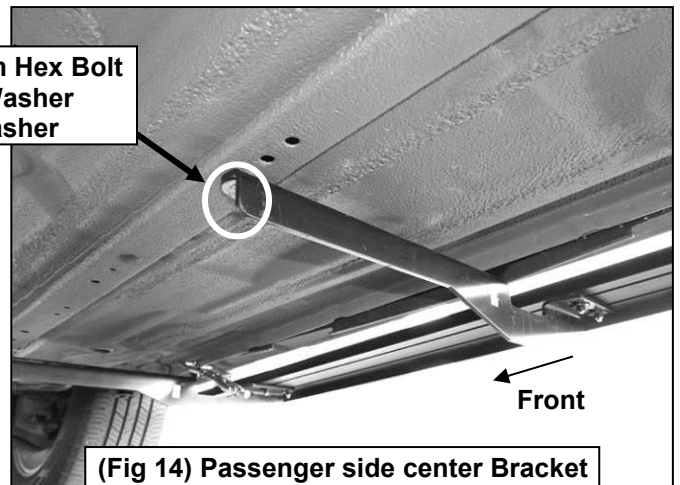

Fig 13A



(Fig 13B) Insert fully installed

8mm x 25mm Hex Bolt  
8mm Lock Washer  
8mm Flat Washer



(Fig 14) Passenger side center Bracket

### Passenger Side Installation Pictured

