

# Installation Instructions for IB14EBB8

by APS Auto Parts Specialist Inc.

Application: For 2005-2015 Nissan Xterra  
Estimated Time: 1 to 2 hours



Disclaimer: Instructions intended for persons aged 18+ please do not attempt without adult supervision. Instructions are not intended to replace professional installation. Damage from improper installation, misuse or modification to the product voids the manufacturer's warranty.

## PARTS LIST:

Item	QTY	Description	Item	QTY	Description
#01	2	Running Board(use for left or right)	#05	12	M8 Flat Washers
#02	3	Driver/Left Mounting Brackets(DFM/DCM/DRM)	#06	12	M6 x 20mm T-Bolts
#03	3	Passenger/Right Mounting Brackets(PFM/PCM/PRM)	#07	12	M6 Flat Washers
#04	12	M8 Lock Nuts	#08	12	M6 Nylon Lock Nuts

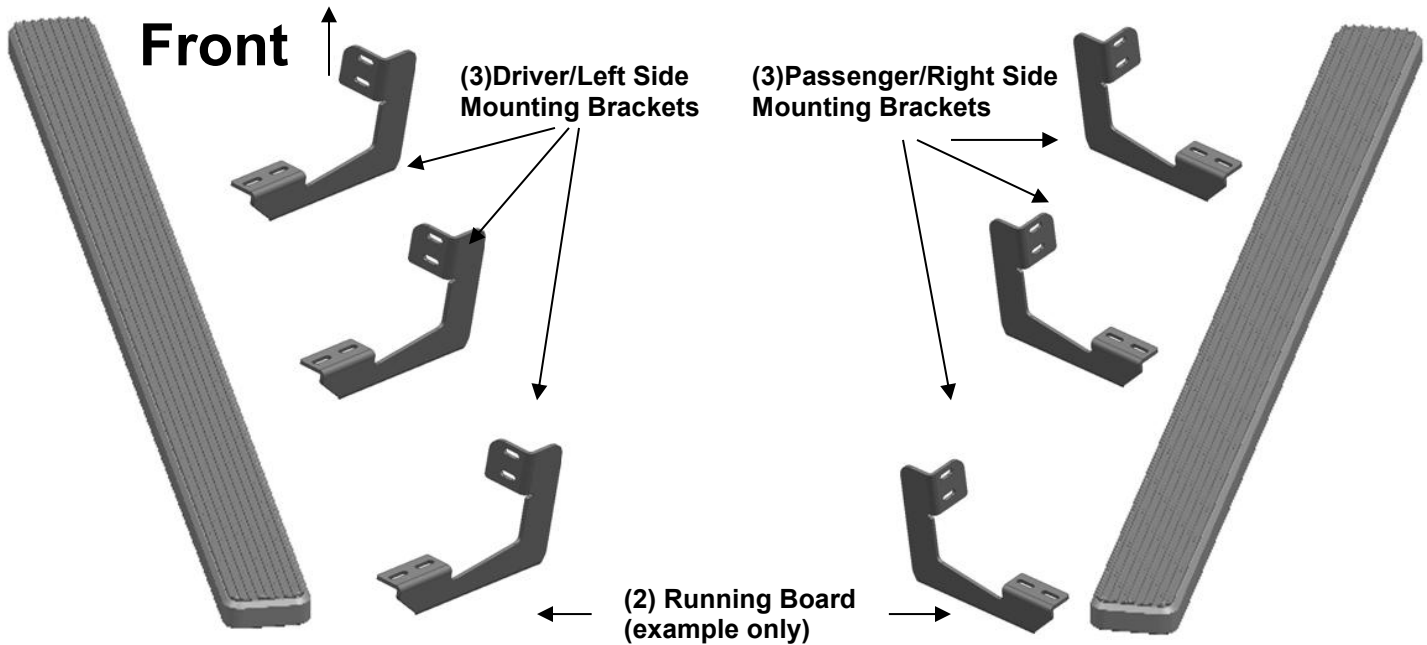

## PROCEDURE:

1. REMOVE CONTENTS FROM BOX. VERIFY ALL PARTS ARE PRESENT. READ INSTRUCTIONS CAREFULLY BEFORE STARTING INSTALLATION.
2. Start installation at the front of the driver side of the vehicle and locate the factory threaded studs located on the side of the inner body panel, **(Figure 1)**.
3. Select (1) driver side Mounting Bracket. Attach the Bracket to two studs with (2) 8mm x 24mm Flat Washer and (2) 8mm Nylon Lock Nut. **(Figures 2)**. Do not tighten hardware at this time.
4. Repeat **Steps 2-3** to installed center and rear position brackets.
5. Once all three Mounting Brackets are partially installed, Select the Running Board. Slip (6) 6mm T-Bolts into each bottom channel **(Figure 3)**. Carefully position the Running Board onto the Mounting Brackets. Attach the Running Board to the Mounting Brackets with (2) M6 T-bolts, (2) M6 flat washers and (2) M6 nylon lock nuts, **(Figure 4)**. Do not tighten hardware at this time.
6. Level and adjust the Running Board and tighten all hardware at this time.
7. Repeat **Steps 2—6** for passenger Running Board installation.
8. Do periodic inspections of the installation to make sure that all hardware is secure and tight.

**To protect your investment**, wax this product after installing. Regular waxing is recommended to add a protective layer over the finish. Do not use any type of polish or wax that may contain abrasives that could damage the finish.

**For Polished Finishes:** Aluminum polish may be used to polish small scratches and scuffs on the finish. Mild soap may be used also to clean the Running Board.

**For Black Finishes:** Mild soap may be used to clean the Running Board.

### Driver Side Installation Pictured

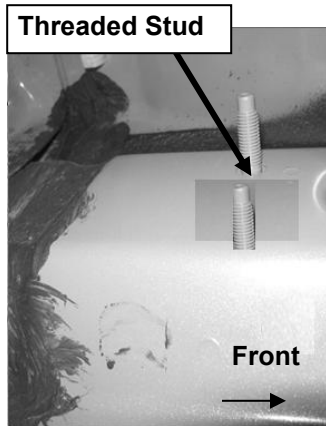

(Fig 1)

- (2)8mm Lock Nuts
- (2)8mm x 24mm Flat Washers

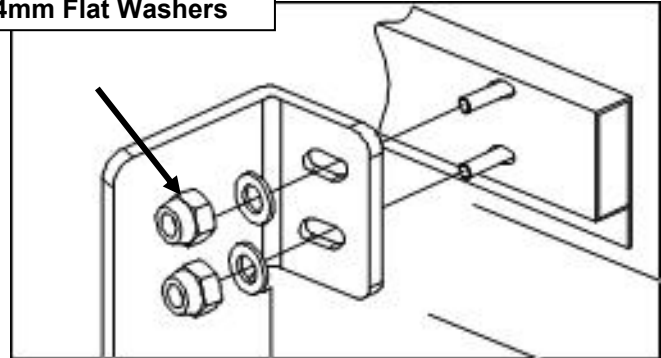

(Fig 2)



(Fig 3) Slip M6 T-bolts into the bottom channel

- (2)M6T-bolts
- (2)M6 Flat Washers
- (2)M6 Nylon Lock nuts

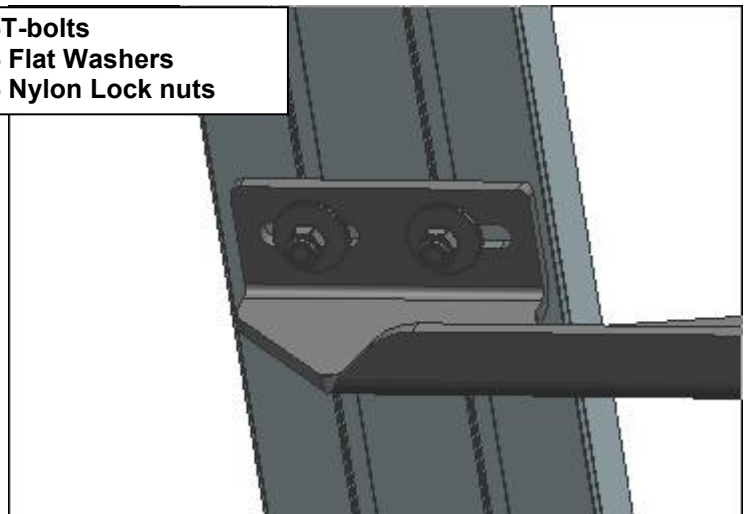

(Fig 4) Bracket Installation