

# Installation Instructions for IB13EBB4

by APS Auto Parts Specialist Inc.

Application: For 1999-2003 Mitsubishi Montero/Pajero Sport  
Estimated Time: 1 to 2 hours



Disclaimer: Instructions intended for persons aged 18+ please do not attempt without adult supervision. Instructions are not intended to replace professional installation. Damage from improper installation, misuse or modification to the product voids the manufacturer's warranty.

### PARTS LIST:

Item	QTY	Description	Item	QTY	Description
#01	2	Running Board(use for left or right)	#06	6	M8X1.25 - 25mm Hex Bolts
#02	4	Front or Rear Mounting Bracket	#07	16	M6X1.0 Nylon Lock Nuts
#03	6	M8 Hex Nuts	#08	16	M6X1.0 - 20mm T-Bolts
#04	6	M8 Lock Washers	#09	16	6mm x 22mm OD x 2mm Flat Washer
#05	12	8mm ID x 24mm OD x 2mm Flat Washers			



### PROCEDURE:

- 1. REMOVE CONTENTS FROM BOX. VERIFY ALL PARTS ARE PRESENT. READ FACTORY BODY BOLT REMOVAL INSTRUCTIONS AND INSTALLATION INSTRUCTIONS CAREFULLY BEFORE STARTING INSTALLATION.**
- Starting on the driver side of the vehicle, locate the (1) factory bolt in the bottom of the outer frame channel, Remove Factory bolt .Position the Front or Rear Mounting Bracket up to the frame rail. Secure the Mounting Bracket with the (1) factory bolts, **(Figure 1)**. Snug but do not tighten hardware at this time.
- Attach the vehicle to the Mounting Brackets with (1) M8 x 25mm Hex Bolts, (1) M8 Lock Washers, (1) M8 Lock nuts and (2) M8 Flat Washers, **(Figure 1)**. Do not tighten hardware at this time.
- Moving to the rear of vehicle. Select the Front or Rear Mounting Bracket, Attach the Front or Rear Mounting Bracket to vehicle with (2) M8 x 25mm Hex Bolts, (2) M8 Lock Washers, (2) M8 Lock nuts and (4) M8 Flat Washers, **(Figure 2)**
- Select the Running Board. Slip (8) 6mm T-Bolts into each bottom channel **(Figure 3)**.Carefully position the Running Board onto the Mounting Brackets. Attach the Running Board to the Mounting Brackets with (4) M6 T-bolts, (4)M6 flat washers and (4)M6 nylon lock nuts, **(Figure 4)**. Do not tighten hardware at this time.
- Level and adjust Running Board properly and tighten all hardware.
- Repeat **Steps 2—6** for passenger/right Running Board installation.
- Do periodic inspections to the installation to make sure that all hardware is secure and tight

**To protect your investment**, wax this product after installing. Regular waxing is recommended to add a protective layer over the finish. Do not use any type of polish or wax that may contain abrasives that could damage the finish.

**For Polished Finishes:** Aluminum polish may be used to polish small scratches and scuffs on the finish. Mild soap may be used also to clean the Running Board.

**For Black Finishes:** Mild soap may be used to clean the Running Board.

### Driver Side Installation Pictured

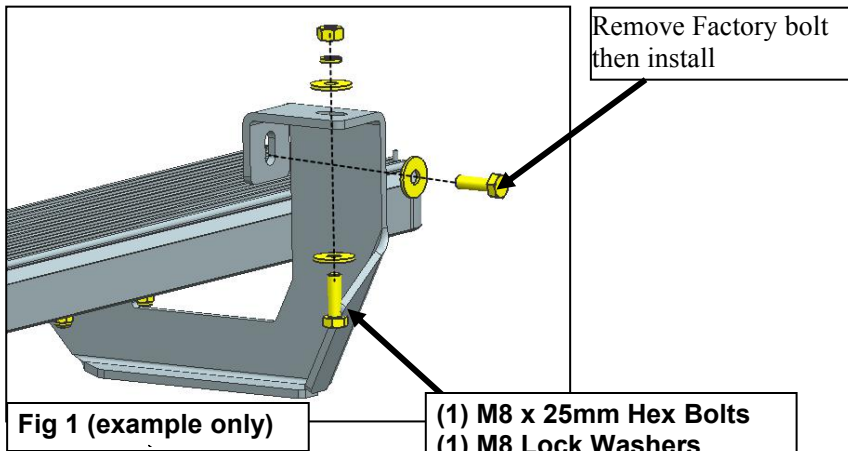

- (1) M8 x 25mm Hex Bolts
- (1) M8 Lock Washers
- (2) M8 Flat Washers
- (1) M8 Hex Nuts

- (2) M8 x 25mm Hex Bolts
- (2) M8 Lock Washers
- (4) M8 Flat Washers
- (2) M8 Hex Nuts

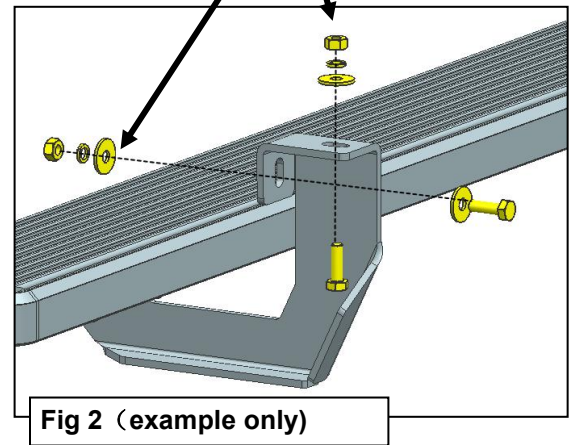

Slip M6 T-bolts into the bottom channel

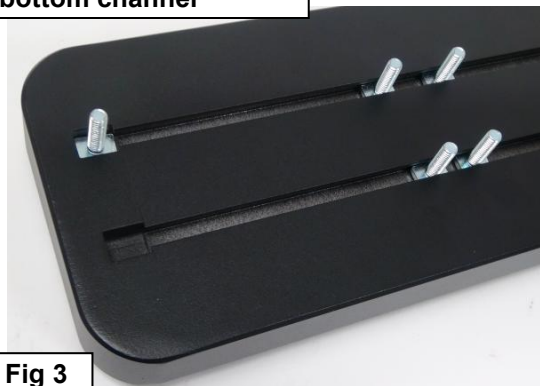

- (4)M6 T-bolts
- (4)M6 Flat Washers
- (4)M6 Nylon Lock nuts

