



## iRunning Board Installation Instruction

Part#: IB-JR964

Application: For 2011-2018 Jeep Grand Cherokee (Excl. Diesel Model) \ Will not fit with OE skirt cladding (Drilling Required)

### PARTS LIST:

Item	QTY	Description	Item	QTY	Description
#01	2	Running Boards	#10	2	M10 J Bolts
#02	1	Driver Front Mounting Bracket (DFM)	#11	2	M10X35mm Hex Bolt
#03	1	Driver Rear Mounting Bracket (DRM)	#12	4	M10 Large Flat Washers
#04	1	Passenger Front Mounting Bracket (PFM)	#13	4	M10 Lock Washer
#05	1	Passenger Rear Mounting Bracket (PRM)	#14	2	M10 Hex Nuts
#06	8	M8X20mm Hex Bolt	#15	8	M6 Square Hex Bolt
#07	16	M8 Flat Washers	#16	8	M6 Flat Washers
#08	8	M8 Hex Nuts	#17	8	M6 Nylon Lock Nuts
#09	8	M8 Internal Tooth Lock Washers			



PFM



DFM



PRM



DRM

### INSTALLATION INSTRUCTION:

**REMOVE CONTENTS FROM BOX. VERIFY ALL PARTS ARE PRESENT. READ INSTRUCTIONS CAREFULLY BEFORE STARTING INSTALLATION.**

1. Remove contents from box and check for damage. Verify that all parts listed above are present. Carefully read all installation instructions before installing  
Starting from the front drivers side of the vehicle Install J-Bolt in the large hole in the frame . (fig 1, 2)
2. Note: The Jeep Grand Cherokee requires pinch weld holes used for installation to be drilled out to 3/8". Dodge Durango requires pinch weld holes used for installation to be drilled out to 3/8" and one additional hole to be drilled through the pinch weld in the rear of the vehicle.(fig 6)
3. Install front bracket to the J-Bolt using (1) large flat washer, (1) large split lock washer and (1) 3/8" hex nut. Secure the front bracket to the outside of the pinch weld using (2) M8 hex head bolts, (4) M8 flat washers, (2) M8 internal tooth lock washers and (2) M8 hex nus. Do not tighten fully at this time. (fig 3,4)
4. Remove the M10 fuel tank strap bolt and install the rear bracket using (1) M10 hex head bolt, (1) large flat washer and (1)split lock washer. Secure the rear bracket to the outside of the pinch weld using (2)

## iRunning Board Installation Instruction

**Part#: IB-JR964**

**Application: For 2011-2018 Jeep Grand Cherokee (Excl. Diesel Model) \ Will not fit with OE skirt cladding (Drilling Required)**

M8 hex head bolts, (4) M8 flat washers, (2) M8 internal tooth,lock washers and (2) M8 hex nuts. Do not tighten fully at this time. (FIG 5,6)

5. Take the drivers side running board and slide (4) M6 square head bolts into the grooves in the bottom of the running boards. Align the square head bolts to the holes in the mounting brackets and attach using (4)M6 flat washers, and (4) M6 nylon lock nuts. Do not fully tighten at this time. (FIG 7,8)
6. Repeat steps 2-5 for the passenger side.
7. Tighten all fasteners at this time. Torque all M10 fasteners to 35-40 ft lbs, and M8 to 30 ft lbs, M6 to 25 ft lbs, and 3/8" fasteners to 35-30 ft lbs. **INSTALLATION IS COMPLETE.**
8. Do periodic inspections of the installation to make sure that all hardware is secure and tight.

**To protect your investment**, wax this product after installing. Regular waxing is recommended to add a protective layer over the finish. Do not use any type of polish or wax that may contain abrasives that could damage the finish.

**For Polished Finishes:** Aluminum polish may be used to polish small scratches and scuffs on the finish. Mild soap may be used also to clean the Running Board.

**For black finishes:** Mild soap may be used to clean the Running Board.

### **Driver/left Side Installation Pictured**

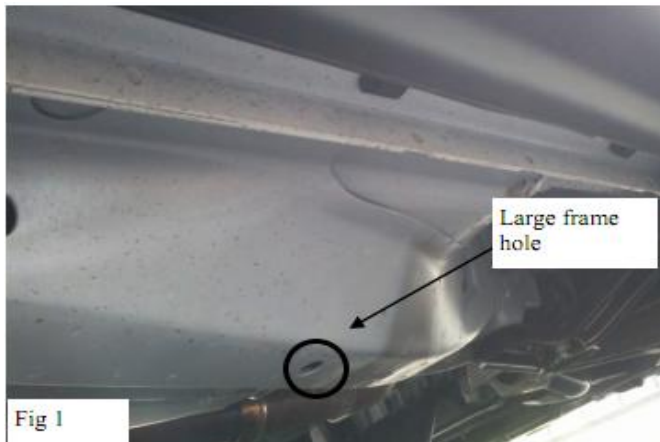

# iRunning Board Installation Instruction

Part#: IB-JR964

Application: For 2011-2018 Jeep Grand Cherokee (Excl. Diesel Model) \ Will not fit with OE skirt cladding (Drilling Required)

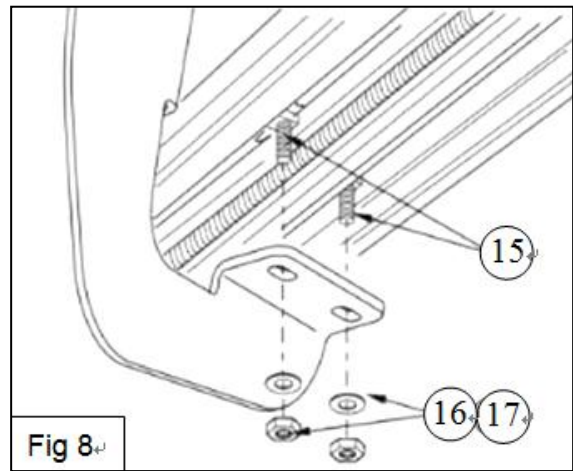
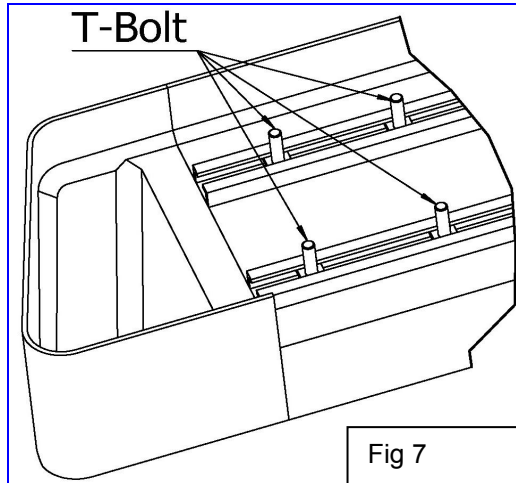
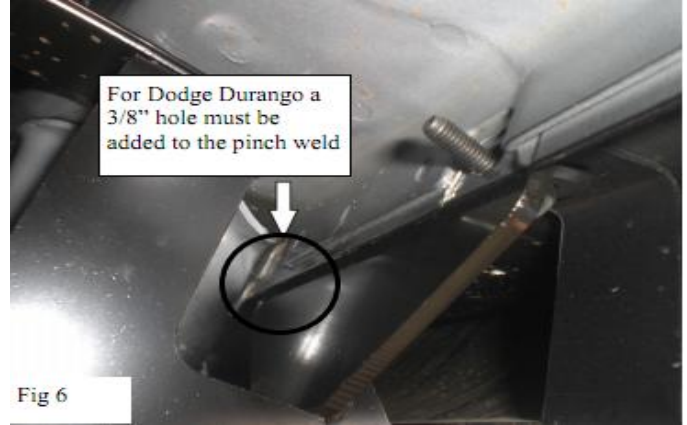

**Install complete**