

Installation Instructions for IB10EAI2

by APS Auto Parts Specialist Inc.

Application:For 2007-2015 Jeep Patriot
Estimated Time: 1 to 2 hours



Disclaimer: Instructions intended for persons aged 18+ please do not attempt without adult supervision. Instructions are not intended to replace professional installation. Damage from improper installation, misuse or modification to the product voids the manufacturer's warranty.

PARTS LIST:

Item	QTY	Description	Item	QTY	Description
#01	2	Running Board(use for left or right)	#14	14	12mm Flat Washers
#02	1	Driver/Left Front Mounting Bracket (DFB)	#15	10	12mm Hex Nuts
#03	1	Passenger/Right Front Mounting Bracket (PFB)	#16	2	10mm x 35mm Hex Bolts
#04	1	Driver/Left Front Frame Bracket (DFM)	#17	2	10mm Lock Washers
#05	1	Passenger/Right Frame Bracket (PFM)	#18	4	10mm Flat Washer
#06	1	Driver/Left Front Support Bracket (DFS)	#19	2	10mm Hex Nuts
#07	1	Passenger/Right Front Support Bracket (PFS)	#20	2	8mm x 35mm Hex Bolts
#08	1	Driver/Left Rear Mounting Bracket (DRB)	#21	2	8mm Lock Washers
#09	1	Passenger/Right Rear Mounting Bracket (PRB)	#22	4	8mm Flat Washers
#10	4	12mm x 45mm Bolt Plates	#23	2	8mm Hex Nuts
#11	2	12mm x 30mm Bolt Plates	#24	16	6mm x 20mm T-Bolts
#12	4	12mm x 35mm Hex Bolts	#25	16	6mm Flat Washers
#13	10	12mm Lock Washers	#26	16	6mm Nylon Lock Nuts



PROCEDURE:

REMOVE CONTENTS FROM BOX. VERIFY ALL PARTS ARE PRESENT. READ INSTRUCTIONS CAREFULLY BEFORE STARTING INSTALLATION. DRILLING AND CUTTING IS REQUIRED. ASSISTANCE IS RECOMMENDED.

1. Starting at the driver side front of the vehicle, locate the three factory holes, (1 round and 2 oval holes), in the bottom of the left front floor panel, **(Figure 1)**. Insert (1) 12mm x 45mm Bolt Plate into the smaller, (inner), oval hole and feed the threaded end back out through the larger, (outer), oval hole, **(Figures 2A & 2B)**. Next, insert (1) 12mm Bolt Plate into the oval hole in the bottom of the inner frame channel, **(Figure 3)**.
2. Attach the driver side front Frame Mounting Bracket to the (2) Bolt Plates with the included (2) 12mm Flat Washers, (2) 12mm Lock Washers and (2) 12mm Hex Nuts, **(Figure 4)**. Do not tighten hardware at this time.

3. Select the driver/left front Mounting Bracket. Bolt the Mounting Bracket to the back of the Frame Bracket with the included (2) 12mm Hex Bolts, (4) 12mm Flat Washers, (2) 12mm Lock Washers and (2) 12mm Hex Nuts, **(Figure 5B)**. Do not tighten at this time.
4. Next, select the driver side Front Support Bracket, **(Figure 5A)**. Attach the Support Bracket to the front side of the Mounting Bracket with (1) 10mm Hex Bolt, (2) 10mm Flat Washers, (1) 10mm Lock Washer and (1) 10mm Hex Nut, **(Figure 5B)**. Leave completely loose at this time.
5. Move along the side of the vehicle toward the rear. Locate the large oval slot in the floor panel. Insert (1) 12mm x 30mm Bolt Plate into the slot, **(Figure 6A)**. **NOTE:** Rotate the Bolt Plate so that the plate is across, not inline with the oval hole, **(Figure 6B)**.
6. Attach the driver side rear Mounting Bracket to the 12mm x 30mm Bolt Plate with (1) 12mm Lock Washer and (1) 12mm Hex Nut, **(Figure 7)**. **NOTE:** A deep socket is required to tighten the Hex Nut up into the Bracket. Snug but do not fully tighten hardware at this time.
7. With the Running board Bracket hardware loose, pull the Brackets outward away from the vehicle for proper clearance.
8. Select the Running Board. Slip (8) 6mm T-Bolts into each bottom channel **(Figure 10)**. Carefully position the Running Board onto the Mounting Brackets. Attach the Running Board to the Mounting Brackets with (4) 6mm T-bolts,(4)6mm flat washers and (4)6mm nylon lock nuts, **(Figure 11)**. Do not tighten hardware at this time.
9. Line up the Front Support Bracket with the back of the pinch weld, **(Figure 8)**. Push the Support Bracket up as high as possible to where the pinch weld meets the floor panel. Snug but do not fully tighten hardware.
10. Check the Running Board for level. Once properly aligned and adjusted, tighten all hardware. **IMPORTANT:** If the Support Bracket is too low and close to the edge of the pinch weld, loosen the Support Bracket and front Bracket hardware. Push the Bracket and Support Bracket up a little into position against the floor panel and away from the edge of the pinch weld, **(Figure 8)**. Level and adjust the Running Board properly and tighten all hardware.
11. Use the hole in the Support Bracket as a guide to mark the drilling location on the back of the pinch weld, **(Figure 8)**. Once you have marked the location, temporarily remove the Sidebar, the front Mounting Bracket and Support Bracket. Remove the plastic clips securing the plastic rocker cover to the rocker panel.
12. Use a 5/16" drill bit and carefully drill the marked location. **NOTE:** The plastic rocker panel cover may need to be trimmed to clear the hex bolt for the Support Bracket. **IMPORTANT:** Any cutting or drilling tool may break or shatter. Government regulations require safety glasses & equipment at all times when cutting or drilling.
13. Re-install the driver side front Mounting Bracket and Support Bracket. Attach the Support Bracket to the pinch weld with (1) 8mm x 35mm Hex Bolt, (2) 8mm Flat Washers, (1) 8mm Lock Washer and (1) 8mm Hex Nut, **(Figure 9)**. **NOTE:** Insert the 8mm Hex Bolt with (1) 8mm Flat Washer through the pinch weld first, then through the Bracket. Cut the rocker panel cover as required and reinstall the cover with the factory plastic clips. Reinstall the Running Board.
14. Level and adjust the Running Board and fully tighten all hardware.
15. Repeat **Steps 2—14** for passenger Running Board installation.
16. Do periodic inspections to the installation to make sure that all hardware is secure and tight.

To protect your investment, wax this product after installing. Regular waxing is recommended to add a protective layer over the finish. Do not use any type of polish or wax that may contain abrasives that could damage the finish.

For Polished Finishes: Aluminum polish may be used to polish small scratches and scuffs on the finish. Mild soap may be used also to clean the Running Board.

For Black Finishes: Mild soap may be used to clean the Running Board.

Driver Side Installation Pictured

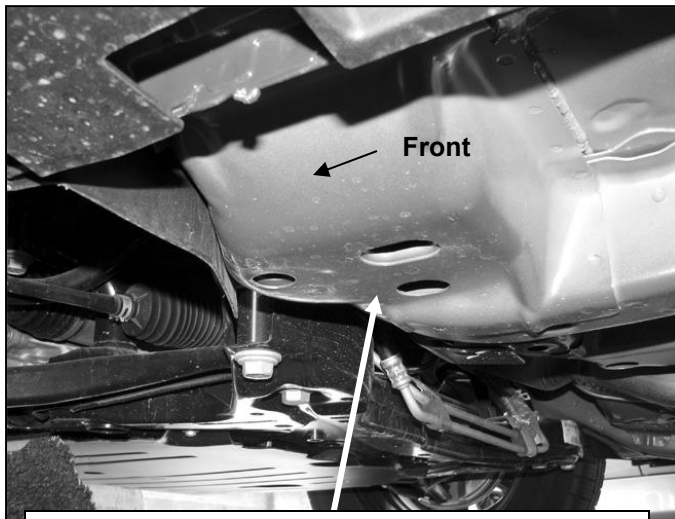

(Fig 1) Driver side front mounting location

12mmX45mm Bolt Plate
12mm Flat Washer
12mm Lock Washer
12mm Hex Nut



Fig 2A

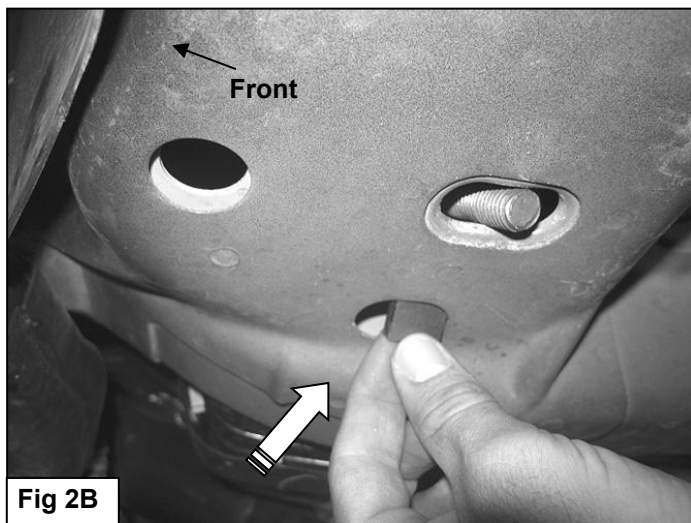
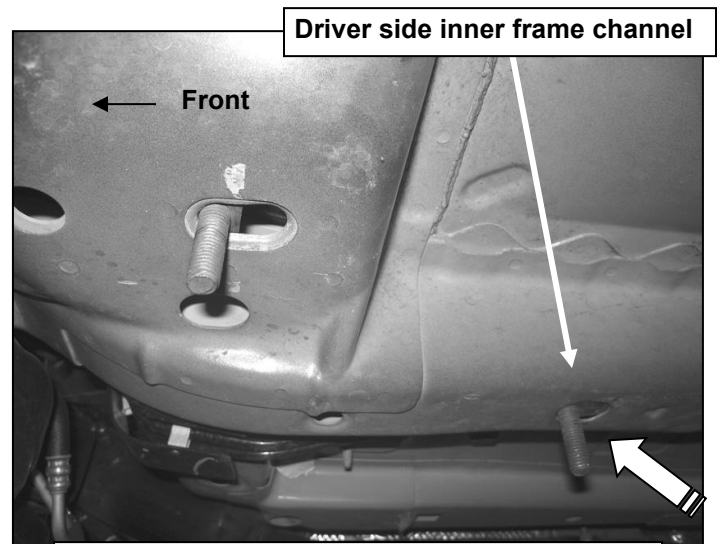

Fig 2B

Insert (1) 12mm Bolt Plate into the inner small oval hole and back out the larger oval hole



(Fig 3) Insert (1) 12mm Bolt Plate into the hole in the bottom of the inner frame channel

Driver Side Installation Pictured

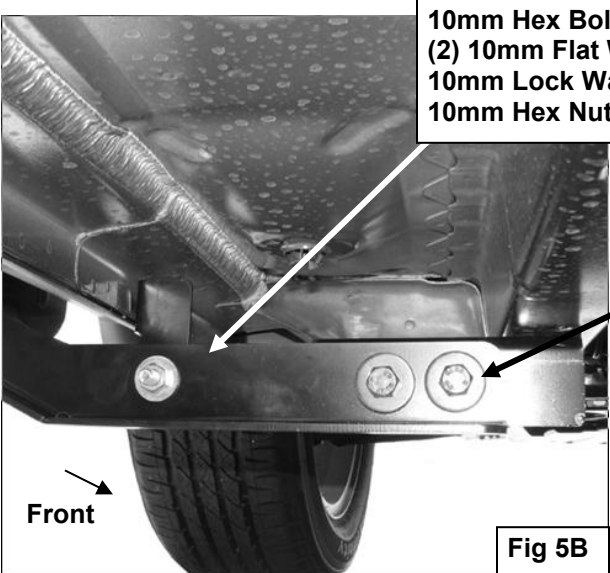
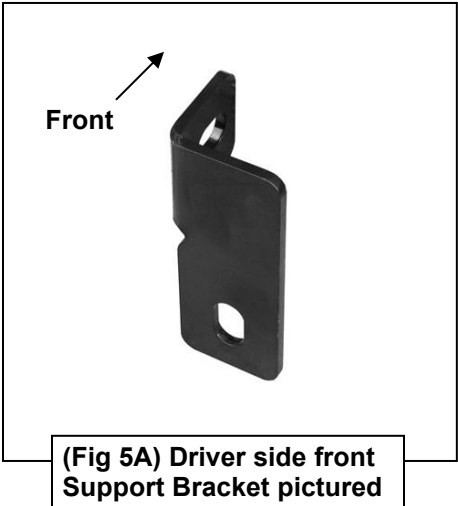
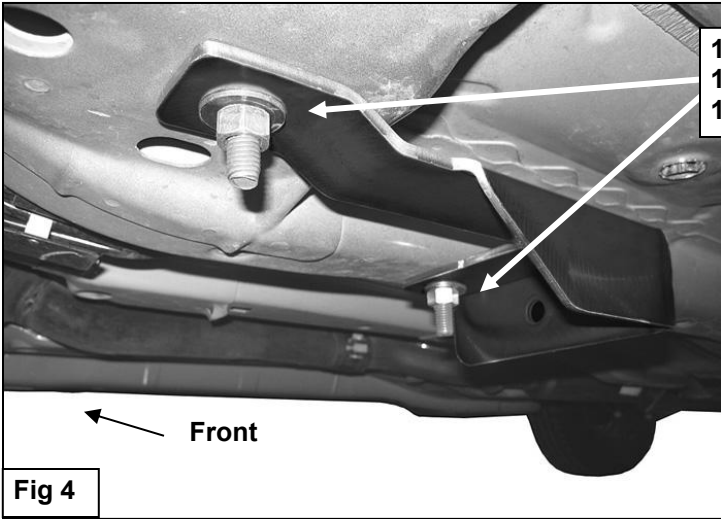

- (2) 12mm Hex Bolts
- (2) 12mm Lock Washers
- (4) 12mm Flat Washers
- (2) 12mm Hex Nuts

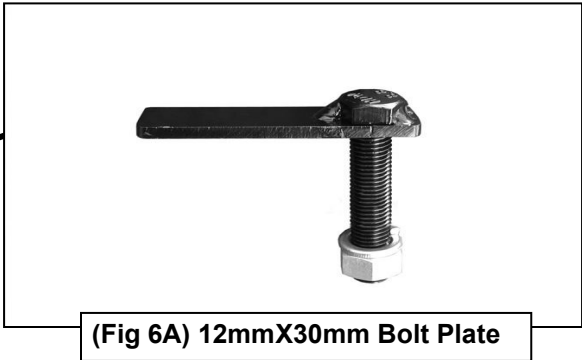
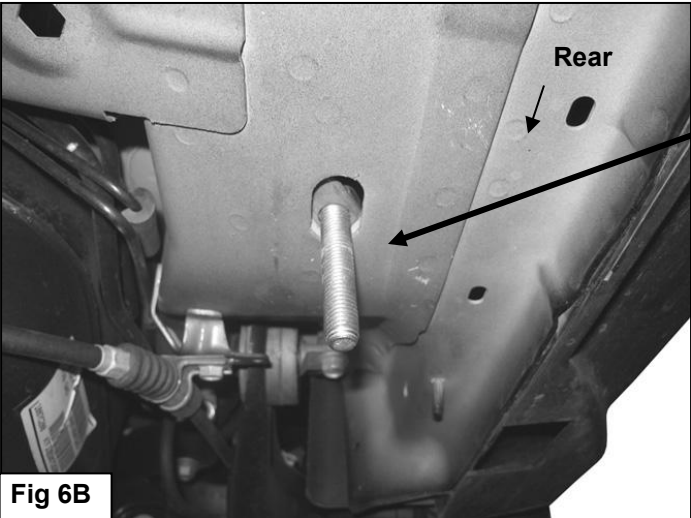

Driver Side Installation Pictured

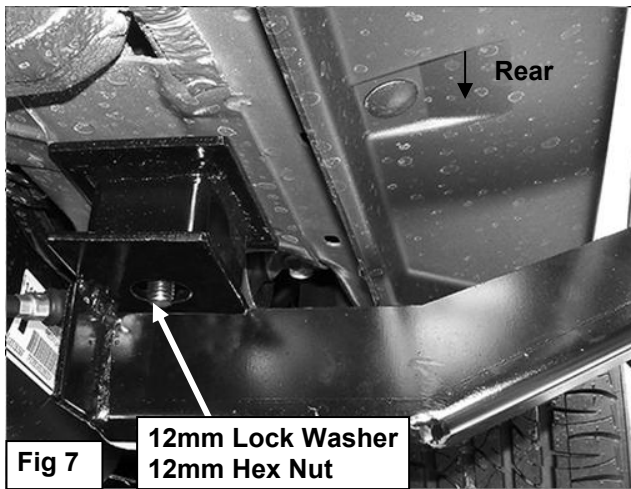

Fig 7

12mm Lock Washer
12mm Hex Nut

Drill 5/16" hole through marked spot on pinch weld. Do not drill close to the edge of the pinch weld

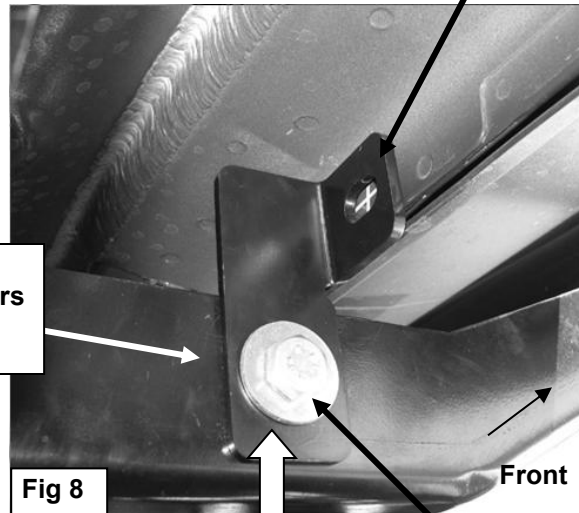

Fig 8

Front

8mm x 35mm Hex Bolt
8mm Lock Washer
(2) 8mm Flat Washers
8mm Hex Nut

10mm Hex Bolt
(2) 10mm Flat Washers
10mm Lock Washer
10mm Hex Nut

Adjust Running board. Loosen 10mm Bolt and push Support Bracket up against the floor to move slot away from edge of pinch weld

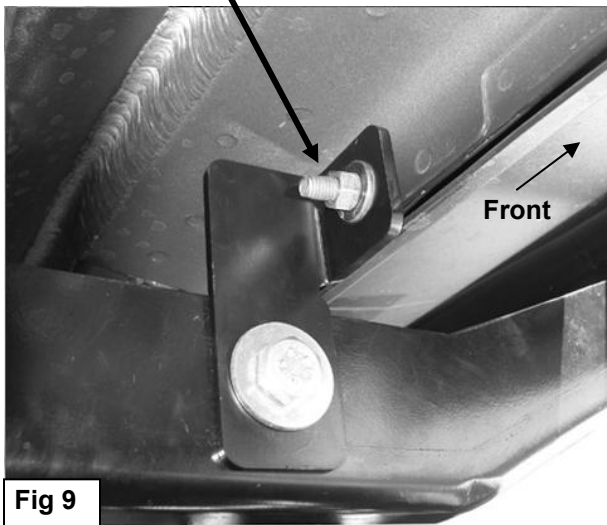

Fig 9

Front



(Fig 10) Slip 6mm T-bolts into the bottom channel

(4)6mm T-bolts
(4)6mm Flat Washers
(4)6mm Lock nuts

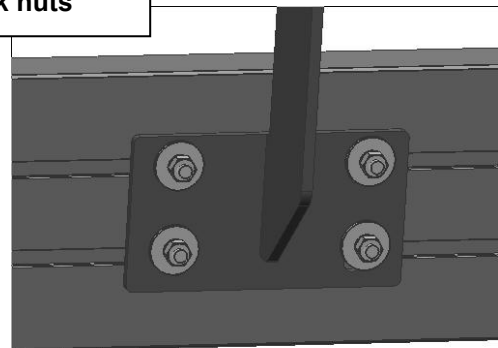

(Fig 11) Running board Installation