



# Installation Instruction

Part#:IB10EBA9B

Application:For 08-13 Jeep Liberty

Item	Part Name	QTY	Item	Part Name	QTY
1	Driver Sidebar	1	9	M10 Nylon lock Nuts	4
2	Passenger Sidebar	1	10	10mm Flat Washers	4
3	Passenger /Right Front Mounting Bracket	1	11	M8 x1.25-25 Hex Head Bolts	16
4	Driver/Left Front Mounting Bracket	1	12	M8 x1.25-35 Hex Head Bolts	8
5	Passenger /Right Rear Mounting Bracket	1	13	M8 Nylon lock Nuts	8
6	Driver/Left Rear Mounting Bracket	1	14	M8 Lock Washers	16
7	Fit Adjustment Spaces(127 x25 x3)	6	15	8mm Flat Washers	32
8	M10 x25 Bolt Plates	4			

### Driver Side Mounting Brackets



Longer Bracket

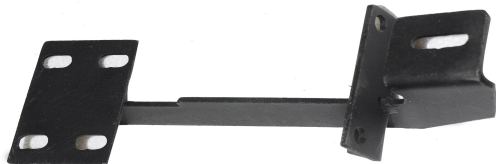

Shorter Bracket

### Passenger Side Mounting Brackets

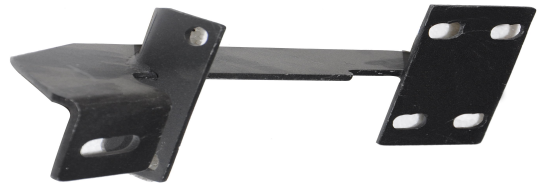

Longer Bracket



Shorter Bracket

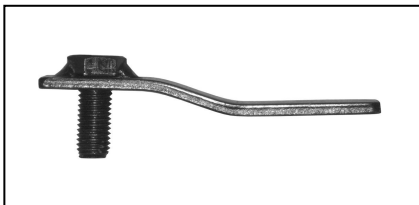

**Bolt Plate  
(4 pcs)**

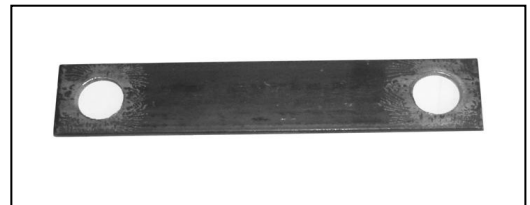

**Fit Adjustment Spacers  
(6 pcs)**

The instruction here is for your reference only. We strongly recommend the professional installer for best result. We are not responsible for any damage caused by the installation. Thank you for choosing our product!

# Installation Instruction

Part#:IB10EBA9B

Application:For 08-13 Jeep Liberty

Step	Installation Instruction
1	<b><u>CHECK PART LIST AND MAKE SURE ALL COMPONENTS ARE PRESENT. READ FOLLOWING INSTRUCTIONS CAREFULLY BEFORE STARTING INSTALLATION. DRILLING REQUIRED.</u></b>
2	Starting on the driver side front of the vehicle, insert (1) M10 x25 Bolt Plates into rectangular hole located in the side panel, so threaded Bolt Plate drops through round hole (Figure 1).
3	Partially hang driver side front Mounting Bracket to already inserted Bolt Plate using the included (1) 10mm Ny-lock Nuts and (1) 10.5 x27 x3 Flat Washers to secure it(Figure 2). <b>NOTE:</b> Rear Mounting Brackets are 1/4" longer than front Mounting Brackets and the 10mm mounting tab location on the brackets face the front of the vehicle. Make sure that the vertical mounting locations in the Brackets are on the outer side of pinch weld.
4	Attach Mounting Bracket to pinch weld using the included (2) M8 x1.25-35 Hex Head Bolts, (2) M8 Nylock Nuts, and (4) 8.5 x 24 x 2 Flat Washers .Do not tighten at this time. <b>NOTE:</b> Depending upon the vehicle,the front of the Sidebar might make contact with front factory flares. If so, place one ,two, or three of the Fit Adjustment Spacers on the outside of the pinch weld between the Mounting Bracket and the pinch weld as needed(Figure 2).
5	Repeat steps 2-4 for drive side rear Mounting Bracket(Figure 3).
6	Position driver Sidebar onto Mounting Brackets. Attach Sidebar to Mounting Brackets using the included(8) M8 x1.25-25 Hex Head Bolts,(8) Lock Washers, and (8) Flat Washers (Figure 5). Do not tighten at this time.
7	Level and adjust Sidebar properly; and then tighten all hardware at this time.
8	Repeat Steps 2-7 for passenger Sidebar (Figure 6&7).
9	Do periodic inspections to the installation to make sure that all hardware is secure and tight.

**To protect your investment**, wax this product after installing, Regular waxing is recommended to add a protective layer over the finish. Do not use any type of polish or wax that may contain abrasives that could damage the finish.

**For stainless steel:**Aluminum polish may be used to polish small scratches and scuffs on the finish.

**For gloss black finishes:**Mild soap may be used to clean the sidebar.

**Bolt Plate** →



**Fig 1**

The instruction here is for your reference only. We strongly recommend the professional installer for best result. We are not responsible for any damage caused by the installation. Thank you for choosing our product!

# Installation Instruction

Part#:IB10EBA9B

Application:For 08-13 Jeep Liberty

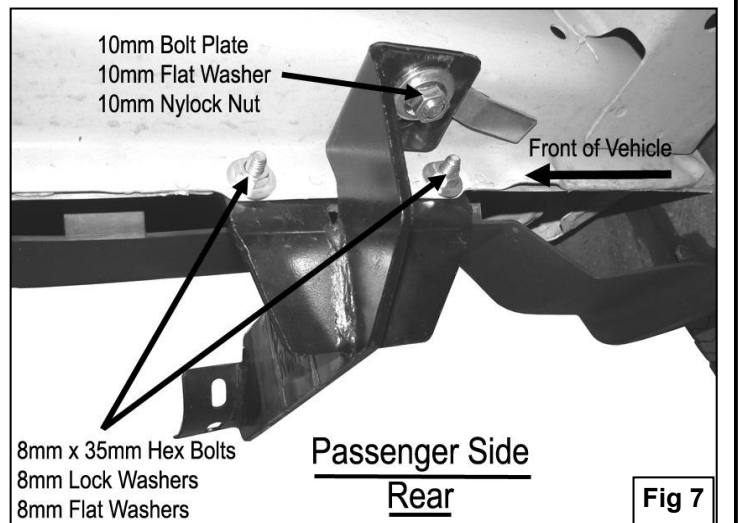
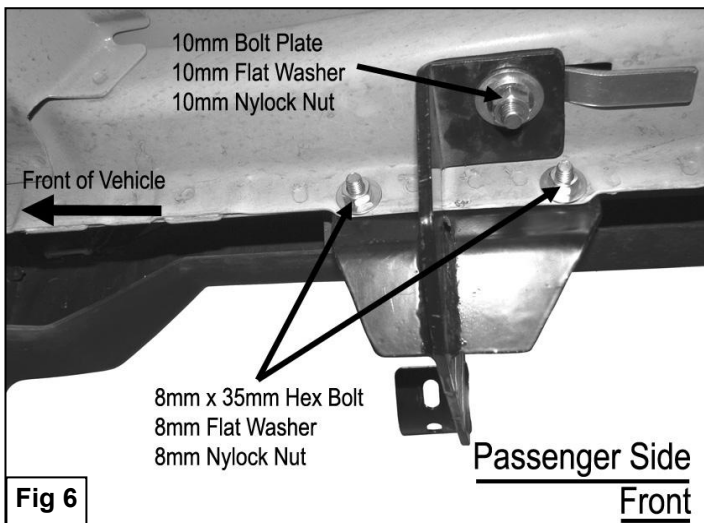
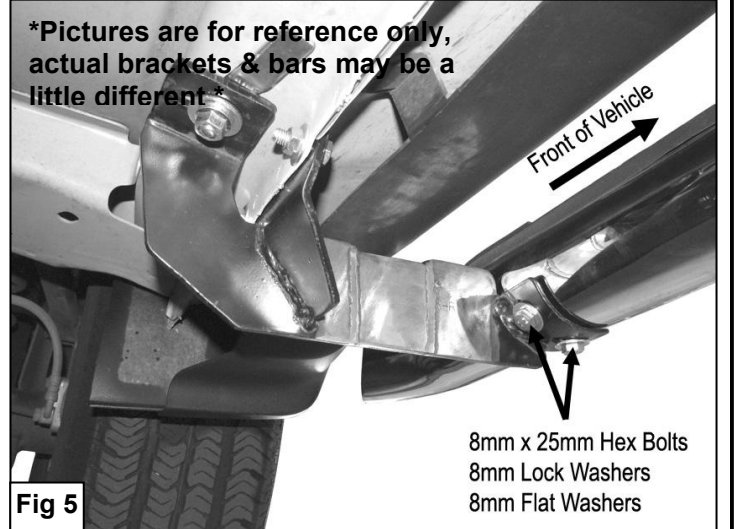
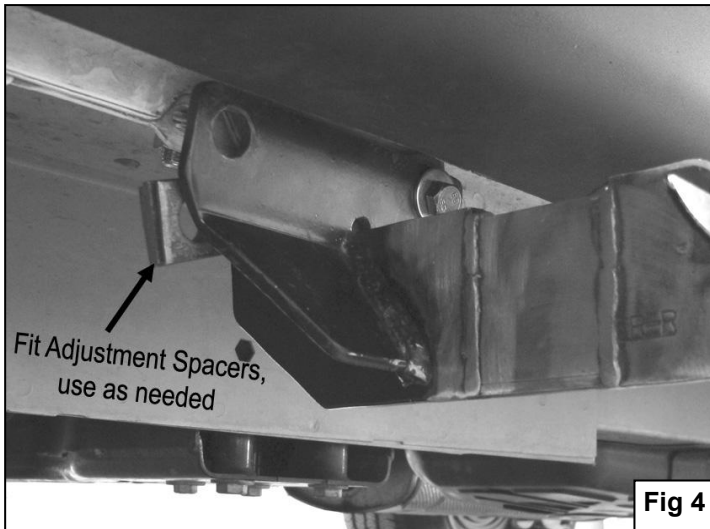
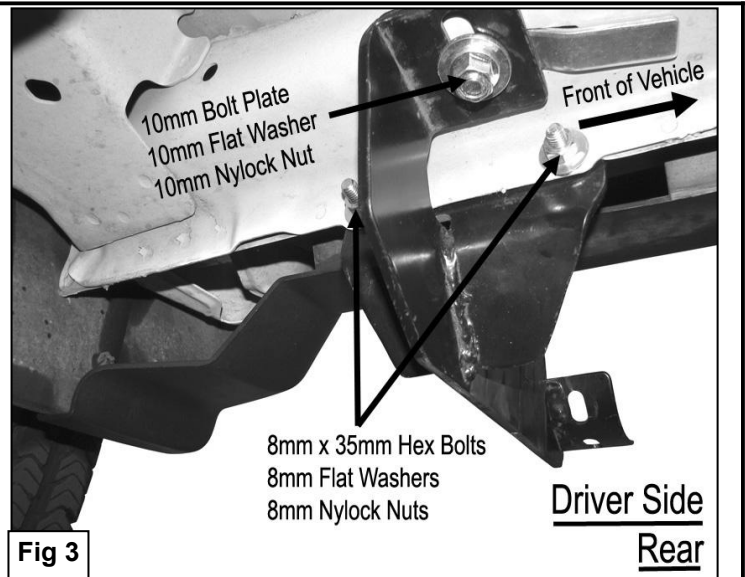
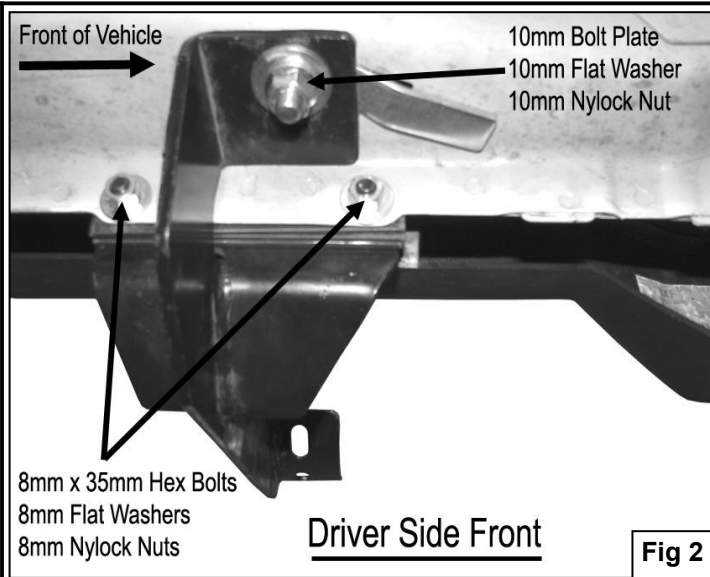

The instruction here is for your reference only. We strongly recommend the professional installer for best result. We are not responsible for any damage caused by the installation. Thank you for choosing our product!