

Installation Instructions for IB08EAB3

by APS Auto Parts Specialist Inc.

Application: For 2003-2011 Honda Element (Excl. SC Model)

Estimated Time: 1 to 2 hours



Disclaimer: Instructions intended for persons aged 18+ please do not attempt without adult supervision. Instructions are not intended to replace professional installation. Damage from improper installation, misuse or modification to the product voids the manufacturer's warranty.

PARTS LIST:

Item	QTY	Description	Item	QTY	Description
#1	2	Running Board (use for left and right)	#10	4	M10 Hex Nuts
#2	2	Driver Front Mounting Brackets(DFM/PFM)	#11	6	M8-1.25mm x 30mm Hex Bolts
#3	2	Driver Front Support Brackets(DFS/ PFS)	#12	8	M8-1.25mm x 20mm Flange Hex Bolts
#4	1	Driver Rear Mounting Brackets(DRM)	#13	6	8.4mm x 24mm x 2mm Flat Washers
#5	1	Passenger Rear Mounting Brackets(PRM)	#14	6	M8 Lock Washers
#6	4	M10-1.5mm x 35mm Bolt Plates	#15	8	M8 Hex Flange Nuts
#7	4	10mm Plastic Retainers	#16	8	M6X1.0 - 20mm T-Bolts
#8	4	11mm x 20mm OD x 2.2mm Flat Washer	#17	8	6mm x 22mm OD x 2mm Flat Washers
#9	4	M10 Lock Washers	#18	8	M6X1.0 Nylon Lock Nuts

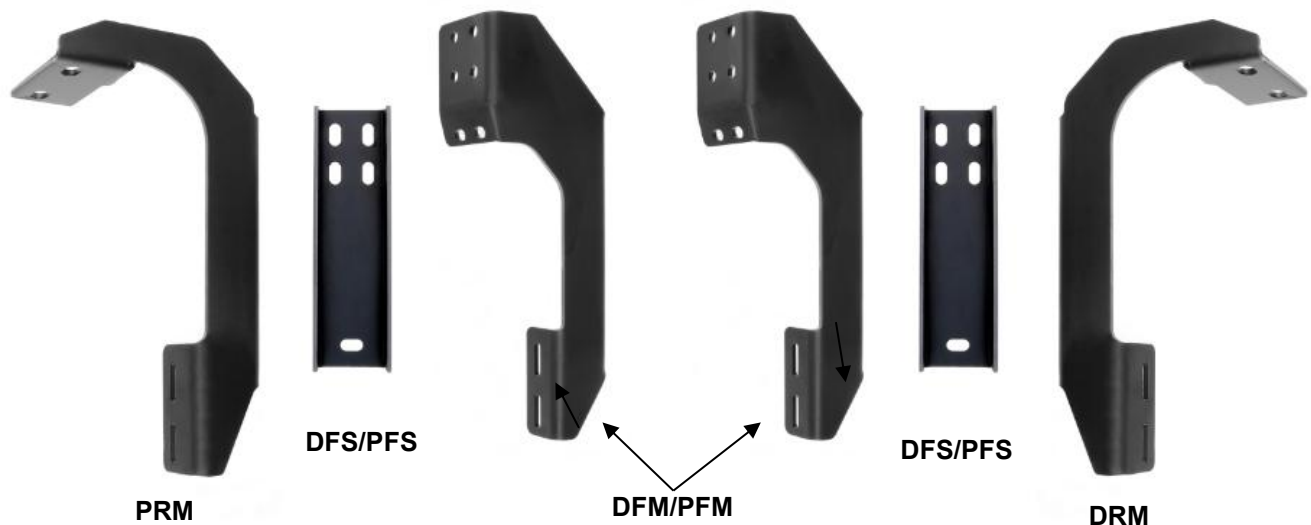

PROCEDURE:

1. REMOVE CONTENTS FROM BOX. VERIFY ALL PARTS ARE PRESENT. READ INSTRUCTIONS CAREFULLY BEFORE STARTING INSTALLATION.
2. Select (1) Front Mounting Bracket and (1) Front Support Bracket, (**Figure 1**). Line up the (4) main mounting holes in both brackets and bolt the Support Bracket to the bottom of the Mounting Bracket with the included (4) M8 x 20mm Flange Hex Bolts and (4) M8 Locking Flange Nuts, (**Figure 2**). Do not tighten hardware at this time.
3. Starting on the driver side front of the vehicle, locate the (2) factory threaded holes in the bottom of the outer frame channel and the single threaded hole in the bottom of the inner frame channel, (**Figure 3A & 3B**). **NOTE:** The threaded holes may be filled with plastic plugs or covered in insulation. Remove plugs or insulation before proceeding.
4. Position the Front Mounting Bracket and Support Bracket up to the vehicle. Hang the Bracket assembly from the two threaded holes using the provided (2) M8 x 30mm Hex Bolts, (2) M8 Lock Washers and (2) M8 Flat Washers, (**Figure 4**). Line up the slot in the end of the Support Bracket with the threaded hole in the inner frame channel. Bolt the Support Bracket to the frame channel with an M8 x 30mm Hex Bolt, M8 Lock Washer and M8 Flat Washer. Snug but do not tighten hardware at this time.
5. Move toward the rear of the vehicle and locate the (2) factory oval holes in the side of the body panel, (**Figure 5A**). Thread (1) Plastic Retainer part way onto (1) M10 Bolt Plate, (**Figure 5B**). Insert the Bolt Plate and Retainer into the oval hole and thread the Plastic Retainer down against the body panel, (**Figure 5A**). Rotate the Bolt Plate 90-degrees so that it is supported across the slot in the

body panel. **IMPORTANT:** The Plastic Retainer is designed to prevent the Bolt Plate from falling into the body cavity and to aid in Bracket installation. Repeat this Step to install the second Bolt Plate in the remaining factory oval hole.

6. Select (1) Driver/Left Rear Mounting Brackets. Hang the Bracket from the (2) M10 Bolt Plates and secure with (2) M10 Flat Washers, (2) M10 Lock Washers and (2) M10 Hex Nuts, (**Figure 6**). Snug but do not fully tighten at this time.
7. Select a Running Board. Slip(4) M6 T-bolts into each bottom channel(**Figure 7**). Carefully position the Running Board onto the (2) Mounting Brackets. **IMPORTANT:** Do not slide, (front to back), the Running Board on the Brackets or damage to the finish may result. Attach the Running Board to the Mounting Brackets with(2) M6 T-bolts,(2)M6 flat washers and (2)M6 nylon lock nuts (**Figures 8**). Do not tighten at this time. Level and adjust the Running Board properly and tighten all hardware at this time.
8. Align the Running Board properly and tighten all hardware.
9. Repeat Steps 2 - 8 for the passenger Running Board installation.
10. Do periodic inspections to the installation to make sure that all hardware is secure and tight.

To protect your investment, wax this product after installing. Regular waxing is recommended to add a protective layer over the finish. Do not use any type of polish or wax that may contain abrasives that could damage the finish. **For Polished Finishes:** Aluminum polish may be used to polish small scratches and scuffs on the finish. Mild soap may be used also to clean the Running Board. **For Black Finishes:** Mild soap may be used to clean the Running Board.

Driver Side Installation Pictured

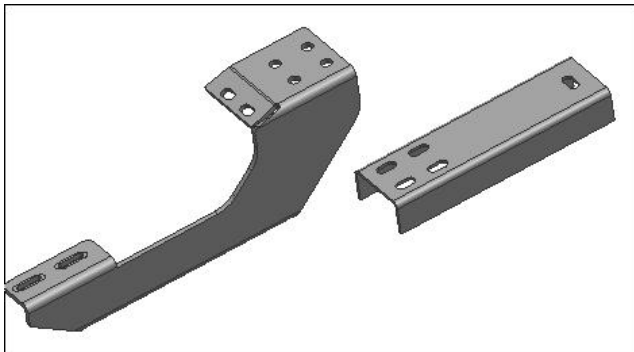

Fig 1

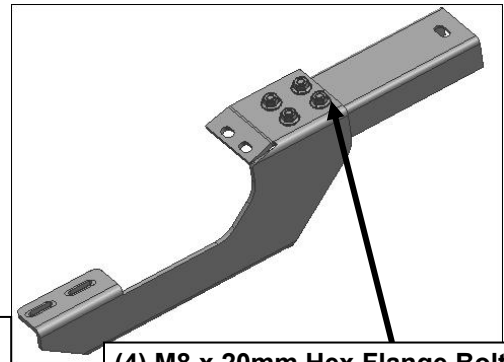
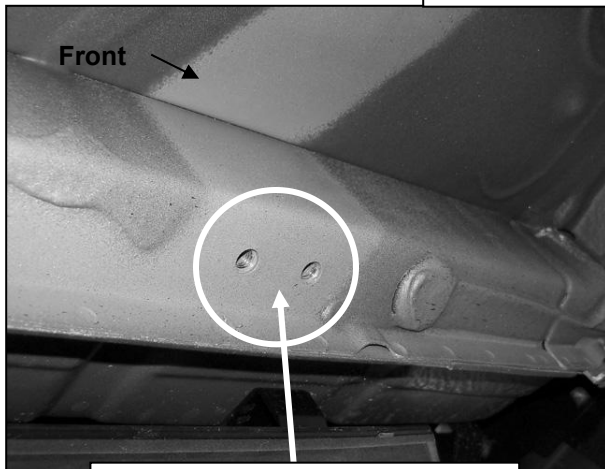

Fig 2

(4) M8 x 20mm Hex Flange Bolts
(4) M8 Flange Nuts

Remove plugs (if equipped) to uncover threaded mounting holes in floor panel



(Fig 3A) Driver Side Front Outer Mounting Location Pictured

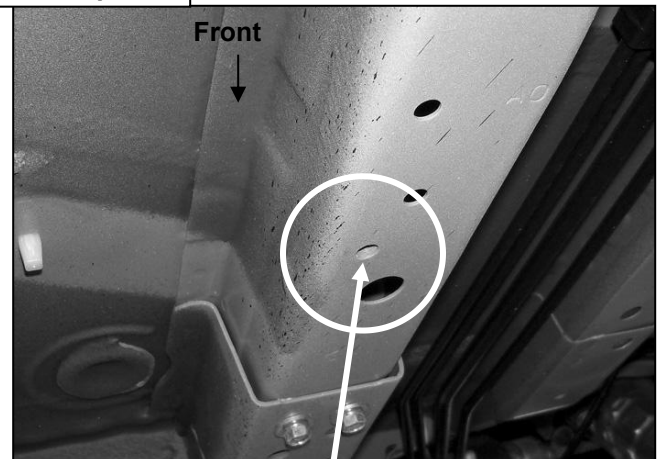

(Fig 3B) Driver Side Front Inner Mounting Location Pictured

Driver Side Installation Pictured

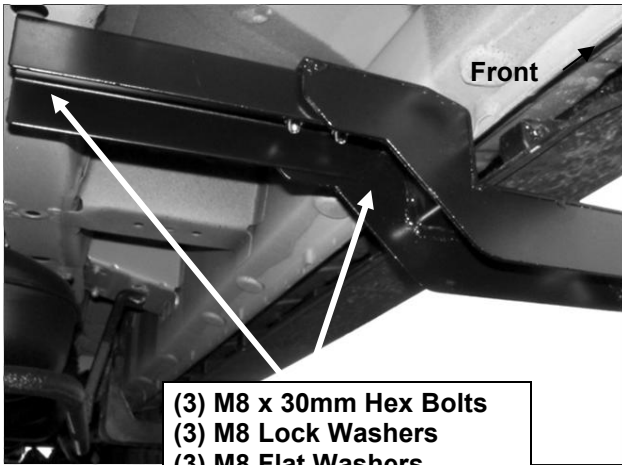

(Fig 4) Driver Side Front Mounting Bracket Assembly Pictured(example only)

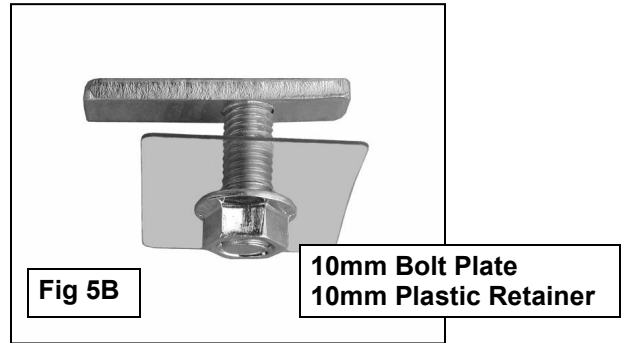

(2) 10mm x 35mm Bolt Plates
(2) 10mm Plastic Retainers
Insert Bolt Plate and rotate 90-degrees
across slot opening in body panel

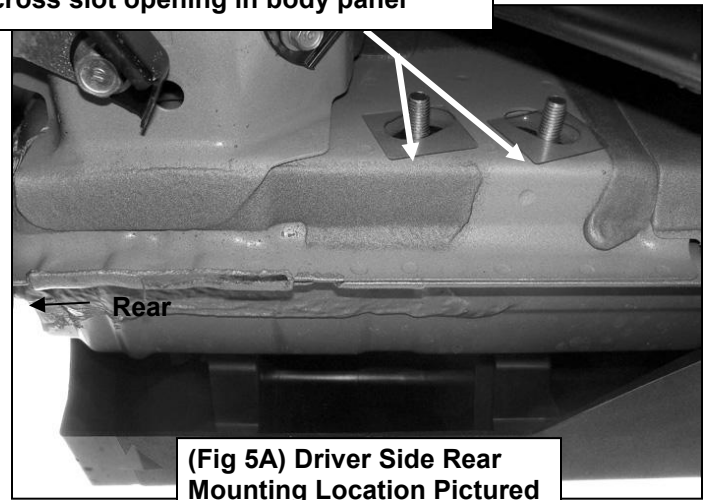

(Fig 5A) Driver Side Rear Mounting Location Pictured

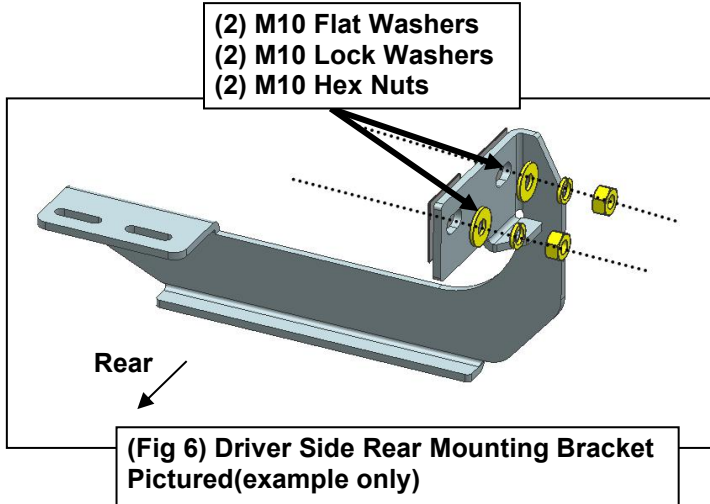

(Fig 6) Driver Side Rear Mounting Bracket Pictured(example only)



(Fig 7) Slip M6 T-bolts into the bottom channel

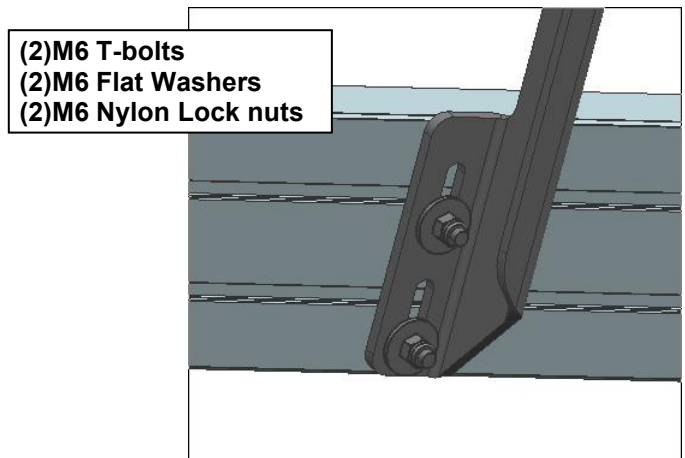

(Fig 8) Drive side Bracket