

PARTS LIST:

Item	QTY	Description	Item	QTY	Description
#01	1	Driver side running board	#13	1	8mm Insert Installation Tool
#02	1	Passenger side running board	#14	4	10-1.50mm x 35mm Hex Bolts
#03	1	Driver Front Mounting Bracket (DFM)	#15	10	10.5mm x 30mm OD x 2.5mm Flat Washers
#04	1	Passenger Front Mounting Bracket(PFM)	#16	6	10mm Lock Washer
#05	1	Driver Front Support Bracket (DFS)	#17	6	10mm Hex Nut
#06	1	Passenger Front Support Bracket (PFS)	#18	12	8-1.25mm x 25mm Hex Bolts
#07	1	Driver Center Mounting Bracket (DCM)	#19	12	8mm Lock Washers
#08	1	Passenger Center Mounting Bracket (PCM)	#20	12	8.4mm x 24mm OD x 2mm Flat Washers
#09	1	Driver Rear Mounting Bracket (DRM)	#21	12	M6 Square Hex Bolt
#10	1	Passenger Rear Mounting Bracket (PRM)	#22	12	M6 Nylon Lock Nuts
#11	2	M10x40mm Bolt Plate	#23	12	M6 Flat Washers
#12	2	8-1.25mm Threaded Insert			

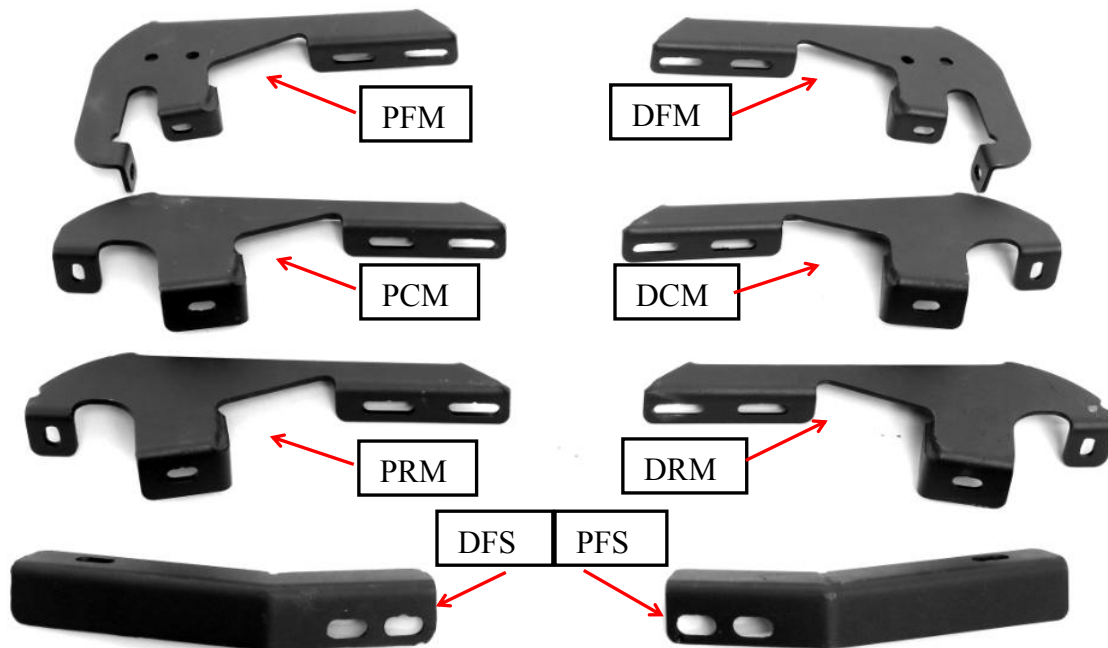

INSTALLATION INSTRUCTION:

- REMOVE CONTENTS FROM BOX. VERIFY ALL PARTS ARE PRESENT. READ INSTRUCTIONS CAREFULLY BEFORE STARTING INSTALLATION.**
- Starting on the driver side of the vehicle, locate the two factory 8mm threaded holes, one located in the bottom of the floor panel and the second in the side of the inner body panel, **(Figures 1)**.
IMPORTANT: All factory threaded holes may be covered with rubber plugs or undercoating. Scrape off any excess undercoating from mounting surfaces.
- Select the driver side Front Mounting Bracket. Attach the Bracket to the two threaded holes using the provided (2) 8mm x 25mm Hex Bolts, (2) 8mm Lock Washers and (2) 8mm Flat Washers. Snug but do not tighten hardware at this time, **(Figures 2)**.
- Select (1) 10mm Bolt Plate, **(Figures 3)**. Insert the Bolt Plate into the factory hole in the bottom of the frame channel, **(Figures 4)**. Rotate the Bolt Plate clock-wise 90- degrees or until it stops turning. **NOTE:** To help determine the correct inner mounting hole on the frame to use, hold the Support Bracket up to the back of the Front Bracket with the inner end lined up with the hole in the bottom of the frame channel. **(Figures 5)**
- Bolt the driver side Support Bracket to the back of the front Mounting Bracket with (2) 10mm x 35mm Hex Bolts, (4) 10 mm Flat Washers, (2) 10mm Lock Washers and (2) 10mm Hex Nuts, **(Figures 5)**. Next , hang the inner end of the Support Bracket from the previously installed Bolt Plate using (1) 10mm Flat Washer, (1) 10mm Lock Washer and (1) Hex Nut. Do not fully tighten hardware at this time.

6. Next, move to the center of the vehicle and locate the (2) 8mm threaded holes located on the bottom to the floor panel and bottom of the frame channel, **(Figures 6)**. Select the driver side Center Mounting Brackets, **(Figures 7)**. **IMPORTANT:** Center and Rear Brackets are similar but unique. To help identify, the Center Brackets feature a notch cut out of the inner end of the Bracket, **(Figures 7)**. Attach the Center Bracket to the two threaded holes using the provided (2) 8mm X 25mm Hex Bolts, (2) 8mm Lock Washers and (2) 8mm Flat Washers, **(Figures 8)**. Snug but do not tighten hardware at this time.
7. Continue along the side of the vehicle to the rear mounting location. Locate the 8mm threaded hole in the bottom of the frame channel, **(Figures 9)**. Locate the factory hole in the bottom of the floor panel. Remove rubber plugs as necessary. **NOTE:** To determine the correct mounting holes to use, hold the driver side rear Mounting Bracket up in position against the factory threaded hole in the end of the frame channel, **(Figures 9)**. Remaining hole in mounting tab on the bracket will line up with correct factory hole in floor panel.
8. Select the 8mm Threaded Insert Tool, (1) 8mm Threaded Insert, (1) 8mm Flat Washer and (1) 8mm x 25mm Hex Bolt, **(Figures 10)**. Assemble the tool as pictured in **Figures 10**. Insert the assembly into the factory hole. Firmly hold the tool handle and assembly up tight against the floor panel and tighten the 8mm Hex Bolt until the insert is fully expanded in the hole, **(Figures 11)**. **NOTE:** Do not over tighten or a pull out may occur. Once Insert is fully compressed, remove the bolt and tool from the Insert.
9. Attach the driver side Rear Bracket to the (2) threaded holes with (2) 8mm x 25mm Hex Bolts, (2) 8mm Lock Washers and (2) 8mm Flat Washers, **(Figures 13)**. Do not tighten hardware at this time.
10. Select the driver/left side Running Board. Locate the openings cut at the end of the slots on the bottom of the Running Board, **(Figures 14)**. Insert (3) M6 Square Hex Bolt into each channel through the openings. Slide the T-Bolts into the approximate position in line with the (3) Brackets on the vehicle.
11. Carefully position the Driver/Left Running Board. Locate the openings cut at the end of the slots on the bottom of the Running Board, **(Figures 14)**. Insert (3) M6 Square Hex Bolt into each channel through the openings. Slide the T-Bolts into the approximate position in line with the (3) Brackets on the vehicle.
12. Level and adjust the Running Board and tighten all hardware.
13. Repeat **Steps 2 - 12** for Passenger Running Board installation.
14. Do periodic inspections to the installation to make sure that all hardware is secure and tight.

To protect your investment: wax this product after installing. Regular waxing is recommended to add a protective layer over the finish. Do not use any type of polish or wax that may contain abrasives that could damage the finish.

For Polished finishes: Aluminum polish may be used to polish small scratches and scuffs on the finish. Mild soap may be used also to clean the Sidebar.

For Black finishes: Mild soap may be used to clean the Sidebar.

Driver Side Installation Pictured

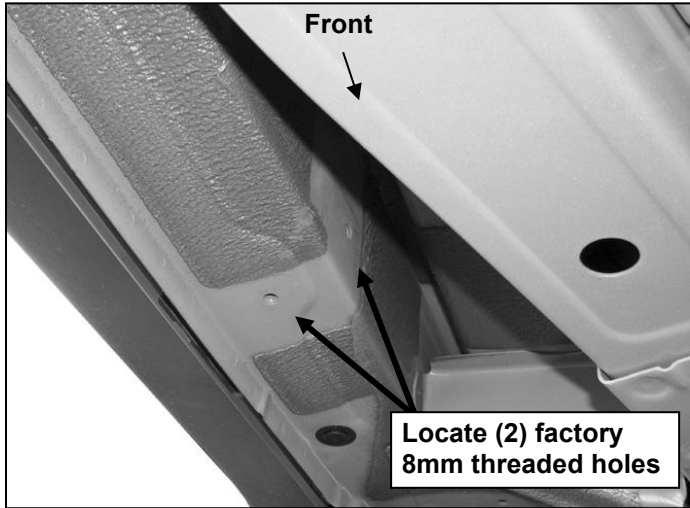

(Fig 1) Driver side front mounting location pictured

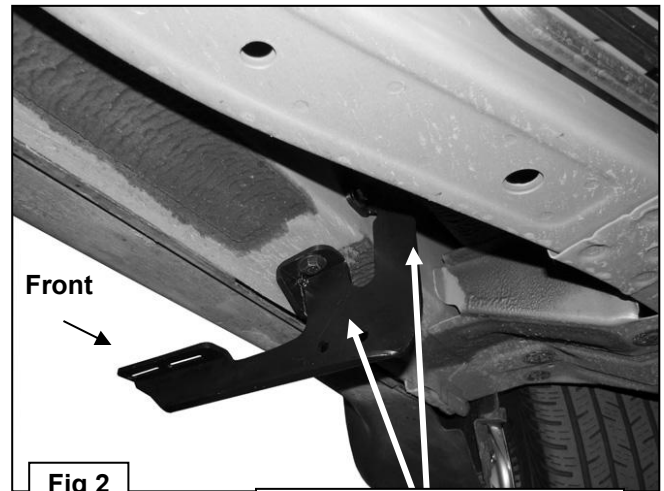
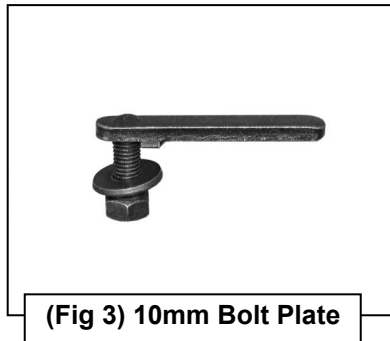

Fig 2

- (2) 8mm x 25mm Hex Bolts
- (2) 8mm Lock Washers
- (2) 8mm Flat Washers



(Fig 3) 10mm Bolt Plate

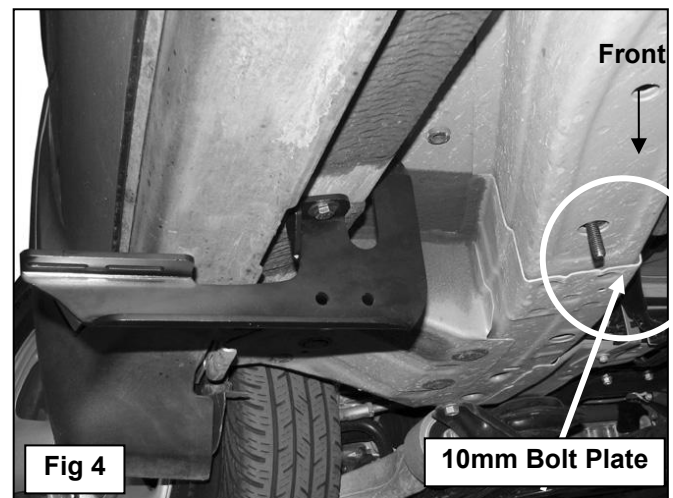

Fig 4

10mm Bolt Plate

- 10mm Flat Washer
- 10mm Lock Washer
- 10mm Hex Nut

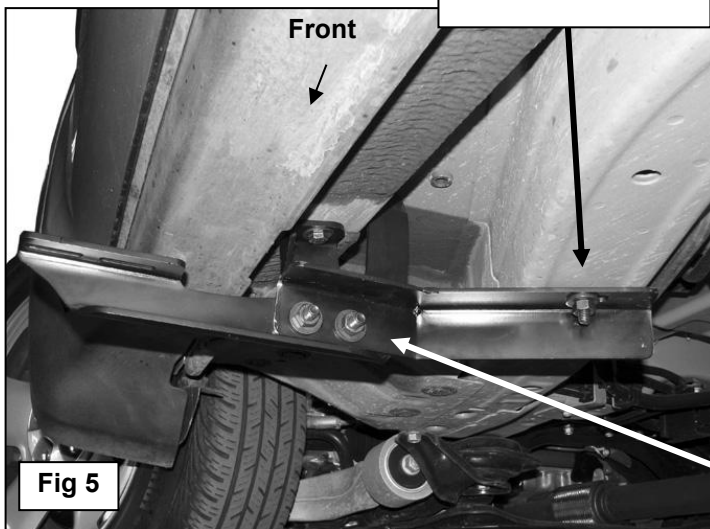
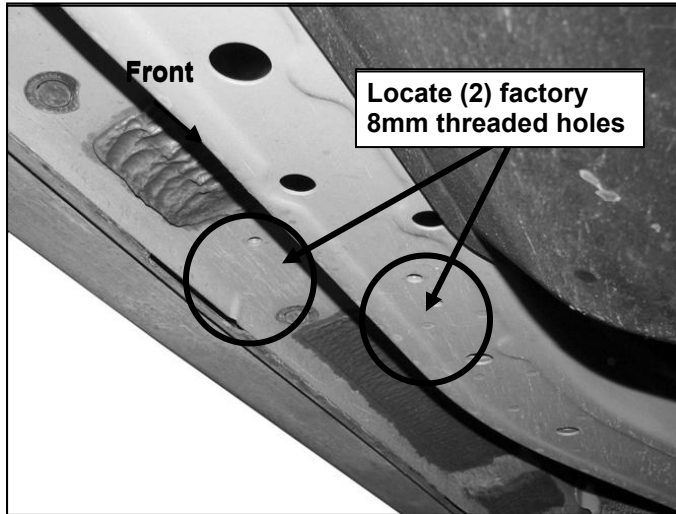

Fig 5

- (2) 10mm x 35mm Hex Bolts
- (4) 10mm Flat Washers
- (2) 10mm Lock Washers
- (2) 10mm Hex Nuts

Driver Side Installation Pictured



(Fig 6) Driver side center mounting location pictured

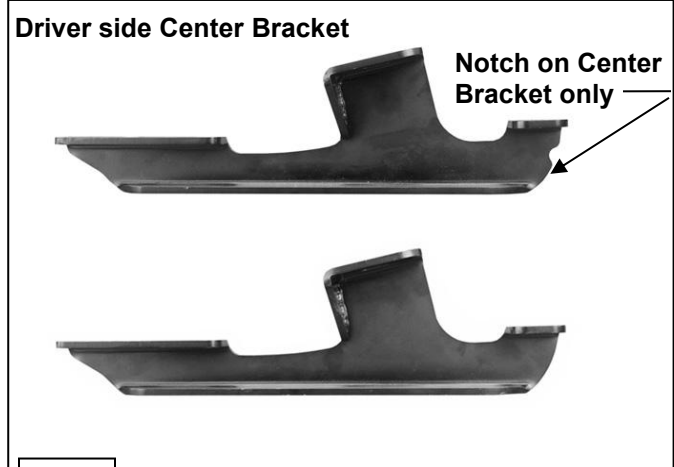
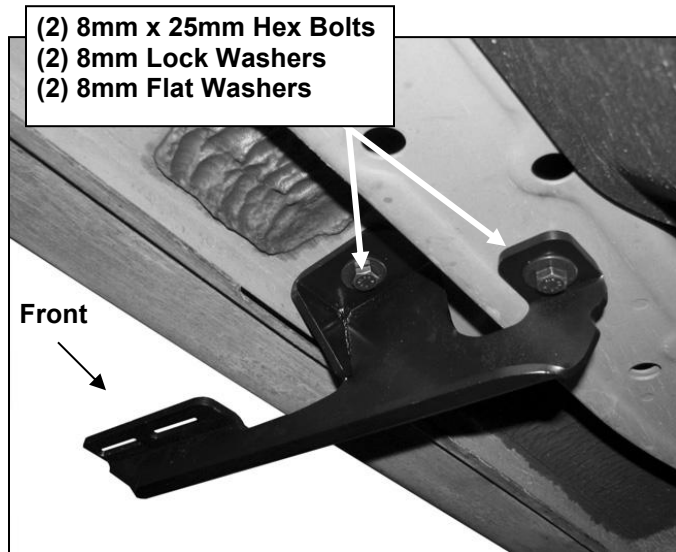
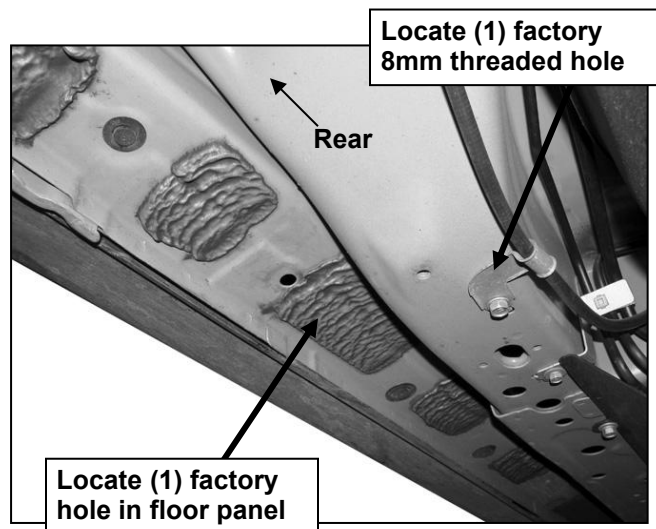

Fig 7

Driver side Rear Bracket



(Fig 8) Driver side Center Bracket installed



(Fig 9) Driver side rear mounting location pictured

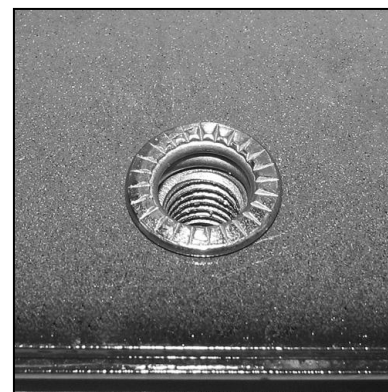
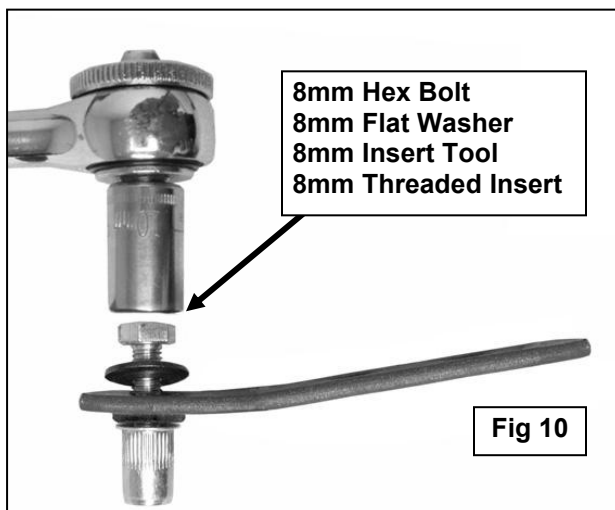

(Fig 11) Tighten Hex Bolt to collapse and lock Threaded Insert into factory hole

Driver Side Installation Pictured



(Fig 12) 8mm Threaded Insert fully installed

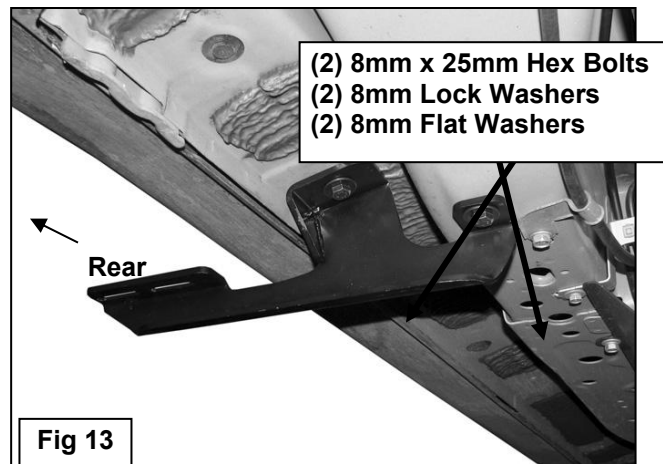

Fig 13

Slide M6 Square Hex Bolt
into slot at end of channel

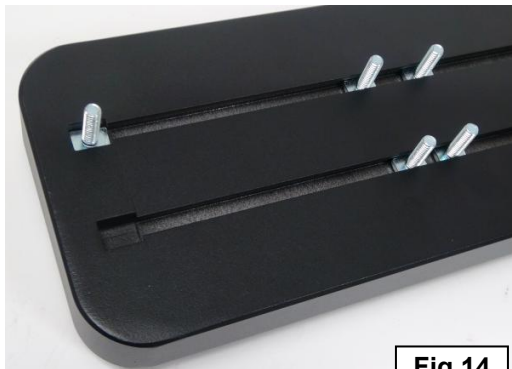
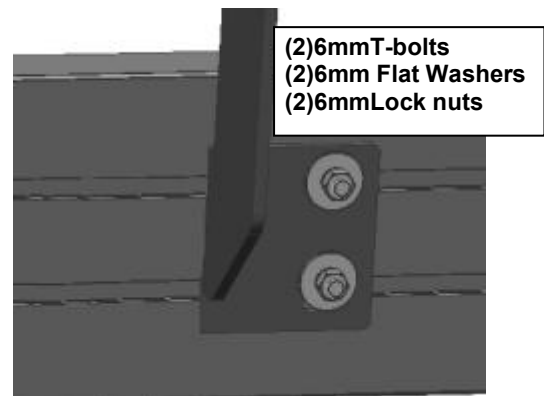

Fig 14



Fig 15

M6 Square Hex Bolt
M6 Nylon Lock Nuts
M6 Flat Washers



(2) 6mm T-bolts
(2) 6mm Flat Washers
(2) 6mm Lock nuts



Complete installation