

PARTS LIST:

Item	QTY	Description	Item	QTY	Description
#1	2	Running Board(use for left or right)	#9	24	1M0 x 1.5-30mm Hex Bolts
#2	4	Mounting Brackets (Front/Center)	#10	44	M10 Flat Washers
#3	1	Driver Rear Upper Mounting Bracket(DRM)	#11	28	M10 Lock Washers
#4	1	Passenger Rear Upper Mounting Bracket(PRM)	#12	16	M10 Hex Nuts
#5	1	Driver Rear Lower Mounting Bracket(DRB)	#13	4	M10X1.5 - 80 Hex Bolts
#6	1	Passenger Rear Lower Mounting Bracket(PRB)	#14	28	M6X1.0- 20 T-Bolts
#7	2	Front Bracket Spacers(DFS)	#15	28	M6 Flat Washers
#8	12	10mm Clip Nuts	#16	28	M6 Nylon Lock Nuts

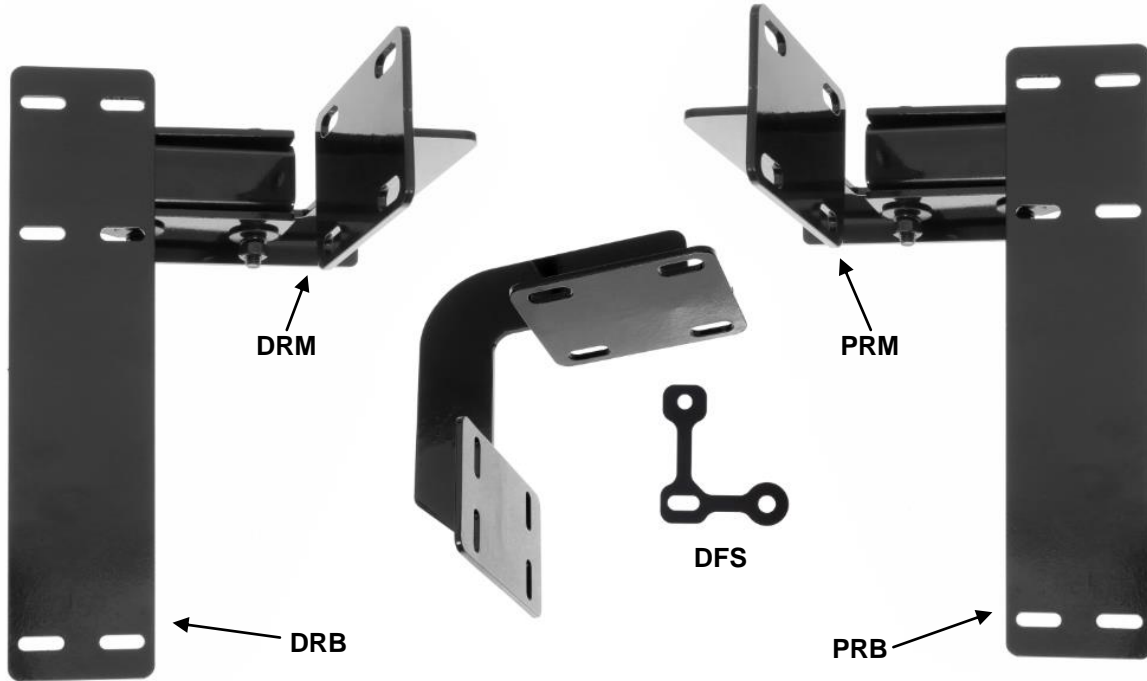

IMPORTANT ALERT: FOR WHEEL TO WHEEL APPLICATION, WEIGHT TO THE REAR END AREA OF THE RUNNING BOARD BEHIND THE LAST BRACKET NEED TO LESS THEN 130KG.OVERWEIGHT IN THIS AREA MAYBE DAMAGE YOUR RUNNING BOARD.

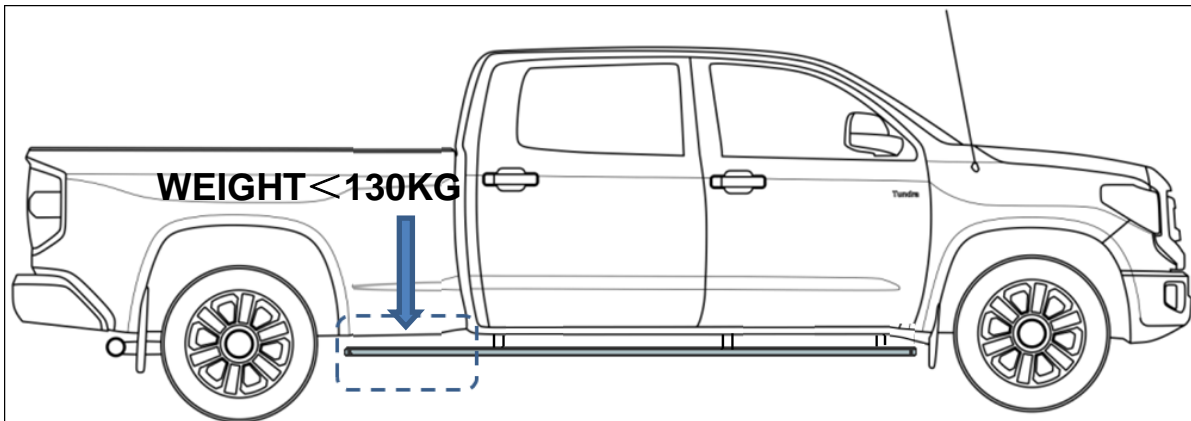

PROCEDURE:

1. **REMOVE CONTENTS FROM BOX. VERIFY ALL PARTS ARE PRESENT. READ INSTRUCTIONS CAREFULLY BEFORE STARTING INSTALLATION. ASSISTANCE IS RECOMMENDED. DRILLING IS OPTIONAL.**
2. Starting on the driver side-front of the vehicle, locate the front set of factory holes in the body panel and the (2) holes in the pinch weld under the front of the front door. **(Figures 1 & 2)**. Select (1) 10mm Clip Nut. Insert the Clip Nut into the rectangular opening and line up the threaded hole in the Clip with the round hole next to the opening. **NOTE:** Threaded nut must go towards the inside of the body panel, **(Figures 1 & 2)**.
3. Next, select (1) Front Bracket Spacer and (1) Mounting Bracket. Line up the (2) holes in the Spacer with the Clip Nut and (1) hole in the pinch weld, **(Figure 3)**. Insert (1) M10x30mm Hex Bolt, (1) M10 Lock Washer and (1) M10 Flat Washer through the top hole in the Bracket, the Spacer and into the Clip Nut. Leave hardware loose. Bolt the bottom of the Bracket to the pinch weld, (and Spacer), with the included (2) M10 x 30mm Hex Bolts, (2) M10 Lock Washers and (2) M10 Flat Washers, **(Figure 4)**. **NOTE:** Insert Hex Bolts in from the outside, through the pinch weld and then the Bracket. **IMPORTANT:** Cradles on the Mounting Brackets should face the front of the vehicle.
 - a. **OPTION:** The front Bracket installs with (3) Hex Bolts. If desired, a 4th mounting hole can be drilled through the body panel **(Figure 2)**. Use the Bracket as a template to determine the location to drill. Drill 3/8" if desired. Extra hardware has been provided.
4. Repeat **Steps 2 – 3** for Center Location Mounting Bracket installation. **NOTE:** Each mounting location is made up of a rectangular hole with a round hole on each side and two holes through the pinch weld, **(Figures 5 - 7)**.
NOTE:FRONT BRACKET AND CENTER BRACKET ARE UNIVERSAL.
5. Move to the rear location. Select a driver rear upper bracket, repeat **Step 4** to install the rear upper Mounting Bracket, **(Figure 7)**.Do not tighten hardware at this time.
6. Select the driver rear lower bracket, bolt to the upper bracket with (2)M10x80mm Hex bolts,(2)M10 lock washers,(4)M10 flat washers and (2)M10 Hex Nuts. **(Figure 8)** .Do not tighten hardware at this time.
7. Once all (3) Brackets have been installed, Select a Running Board. Slip (14) M6 T-Bolts into each bottom channel **(Figure 9)**.Carefully position the Running Board onto the Mounting Brackets. Attach the Running Board to the Front& Center Mounting Brackets with (4) M6 T-bolts,(4)M6 flat washers and (4)M6 Nylon lock nuts, to Rear bracket with (6) M6 T-bolts,(6)M6 flat washers and (6)M6 Nylon lock nuts **(Figure 10&11)**. Do not tighten hardware at this time
8. Level and adjust Running Board properly and tighten all hardware.
9. Repeat **Steps 2 – 7** for passenger Running installation.
10. Do periodic inspections to the installation to make sure that all hardware is secure and tight.

To protect your investment, wax this product after installing. Regular waxing is recommended to add a protective layer over the finish. Do not use any type of polish or wax that may contain abrasives that could damage the finish.

For Polished Finishes: Aluminum polish may be used to polish small scratches and scuffs on the finish. Mild soap may be used also to clean the Running Board.

For black finishes: Mild soap may be used to clean the Running Board.

Driver Side Installation Pictured

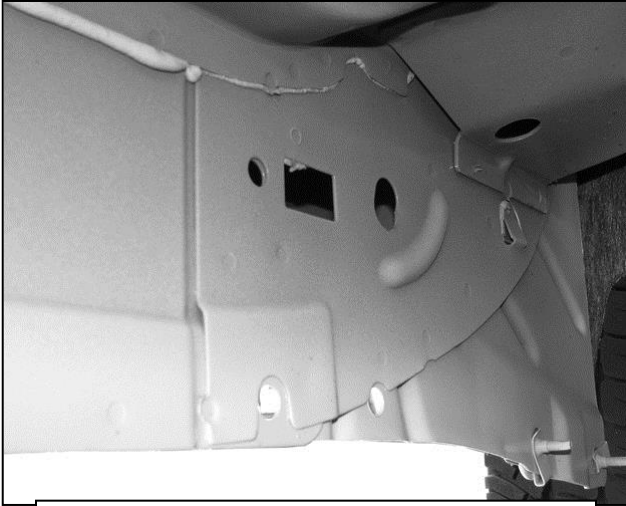

(Fig 1) Driver side front mounting location

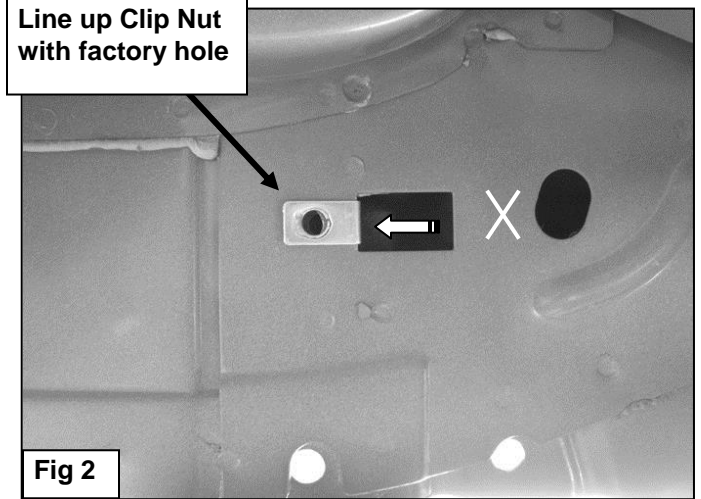
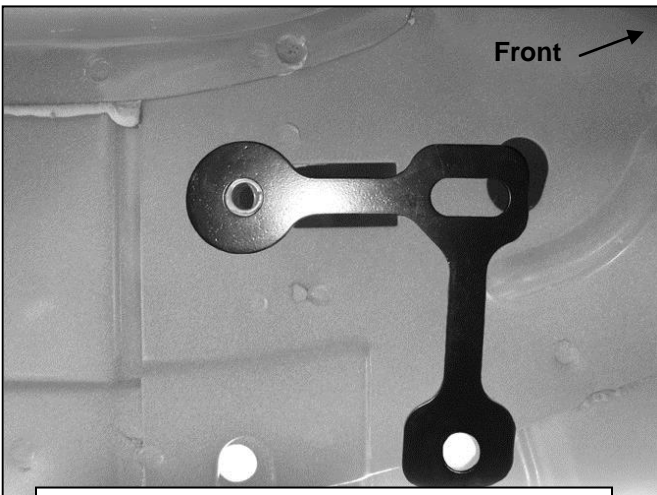

Fig 2



(Fig 3) Front Bracket Spacer on driver side

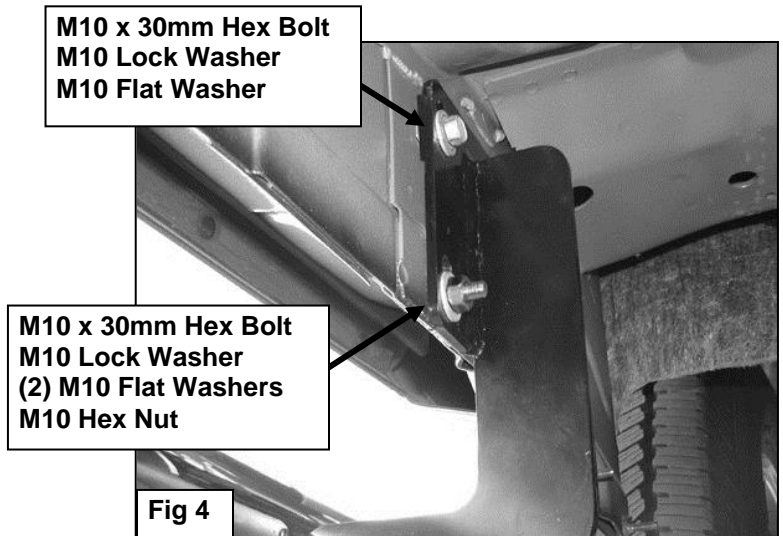
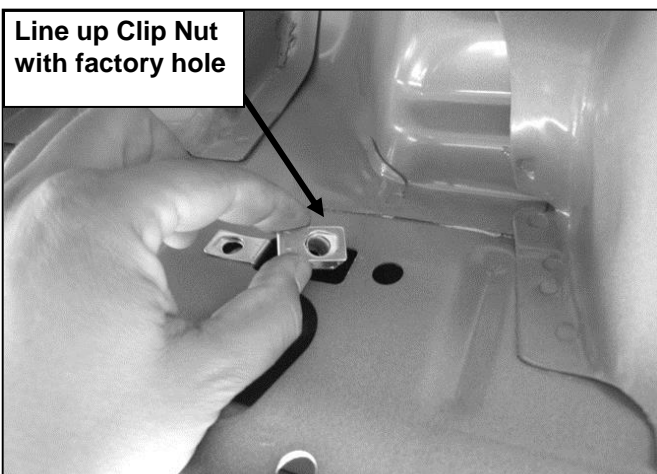

Fig 4



(Fig 5) Example center or rear mounting location

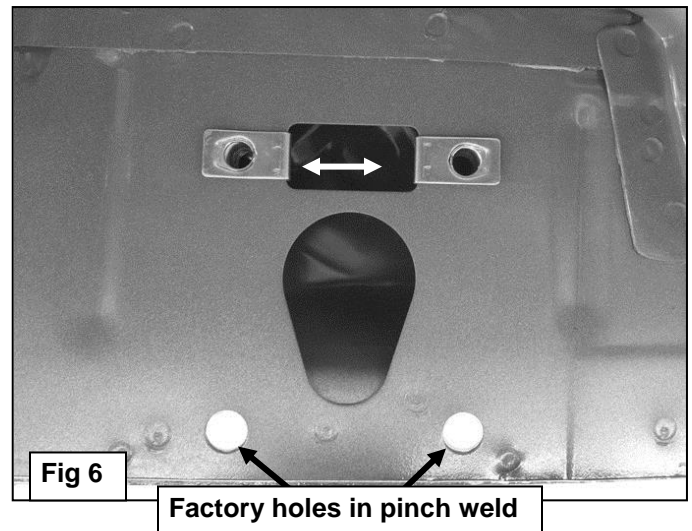
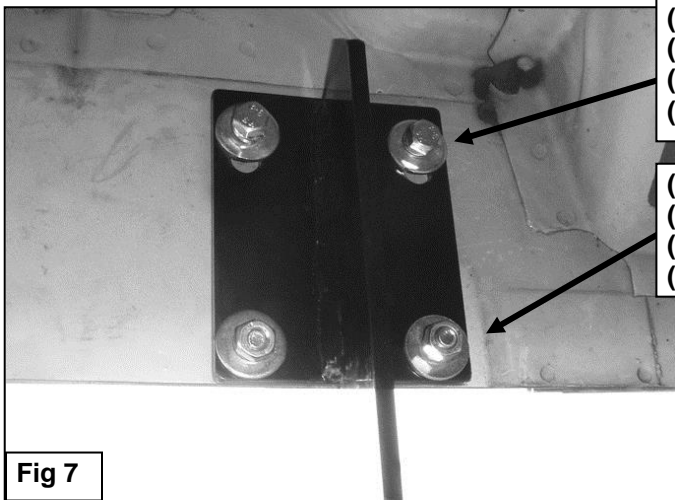

Fig 6

Factory holes in pinch weld



- (2) M10 Clip Nuts
- (2) M10 x 30mm Hex Bolts
- (2) M10 Lock Washers
- (2) M10 Flat Washers

- (2) M10 x 30mm Hex Bolts
- (4) M10 Flat Washers
- (2) M10 Lock Washers
- (2) M10 Hex Nuts

Fig 7

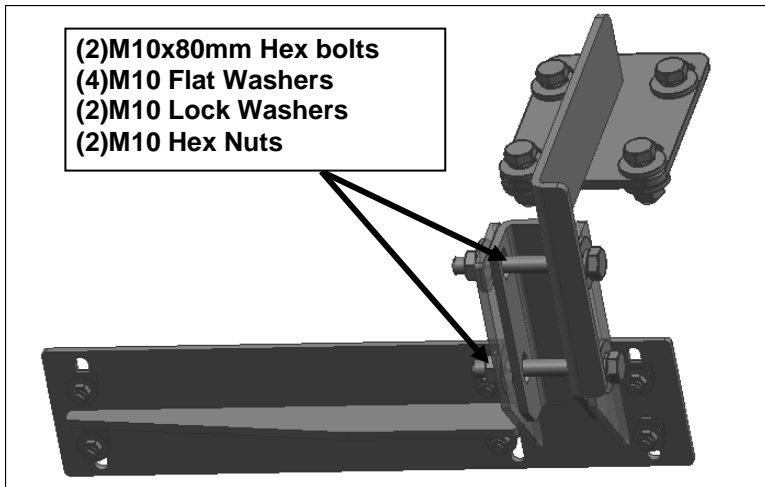

- (2)M10x80mm Hex bolts
- (4)M10 Flat Washers
- (2)M10 Lock Washers
- (2)M10 Hex Nuts



(Fig 9) Slip M6 T-bolts into the bottom channel

(Fig 8) Driver/Left rear Lower Mounting Bracket assembly

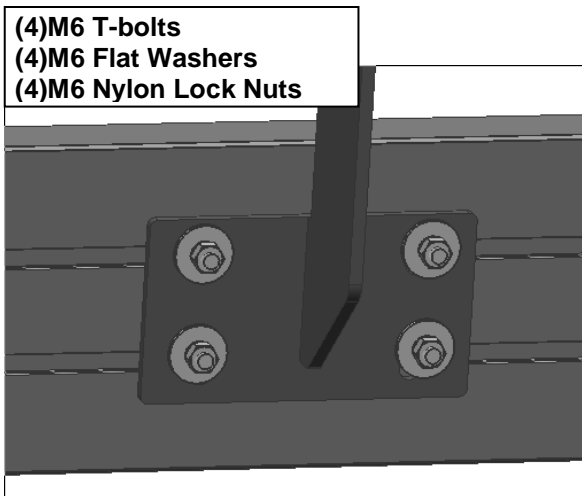

- (4)M6 T-bolts
- (4)M6 Flat Washers
- (4)M6 Nylon Lock Nuts

(Fig 10) Front/Center Bracket

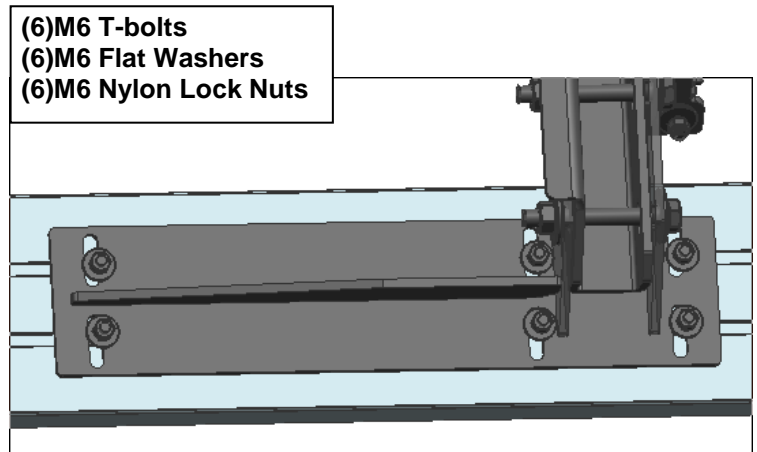

- (6)M6 T-bolts
- (6)M6 Flat Washers
- (6)M6 Nylon Lock Nuts

(Fig 11) Rear Bracket Installation