

PARTS LIST:

Item	QTY	Description	Item	QTY	Description
#1	2	Running Board(use for left or right)	#15	2	7/16"-20 x 1-3/4" Fine Thread Hex Bolts (Use for Rear Support Brackets Only)
#2	1	Driver/Left Front Frame Mounting Bracket(DFM)	#16	16	M12 Flat Washers
#3	1	Driver/Left Front Lower Mounting Bracket(DFB)	#17	10	M12 Lock Washers
#4	1	Passenger/Right Front Frame Mounting Bracket(PFM)	#18	6	M12 Hex Bolts
#5	1	Passenger/Right Front Lower Mounting Bracket(PFB)	#19	6	M12 Hex Nuts
#6	2	Rear Frame Mounting Brackets(DRS3)	#20	2	M10 Hex Bolts
#7	2	Rear Mounting Plates(DRS2)	#21	2	M8 Hex Bolts
#8	2	Rear Support Brackets(DRS1)	#22	4	M8 Flat Washers
#9	1	Driver/Left Rear Lower Mounting Bracket(DRB)	#23	2	M8 Lock Washers
#10	1	Passenger/Right Rear Lower Mounting Bracket(PRB)	#24	2	M8 Hex Nuts
#11	2	Φ 32 Spacer Tubes (Front)	#25	16	M6 Square Head Bolts
#12	2	7/16"-14 x 1-3/4" Coarse Thread Coupling Nuts (Use for Front Mounting Bracket Only)	#26	16	M6 Flat Washers
#13	2	7/16"-20 x 1-3/4" Fine Thread Coupling Nuts (Use for Rear Support Brackets Only)	#27	16	M6 Lock Nuts
#14	2	7/16"-14 x 1-3/4" Coarse Thread Hex Bolts (Use for Front Mounting Bracket Only)			

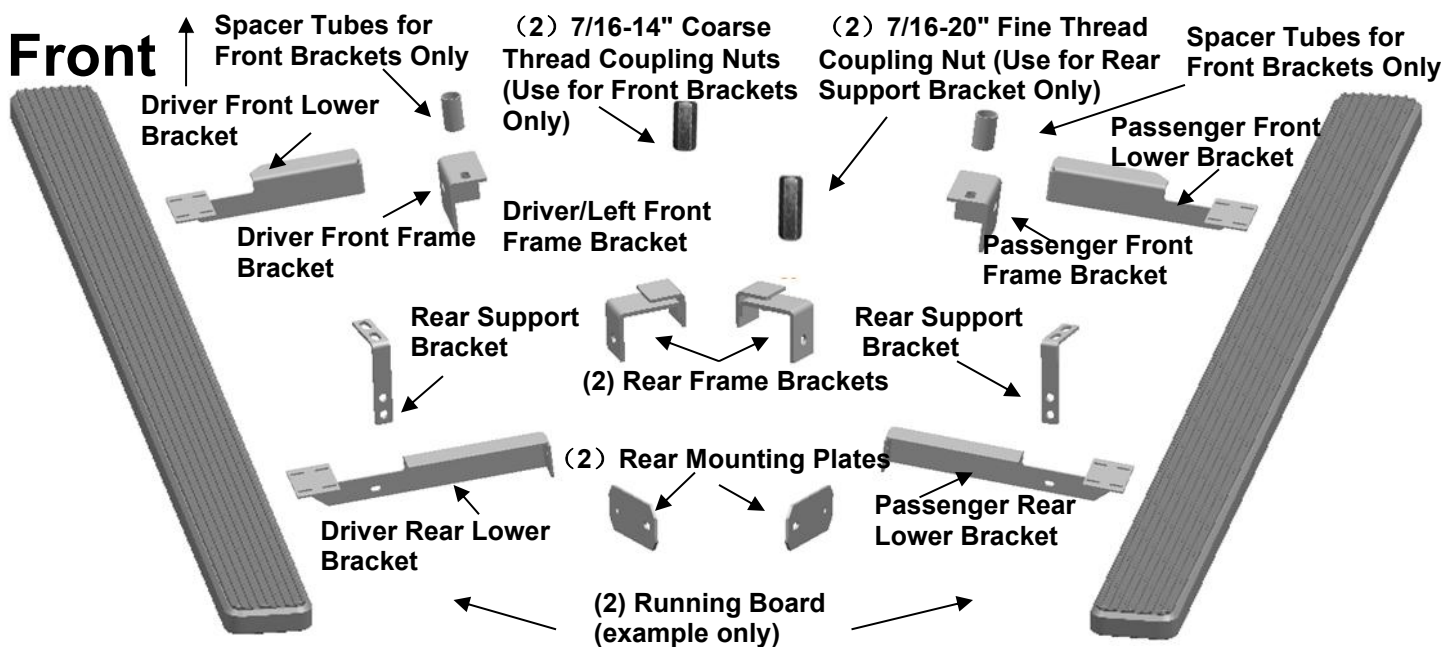

PROCEDURE:

REMOVE CONTENTS FROM BOX. VERIFY ALL PARTS ARE PRESENT. READ INSTRUCTIONS CAREFULLY BEFORE STARTING INSTALLATION. ASSISTANCE IS RECOMMENDED.

- Starting under the passenger side of the vehicle, locate the factory front body mount, (**Figure 1**). Select (1) 7/16-14 Coarse Thread Coupling Nut. **IMPORTANT:** The hardware kit includes (4) Coupling Nuts, (2) are 7/16"-14 coarse thread and (2) are 7/16"-20 fine thread. Verify that you have selected the coarse thread Coupling Nut or damage to the body mount bolt or

Coupling Nut may result. Thread the Coupling Nut onto the exposed end of the body mount bolt, **(Figure 2)**. Tighten hardware at this time.

2. Next, select the passenger side Front Frame Mounting Bracket and (1) Tube Spacer. Slide the Tube Spacer over the Coupling Nut, **(Figure 3)**. Hold the Front Mounting Bracket in position against the Coupling Nut and Spacer. Secure the Bracket to the Coupling Nut with (1) 7/16-14 x 1-3/4" Coarse Thread Hex Bolt, (1) 7/16" Flat Washer and (1) 7/16" Lock Washer.
IMPORTANT: Verify that you have selected the coarse thread 7/16-14 Hex Bolt or damage to the Coupling Nut may result. Do not tighten hardware at this time.
3. Select a passenger front lower bracket and bolt it to the upper bracket with (1)12mmx35mm Hex Bolt, (2)12mm Flat Washer,(1)12mm Lock Washer and(1)12mm Hex Nut **(Figure 3)**.
4. Move toward the rear of the vehicle. Select (1) Rear Frame Bracket. Thread (1) 10mm x 25mm Hex Bolt into the hex nut welded onto the Bracket. Slide the Bracket onto the bottom of the frame rail, **(Figure 4)**. Select (1) Rear Mounting Plate. Bolt the Mounting Plate to the Frame Bracket with(1)12mmx35mm Hex Bolt,(2)12mm Flat Washers,(1)12mm Lock Washer,(1)12mm Hex Nut**(Figure 5)**. Do not tighten hardware at this time.
5. Select a passenger rear lower bracket and attach to the rear mounting plate with (1)12mmx35 Hex Bolt,(2)12mm Flat Washers,(1)12mm Lock Washer,(1)12mm Hex Nut. **(Figure 8&9)**. Do not tighten hardware at this time.
6. Locate the exposed threaded end of the outer seat belt bolt in the bottom of the floor panel, **(Figure 6)**. Select (1) 7/16-20 Fine Thread Coupling Nut. Thread the Coupling Nut onto the threaded end of the seat belt bolt. Tighten the Coupling Nut. Select (1) Rear Support Bracket. Bolt the Support Bracket to the Coupling Nut with (1) 7/16"-20 x 1-3/4" Fine Thread Hex Bolt, (1) 7/16" Flat Washer and (1) 7/16" Lock Washer, **(Figure 7)**. Then bolt the support bracket to the rear lower bracket with(1)8mmx20 Hex Bolt,(2)8mm Flat Washers,(1)8mm Lock Washer and (1)8mm Hex Nut.**(Figure 9)**.**IMPORTANT:** Verify that you have selected the fine thread 7/16-20 Hex Bolt or damage to the Bolt or Coupling Nut may result. Do not tighten hardware at this time.
7. Select a Running Board. Slip(8) 6mm T-bolts into each bottom channel**(Figure 10)**. Carefully position the Running Board onto the (2) Mounting Brackets. **IMPORTANT:** Do not slide, (front to back), the Running Board on the Brackets or damage to the finish may result. Attach the Running Board to the Mounting Brackets with(4) 6mm T-bolts,(4)6mm flat washers and (4)6mm lock nuts **(Figures 11)**. Do not tighten at this time.
8. Level and adjust the running board and tighten all hardware.
9. Repeat steps 2-7 for driver running board installation.
10. Do periodic inspections to the installation to make sure that all hardware is secure and tight.

To protect your investment, wax this product after installing. Regular waxing is recommended to add a protective layer over the finish. Do not use any type of polish or wax that may contain abrasives that could damage the finish.

For Polished Finishes: Aluminum polish may be used to polish small scratches and scuffs on the finish. Mild soap may be used also to clean the Running Board.

For Black Finishes: Mild soap may be used to clean the Running Board.

PASSENGER SIDE INSTALLATION PICTURED

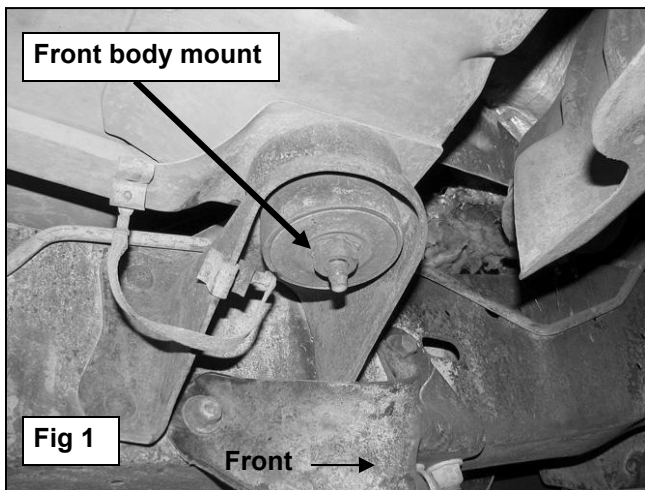

Thread the 7/16" – 14tpi
Coarse Thread Coupling Nut
onto threaded end of body bolt

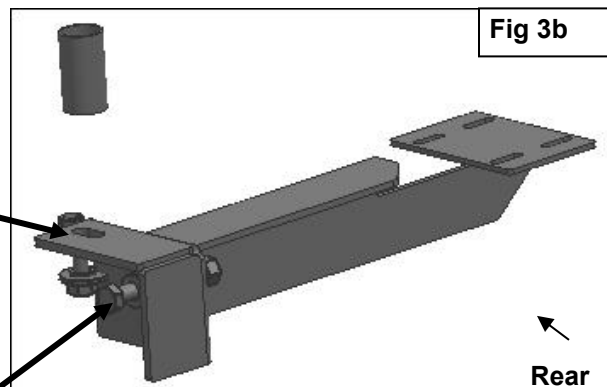
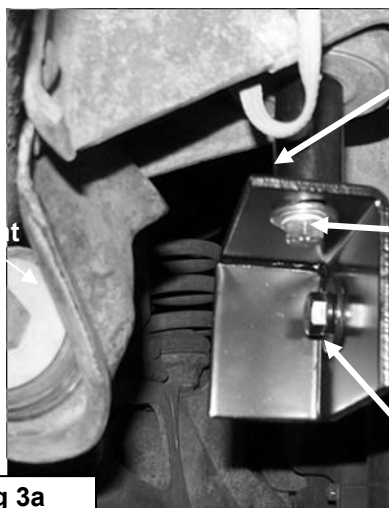
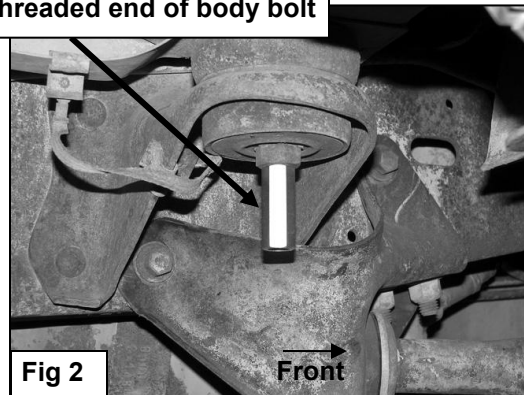

(1)12mmx35mm Hex Bolt
(2)12mm Flat Washers
(1)12mm Lock Washer
(1)12mm Hex Nut

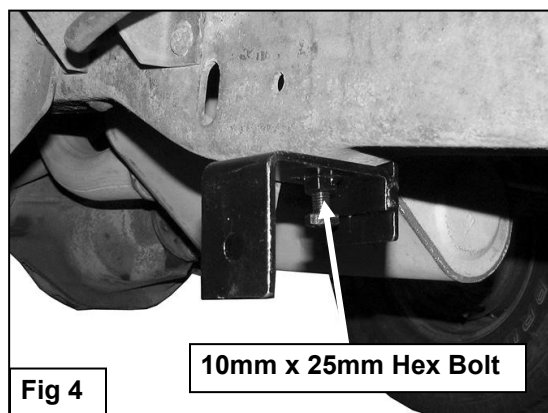

Loosen 10mm Locking Bolt in Frame Bracket to
slide Bracket Assembly forward or backward on
frame channel to line up with the end of the
Running Board. Once properly lined up, tighten
10mm Lock Bolt

PASSENGER SIDE INSTALLATION PICTURED

Thread the 7/16" – 20tpi Fine Thread Coupling Nut onto threaded end of seat belt bolt

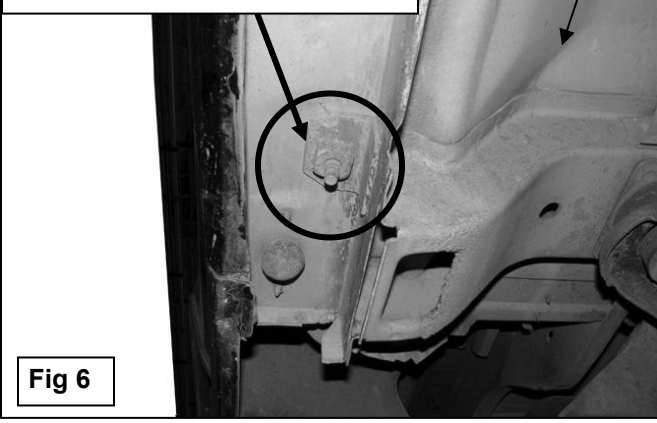
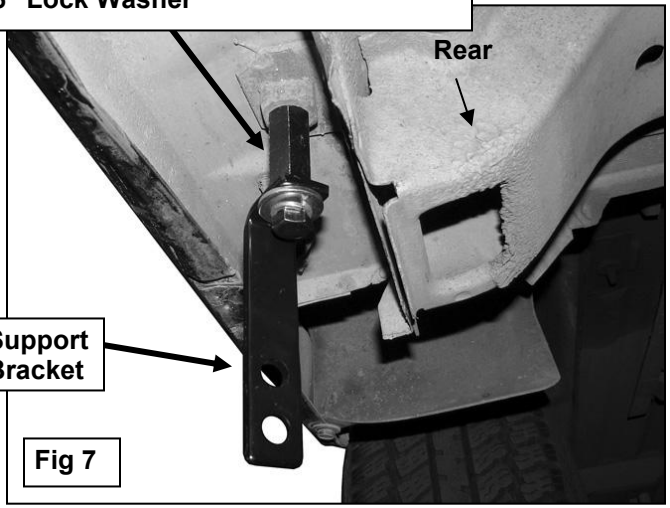

Fig 6

7/16" – 20 Fine Thread Coupling Nut
7/16" – 20 x 1-3/4" Fine Thread Hex Bolt
7/16" Flat Washer
7/16" Lock Washer



Support Bracket

Fig 7

(1)12mmx35 Hex Bolt
(2)12mm Flat Washers
(1)12mm Lock Washer
(1)12mm Hex Nut

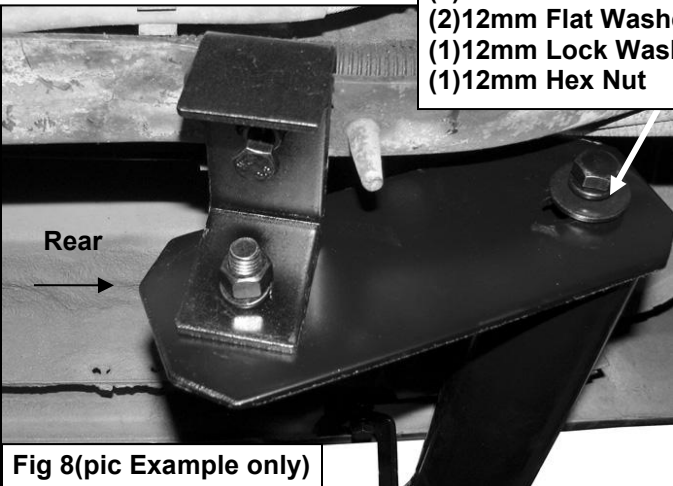
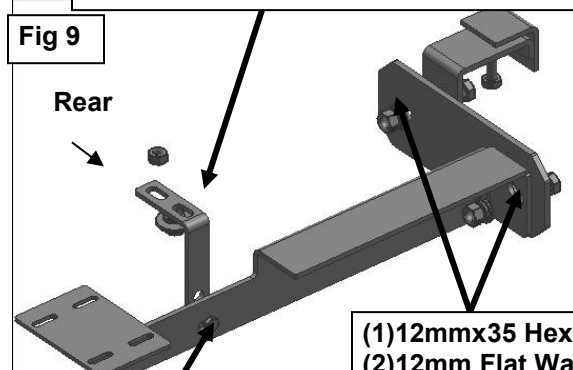

Fig 8(pic Example only)

7/16" – 20 Fine Thread Coupling Nut
7/16" – 20 x 1-3/4" Fine Thread Hex Bolt
7/16" Flat Washer
7/16" Lock Washer

Fig 9



Rear

(1)12mmx35 Hex Bolt
(2)12mm Flat Washers
(1)12mm Lock Washer
(1)12mm Hex Nut

(1)8mmx20 Hex Bolt
(2)8mm Flat Washers
(1)8mm Lock Washer
(1)8mm Hex Nut

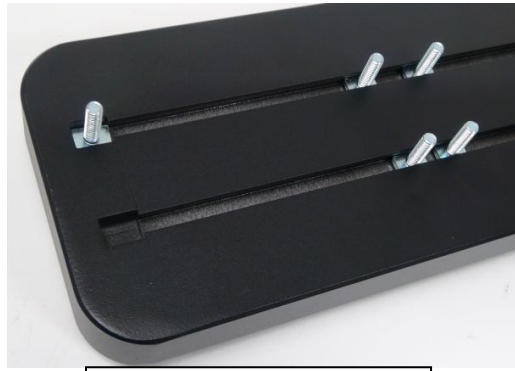

(Fig 10) Slip 6mm T-bolts into the bottom channel

(4)6mm T-bolts
(4)6mm Flat Washers
(4)6mm Lock nuts

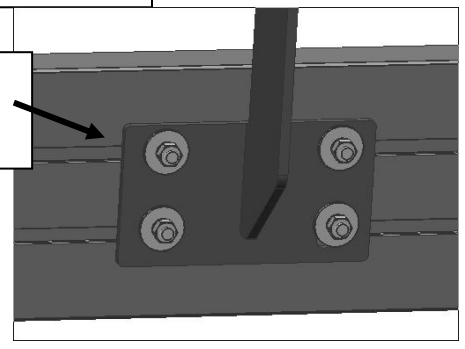

(Fig 11)Running Board Installation