

PARTS LIST:

Item	QTY	Description	Item	QTY	Description
#1	2	Running Board(use for left or right)	#8	20	8mm Flat Washers
#2	4	Front/Rear Mounting Brackets	#9	10	8mm Large Flat Washers
#3	1	Driver/Left Center Mounting Bracket	#10	20	8mm Lock Washers
#4	1	Passenger/Right Center Mounting Bracket	#11	10	8mm Hex Nuts
#5	10	8mm Deep Clip Nuts	#12	20	6-1.0mm x 20mm T-Bolts
#6	10	8-1.25mm x 30mm Hex Bolts	#13	20	6mm x 22mm OD x 2mm Flat Washers
#7	10	8-1.25mm x 25mm Hex Bolts	#14	20	6mm Lock Nuts

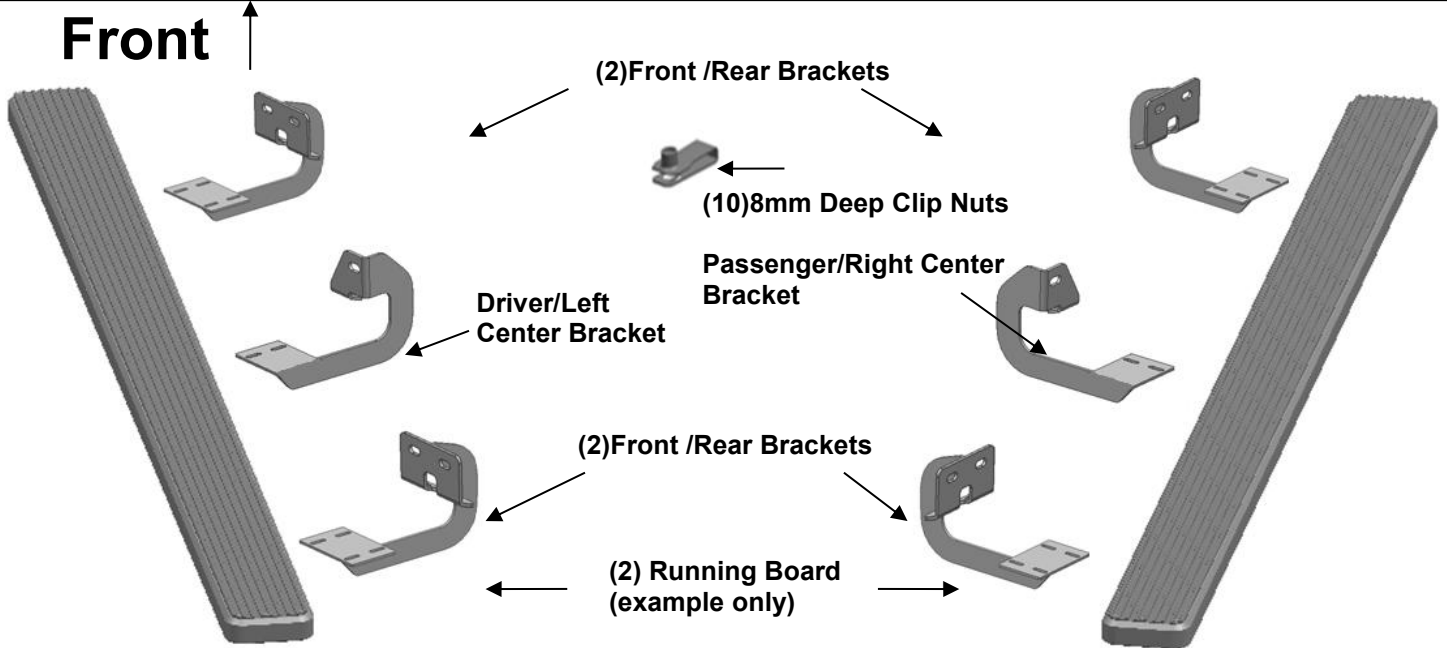

PROCEDURE:

- REMOVE CONTENTS FROM BOX. VERIFY ALL PARTS ARE PRESENT. READ INSTRUCTIONS CAREFULLY BEFORE STARTING INSTALLATION.**
- Starting on the driver side of the vehicle, locate the (2) holes in the bottom of the body panel, (pinch weld), toward the front tire, **(Figure 1)**. Next locate the rectangular opening and (2) small holes in the inner body panel directly above the holes in the pinch weld, **(Figures 1 & 2)**. **NOTE:** The holes in the inner panel may be covered with sealing tape or insulation.
- Slide (1) 8mm Clip Nut into the rectangular opening with the nut towards the inside. Line up the threaded nut on the clip with the round hole, **(Figure 2)**. Repeat to install the 2nd 8mm Clip Nut in remaining hole location.
- Select the front Bracket, Attach the Bracket to the (2) Clip Nuts with the included (2) 8mm x 30mm Hex Bolts, (2) 8mm Lock Washers and (2) 8mm x 28mm Large Flat Washers, **(Figures 3 & 4)**. Depending on model and year, the brake cable may be run on the inside or outside of the Bracket. Do not tighten hardware at this time. **NOTE:** The cradle on the front Bracket should face to the rear of the vehicle.
- Align the bottom holes in the front Bracket with the (2) holes in the pinch weld. Bolt the Bracket to the pinch weld using the included (2) 8mm x 25mm Hex Bolts, (4) 8mm STD Flat Washers, (2) 8mm Lock Washers and (2) 8mm Hex Nuts, **(Figures 3 & 4)**. **NOTE:** Insert the bolts up from the bottom of the pinch weld and through the Bracket.
- Next, move toward the center of the vehicle. Locate the (2) holes in the pinch weld similar to the front location, Insert (1) 8mm Clip Nut into the rectangular opening and up to the single small round hole in the body panel, **(Figure 5)**.
- Select the driver side center Mounting Bracket. **(Figure 6)**. Attach the Bracket to the Clip Nut with (1) 8mm x 30mm Hex Bolt, (1) 8mm Lock Washer and (1) 8mm x 28mm Large Flat Washer, **(Figures 7 & 8)**. Line up the hole in the Bracket with the hole in the pinch weld. Bolt the Bracket to the pinch weld with (1) 8mm x 25mm Hex Bolt, (2) 8mm STD Flat Washers, (1) 8mm Lock Washer and (1) 8mm Hex

Nut. Do not tighten hardware at this time. **NOTE:** The cradle on the center mounting Bracket will face the front of the vehicle.

8. Continue along the cab to the rear mounting location. Locate the last (2) mounting holes in the pinch weld towards the back of the cab, (**Figures 1**). Repeat **Steps 2—5** for rear mounting Bracket installation. **NOTE:** The cradle on the rear Bracket should face the front of the vehicle.
9. Select a Running Board. Slip(12) 6mm T-bolts into each bottom channel(**Figure 9**). Carefully position the Running Board onto the (3) Mounting Brackets. **IMPORTANT:** Do not slide, (front to back), the Running Board on the Brackets or damage to the finish may result. Attach the Running Board to the Mounting Brackets with(4) 6mm T-bolts,(4)6mm flat washers and (4)6mm lock nuts (**Figures 10**). Do not tighten at this time.
10. Level and adjust the Running Board and fully tighten all hardware.
11. Repeat **Steps 2—10** for passenger Running Board installation.
12. Do periodic inspections to the installation to make sure that all hardware is secure and tight.

To protect your investment, wax this product after installing. Regular waxing is recommended to add a protective layer over the finish. Do not use any type of polish or wax that may contain abrasives that could damage the finish.

For Polished Finishes: Aluminum polish may be used to polish small scratches and scuffs on the finish. Mild soap may be used also to clean the Running Board.

For Black Finishes: Mild soap may be used to clean the Running Board.

Driver Side Installation Pictured

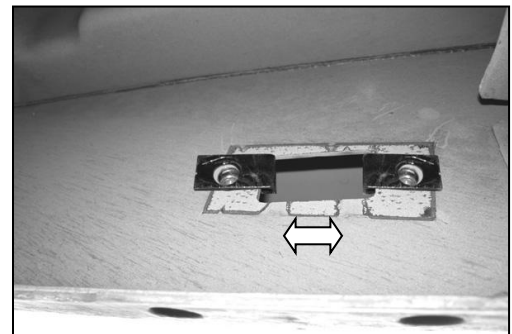
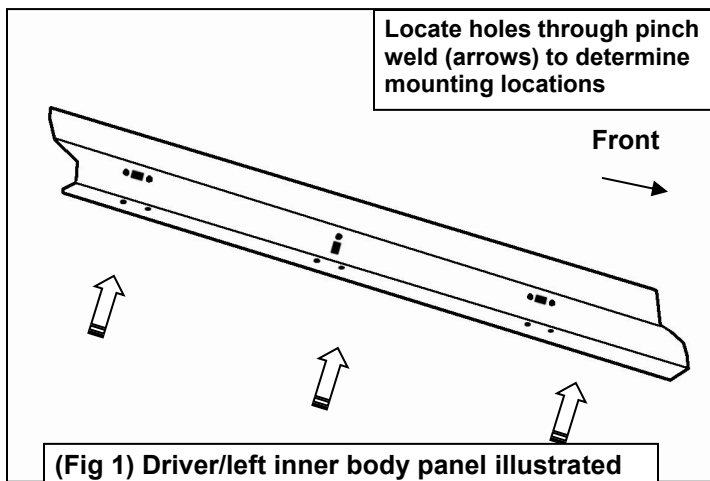

(Fig 3) Driver/left front mounting Bracket

- (2) 8mm x 25mm Hex Bolts
- (4) 8mm STD Flat Washers
- (2) 8mm Lock Washers
- (2) 8mm Hex Nuts

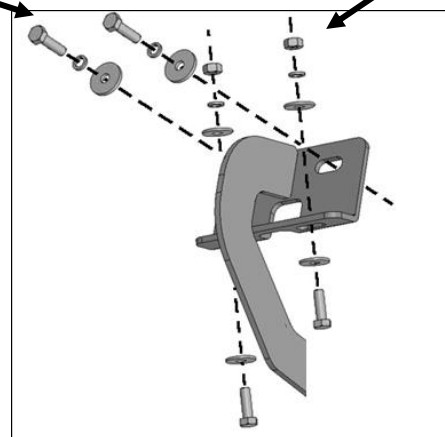

(Fig 4) Driver/left front mounting Bracket

Driver Side Installation Pictured

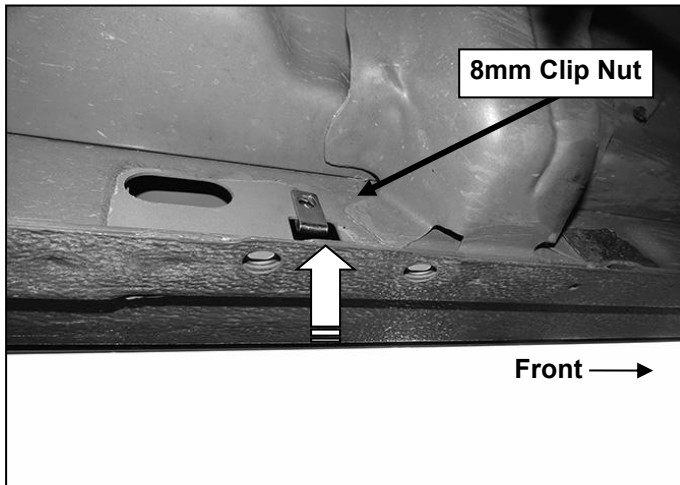

(Fig 5) Driver/left center mounting location pictured

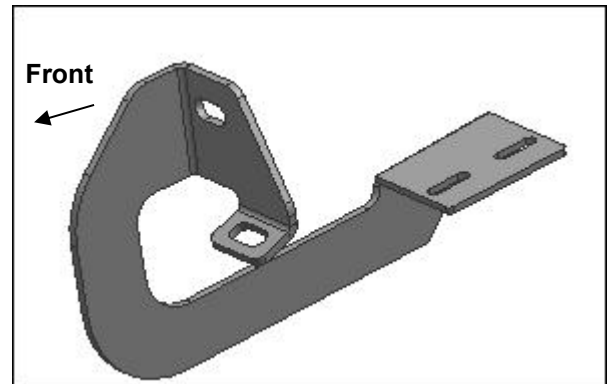

(Fig 6) Driver/left center Bracket

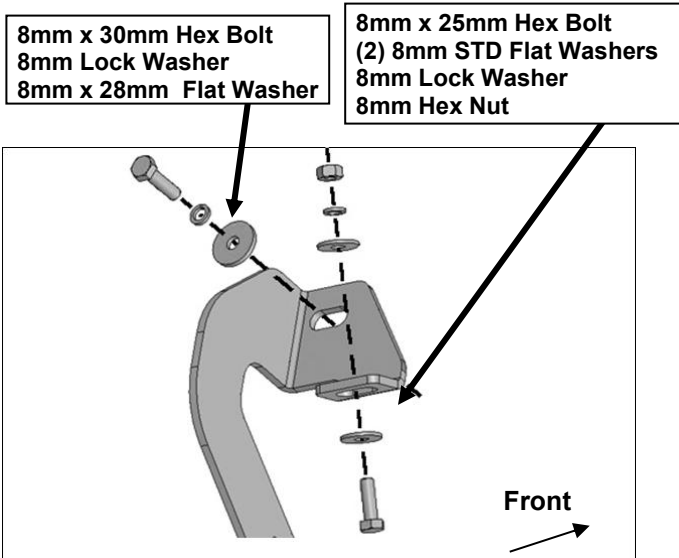

(Fig 7) Driver/left center Bracket

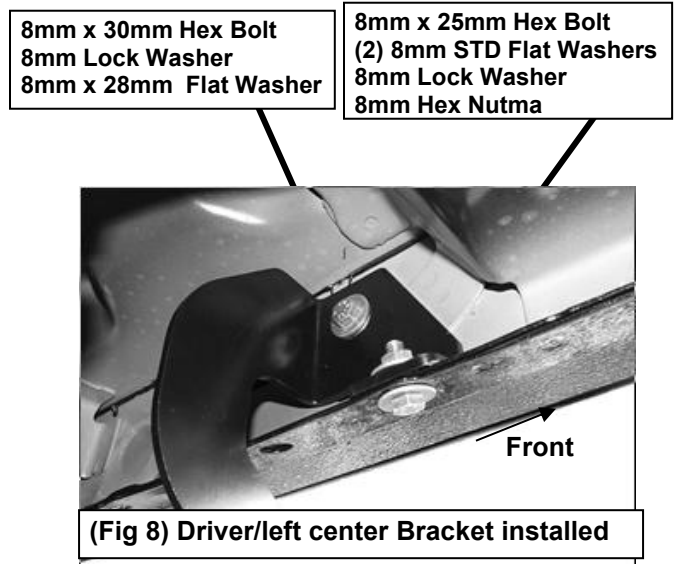

(Fig 8) Driver/left center Bracket installed



(Fig 9) Slip 6mm T-bolts into the bottom channel

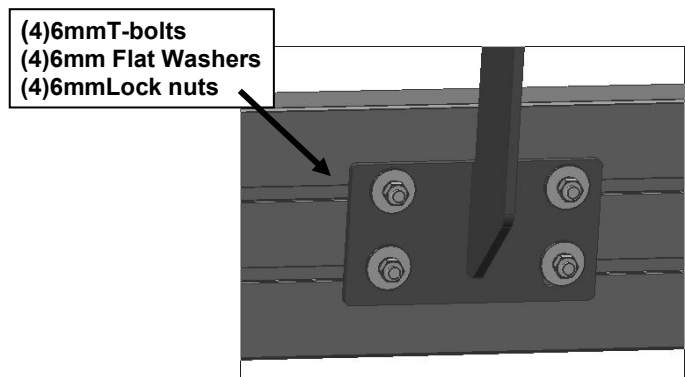

(Fig 10) Drive side Front/Rear Bracket Installation