

PARTS LIST:

Item	Qty	Description	Item	Qty	Description
#1	1	Driver/left Running Board	#15	2	10mm Lock Washers
#2	1	Passenger/right Running Board	#16	2	10mm Hex Nuts
#3	1	Driver/Left Side Front Bracket	#17	1	8mm Insert Tool
#4	1	Driver/Left Side Rear Bracket	#18	3	8-1.25mm Inserts
#5	1	Passenger/Right Side Front Bracket	#19	10	8-1.25mm Clip-Nuts
#6	1	Passenger/Right Side Center #2 Bracket	#20	1	8-1.25mm x 40mm Hex Bolt
#7	1	Passenger/Right Side Center #3 Bracket	#21	10	8-1.25mm x 25mm Hex Bolts
#8	2	Passenger/Right Side #4 & #5 Rear Brackets	#22	11	8mm x 24mm x 2mm Flat Washers
#9	2	12-1.75mm x 40mm Bolt Plates	#23	10	8mm Lock Washers
#10	2	10-1.5mm x 35mm Bolt Plates	#24	1	8mm Hex Nut
#11	2	12mm x 32mm OD x 3mm Flat Washers	#25	14	6-1.0mm x 20mm T-Bolts
#12	2	12mm Lock Washers	#26	14	6mm x 18mm OD x 1.6mm Flat Washers
#13	2	12mm Hex Nuts	#27	14	6mm Hex Nuts
#14	2	10mm x 30mm OD x 2.5mm Flat Washers			

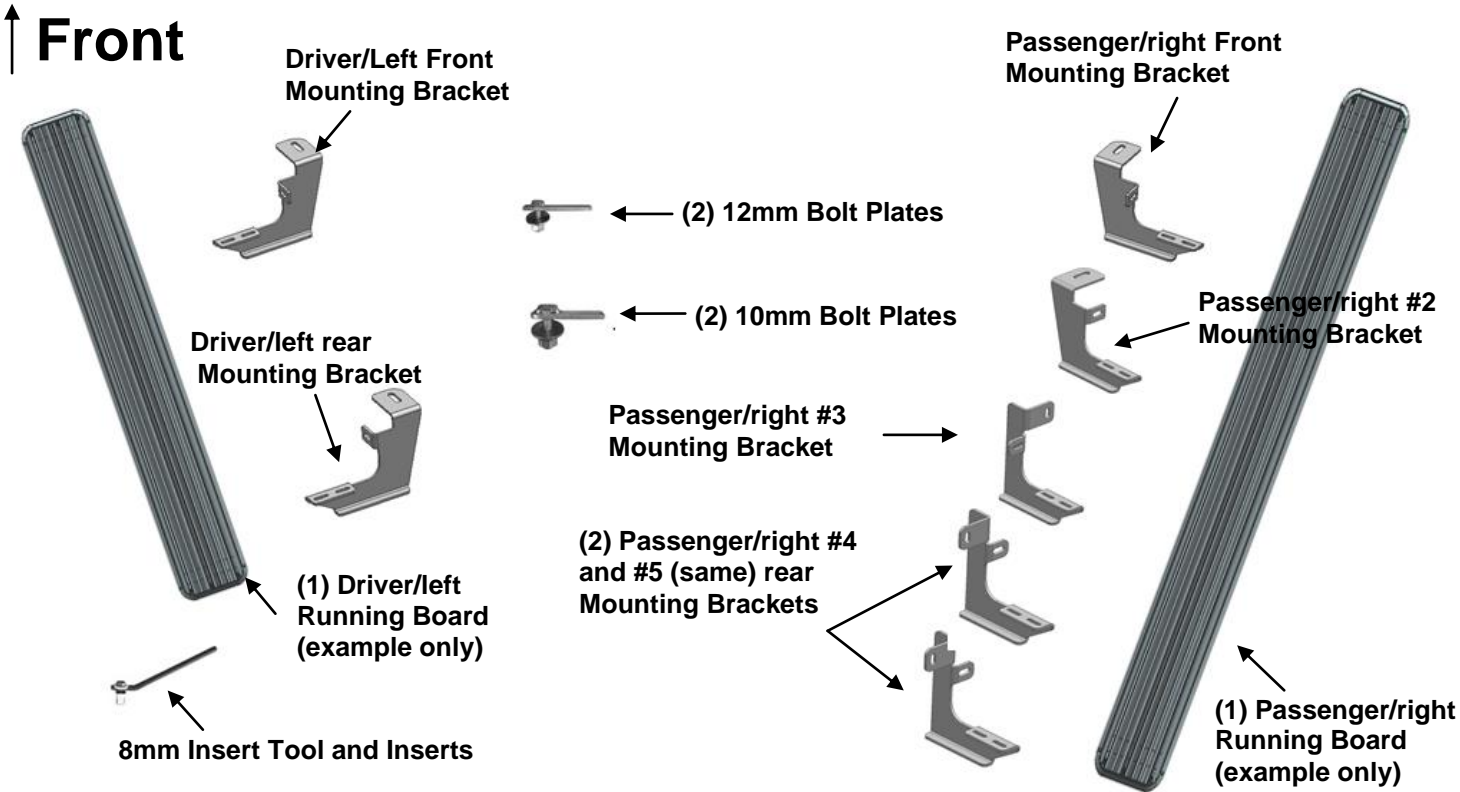

PROCEDURE:

REMOVE CONTENTS FROM BOX. VERIFY ALL PARTS ARE PRESENT. READ INSTRUCTIONS CAREFULLY BEFORE STARTING INSTALLATION.

1. Start the installation under the driver side of the vehicle. Locate and remove the rubber plug near the front tire opening, **(Figure 1)**. Select (1) 10mm Bolt Plate, **(Figure 2)**. Insert the Bolt Plate into and across the opening, **(Figures 3 and 10)**.

2. Select the driver side front Mounting Bracket, (**Figure 4**). Attach the Bracket to the Bolt Plate with (1) 10mm Flat Washer, (1) 10mm Lock Washer and (1) 10mm Hex Nut, (**Figure 5**). Leave hardware loose.
3. Line up the mounting tab on the Bracket with the factory hole in the pinch weld. Slide (1) 8mm Clip Nut over the hole in the pinch weld with the nut toward the outside of the vehicle, (**Figure 3**).

IMPORTANT: On some model/years, 5/16" holes will need to be drilled through the pinch weld to attach the tab on the Mounting Bracket to the pinch weld.

- a. Line up the tab on the Bracket with a flat area on the back of the pinch weld.
- b. Fully tighten the 10mm Hex Nut on the Bolt Plate. Use the tab on the Bracket for a guide and drill a 5/16" hole through the tab and the pinch weld.

IMPORTANT! Any cutting or drilling tool may break or shatter. Government regulations require safety glasses & equipment at all times when cutting or drilling.

- c. Slide (1) 8mm Clip Nut over the hole in the pinch weld with the nut toward the outside.
4. Attach the mounting tab on the Bracket to the 8mm Clip Nut with (1) 8mm x 25mm Hex Bolt, (1) 8mm Lock Washer and (1) 8mm Flat Washer, (**Figure 5**). Snug but do not fully tighten the hardware.
5. Move along the bottom of the body to the rear bracket location, (**Figure 7**). Locate and remove the large oval rubber plug. Insert (1) 12mm Bolt Plate into the opening, (**Figures 6 & 7**).
6. Attach the driver side rear Bracket to the Bolt Plate with (1) 12mm Flat Washer, (1) 12mm Lock Washer and (1) 12mm Hex Nut, (**Figures 8 & 9**). Repeat the appropriate **Steps 3 & 4** to attach the mounting tab on the Bracket to the back of the pinch weld.
7. Place the short driver side Running Board on top of the (2) Brackets. Slip (4) 6mm T-bolts into each bottom channel(**Figure 28**). Carefully position the Running Board onto the (2) Mounting Brackets.
IMPORTANT: Do not slide, (front to back), the Running Board on the Brackets or damage to the finish may result. Attach the Running Board to the Mounting Brackets with (2) 6mm T-bolts, (2)6mm flat washers and (2)6mm lock nuts (**Figures 29**). Do not tighten at this time.
8. Level and adjust the Running Board forward or backward as desired and fully tighten all hardware.
NOTE: Typical installation is with front of Board 2—3" back from front tire opening.
9. Move to the passenger side of the vehicle. Locate the rubber plug near the front tire opening, (**Figure 10**). Repeat **Steps 1—4** to install the passenger side Front Bracket, (**Figures 11 & 12**).
10. Continue along the body to the #2 Mounting Bracket location, (**Figure 13**). Repeat **Steps 5 & 6** to install the passenger side #2 Bracket, (**Figures 14 & 15**).
11. Move along the body to the #3 Bracket location below the side door, (**Figures 16 & 23**). Determine the correct procedure for your year/model for the remaining (3) passenger side Brackets:

Models with factory holes in pinch weld and inner body panel:

- a. Locate the factory hole in the pinch weld. Also locate the square hole and small round hole in the inner body panel near and above the hole in the pinch weld, (**Figure 16**). **NOTE:** Hold the appropriate Mounting Bracket up in each location to help determine the correct holes to use.
- b. Slide (1) 8mm Clip Nut into the square hole and in line with the smaller round hole. Next, slide (1) 8mm Clip Nut over the hole through the pinch weld as described in **Step 3, (Figure 16)**.
- c. Select the passenger side #3 Mounting Bracket, (**Figure 17**). Attach the Bracket to the (2) Clip Nuts with (2) 8mm x 25mm Hex Bolts, (2) 8mm Lock Washers and (2) 8mm Flat Washers, (**Figure 18**). Do not fully tighten hardware at this time.
- d. Repeat **Steps a—c** to install the #4, (**Figure 19—21**), and #5 rear, (**Figure 22**), Brackets, (#4 and #5 locations use the same Bracket).
- e. Skip to **Step 12**.

Models without factory holes in the pinch weld and/or inner body panel:

- a. Repeat **Step 7** to attach the Running Board to the front and #2 Mounting Brackets.
- b. Use a stand or a jack to hold the Running Board up and level with the front (2) Brackets.
- c. Select the #3 passenger side Bracket, (**Figure 17**). With the Running Board level to the vehicle, hold the Bracket up in position against the back of the pinch weld and body panel. Mark the location of the slots in the Bracket onto the sheet metal, (**Figure 23**). **NOTE:** Use a clamp or locking pliers to temporarily attach the Bracket to the pinch weld.
- d. Drill a 7/16" hole in the center of the mark for the top mounting tab. **IMPORTANT:** Make sure the Running Board is level to the vehicle before drilling any mounting holes.

- e. Select the 8mm Threaded Insert Tool, (1) 8mm x 40mm Hex Bolt, (1) 8mm Flat Washer and (1) 8mm Threaded Insert. Assemble the Insert as pictured in **Figure 26**
 - f. Firmly hold the handle and push the Insert into the hole. Use a small hammer to gently tap the insert into the hole if necessary. Once inserted, hold the handle with one hand and turn the 8mm Hex Bolt, (tighten), with a wrench to expand the insert in the body panel. Continue to tighten the hex bolt until the insert is fully compressed and close to flush with the surface. Remove bolt and tool from the insert, (**Figure 27**). **WARNING:** Do not overtighten the hex bolt or the insert may become damaged.
 - g. Repeat **Step 3** to drill the 5/16" hole through the pinch weld as needed.
 - h. Select the passenger side #3 Mounting Bracket. Attach the Bracket to the Insert and Clip Nut with (2) 8mm x 25mm Hex Bolts, (2) 8mm Lock Washers and (2) 8mm Flat Washers, (**Figure 18**). Do not fully tighten hardware at this time.
 - i. Repeat **Steps a—h** to install the identical #4 and #5 Brackets, (**Figures 20, 21, 24, 25**).
12. Place the long passenger side Running Board on top of the (**5**) Brackets. Slip (**10**) 6mm T-bolts into each bottom channel (**Figure 28**). Carefully position the Running Board onto the (**5**) Mounting Brackets. **IMPORTANT:** Do not slide, (front to back), the Running Board on the Brackets or damage to the finish may result. Attach the Running Board to the Mounting Brackets with (**2**) 6mm T-bolts, (**2**) 6mm flat washers and (**2**) 6mm lock nuts (**Figures 29**). Do not tighten at this time.
 13. Level and adjust the Running Board forward or backward as desired to match driver side and fully tighten all hardware, (**Step 8**).
 14. Do periodic inspections to the installation to make sure that all hardware is secure and tight.

To protect your investment, wax this product after installing. Regular waxing is recommended to add a protective layer over the finish. Do not use any type of polish or wax that may contain abrasives that could damage the finish.

For Polished Finishes: Aluminum polish may be used to polish small scratches and scuffs on the finish. Mild soap may be used also to clean the Running Board.

For black finishes: Mild soap may be used to clean the Running Board.

Driver/left Side Installation Pictured

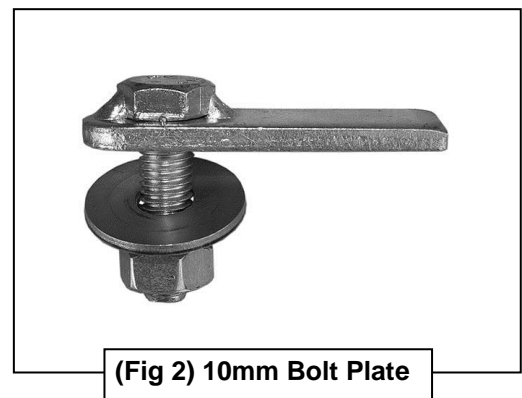
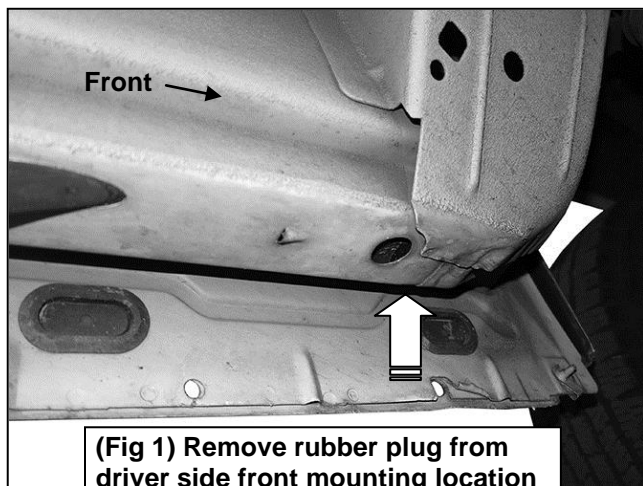

Driver/Left Side Installation Pictured

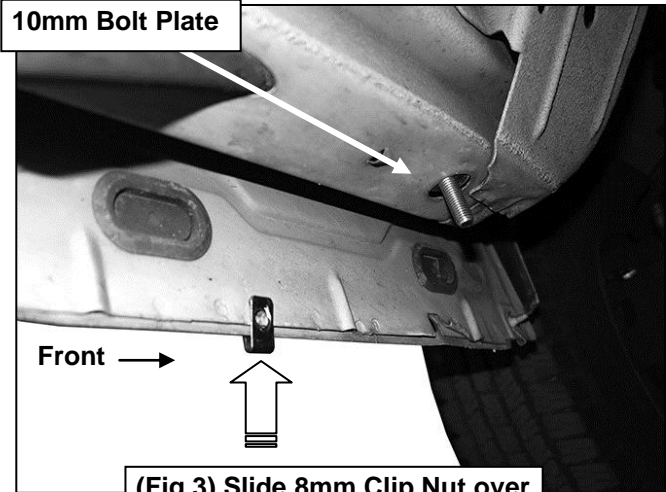

(Fig 3) Slide 8mm Clip Nut over factory hole in pinch weld

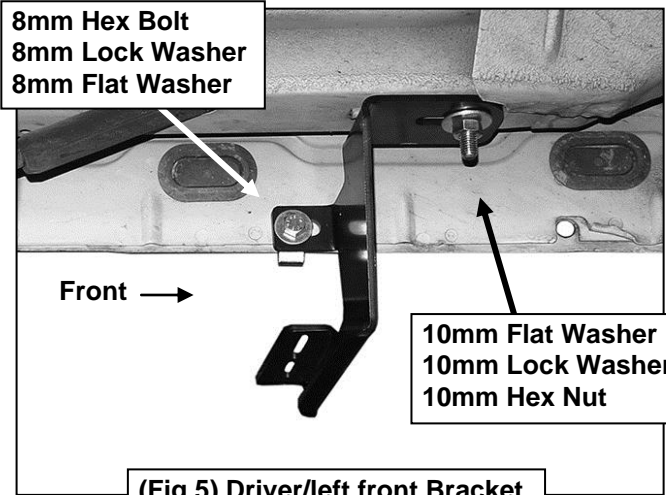

(Fig 5) Driver/left front Bracket

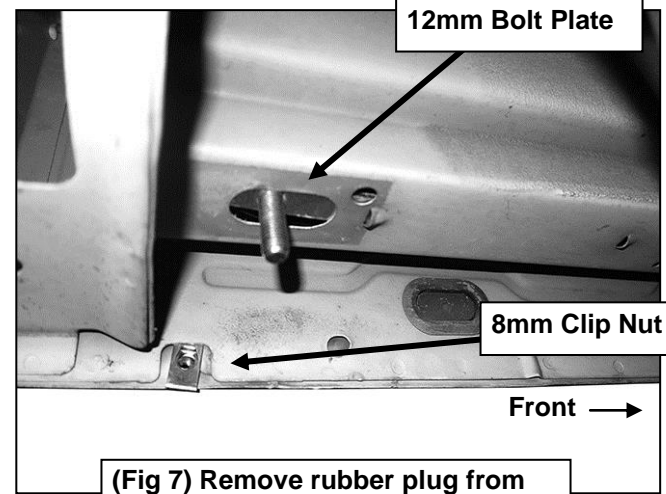

(Fig 7) Remove rubber plug from driver side rear mounting location

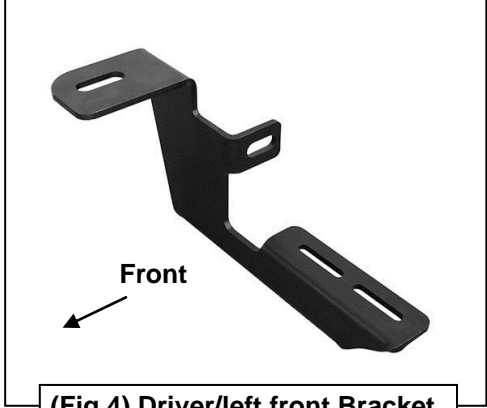

(Fig 4) Driver/left front Bracket

IMPORTANT: On some model/years, 5/16" holes will need to be drilled through the pinch weld to attach the tab on the Mounting Bracket to the pinch weld. Attach the Brackets to the Bolt Plates first, temporarily install the Running Board, and make sure Board is level then mark holes before drilling holes through pinch weld. Repeat for all Bracket installations

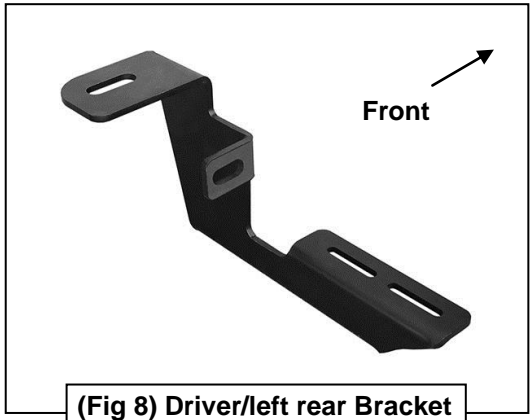
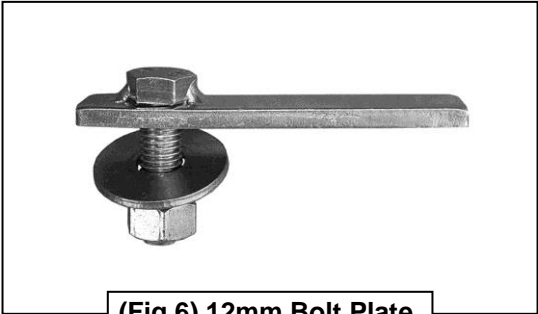

(Fig 8) Driver/left rear Bracket

Driver/Left side installation pictured

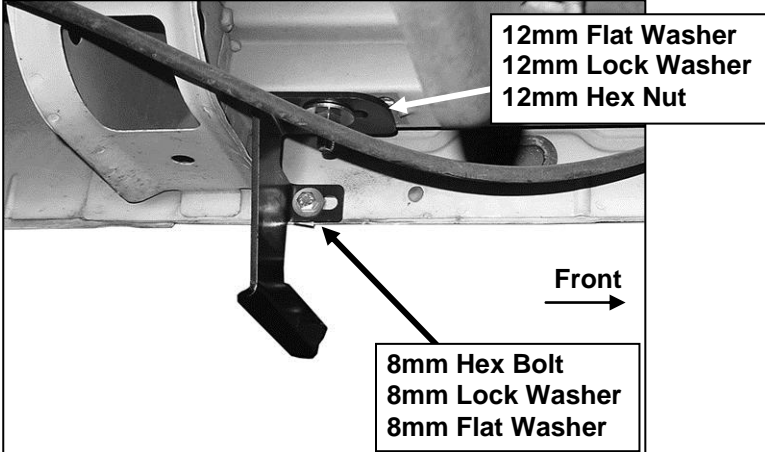

(Fig 9) Driver/left side rear Bracket installation

Passenger/right side installation pictured

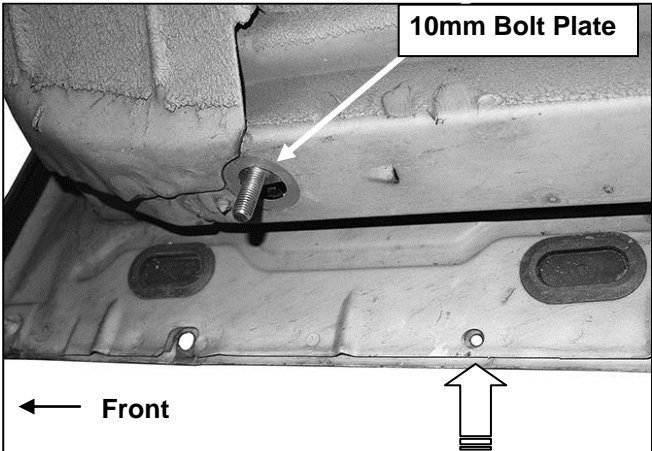

(Fig 10) Passenger/right front location pictured. Slide 8mm Clip Nut over factory hole in pinch weld

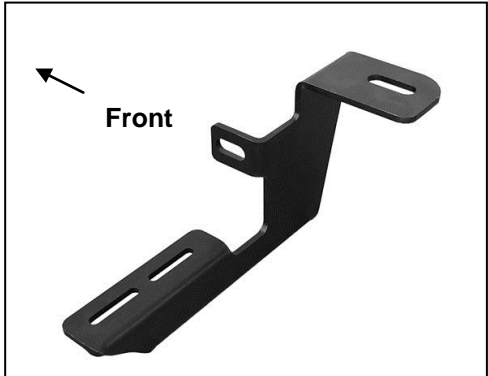

(Fig 11) Passenger/right front Bracket

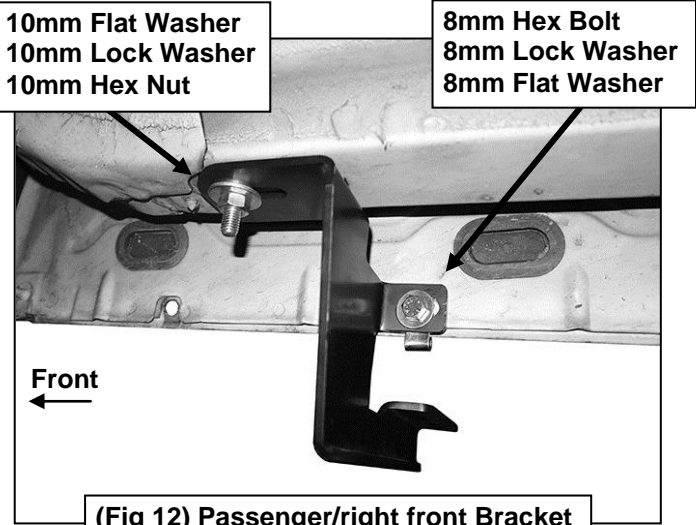

(Fig 12) Passenger/right front Bracket

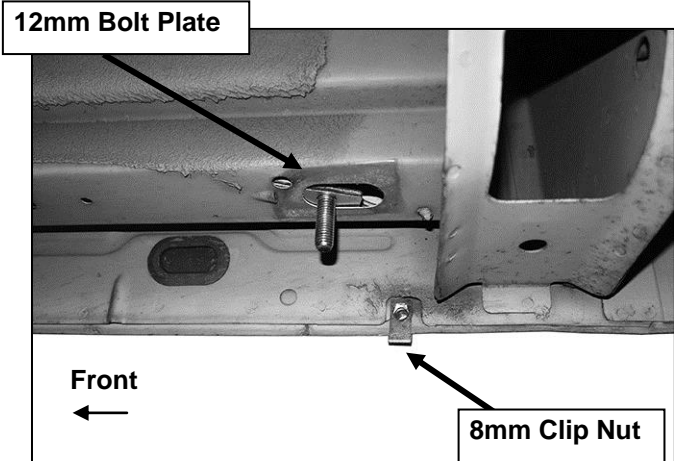

(Fig 13) passenger side #2 mounting location

Passenger/right side installation pictured

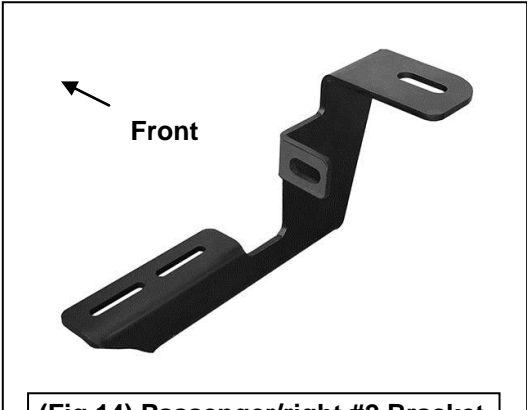

(Fig 14) Passenger/right #2 Bracket

8mm Hex Bolt
8mm Lock Washer
8mm Flat Washer

12mm Flat Washer
12mm Lock Washer
12mm Hex Nut

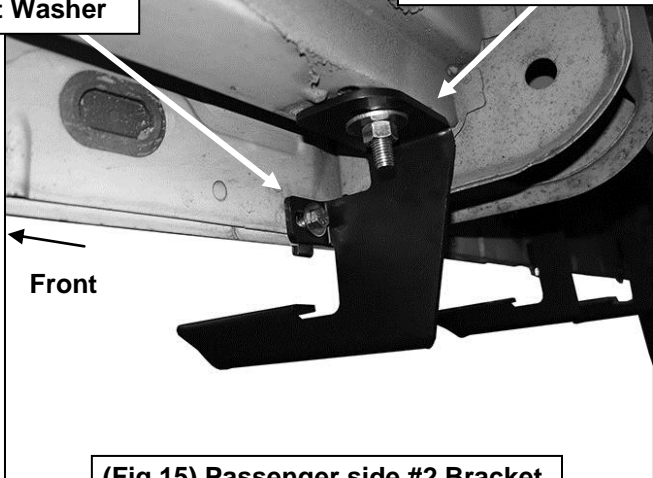

(Fig 15) Passenger side #2 Bracket

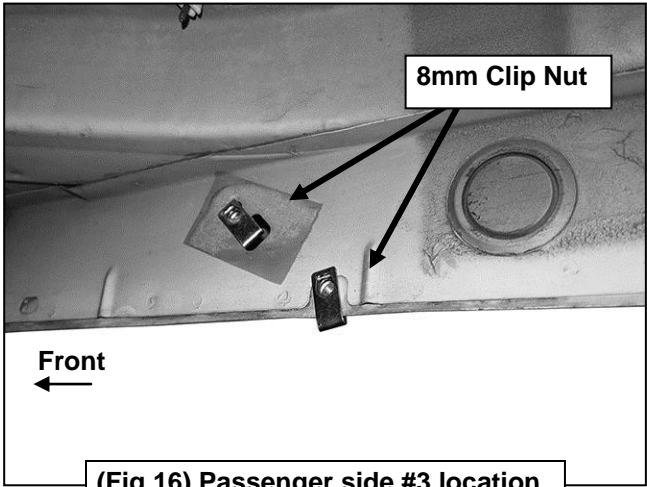

(Fig 16) Passenger side #3 location

IMPORTANT: On some model/years, 5/16" holes will need to be drilled through the pinch weld (see above) to attach the tab on the Mounting Bracket to the pinch weld. Attach the Brackets to the Bolt Plates first, temporarily install the Running Board, and make sure Board is level then mark holes before drilling holes through pinch weld. Repeat for all Bracket installations

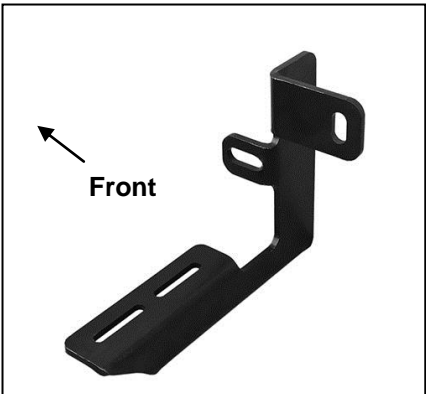

(Fig 17) Passenger side #3 Bracket

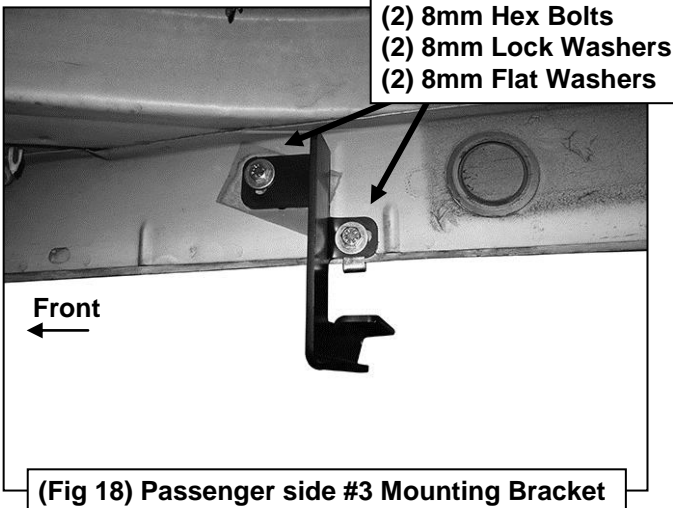

(Fig 18) Passenger side #3 Mounting Bracket

Passenger/right side installation pictured

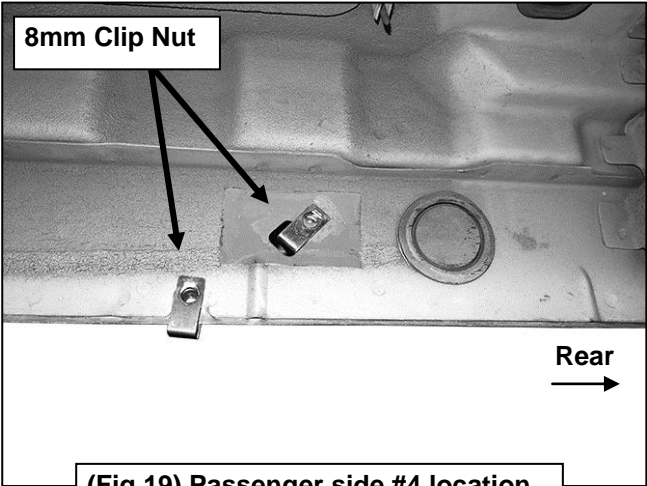

(Fig 19) Passenger side #4 location



(Fig 20) Passenger side #4 Bracket

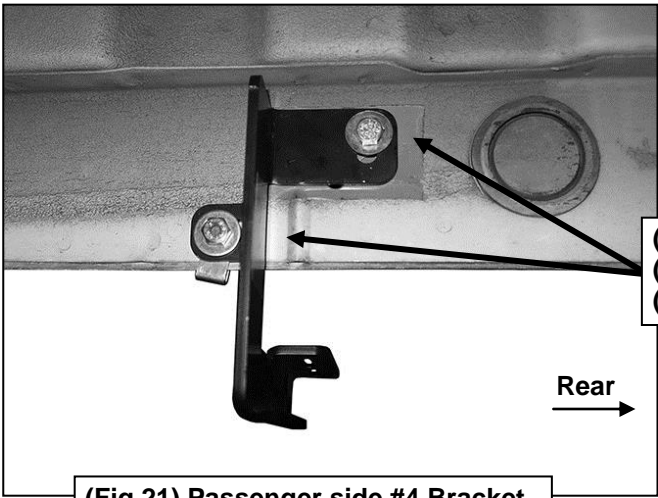

(Fig 21) Passenger side #4 Bracket

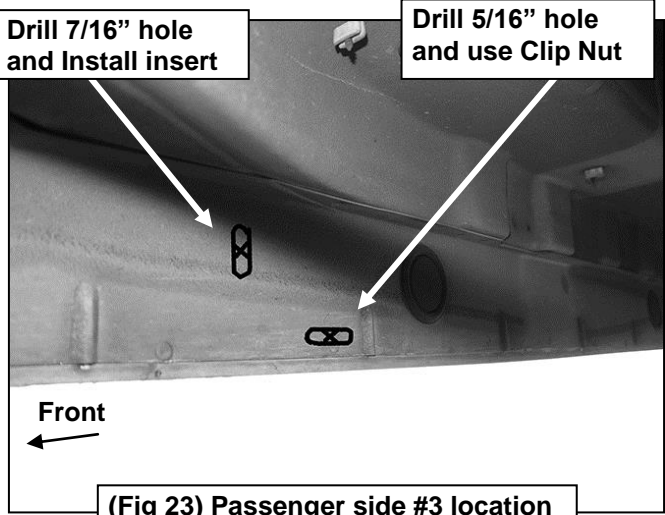

(Fig 23) Passenger side #3 location

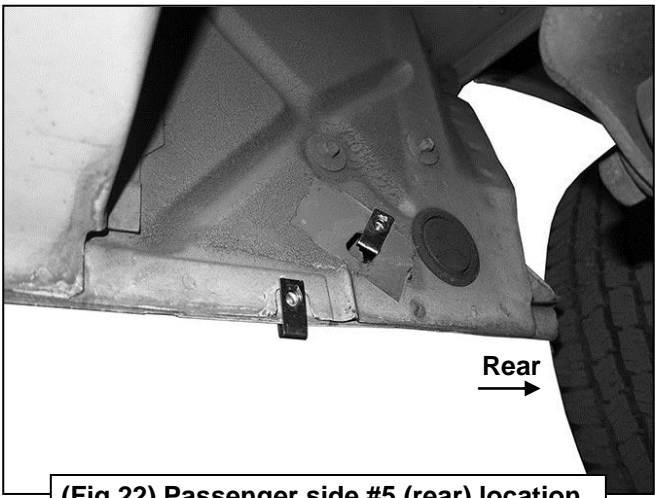

(Fig 22) Passenger side #5 (rear) location

Passenger/right side installation pictured

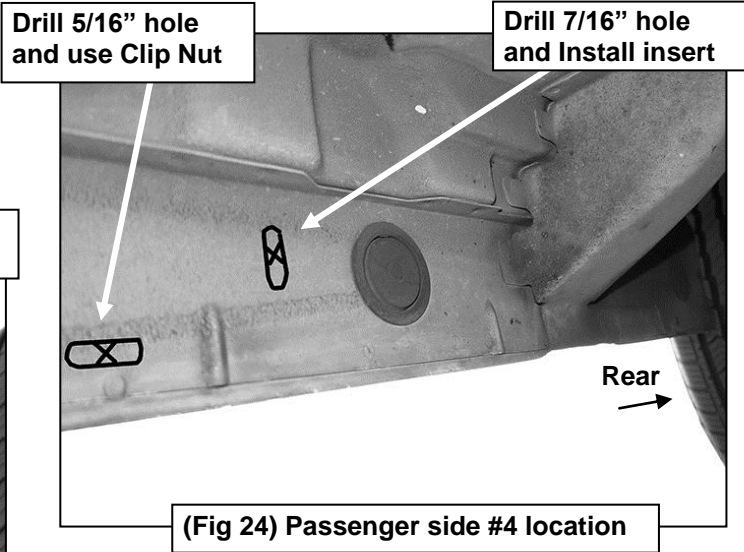
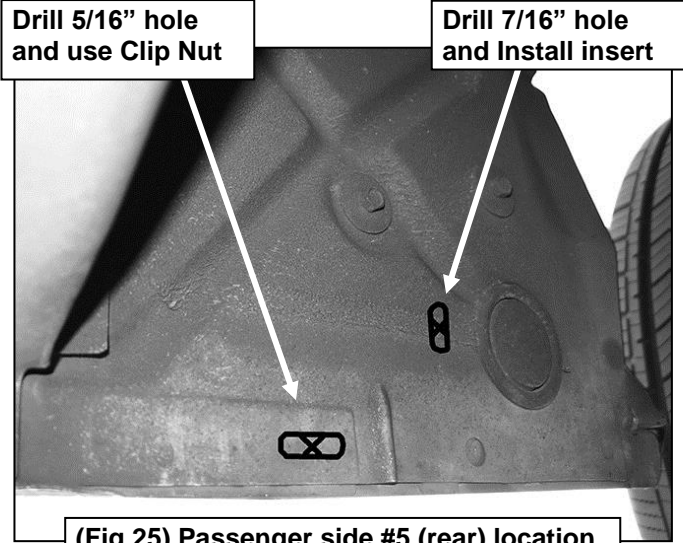

IMPORTANT: On some model/years, 8mm Threaded Inserts will need to be installed in locations indicated by arrows, (Fig 23-25). Level Running Board. Hold Bracket up in position against side of body panel. Mark location of slots onto sheet metal. Drill (3) 7/16" holes as required for passenger side #3, #4 and #5 (rear) Brackets only. Assemble Insert Tool and install Inserts as described in Steps 11a—i, (Fig 26-27).

