

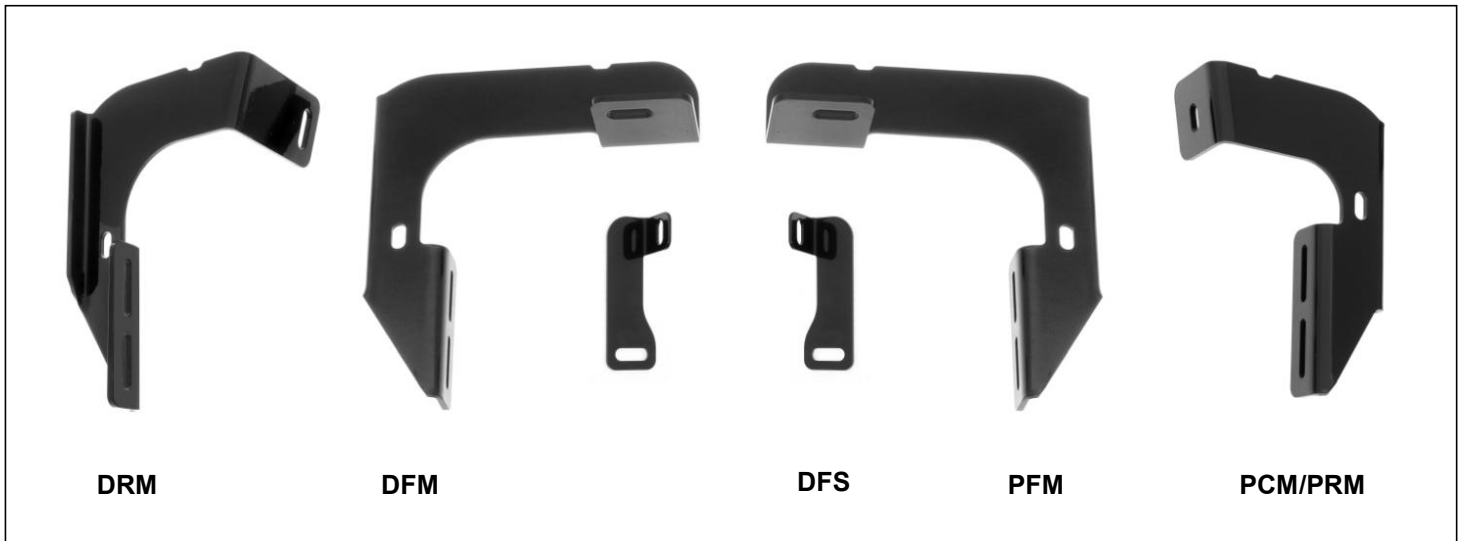

iRunning Board Installation Instruction

Application: For 2014-2018 RAM PROMASTER VAN 139" & 159" WHEELBASE (FULL SIZE)
PARTS LIST:

Item	Qty	Description	Item	Qty	Description
#1	1	Driver/left Running Board	#11	12	M8X1.25 - 25mm Hex Bolts
#2	1	Passenger/right Running Board	#12	6	M8 Large Flat Washers
#3	1	Driver/Left Side Front Bracket(DFM)	#13	24	M8 Small Flat Washers
#4	1	Driver/Left Side Rear Bracket(DRM)	#14	6	M8 Lock Washers
#5	1	Driver Side Front Support Bracket(DFS)	#15	6	M8 Hex Nuts
#6	1	Passenger Side Front Bracket(PFM)	#16	12	M8 Nylon Lock Nuts
#7	3	Passenger Side Center/Rear Brackets(PCM/PRM)	#17	12	M6 T-Bolts
#8	5	Passenger Side Support Brackets	#18	12	M6 Flat Washers
#9	6	M8X1.25 - 35mm Button Head Bolt Plates	#19	12	M6 Nylon Lock Nuts
#10	6	8mm Plastic Retainers			



PROCEDURE:

REMOVE CONTENTS FROM BOX. VERIFY ALL PARTS ARE PRESENT. READ INSTRUCTIONS CAREFULLY BEFORE STARTING INSTALLATION. DRILLING IS REQUIRED. ASSISTANCE IS RECOMMENDED.

1. Start the installation under the driver side of the vehicle. Locate the factory hole in the side of the inner body panel, **(Figures 1 & 3)**. **IMPORTANT:** Hole may be covered with rubber plug, sealing tape and/or heavy undercoating. Remove excess undercoating from all mounting locations so that Brackets will install flat against body panel and pinch weld.
2. Select (1) 8mm Bolt Plate and (1) 8mm Plastic Retainer, **(Figure 2)**. Thread the Retainer part way onto the Bolt Plate. Insert the Bolt Plate into the hole and tighten the Retainer against the body panel, **(Figure 3)**. **IMPORTANT:** The Plastic Retainer is designed to prevent the Bolt Plate from falling into the body panel and to aid in Bracket installation.
3. Select the driver/left front Mounting Bracket. Attach the Bracket to the Bolt Plate with (1) M8 Large Flat Washer, (1) M8 Lock Washer and (1) M8 Hex Nut, **(Figure 4)**. Leave hardware loose at this time
4. Select the unique driver/left front Support Bracket, **(Figure 5)**. Attach the Support Bracket to the front of the Mounting Bracket with (1) M8 x 25mm Hex Bolt, (2) M8 Small Flat Washers and (1) M8 Nylon Lock Nut, **(Figure 6)**. Line up the top of the Support Bracket with the outside of the pinch weld. Leave hardware loose at this time.

iRunning Board Installation Instruction

Application: For 2014-2018 RAM PROMASTER VAN 139" & 159" WHEELBASE (FULL SIZE)

5. Move to the driver side rear mounting location. Locate the factory hole in the bottom of the floor panel, **(Figure 7)**. Repeat **Steps 1—3** to attach the driver/left rear Bracket to the 8mm Bolt Plate, **(Figure 8)**.
6. Select (1) of the (5) identical Support Brackets, **(Figure 9)**. Attach the Support Bracket to the back of the rear Mounting Bracket with (1) M8 x 25mm Hex Bolt, (2) M8 Small Flat Washers and (1) M8 Nylon Lock Nut, **(Figure 10)**. Line up the top of the Support Bracket with the outside of the pinch weld. Leave hardware loose at this time.
7. Carefully unwrap the Running Boards. Place the short driver side Running Board on top of the (2) Brackets. Select (4) 6mm T-Bolts, **(Figure 11)**. Locate the channels in the bottom of the Running Board, **(Figure 12)**. Insert the T-Bolts into the channels closest to the Brackets. Lift the Running Board up and guide the studs down through the Brackets.
8. Attach the Running Board to the Brackets with (4) 6mm Flat Washers, (4) 6mm Nylon Lock Nuts, **(Figure 13)**. **NOTE:** The Running Board is designed to fit close to the vehicle. It may be necessary to loosen the Bracket hardware and tilt the Brackets downward to insert the Running Board between the Brackets and the body. Do not tighten hardware at this time.
9. Level and adjust the Running Board and tighten the Bracket to Bolt Plate hardware only. Remove the Running Board. Adjust the Support Brackets as necessary to move the top of the Brackets up to touch the bend in the pinch weld. Mark the location of the (2) slots in the Support Brackets onto the outside of the pinch weld, **(Figure 14)**.
10. Use a 5/16" drill bit to drill (2) holes through the pinch weld for the front and rear Support Brackets. **NOTE:** Drill the holes as far away from the bottom edge of the pinch weld as possible. **IMPORTANT:** Do not drill through the welds in the pinch weld if possible.

IMPORTANT! Any cutting or drilling tool may break or shatter. Government regulations require safety glasses & equipment at all times when cutting or drilling.

11. Attach the top of the Support Brackets to the outside of the pinch weld with (2) M8 x 25mm Hex Bolts, (4) M8 Small Flat Washers and (2) M8 Nylon Lock Nuts, **(Figure 15)**. Reinstall the Running Board. Level, adjust and tighten all hardware.
12. Move to the passenger side of the vehicle, **(Figure 16)**. Repeat **Steps 1—3** to attach the passenger side front Bracket, **(Figures 17 & 18)**. Repeat **Step 6** to attach (1) of the (5) identical Support Brackets.
13. Continue to the #2 mounting location, **(Figure 19)**. Repeat **Steps 5 & 6** to attach the #2 Mounting Bracket, **(Figure 20)**. Repeat to install the #3 and #4 (rear) Brackets, **(Figures 21—23)**.
14. Select the long passenger side running board. Select (8) 6mm T-Bolts, **(Figure 11)**. Locate the channels in the bottom of the Running Board, **(Figure 12)**. Insert the T-Bolts into the channels closest to the Brackets. Lift the Running Board up and guide the studs through the Brackets.
15. Attach the Running Board to the Brackets with (8) 6mm Flat Washers, (8) 6mm Nylon Lock Nuts, **(Figures 22 & 23)**.
16. Level and adjust the Running Board and tighten the Bracket to Bolt Plate hardware only. Remove the Running Board. Adjust the Support Brackets as necessary to move the top of the Brackets up to touch the bend in the pinch weld. Mark the location of the slots in the (3) Support Brackets onto the outside of the pinch weld, **(Figures 20 & 21)**.
17. Repeat **Steps 10 & 11** to drill and attach the (4) Support Brackets to the pinch weld.
18. Reinstall the Running Board. Level and adjust and tighten all hardware. **NOTE: Torque all M6 nylon lock nuts to 7 lb-ft.**
19. Do periodic inspections to the installation to make sure that all hardware is secure and tight.

To protect your investment, wax this product after installing. Regular waxing is recommended to add a protective layer over the finish. Do not use any type of polish or wax that may contain abrasives that could damage the finish.

For Polished Finishes: Aluminum polish may be used to polish small scratches and scuffs on the finish. Mild soap may be used also to clean the Running Board.

For black finishes: Mild soap may be used to clean the Running Board.

iRunning Board Installation Instruction

Application: For 2014-2018 RAM PROMASTER VAN 139" & 159" WHEELBASE (FULL SIZE)
Driver/left Side Installation Pictured

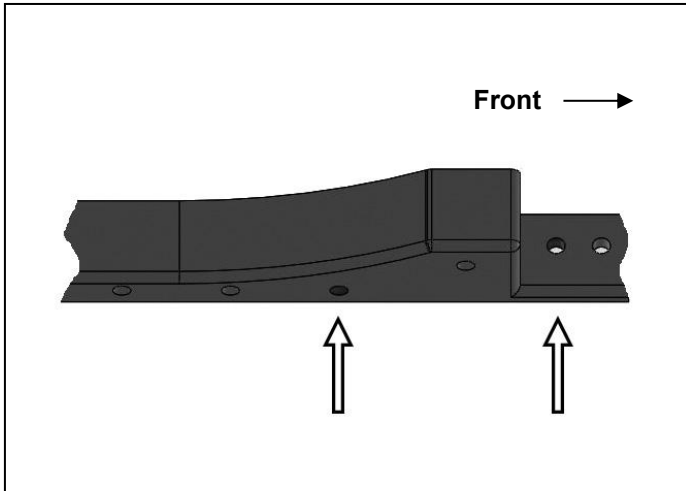

(Fig 1) Driver side front and rear mounting locations



(Fig 2) 8mm Bolt Plate with Plastic Retainer

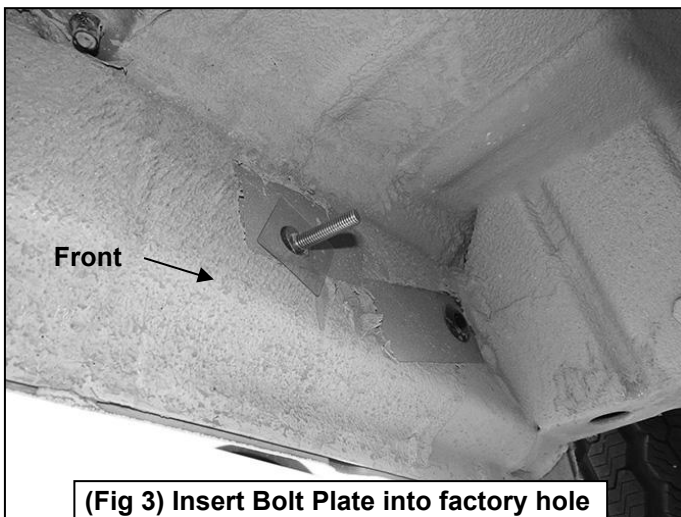

(Fig 3) Insert Bolt Plate into factory hole

8mm Large Flat Washer
8mm Lock Washer



(Fig 4) Driver side front Bracket pictured

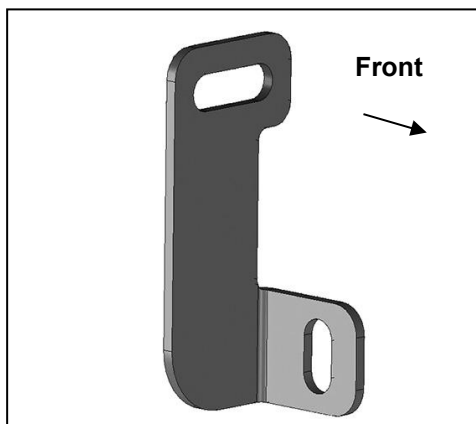

(Fig 5) Unique driver side front Support Bracket

iRunning Board Installation Instruction

Application: For 2014-2018 RAM PROMASTER VAN 139" & 159" WHEELBASE (FULL SIZE)
Driver/left Side Installation Pictured

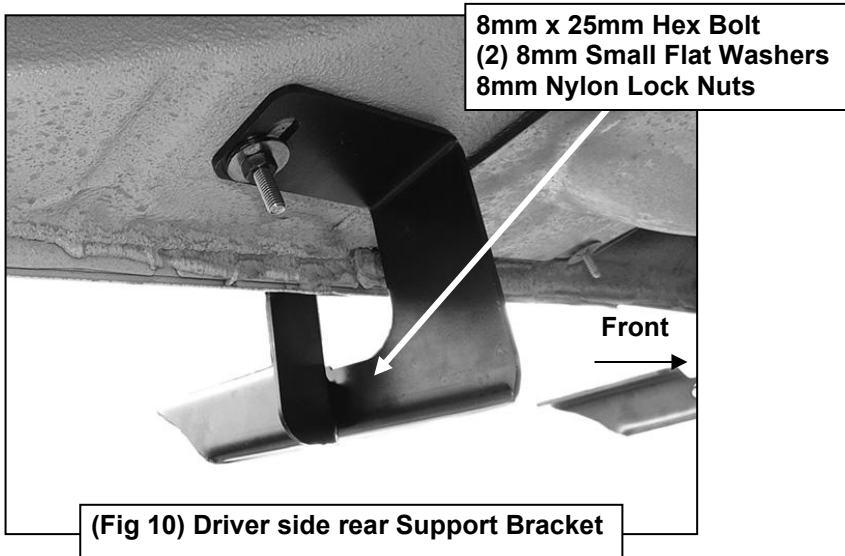
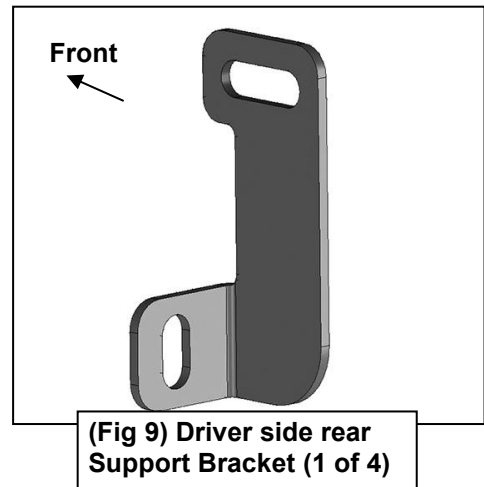
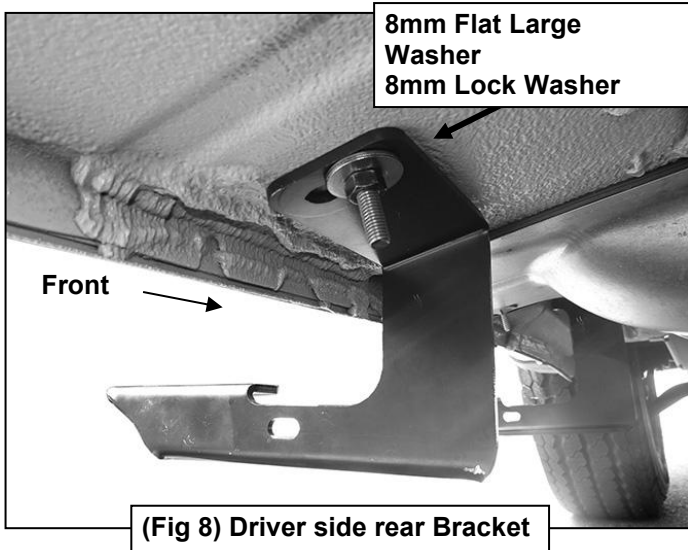
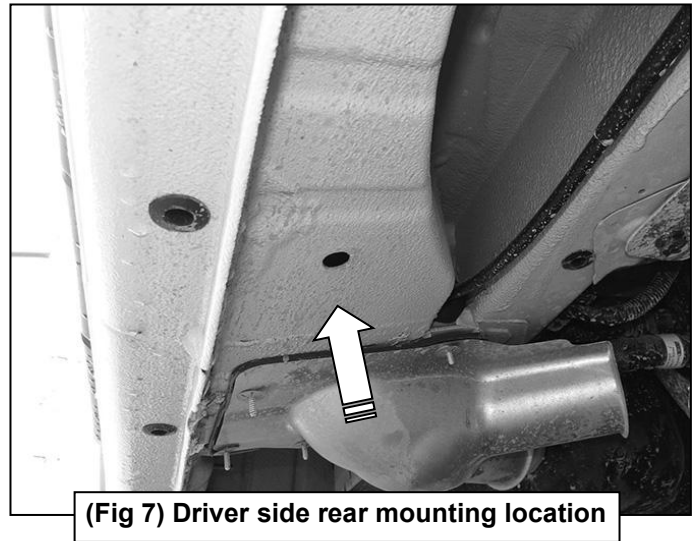
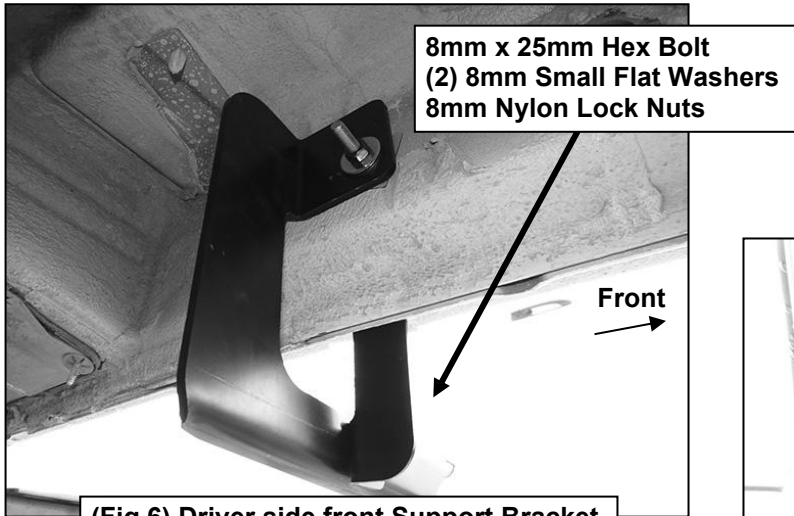

iRunning Board Installation Instruction

Application: For 2014-2018 RAM PROMASTER VAN 139" & 159" WHEELBASE (FULL SIZE)

Driver/left Side Installation Pictured

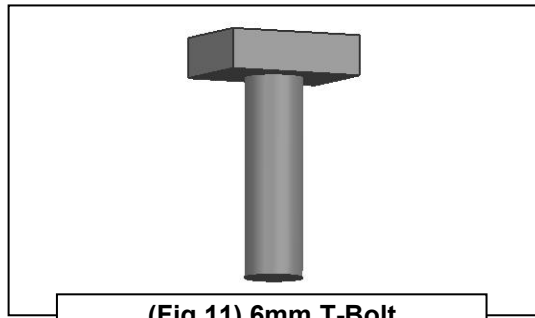

(Fig 11) 6mm T-Bolt

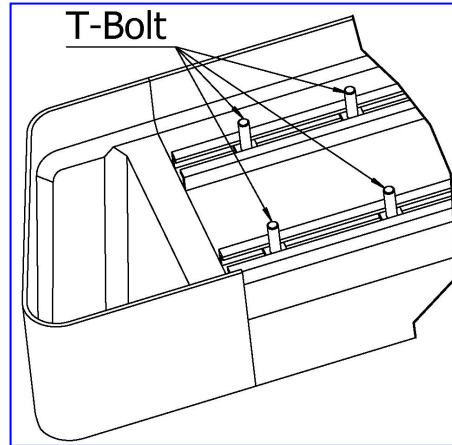

(Fig 12) Slip M6 T-bolts into the bottom channel

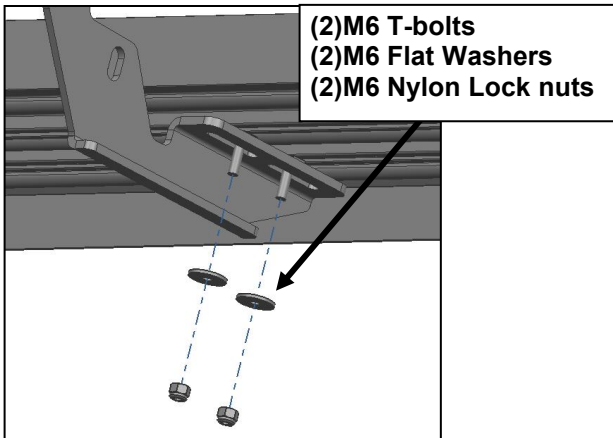

(Fig 13) Attach Running Board to Brackets



Level and adjust the Running Board. Temporarily remove the running board. Mark and drill 5/16" hole through pinch weld for each Support Bracket

Passenger/right Side Installation Pictured

iRunning Board Installation Instruction

Application: For 2014-2018 RAM PROMASTER VAN 139" & 159" WHEELBASE (FULL SIZE)

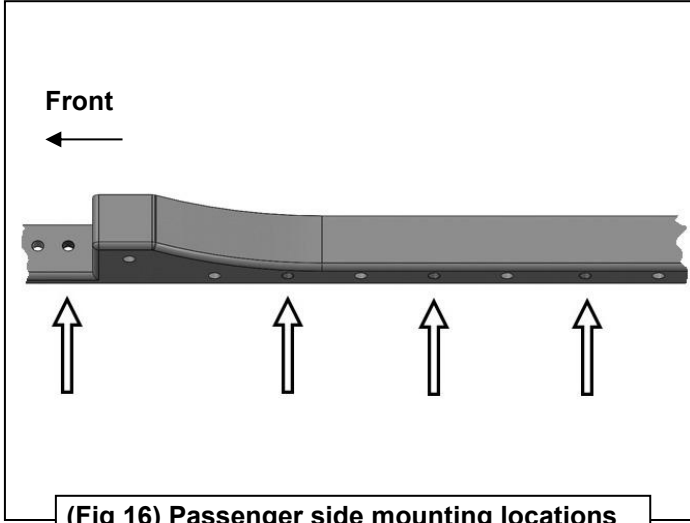

- (2) 8mm x 25mm Hex Bolts
- (2) 8mm Lock Washers
- (2) 8mm Flat Washers

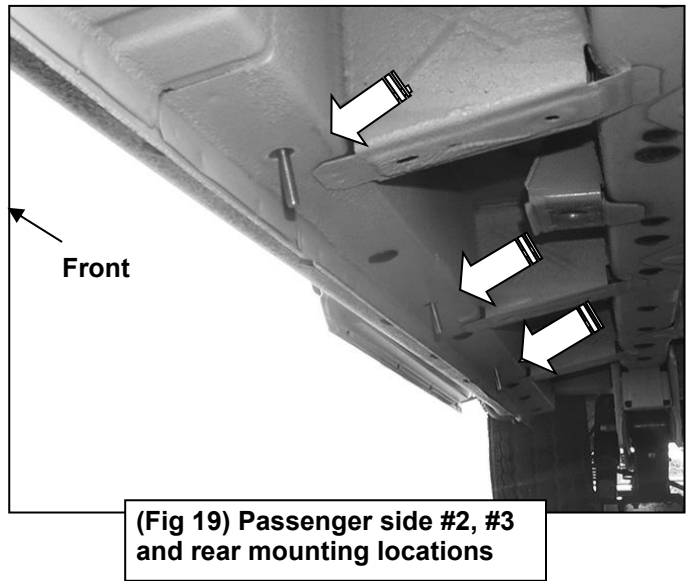
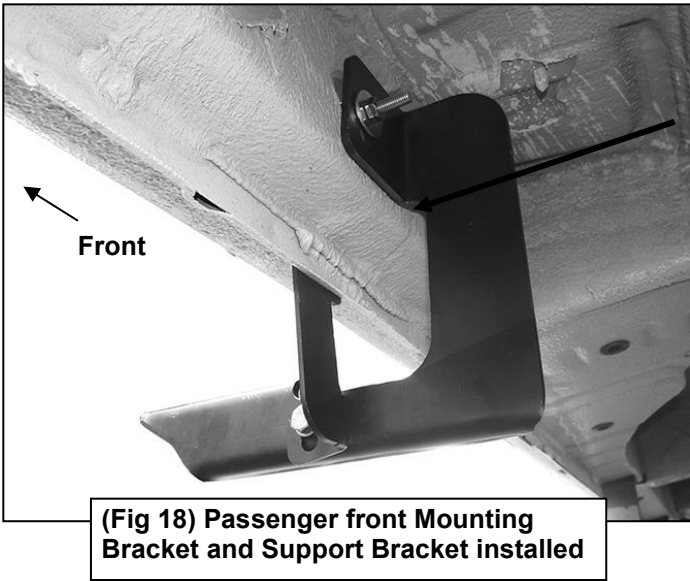
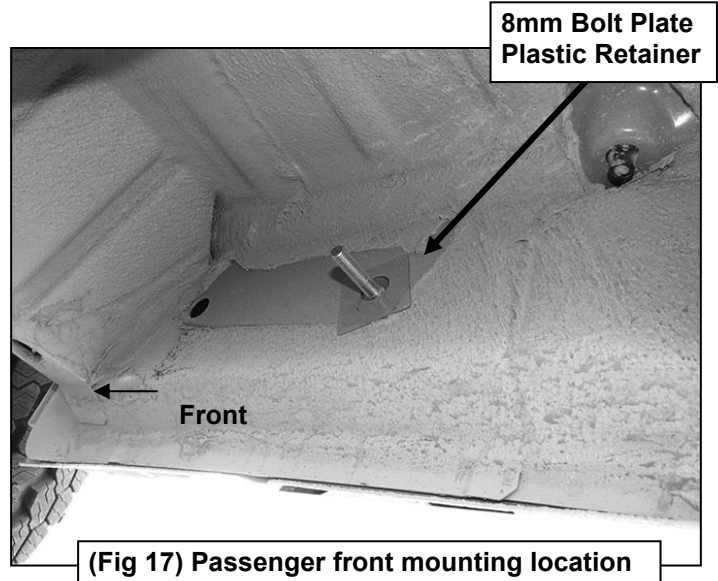

iRunning Board Installation Instruction

Application: For 2014-2018 RAM PROMASTER VAN 139" & 159" WHEELBASE (FULL SIZE)

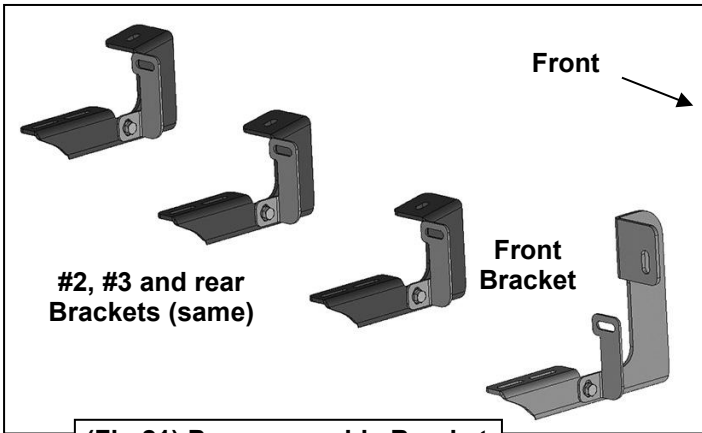

(Fig 21) Passenger side Bracket layout w-Support Brackets

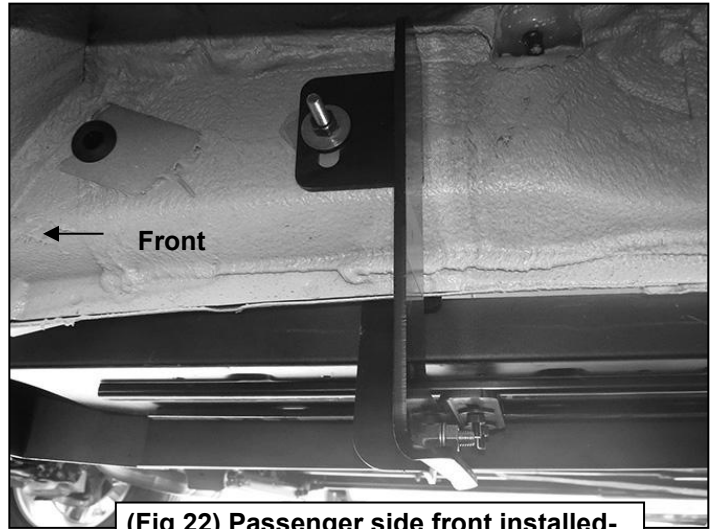

(Fig 22) Passenger side front installed-mark to drill through pinch weld

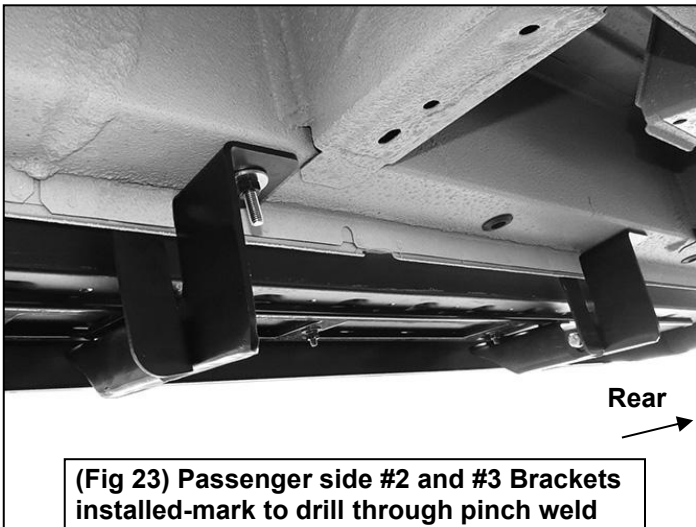

(Fig 23) Passenger side #2 and #3 Brackets installed-mark to drill through pinch weld