

PARTS LIST:

Item	QTY	Description	Item	QTY	Description
#1	2	Running Board(use for left or right)	#13	4	12-1.75mm x 120mm Hex Bolts
#2	1	Driver/Left Front Mounting Bracket (DF)	#14	4	12mm Flat Washers
#3	1	Driver/Left Front Support Bracket(long) (DFS)	#15	4	12mm Lock Washers
#4	1	Driver/Left Rear Mounting Bracket (DR)	#16	12	10-1.5mm x 30mm Hex Bolts
#5	1	Driver/Left Rear Support Bracket(short) (LRS)	#17	12	10mm Flat Washers
#6	1	Passenger/Right Front Mounting Bracket (RF)	#18	16	10mm Lock Washers
#7	1	Passenger/Right Front Support Bracket(long) (RFS)	#19	16	10mm Hex Nuts
#8	1	Passenger/Right Rear Mounting Bracket (RR)	#20	24	6-1.0mm x 20mm T-Bolts
#9	1	Passenger/Right Rear Support Bracket(short) (RRS)	#21	24	6mm x 22mm OD x 2mm Flat Washers
#10	4	14mm Spacer Washers	#22	24	6mm Lock Nuts
#11	4	10mm Plastic Retainers	#23	8	10mm Flat Washers (B)
#12	4	10mm x 35mm Bolt Plates			



PROCEDURE:

- 1. REMOVE CONTENTS FROM BOX. VERIFY ALL PARTS ARE PRESENT. READ INSTRUCTIONS CAREFULLY BEFORE STARTING INSTALLATION. ASSISTANCE IS RECOMMENDED.**
- Starting toward the front of the passenger side, remove the factory front body mount bolt with washer, **(Figure 1)**. Remove but do not discard the rubber bushing from the factory bolt.
- Select the passenger Front Mounting Bracket. Insert (1) 12mm x 120mm Hex Bolt with (1) 12mm Flat Washer and (1) 12mm Lock Washer through the Mounting Bracket. Place (1) Large Spacer Washer, **(Figure 2A)**, onto the Bolt then slide the rubber bushing onto the Hex Bolt against the Washer. Make sure that the Spacer Washer is between the Bracket and the factory rubber bushing, **(Figure 2B)**.
- Hold the Bracket and hardware up in place and attach to the factory body mount, **(Figure 3)**. Snug but do not tighten hardware at this time. **IMPORTANT:** On 2005 and newer model years,

the large washer on the factory body mount bolt may be removable, (do not discard-must reinstall), and the bolt is long enough to go through the Mounting Bracket and properly thread into the body mount. It is the installer's responsibility to check length and to determine whether to reuse the factory body bolt or the included replacement 12mm x 120mm Hex Bolt.

5. Remove the tape covering the factory hole in the back side of the lower body panel near the Mounting Bracket, **(Figures 1 & 3)**. Thread (1) Plastic Retainer part way onto (1) 10mm x 35mm Bolt Plate, **(Figure 4)**. Insert the Bolt Plate into the factory hole on the body panel, **(Figure 5A)**. Hold the Bolt Plate in place with one hand and continue to thread the Plastic Retainer down against the sheet metal to hold the Bolt Plate in place, **(Figure 5B)**.
IMPORTANT: The Plastic Retainer is designed to prevent the Bolt Plate from falling into the body panel and to aid in Bracket installation.
6. Select the passenger side front Support Bracket (long), **(Figure 6)**. Attach the Bracket to the Bolt Plate with (1) 10mm Flat Washer, (1) 10mm Lock Washer and (1) 10mm Hex Nut, **(Figure 7)**. **NOTE:** Place the lower flat end of the Support Bracket against the front facing side of the Mounting Bracket. The bent tab on the top of the Support Bracket should face the **front** of the vehicle. Do not tighten hardware at this time.
7. Attach the flat lower end of the front Support Bracket to the front of the Mounting Bracket with (1) 10mm x 30mm Hex Bolt, (2) 10mm Flat Washers, (1) 10mm Lock Washer and (1) 10mm Hex Nut, **(Figure 7)**. Do not tighten hardware at this time.
8. Move to the rear body mount at the back of the cab. Select the passenger side rear Mounting Bracket and (1) Spacer Washer. Repeat **Steps 2—4** for rear Mounting Bracket installation, **(Figure 8)**.
9. Remove the tape covering the hole in the inner rocker panel and install (1) Bolt Plate as described in **Step 5**. Select the passenger side rear Support Bracket(short) **(Figure 6)**. Attach the bent end of the top of the Bracket to the Bolt Plate with (1) 10mm Flat Washer, (1) 10mm Lock Washer and (1) 10mm Hex Nut, **(Figure 9)**. **NOTE:** Place Support Bracket against the front facing side of the Mounting Bracket. The bent tab on the top of the rear Support Bracket should face the **rear** of the vehicle.
10. Repeat **Step 7** to attach the flat lower end of the Support Bracket to the front of the rear Mounting Bracket, **(Figure 10)**. Snug but do not tighten hardware at this time.
11. Select the Running Board. Slip (8) 6mm T-Bolts into each bottom channel **(Figure 11)**. Carefully position the Running Board onto the (2) Mounting Brackets. **IMPORTANT:** Do not slide the Running Board on the Brackets or damage to the finish may result. Attach the Running Board to the Mounting Brackets with (4) 6mm T-bolts,(4)6mm flat washers and (4)6mm lock nuts **(Figure 12)**. Do not tighten hardware.
12. Properly level and adjust the Running Board and tighten all hardware at this time.
13. Repeat **Steps 2—14** for the driver/left Running Board installation. **IMPORTANT:** Driver Front Lower Bracket and Passenger Rear Lower Bracket are identical. Driver Rear Lower Bracket and Passenger front Lower Bracket are identical.
14. Do periodic inspections to the installation to make sure that all hardware is secure and tight.

To protect your investment, wax this product after installing. Regular waxing is recommended to add a protective layer over the finish. Do not use any type of polish or wax that may contain abrasives that could damage the finish.

For Polished Finishes: Aluminum polish may be used to polish small scratches and scuffs on the finish. Mild soap may be used also to clean the Running Board.

For black finishes: Mild soap may be used to clean the Running Board.

Passenger Side Installation Pictured

Remove body mount
bolt and washer

Remove sealing tape to
uncover mounting hole

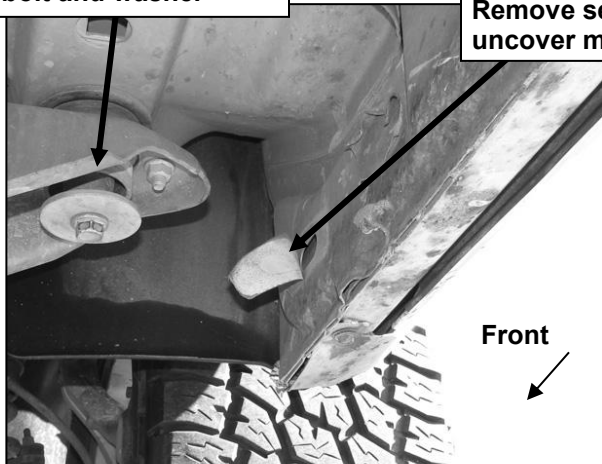

(Fig 1) Passenger side front body mount



(Fig 2A) Spacer Washer

IMPORTANT: Insert (1) Spacer Washer
between each front and rear Mounting Bracket
and factory rubber bushing (passenger side
front Mounting Bracket pictured)



(Fig 2B) Passenger/rear
Bracket for example only



(Fig 3) Passenger/front Upper Bracket installation

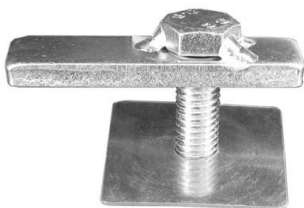

(Fig 4) Bolt Plate w/Retainer

Insert Bolt Plate into oval hole.
Thread Plastic Retainer down
flush against sheetmetal

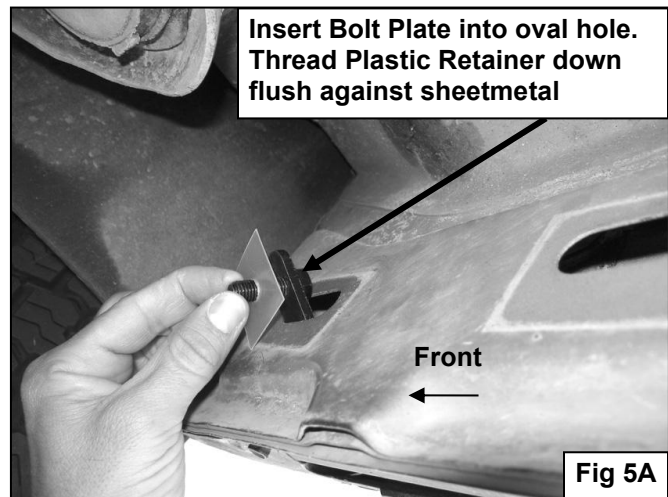

Fig 5A

Passenger Side Installation Pictured



Fig 5B

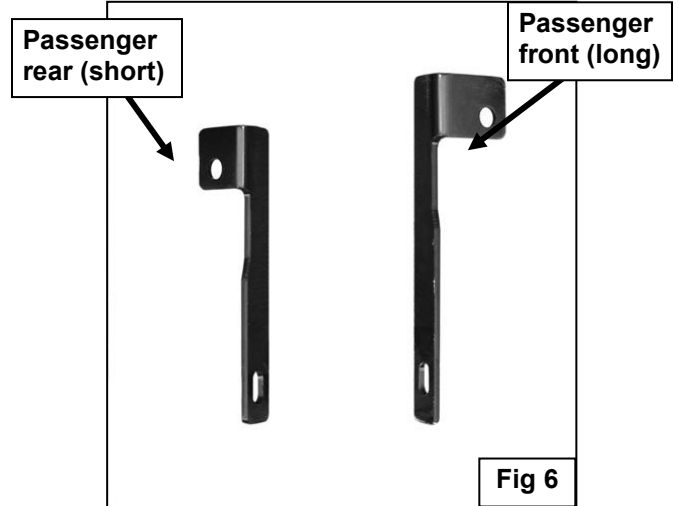

Fig 6

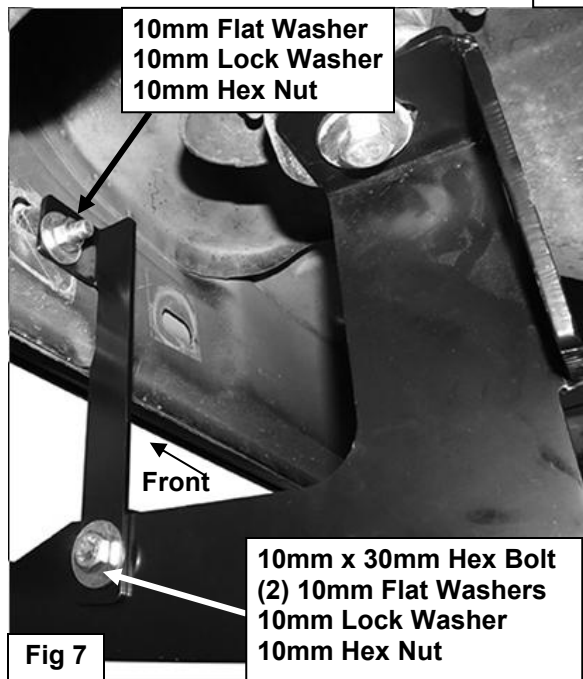
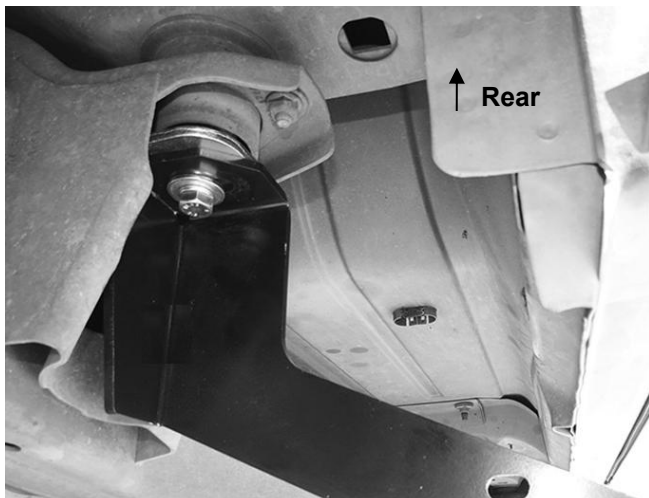

Fig 7



(Fig 8) Passenger side rear body mount

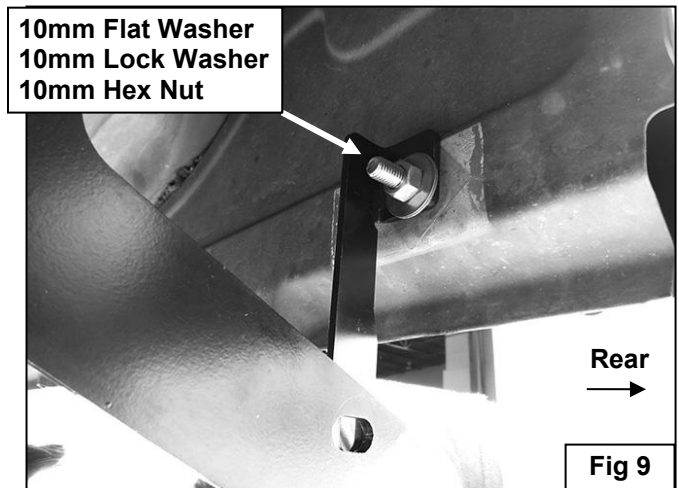
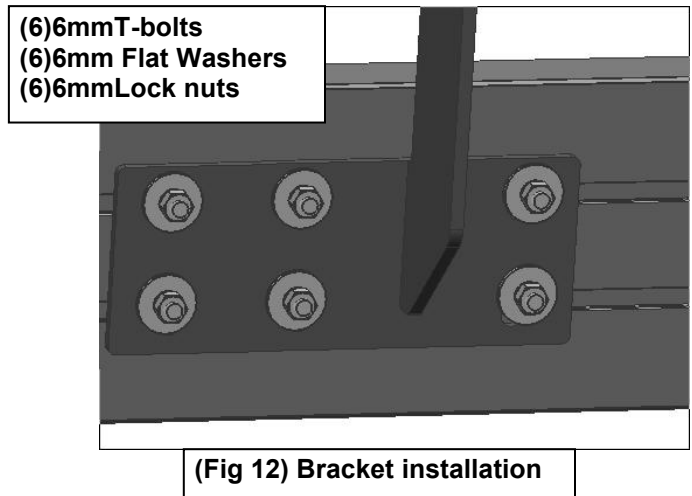
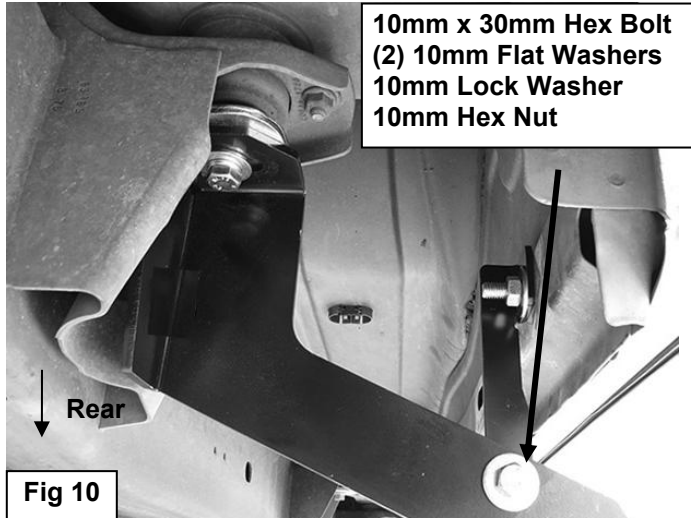

Fig 9

Passenger Side Installation Pictured



Complete Installation