

PARTS LIST:

Item	Qty	Description	Item	Qty	Description
#1	1	Driver/left Running Board	#10	6	10mm Lock Washers
#2	1	Passenger/right Running Board	#11	6	10-1.5mm Hex Nuts
#3	2	Driver/left Side Mounting Brackets	#12	24	8-1.25mm x 30mm Hex Bolts
#4	1	Passenger/right Front Mounting Bracket	#13	48	8mm x 24mm x 2mm Flat Washers
#5	3	Passenger 2nd, 3rd and Rear Brackets	#14	24	8mm Lock Washers
#6	6	Support Brackets	#15	24	8mm Hex Nuts
#7	6	10-1.5mm x 30mm Bolt Plates	#16	12	6-1.0mm x 20mm T-Bolts
#8	6	10mm Plastic Retainers	#17	12	6mm x 18mm OD x 1.6mm Flat Washers
#9	6	10mm x 24mm x 2.2mm Flat Washers	#18	12	6mm Hex Nuts

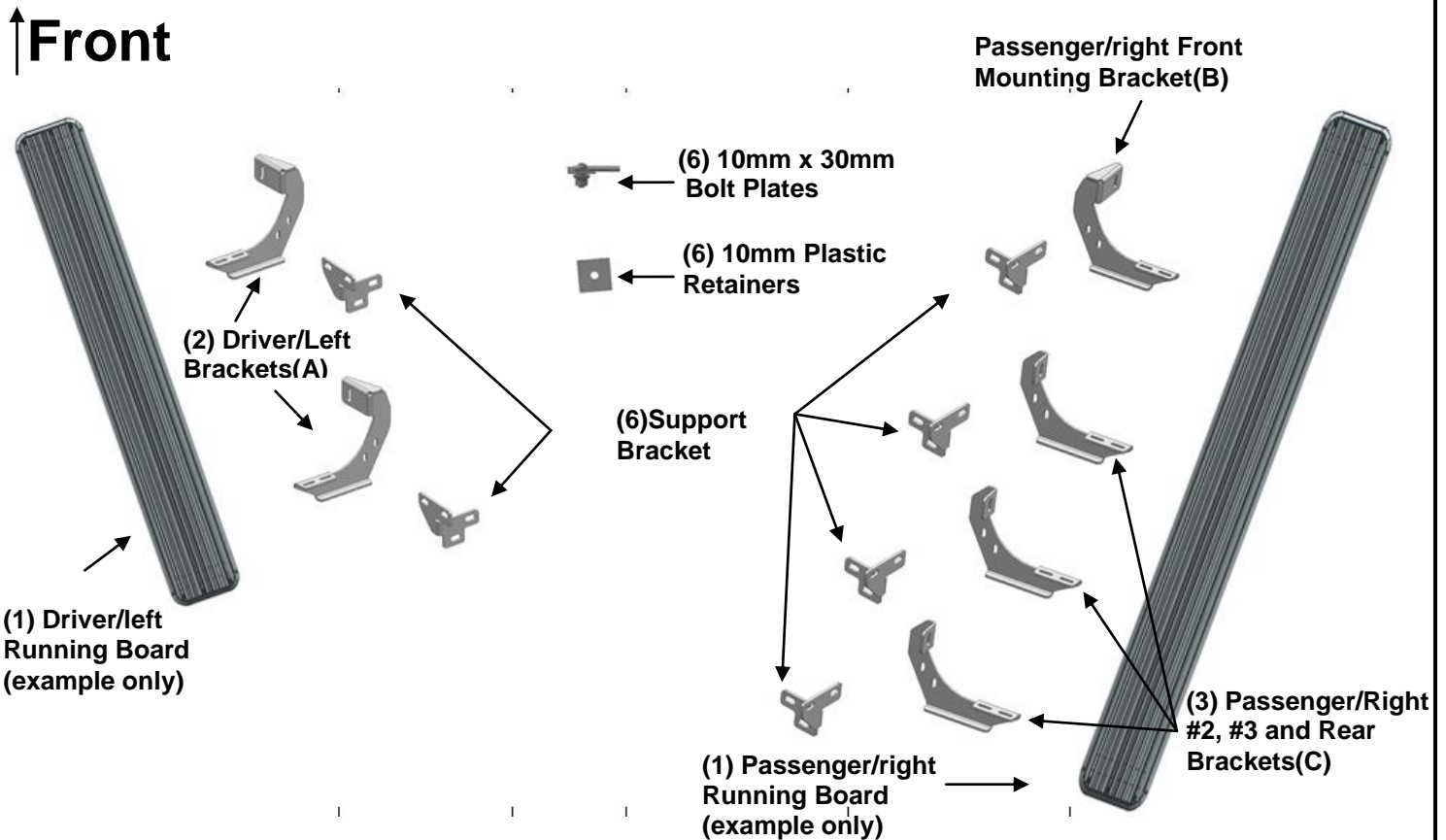

PROCEDURE:

REMOVE CONTENTS FROM BOX. VERIFY ALL PARTS ARE PRESENT. READ INSTRUCTIONS CAREFULLY BEFORE STARTING INSTALLATION.

- Starting on the passenger/right side of the vehicle, locate the factory hole in the inner body panel closest to the front tire opening, **(Figures 1 & 2)**. Remove the rubber plug. **NOTE:** Mounting locations may be covered with heavy undercoating. Refer to instructions to find all mounting locations.
- Select (1) 10mm Bolt Plate and (1) 10mm Plastic Retainer. Partially thread the Retainer onto the Bolt Plate, **(Figure 3)**. Insert Bolt Plate into the hole in the inner body panel, **(Figure 4)**. Once the Bolt Plate is inserted, hold the Bolt end with one hand and tighten the Plastic Retainer with your other hand until it

is tight against the body panel. **IMPORTANT:** The Plastic Retainer is designed to prevent the Bolt Plate from falling into the body panel and to aid in Bracket installation.

3. Select the unique Passenger/right Front Bracket, **(Figure 5)**. Attach the Bracket to the Bolt Plate with (1) 10mm Flat Washer, (1) 10mm Lock Washer and (1) 10mm Hex Nut. Do not tighten hardware at this time. **IMPORTANT:** The Mounting Brackets look similar. Use the illustration above and the instructions to properly identify and separate the Brackets for proper installation.
4. Next, select (1) Support Bracket. Attach the Support Bracket to the back of the front Mounting Bracket with (2) 8mm x 30mm Hex Bolts, (4) 8mm Flat Washers, (2) 8mm Lock washers and (2) 8mm Hex Nuts, **(Figure 6)**. Line up the mounting flange on the Support Bracket with the outside of the pinch weld, **(Figure 12)**.
5. Repeat **Steps 1—4** to install the passenger side 2nd, 3rd and rear Mounting Brackets and Support Brackets, **(Figures 7—11)**.
6. Select the long passenger side Running Board. Place the Running Board on top of the (4) Brackets. Level and adjust the Running Board and fully tighten the Bracket to vehicle hardware only. Temporarily remove the Running Board.
7. Make sure the Brackets are level to the vehicle. Line up the slots on each Support Bracket with the outside of the pinch weld. Mark the location of the slots onto the pinch weld, **(Figure 12)**. **IMPORTANT:** Do not drill too close to the bottom edge of the pinch weld. Adjust Support Brackets and/or Mounting Brackets so that slots in Support Brackets are not too close to the bottom edge of the pinch weld. Once the Running Board and Brackets are properly adjusted and slot locations marked, remove the Running Board and Support Brackets. Use a 5/16" drill bit to drill the (2) holes through the pinch weld for each Support Bracket, **(Figure 13)**.
8. Attach each Support Bracket to the outside of the pinch weld with (2) 8mm Hex Bolts, (4) 8mm Flat Washers, (2) 8mm Lock Washers and (1) 8mm Hex Nuts, **(Figures 13, 14 & 18)**. Repeat this Step to attach all Support Brackets. Tighten the hardware attaching the Support Brackets to the vehicle only.
9. Place the long driver side Running Board on top of the **(4)** Brackets. Slip **(8)** 6mm T-bolts into each bottom channel **(Figure 19)**. Carefully position the Running Board onto the **(4)** Mounting Brackets. **IMPORTANT:** Do not slide, (front to back), the Running Board on the Brackets or damage to the finish may result. Attach the Running Board to the Mounting Brackets with **(2)** 6mm T-bolts, **(2)** 6mm flat washers and **(2)** 6mm lock nuts **(Figures 20)**. Do not tighten at this time.
10. Move to the driver side of the vehicle. Repeat **Steps 1—4** to install the driver side front Mounting Bracket and Support Bracket, **(Figures 15—17)**. **NOTE:** The (2) Driver side Brackets are identical.
11. Next, locate and remove the 3rd rubber plug along the body panel. Repeat this **Steps** to install the driver side rear Bracket and Support Bracket, **(Figure 18)**.
12. Place the short driver side Running Board on top of the (2) Brackets. Slip (4) 6mm T-bolts into each bottom channel **(Figure 19)**. Carefully position the Running Board onto the (2) Mounting Brackets. **IMPORTANT:** Do not slide, (front to back), the Running Board on the Brackets or damage to the finish may result. Attach the Running Board to the Mounting Brackets with (2) 6mm T-bolts, (2) 6mm flat washers and (2) 6mm lock nuts **(Figures 20)**. Do not tighten at this time. Level and adjust the Running Board properly and tighten all hardware.
13. Select the driver/left Running Board. Repeat **Steps 5—8** to drill the pinch weld to install the Support Brackets and Running Board.
14. Level and adjust the Running Board properly and tighten all hardware.
15. Do periodic inspections to the installation to make sure that all hardware is secure and tight.

To protect your investment, wax this product after installing. Regular waxing is recommended to add a protective layer over the finish. Do not use any type of polish or wax that may contain abrasives that could damage the finish.

For Polished Finishes: Aluminum polish may be used to polish small scratches and scuffs on the finish. Mild soap may be used also to clean the Running Board.

For black finishes: Mild soap may be used to clean the Running Board.

Passenger Side Installation Pictured

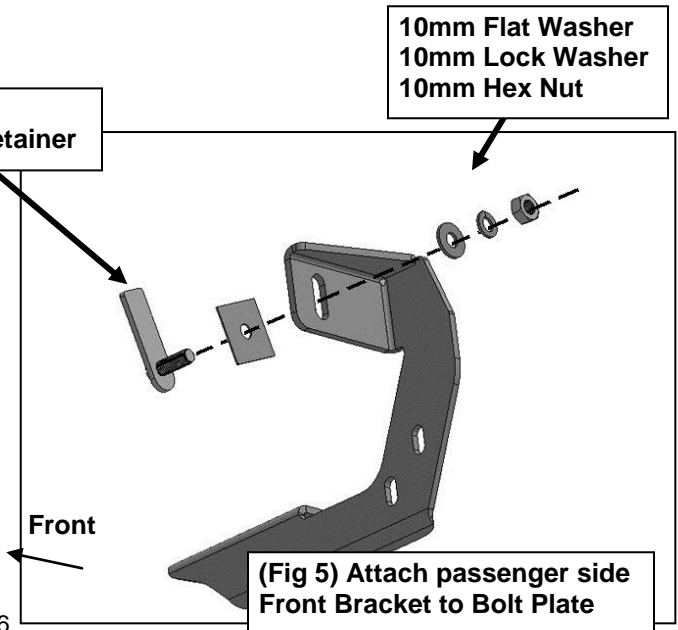
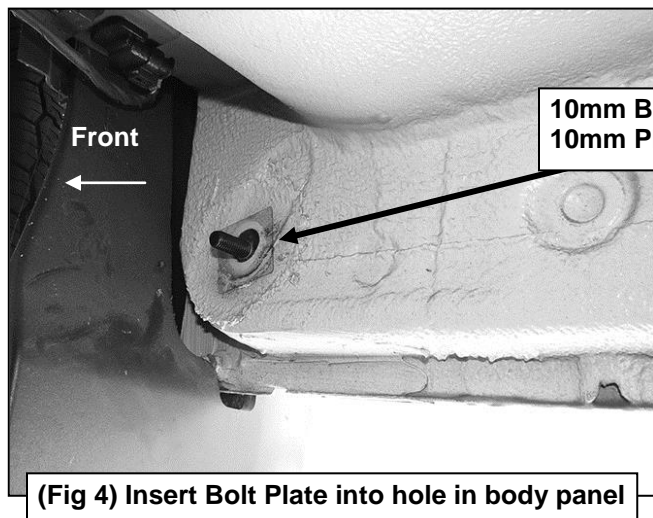
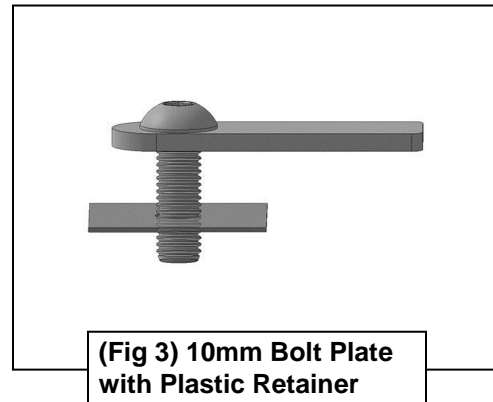
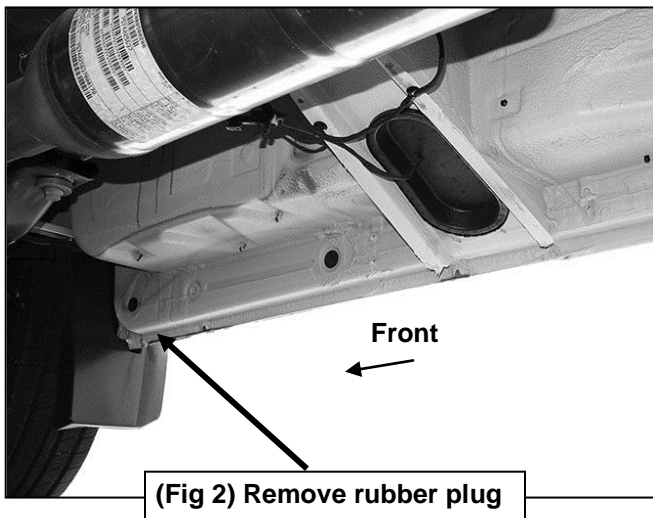
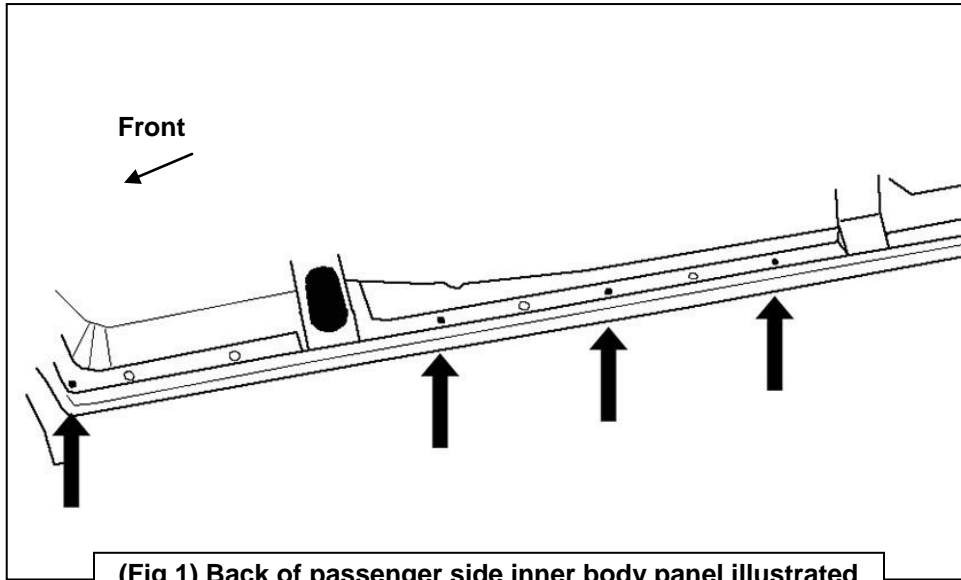

Passenger Side Installation Pictured

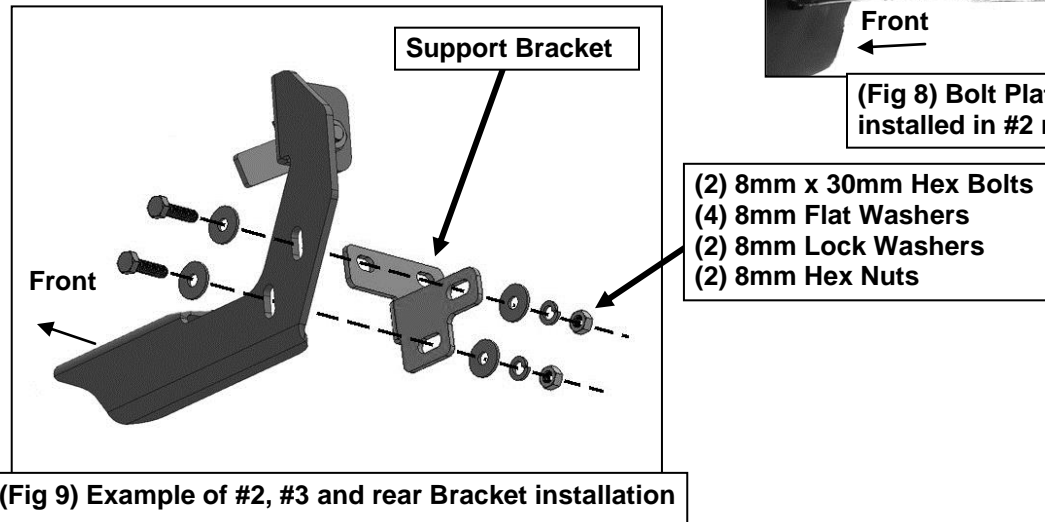
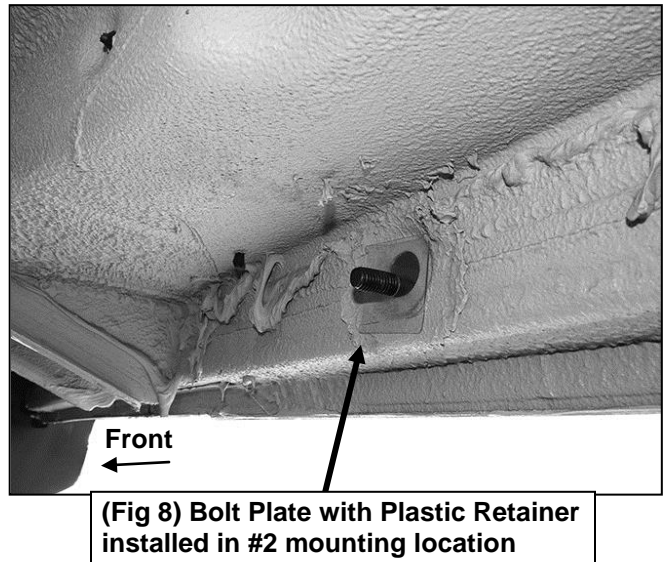
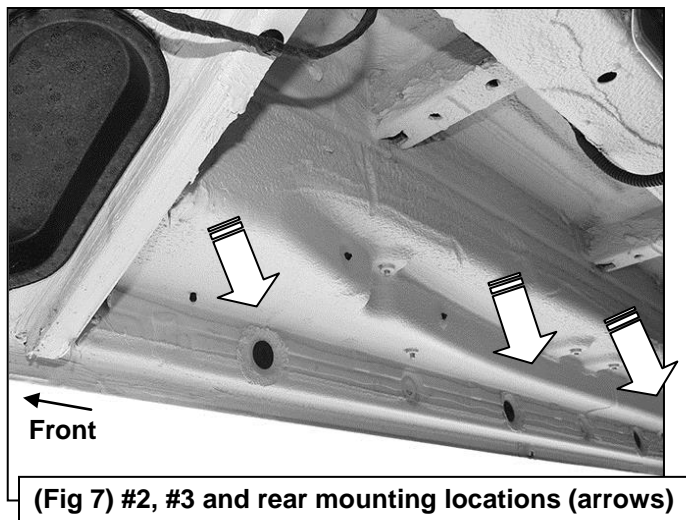
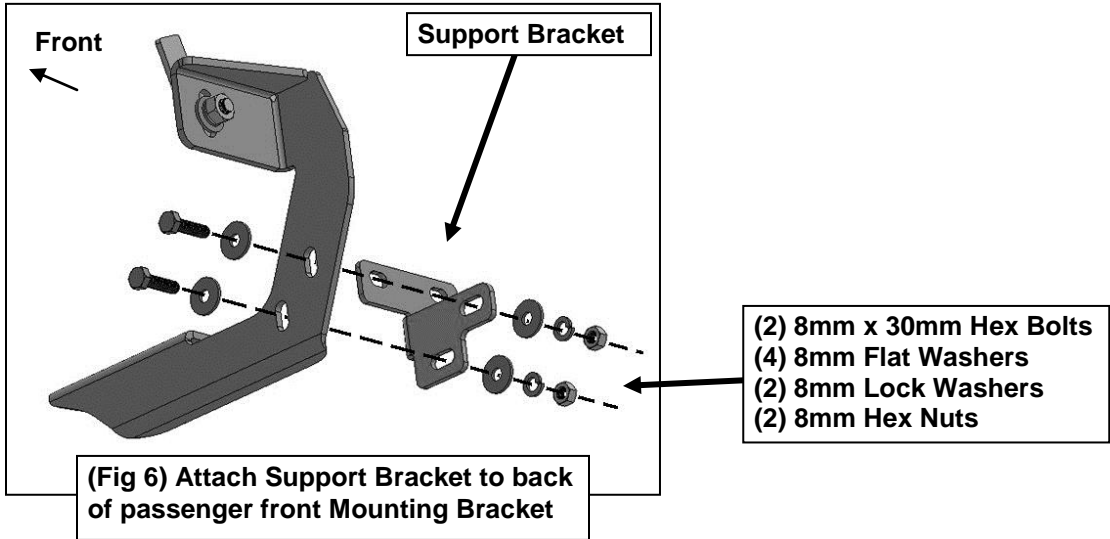

Passenger Side Installation Pictured

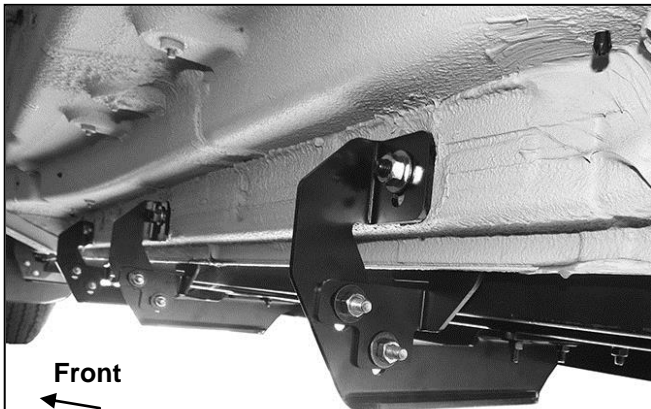

(Fig 11) Passenger side #2, #3 and rear Brackets

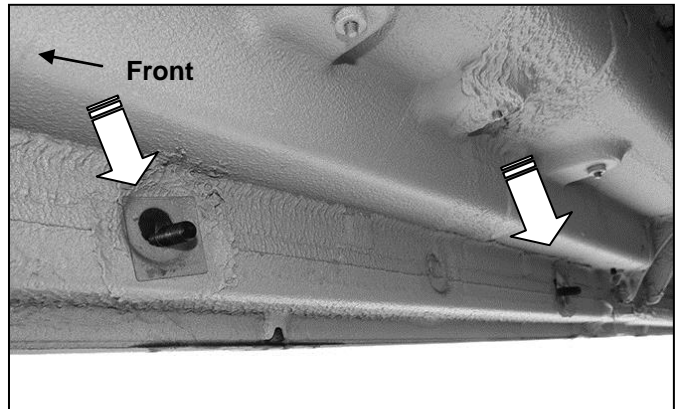

(Fig 10) Bolt Plates with Plastic Retainers installed in #3 and rear mounting locations (arrows)

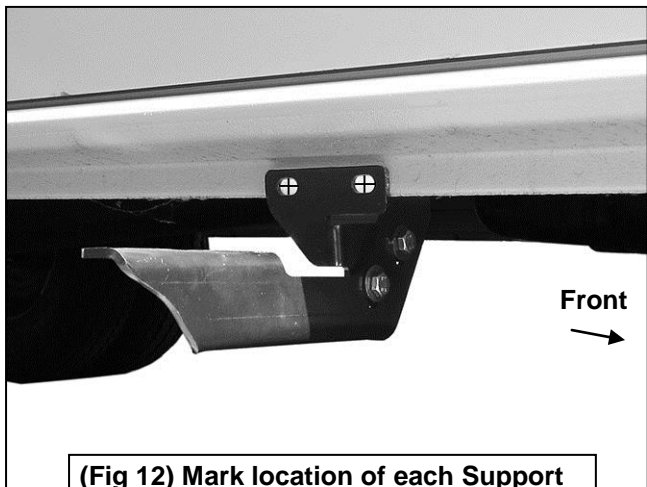

(Fig 12) Mark location of each Support Bracket onto pinch weld before drilling

- (2) 8mm x 30mm Hex Bolts
- (4) 8mm Flat Washers
- (2) 8mm Lock Washers
- (2) 8mm Hex Nuts

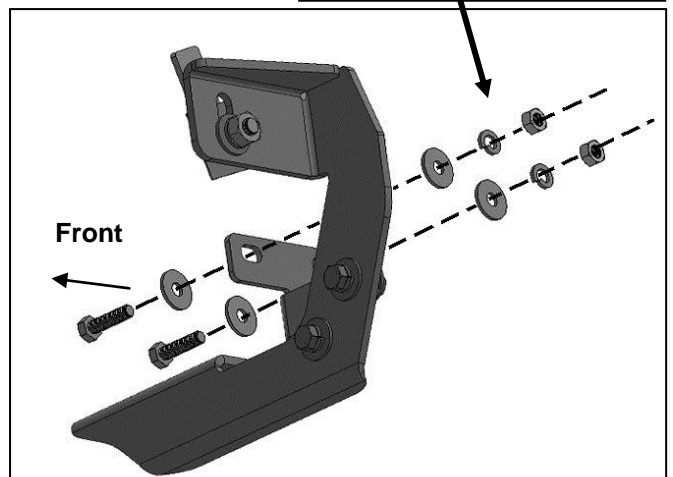

(Fig 13) Attach Support Bracket to pinch weld (passenger front Bracket illustrated)

- (2) 8mm x 30mm Hex Bolts
- (4) 8mm Flat Washers
- (2) 8mm Lock Washers
- (2) 8mm Hex Nuts

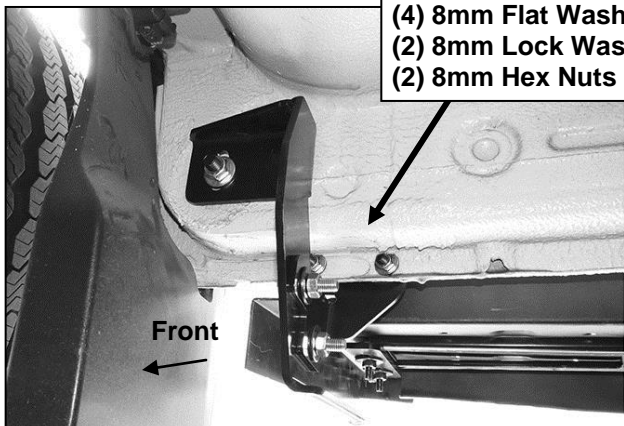

(Fig 14) Passenger side complete installation

IB(6",5",4")RUNNING BOARD
 07-09 DODGE SPRINTER (FULL SIZE), 07-09 FREIGHTLINER SPRINTER (FULL SIZE),
 10-17 MERCEDES-BENZ SPRINTER (FULL SIZE)
 (Excl. Passenger Van With Rear Air)

Driver Side Installation Pictured

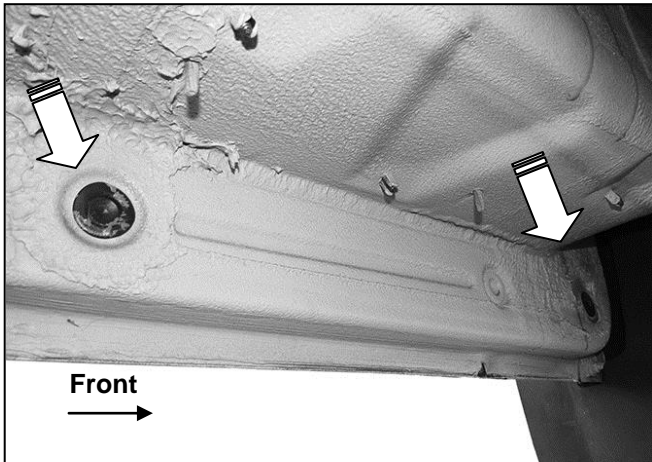

(Fig 15) Driver/left side mounting locations (arrows)

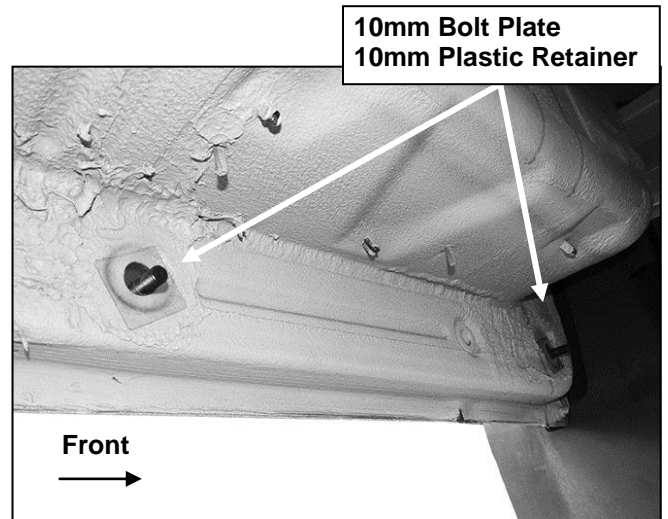

(Fig 16) Bolt Plates with Plastic Retainers installed in driver side front and rear mounting locations

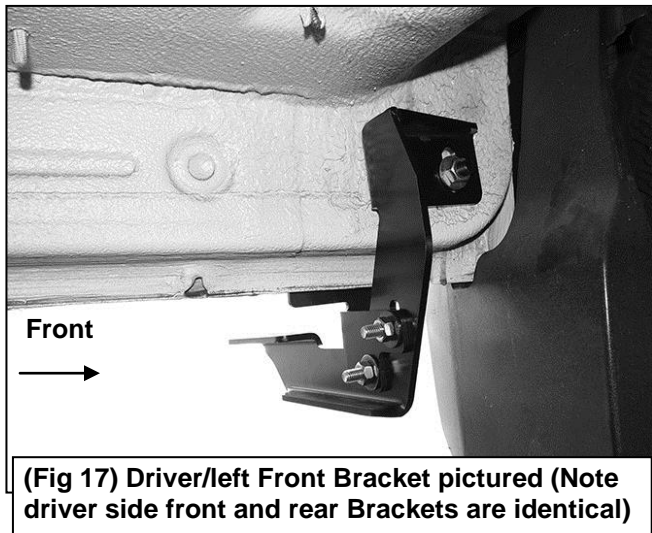

(Fig 17) Driver/left Front Bracket pictured (Note driver side front and rear Brackets are identical)

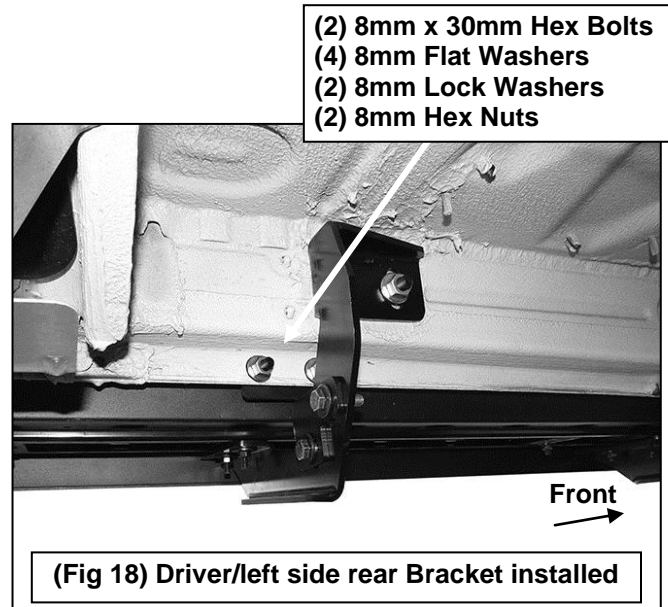

(Fig 18) Driver/left side rear Bracket installed



(Fig 19) Slip 6mm T-bolts into the bottom channel

- (2)6mm T-bolts
- (2)6mm Flat Washers
- (2)6mm Hex Nuts

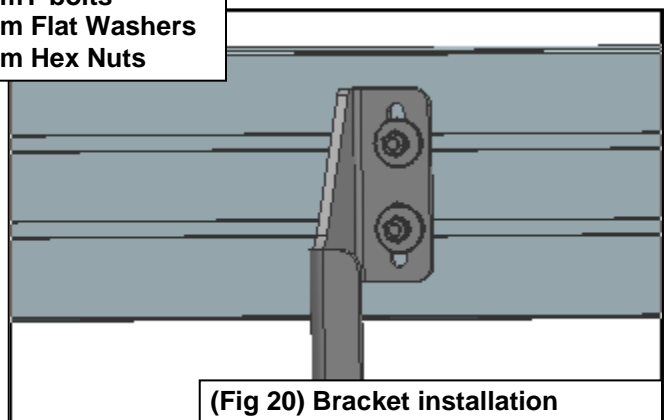

(Fig 20) Bracket installation