

PARTS LIST:

Item	Qty	Description	Item	Qty	Description
#1	1	Driver/left Running Board	#11	12	8-1.25mm x 25mm Hex Bolts
#2	1	Passenger/right Running Board	#12	6	8mm x 28mm OD x 3mm Large Flat Washers
#3	1	Driver/Left Side Front Bracket	#13	24	8mm x 16mm OD x 1.6mm Small Flat Washers
#4	1	Driver/Left Side Rear Bracket	#14	6	8mm Lock Washers
#5	1	Driver/Left Side Front Support Bracket	#15	6	8mm Hex Nuts
#6	1	Passenger/Right Side Front Bracket	#16	12	8mm Nylon Lock Nuts
#7	3	Passenger/Right Side Center/Rear Brackets	#17	12	6-1.0mm x 20mm T-Bolts
#8	5	Passenger/Right Side Support Brackets (1-driv rear)	#18	12	6mm x 18mm OD x 1.6mm Flat Washers
#9	6	8-1.25mm x 35mm Button Head Bolt Plates	#19	12	6mm Hex Nuts
#10	6	8mm Plastic Retainers			

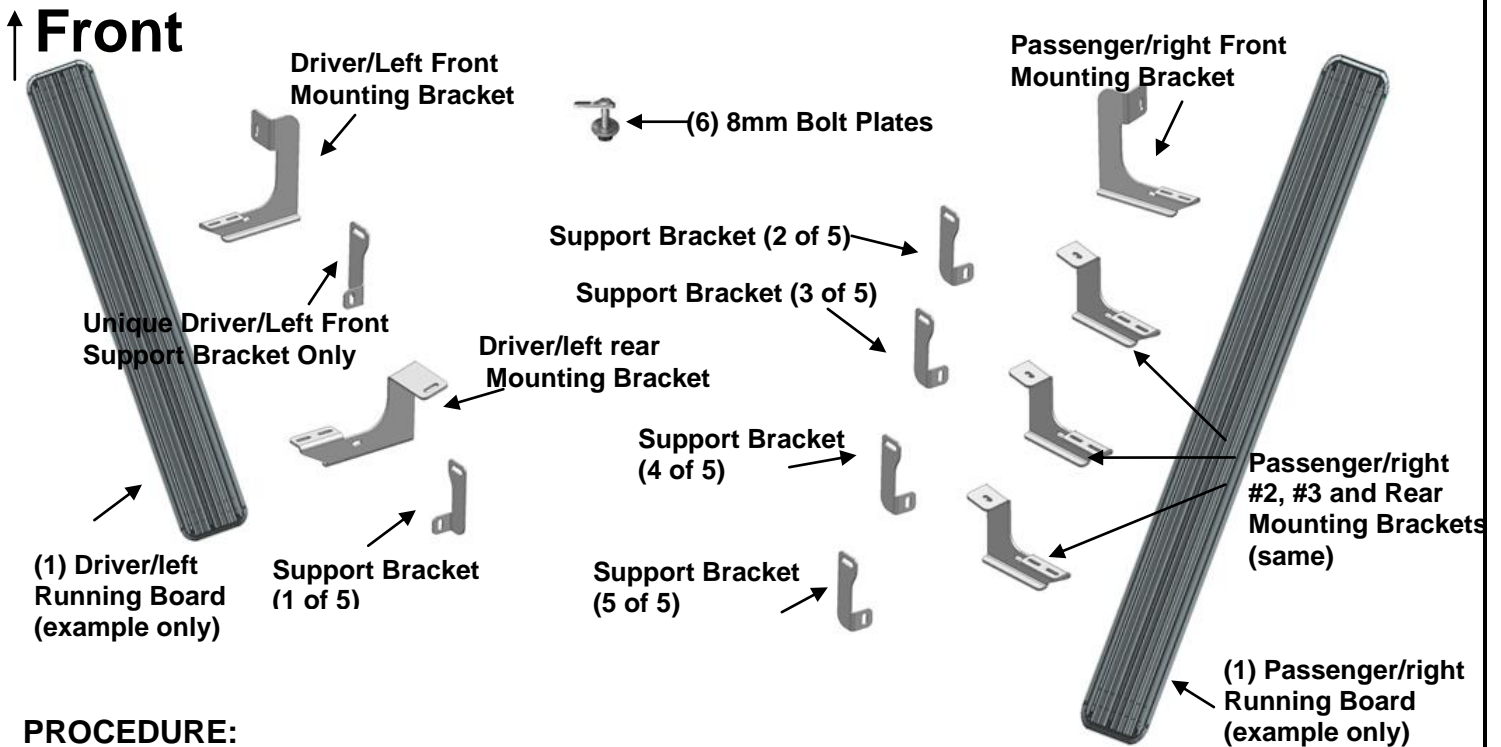

PROCEDURE:

REMOVE CONTENTS FROM BOX. VERIFY ALL PARTS ARE PRESENT. READ INSTRUCTIONS CAREFULLY BEFORE STARTING INSTALLATION.

1. Start the installation under the driver side of the vehicle. Locate the factory hole in the side of the inner body panel, (**Figures 1 & 3**). **IMPORTANT:** Hole may be covered with rubber plug, sealing tape and/or heavy undercoating. Remove excess undercoating from all mounting locations so that Brackets will install flat against body panel and pinch weld.
2. Select (1) 8mm Bolt Plate and (1) 8mm Plastic Retainer, (**Figure 2**). Thread the Retainer part way onto the Bolt Plate. Insert the Bolt Plate into the hole and tighten the Retainer against the body panel, (**Figure 3**). **IMPORTANT:** The Plastic Retainer is designed to prevent the Bolt Plate from falling into the body panel and to aid in Bracket installation.
3. Select the driver/left front Mounting Bracket. Attach the Bracket to the Bolt Plate with (1) 8mm x 28mm Large Flat Washer, (1) 8mm Lock Washer and (1) 8mm Hex Nut, (**Figure 4**). Leave hardware loose at this time

4. Select the unique driver/left front Support Bracket, **(Figure 5)**. Attach the Support Bracket to the front of the Mounting Bracket with (1) 8mm x 25mm Hex Bolt, (2) 8mm x 16mm Small Flat Washers and (1) 8mm Nylon Lock Nut, **(Figure 6)**. Line up the top of the Support Bracket with the outside of the pinch weld. Leave hardware loose at this time.
5. Move to the driver side rear mounting location. Locate the factory hole in the bottom of the floor panel, **(Figure 7)**. Repeat **Steps 1—3** to attach the driver/left rear Bracket to the 8mm Bolt Plate, **(Figure 8)**.
6. Select (1) of the (5) identical Support Brackets, **(Figure 9)**. Attach the Support Bracket to the back of the rear Mounting Bracket with (1) 8mm x 25mm Hex Bolt, (2) 8mm x 16mm Small Flat Washers and (1) 8mm Nylon Lock Nut, **(Figure 10)**. Line up the top of the Support Bracket with the outside of the pinch weld. Leave hardware loose at this time.
7. Adjust the Support Brackets as necessary to move the top of the Brackets up to touch the bend in the pinch weld. Mark the location of the (2) slots in the Support Brackets onto the outside of the pinch weld, **(Figure 11)**.
8. Use a 5/16" drill bit to drill (2) holes through the pinch weld for the front and rear Support Brackets.
NOTE: Drill the holes as far away from the bottom edge of the pinch weld as possible. **IMPORTANT:** Do not drill through the welds in the pinch weld if possible.

IMPORTANT! Any cutting or drilling tool may break or shatter. Government regulations require safety glasses & equipment at all times when cutting or drilling.

9. Attach the top of the Support Brackets to the outside of the pinch weld with (2) 8mm x 25mm Hex Bolts, (4) 8mm x 16mm Small Flat Washers and (2) 8mm Nylon Lock Nuts, **(Figure 12)**. Reinstall the Running Board. Level, adjust and tighten all hardware.
10. Place the short driver side Running Board on top of the (2) Brackets. Slip (4) 6mm T-bolts into each bottom channel **(Figure 21)**. Carefully position the Running Board onto the (2) Mounting Brackets. **IMPORTANT:** Do not slide, (front to back), the Running Board on the Brackets or damage to the finish may result. Attach the Running Board to the Mounting Brackets with (2) 6mm T-bolts, (2) 6mm flat washers and (2) 6mm lock nuts **(Figures 22)**. Do not tighten at this time. Level and adjust the Running Board properly and tighten all hardware.
11. Move to the passenger side of the vehicle, **(Figure 13)**. Repeat **Steps 1—3** to attach the passenger side front Bracket, **(Figures 14 & 15)**. Repeat **Step 6** to attach (1) of the (5) identical Support Brackets.
12. Continue to the #2 mounting location, **(Figure 16)**. Repeat **Steps 5 & 6** to attach the #2 Mounting Bracket, **(Figure 17)**. Repeat to install the #3 and #4 (rear) Brackets, **(Figures 18—20)**.
13. Place the long Passenger side Running Board on top of the (4) Brackets. Slip (8) 6mm T-bolts into each bottom channel **(Figure 21)**. Carefully position the Running Board onto the (4) Mounting Brackets. **IMPORTANT:** Do not slide, (front to back), the Running Board on the Brackets or damage to the finish may result. Attach the Running Board to the Mounting Brackets with (2) 6mm T-bolts, (2) 6mm flat washers and (2) 6mm lock nuts **(Figures 22)**. Do not tighten at this time.
14. Repeat **Steps 8&9** to drill and attach the (4) Support Brackets to the pinch weld.
15. Level and adjust the Running Board properly and tighten all hardware.
16. Do periodic inspections to the installation to make sure that all hardware is secure and tight.

To protect your investment, wax this product after installing. Regular waxing is recommended to add a protective layer over the finish. Do not use any type of polish or wax that may contain abrasives that could damage the finish.

For Polished Finishes: Aluminum polish may be used to polish small scratches and scuffs on the finish. Mild soap may be used also to clean the Running Board.

For black finishes: Mild soap may be used to clean the Running Board.

Driver/left Side Installation Pictured

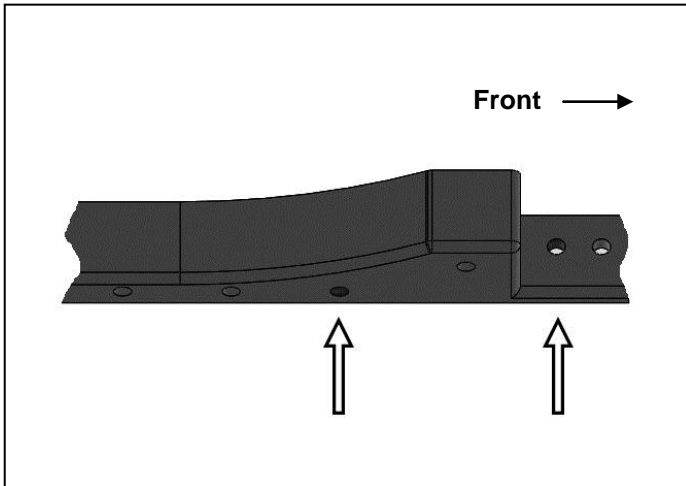

(Fig 1) Driver side front and rear mounting locations



(Fig 2) 8mm Bolt Plate with Plastic Retainer

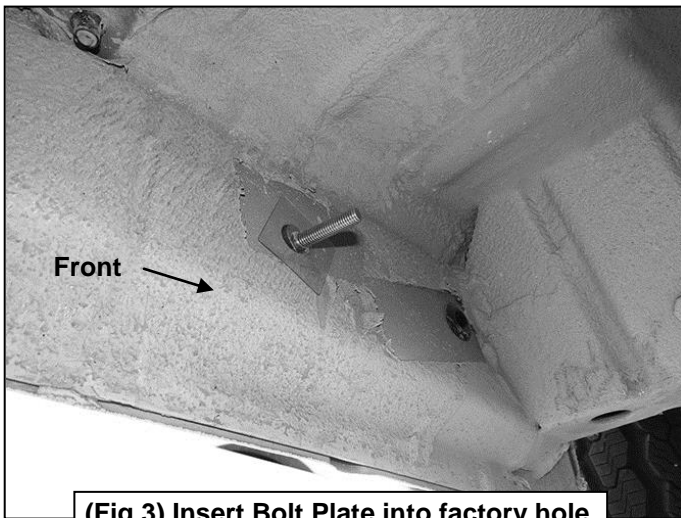

(Fig 3) Insert Bolt Plate into factory hole

8mm Large Flat Washer
8mm Lock Washer
8mm Hex Nut

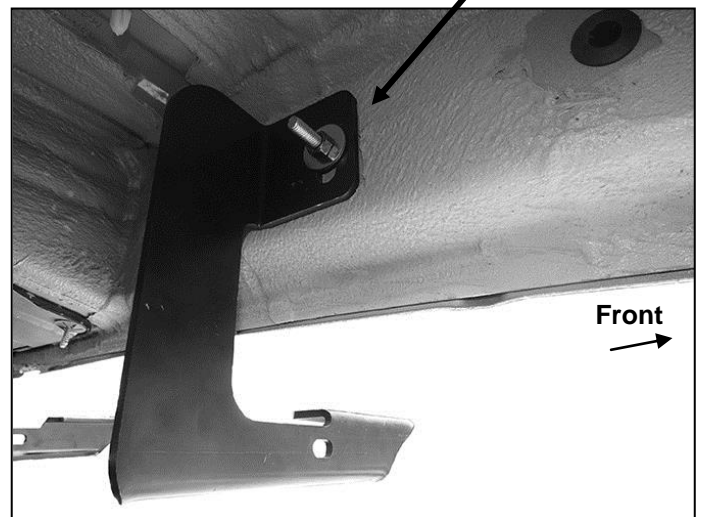

(Fig 4) Driver side front Bracket pictured

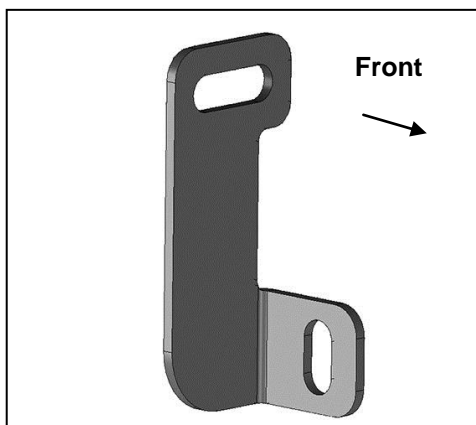

(Fig 5) Unique driver side front Support Bracket

Driver/left Side Installation Pictured

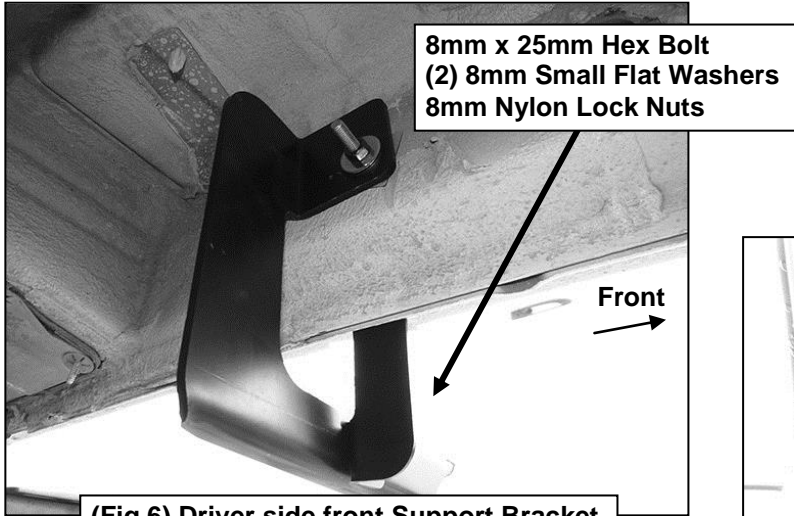

(Fig 6) Driver side front Support Bracket

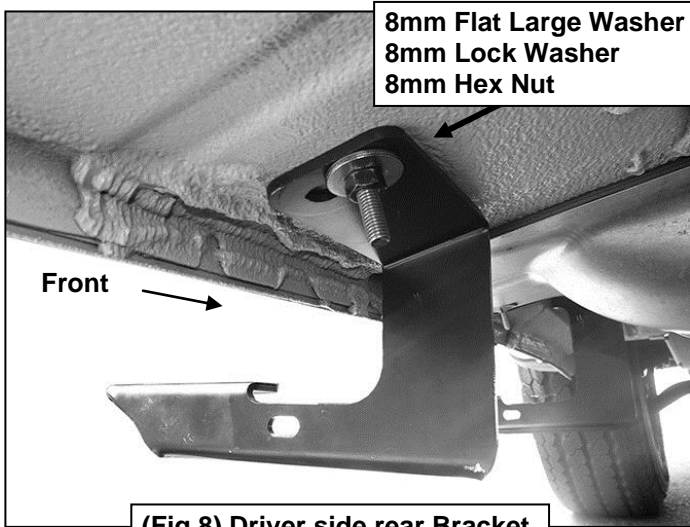

(Fig 8) Driver side rear Bracket

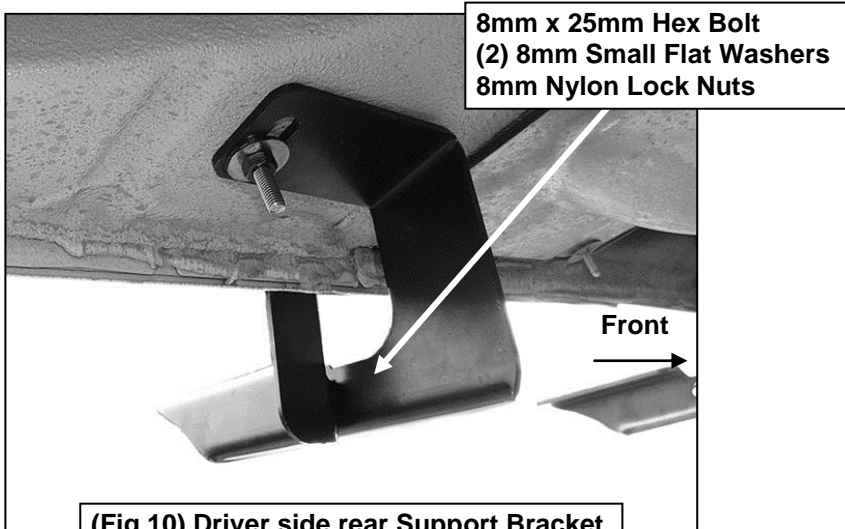

(Fig 10) Driver side rear Support Bracket

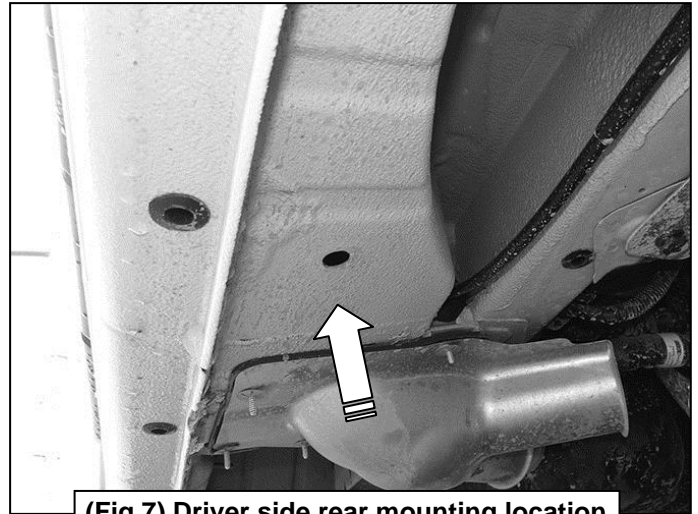

(Fig 7) Driver side rear mounting location

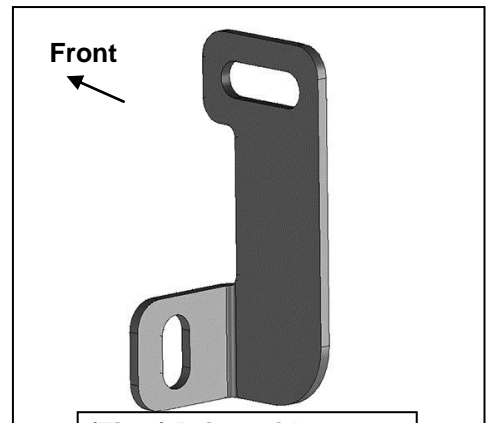

(Fig 9) Driver side rear Support Bracket (1 of 4)

IB(6",5",4")RUNNING BOARD
2014-18 RAM PROMASTER VAN 139" & 159" WHEELBASE (FULL SIZE)
Driver/left Side Installation Pictured



Fig 11

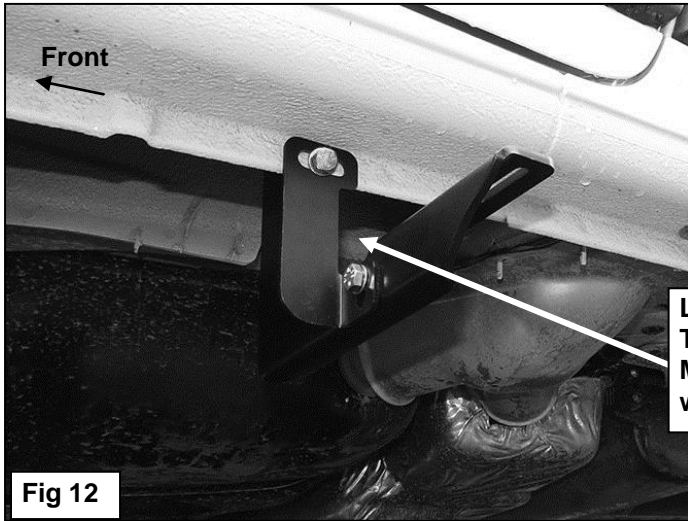
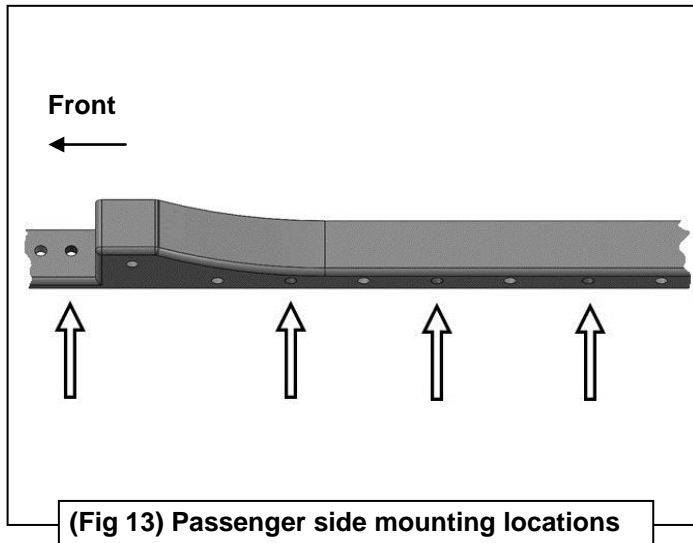

Fig 12

Level and adjust the Running Board.
Temporarily remove the running board.
Mark and drill 5/16" hole through pinch
weld for each Support Bracket

Passenger/right Side Installation Pictured

- (2) 8mm x 25mm Hex Bolts
- (2) 8mm Lock Washers
- (2) 8mm Flat Washers



(Fig 13) Passenger side mounting locations

8mm Bolt Plate
Plastic Retainer

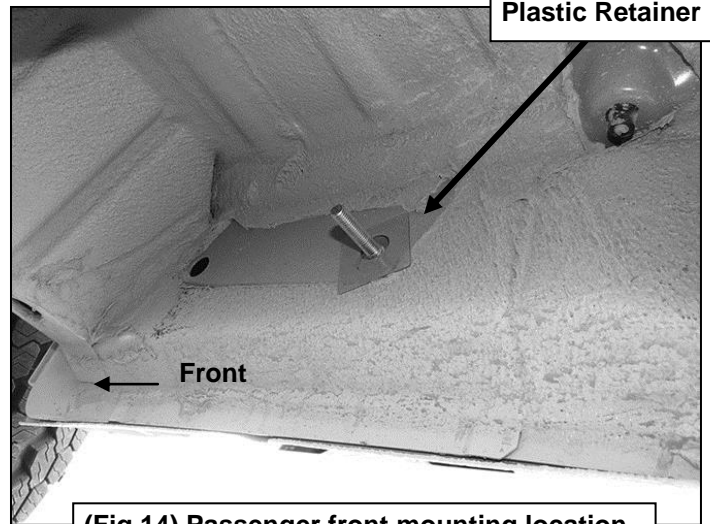

(Fig 14) Passenger front mounting location

Passenger/right Side Installation Pictured

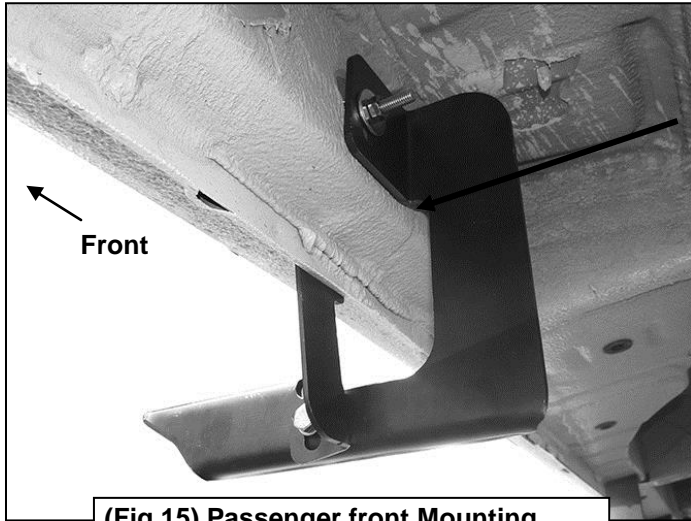

(Fig 15) Passenger front Mounting Bracket and Support Bracket installed

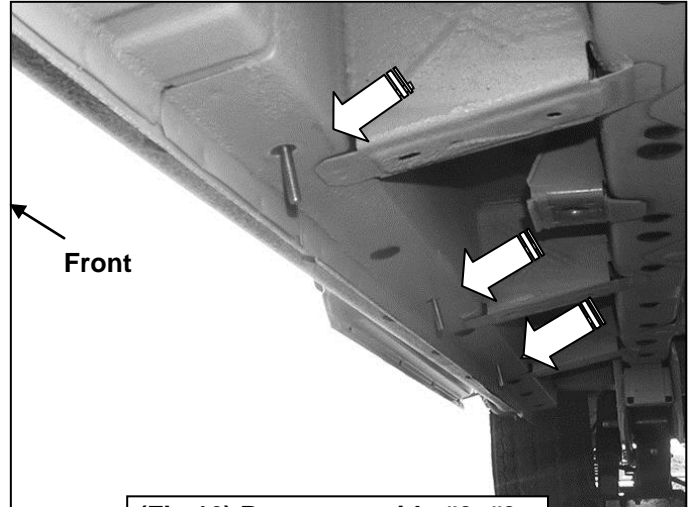

(Fig 16) Passenger side #2, #3 and rear mounting locations



(Fig 17) Passenger side #2 Bracket installed

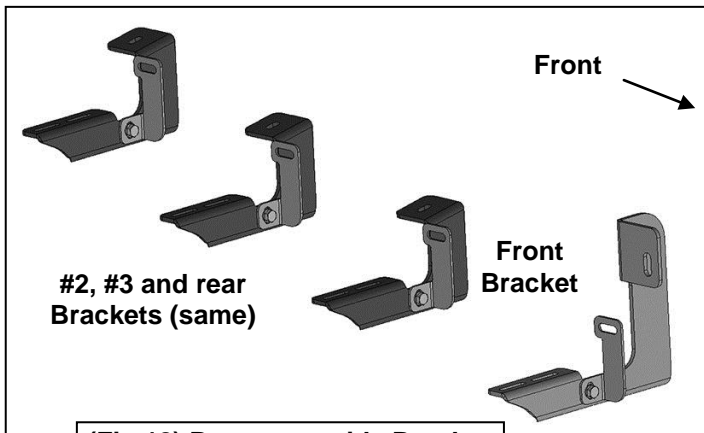

(Fig 18) Passenger side Bracket layout w-Support Brackets

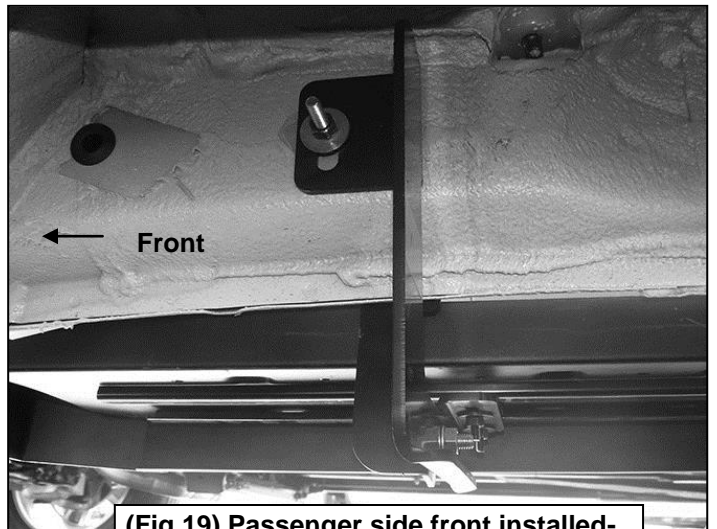

(Fig 19) Passenger side front installed- mark to drill through pinch weld

Passenger/right Side Installation Pictured

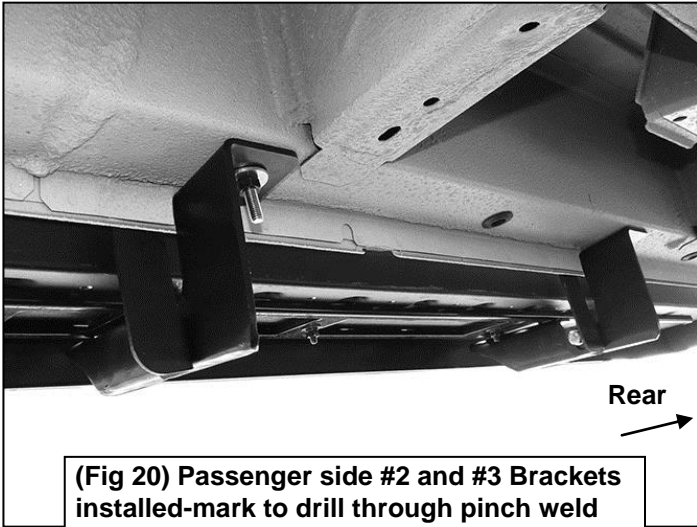

(Fig 20) Passenger side #2 and #3 Brackets installed-mark to drill through pinch weld



(Fig 21) Slip 6mm T-bolts into the bottom channel

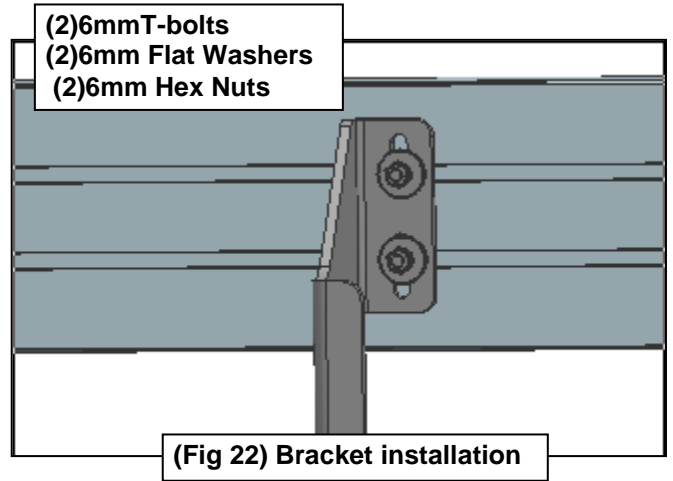

(Fig 22) Bracket installation