

# Installation Instructions for IB04EBJ6

by APS Auto Parts Specialist Inc.

Application: For 2009-2018 Dodge Journey  
Estimated Time: 1 to 2 hours



Disclaimer: Instructions intended for persons aged 18+ please do not attempt without adult supervision. Instructions are not intended to replace professional installation. Damage from improper installation, misuse or modification to the product voids the manufacturer's warranty.

**PARTS LIST:**

Item	Qty	Description	Item	Qty	Description
#1	2	Running Board (use for left or right)	#15	4	12mm Hex Nuts
#2	1	Driver/Left Front Mounting Bracket(DFM)	#16	2	10mm Lock Washers
#3	1	Passenger/Right Front Mounting Bracket(PFM)	#17	2	10mm x 30mm x 2.5mm Flat Washers
#4	1	Driver/Left Center Mounting Bracket(DCM)	#18	2	10mm Hex Nuts
#5	1	Passenger/Right Center Mounting Bracket(PCM)	#19	6	8mm x 25mm Hex Bolts
#6	1	Driver/Left Rear Mounting Bracket(DRM)	#20	6	8mm Lock Washers
#7	1	Passenger/Right Rear Mounting Bracket(PRM)	#21	12	8mm x 24mm x 2mm Flat Washers
#8	3	Driver/Left Support Brackets(DFS/DCS/DRS)	#22	6	8mm Hex Nuts
#9	3	Passenger/Right Support Brackets(PFS/PCS/PRS)	#23	12	6mm T-Bolts
#10	2	10-1.5mm x 35mm Button Head Bolt Plates (Center Bracket)	#24	6	6mm x 20mm Button Head Bolts
#11	2	12-1.75mm x 40mm Narrow Bolt Plate (for rear bracket-5/8" wide)	#25	24	6mm x 22mm OD x 2.0mm Flat Washers
#12	2	12-1.75mm x 35mm Wide Bolt Plate (for front bracket-13/16" wide)	#26	18	6mm Nylon Lock Nuts
#13	4	12mm Lock Washers			
#14	4	12mm x 32mm x 3mm Flat Washers			

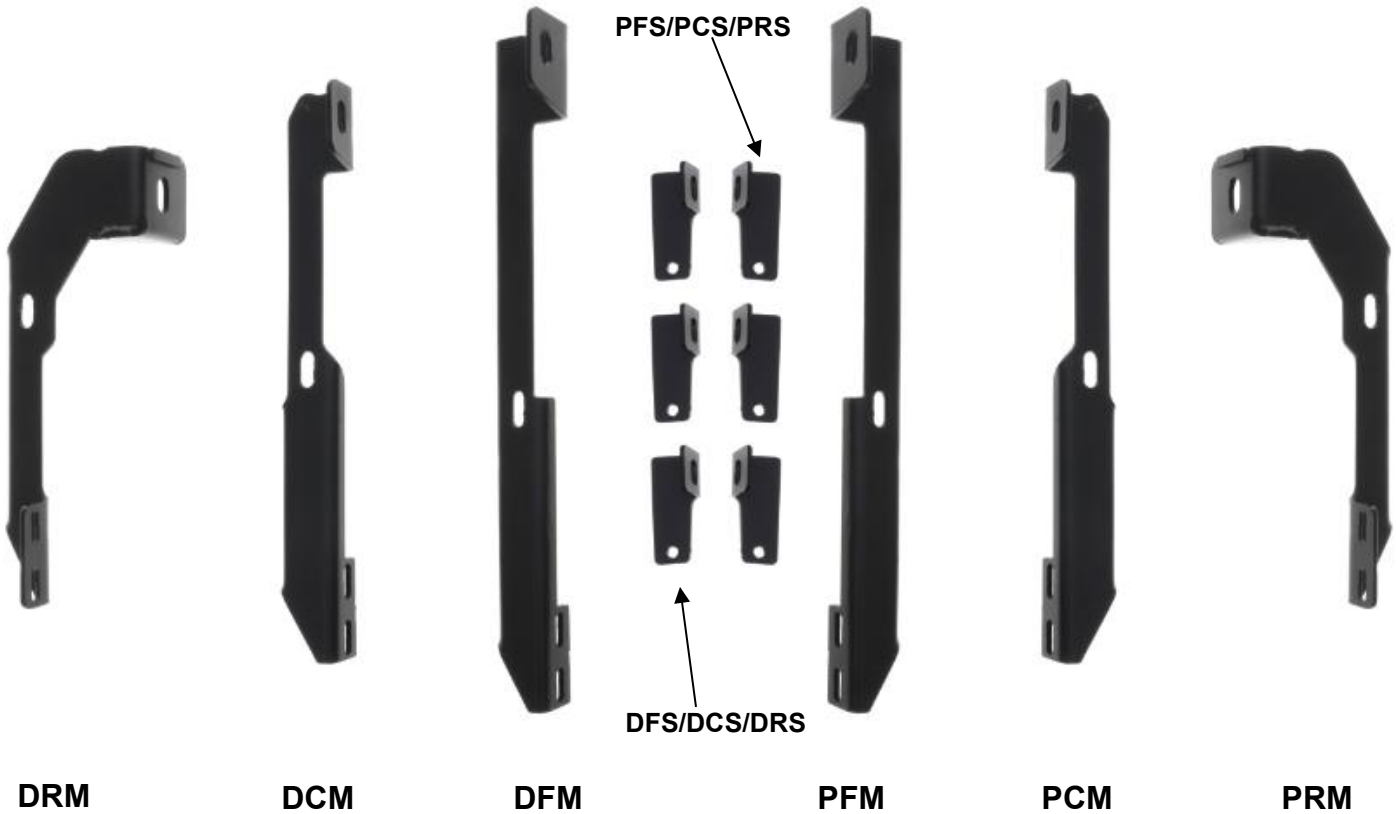

**PROCEDURE:**

1. **REMOVE CONTENTS FROM BOX. VERIFY ALL PARTS ARE PRESENT. READ INSTRUCTIONS CAREFULLY BEFORE STARTING INSTALLATION. DRILLING IS REQUIRED. ASSISTANCE IS RECOMMENDED.**
2. Starting toward the front of the driver/left side of the vehicle, locate the factory oval hole in the bottom of the inner frame channel, **(Figure 12)**. Insert (1) 12mm x 35mm Wide Bolt Plate into the factory hole, **(Figures 2A & 2B)**. Select the driver side Front Bracket. Attach the Bracket to the Bolt Plate with (1) 12mm Flat Washer, (1) 12mm Lock Washer and (1) 12mm Hex Nut, **(Figure 3)**. Do not tighten hardware at this time.
3. Select (1) driver side Support Bracket, **(Figure 4A)**. Bolt the Support Bracket to the front of the Mounting Bracket with (1) 8mm x 25mm Hex Bolt, (2) 8mm Flat Washers, (1) 8mm Lock Washer and (1) 8mm Hex Nut, **(Figure 4B)**. Snug but do not tighten hardware at this time.
4. Move along the side to the center mounting location directly below where the front and rear doors meet. Locate the square hole in the bottom of the frame channel, **(Figure 5)**. Insert (1) 10mm Button Head Bolt Plate into the factory hole, **(Figures 6A & 6B)**. Attach the Center Mounting Bracket to the Bolt Plate with (1) 10mm Flat Washer, (1) 10mm Lock Washer and (1) 10mm Hex Nut, **(Figure 7)**. Snug but do not tighten hardware at this time.
5. Select (1) driver side Support Bracket, **(Figure 4A)**. Bolt the Support Bracket to the front of the Mounting Bracket with (1) 8mm x 25mm Hex Bolt, (2) 8mm Flat Washers, (1) 8mm Lock Washer and (1) 8mm Hex Nut, **(Figure 8)**. Snug but do not tighten hardware at this time.
6. Continue along the side of the vehicle toward the rear tire. Locate the factory oval hole in the floor panel, **(Figure 9)**. Insert (1) 12mm x 40mm Narrow Bolt Plate into the hole, **(Figures 10A & 10B)**. Rotate the Bolt Plate 90-degrees or until it stops so that the plate is across, not inline with the oval hole.
7. Attach the driver side Rear Mounting Bracket to the Bolt Plate with (1) 12mm Flat Washer, (1) 12mm Lock Washer and (1) 12mm Hex Nut, **(Figure 11)**. Snug but do not tighten at this time.
8. Repeat **Steps 3 & 5** to bolt the Support Bracket to the front of the Mounting Bracket, **(Figure 11)**.
9. Carefully unwrap and select Running Board. Insert (6) 6mm T-Bolts into the slots in the end of the channels, (3 T-Bolts per slot), on the bottom of the Running Board, **(Figure 12)**. Hold the Running Board up in the approximate position and slide the T-Bolts down the slots to line up with the Brackets. Tilt the Running Board up at a slight angle to clear the slots in the Brackets. Secure the Running Board to the Brackets with (6) 6mm Flat Washers and (6) 6mm Hex Nuts, **(Figure 13)**, Do not fully tighten hardware at this time.
10. Level and adjust the Running Board and tighten all Mounting Bracket to vehicle hardware. Line up the Support Brackets with the back of the pinch weld. Use clamps to temporarily attach the Support Brackets to the pinch weld, **(Figures 14 & 15)**. Align the Running Board and mark the location of the (3) Support Brackets onto the back of the pinch weld, **(Figures 4B, 8 & 13)**. Once all (3) locations are marked, remove the Running Board. Loosen the Brackets and move them out of the way. **VERY IMPORTANT:** Do not drill too close to the edge of the pinch weld.
11. Drill a 1/4" hole through the pinch weld at the front Bracket location. Move the front Bracket and Support Bracket back into position. Attach the Support Bracket to the pinch weld with (1) M6 x 20mm Button Head Bolt, (2) M6 Flat Washers and (1) M6 Nylon Lock Nuts, **(Figure 16)**. Repeat this Step to install the Center and Rear Support Brackets.
12. Reinstall the Running Board, align, adjust as necessary and tighten all hardware. **NOTE: Torque all M6 nylon lock nuts to 7 lb-ft.**
13. Repeat **Steps 2 – 12** for passenger side Running Board installation.
14. Do periodic inspections to the installation to make sure that all hardware is secure and tight.

**To protect your investment**, wax this product after installing. Regular waxing is recommended to add a protective layer over the finish. Do not use any type of polish or wax that may contain abrasives that could damage the finish.

**For stainless steel:** Aluminum polish may be used to polish small scratches and scuffs on the finish. Mild soap may be used also to clean the Running Board.

**For gloss black finishes:** Mild soap may be used to clean Running Board.

### Driver Side Installation Pictured

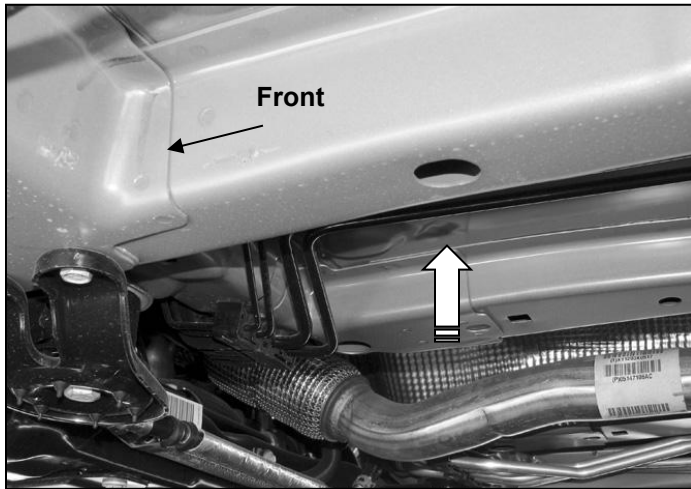

**(Fig 1) Driver/left front mounting location pictured**

12mm Flat Washer  
12mm Lock Washer  
12mm Hex Nut

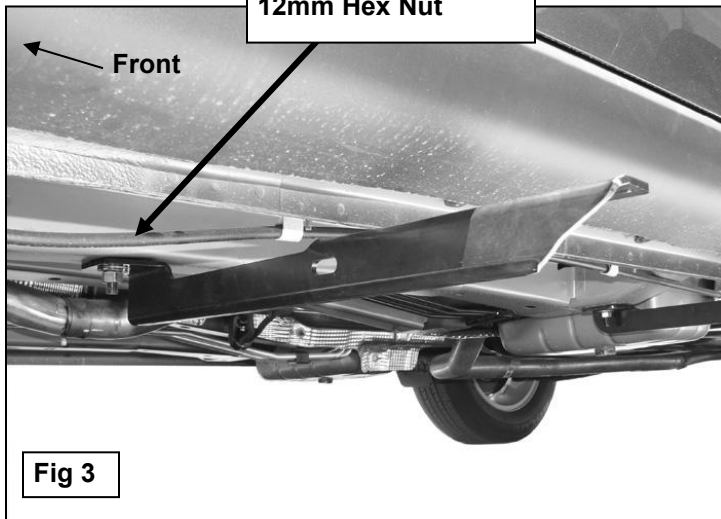

**Fig 3**



**(Fig 2A) 12mm x 35mm  
Wide Bolt Plate**

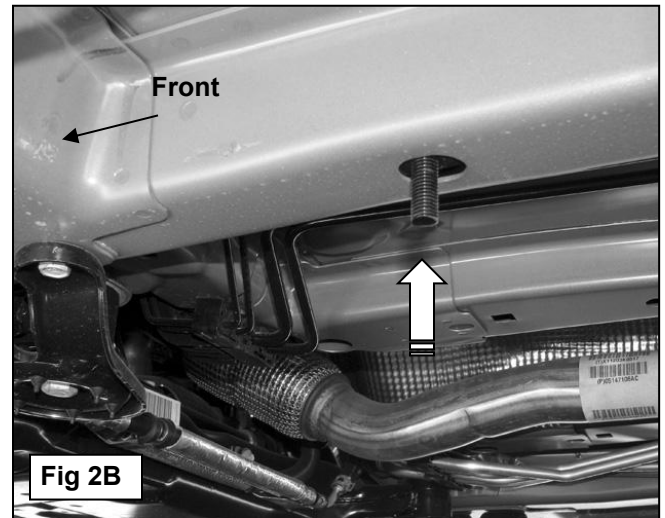
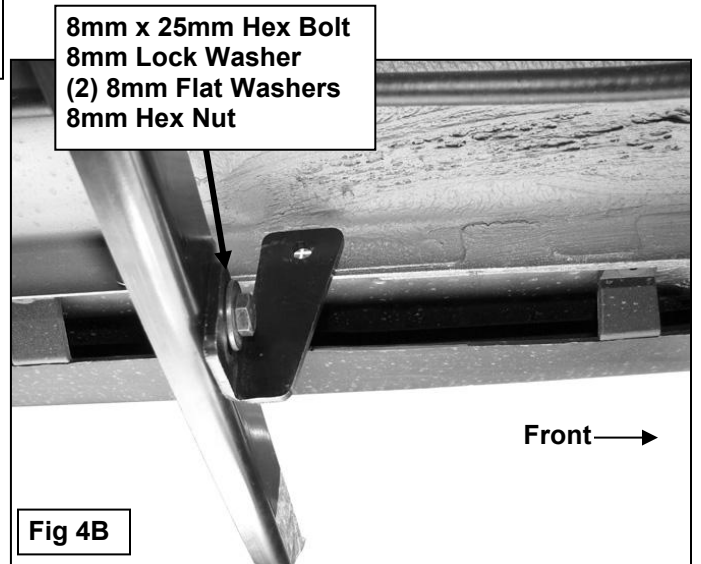

**Fig 2B**

Do not drill any mounting  
locations until after all Brackets  
have been installed and adjusted



**(Fig 4A) Driver/left  
Support Bracket (1 of 3)**



8mm x 25mm Hex Bolt  
8mm Lock Washer  
(2) 8mm Flat Washers  
8mm Hex Nut

**Fig 4B**

### Driver Side Installation Pictured

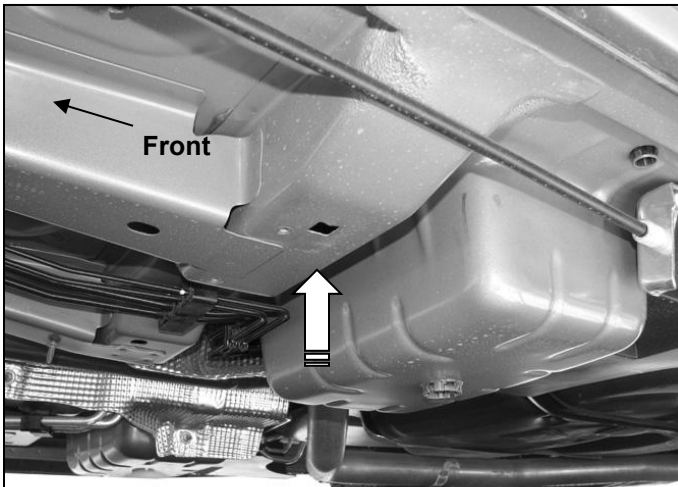

(Fig 5) Driver/left center mounting location pictured

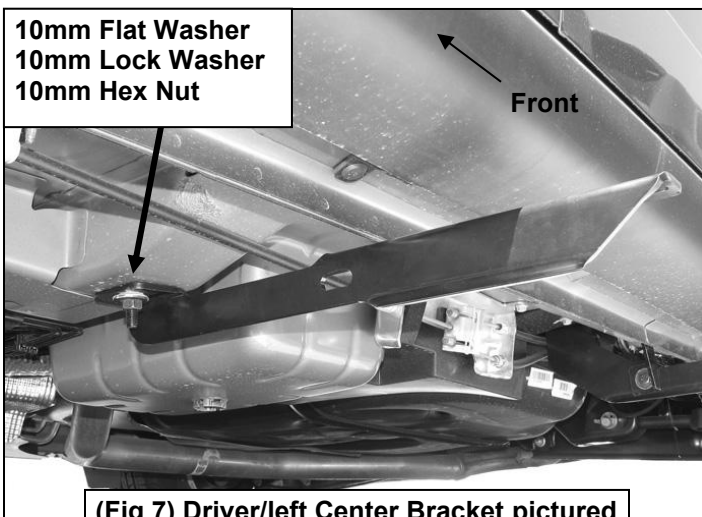

(Fig 7) Driver/left Center Bracket pictured

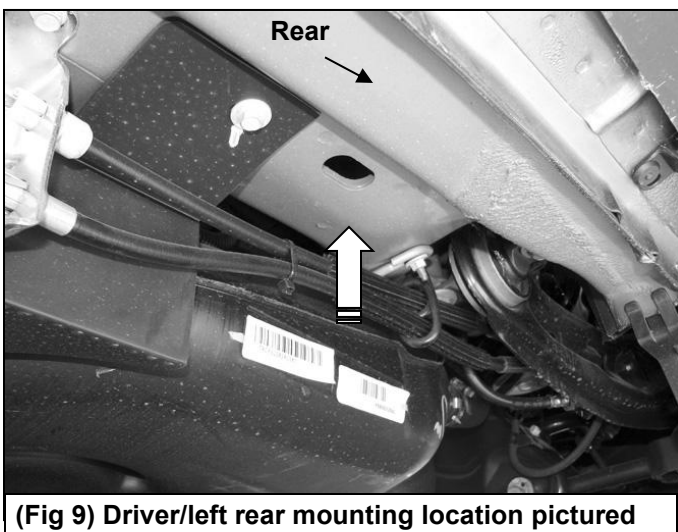

(Fig 9) Driver/left rear mounting location pictured



(Fig 6A) 10mm x 35mm Small Button Head Bolt Plate

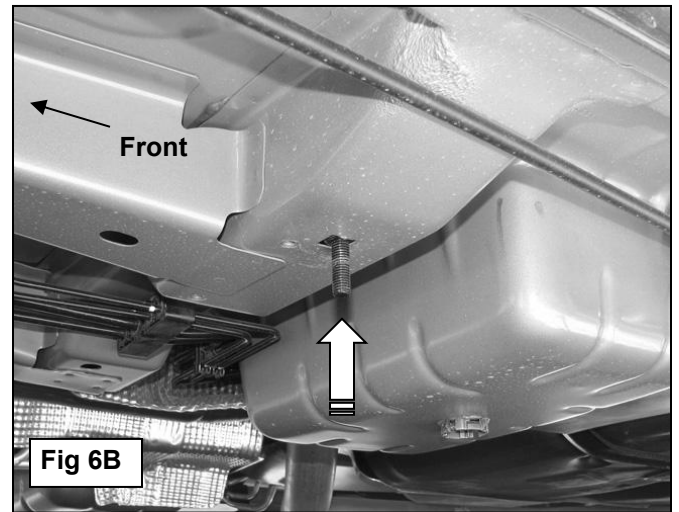
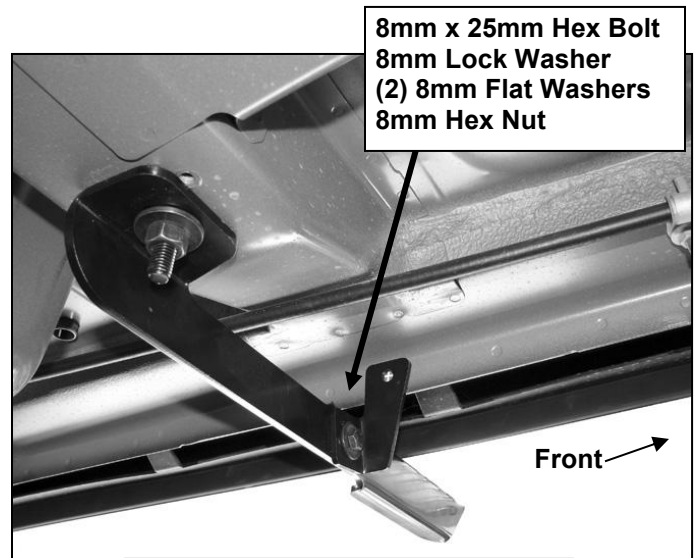

Fig 6B



(Fig 8) Driver/left Center Bracket pictured with Support Bracket

Do not drill any mounting locations until after all Brackets have been installed and adjusted

**Driver Side Installation Pictured**



**(Fig 10A) 12mm x 40mm  
Narrow Bolt Plate**

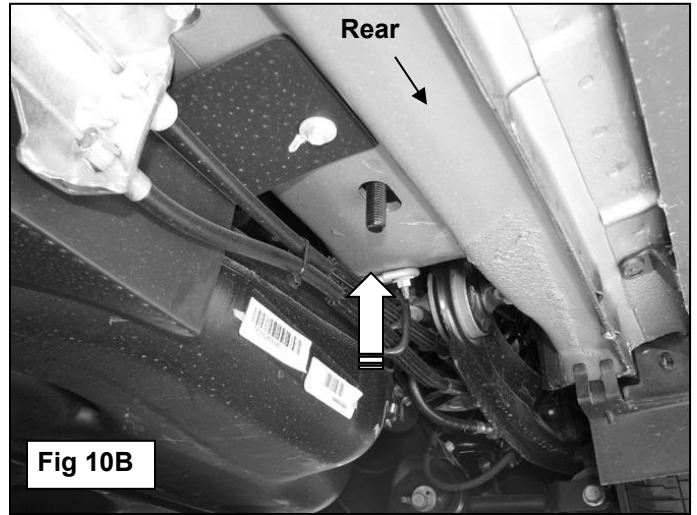

**Fig 10B**

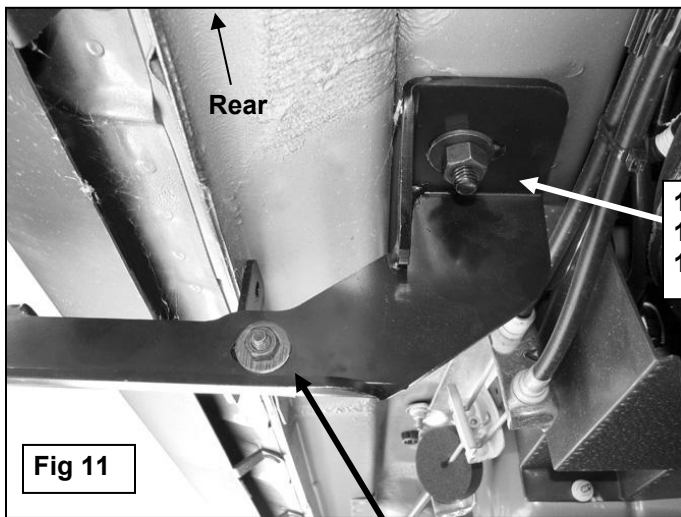

**Fig 11**

**12mm Flat Washer  
12mm Lock Washer  
12mm Hex Nut**

**8mm x 25mm Hex Bolt  
8mm Lock Washer  
(2) 8mm Flat Washers  
8mm Hex Nut**

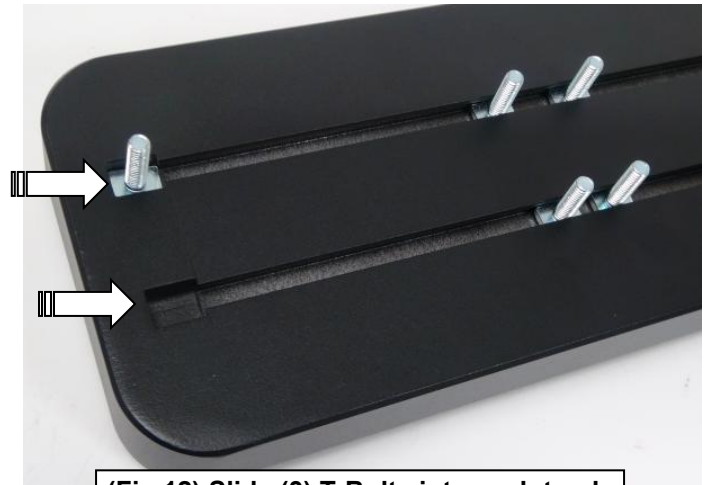

**(Fig 12) Slide (3) T-Bolts into each track**

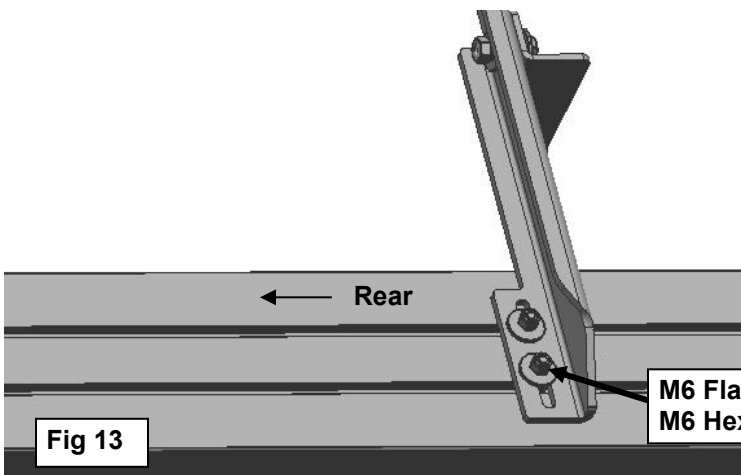
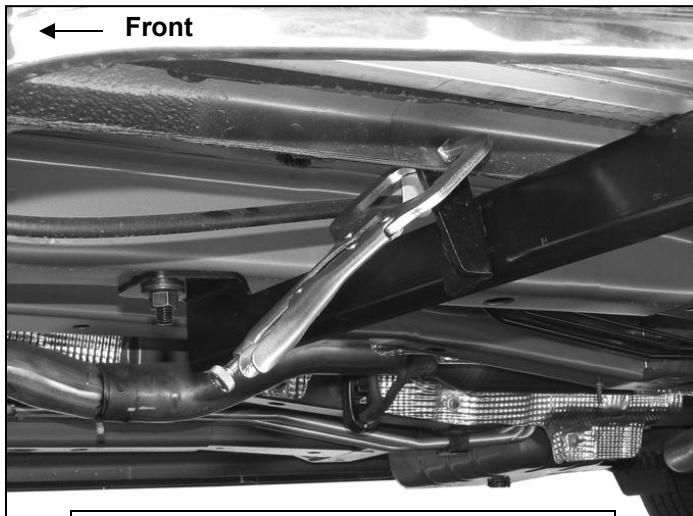

**Fig 13**

**M6 Flat Washers  
M6 Hex Nuts**

**Do not drill any mounting  
locations until after all Brackets  
have been installed and adjusted**

### Driver Side Installation Pictured



(Fig 14) Driver/left front Bracket pictured

M6 x 20mm Button Head Bolt  
(2) M6 Flat Washers  
M6 Nylon Lock Nut

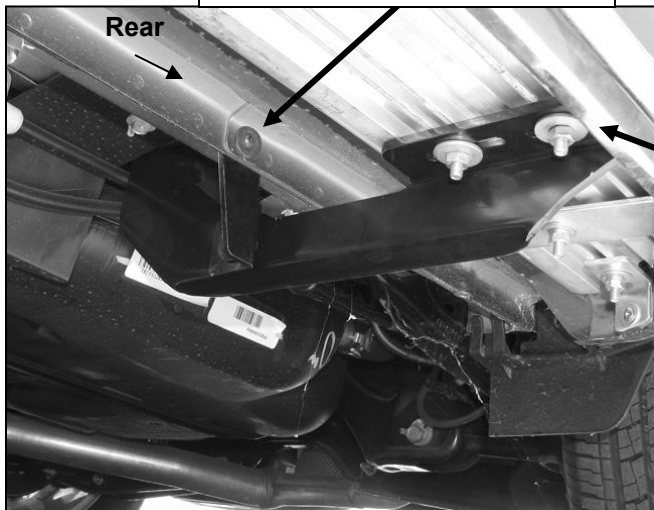

(Fig 16) Driver/left rear Bracket pictured

Use clamps or place stands under the Brackets to help hold the Brackets in proper position. Once aligned and adjusted, mark the locations of all (3) Support Brackets. Drill locations with a 1/4" drill bit. Do not drill too close to the edge of the pinch weld

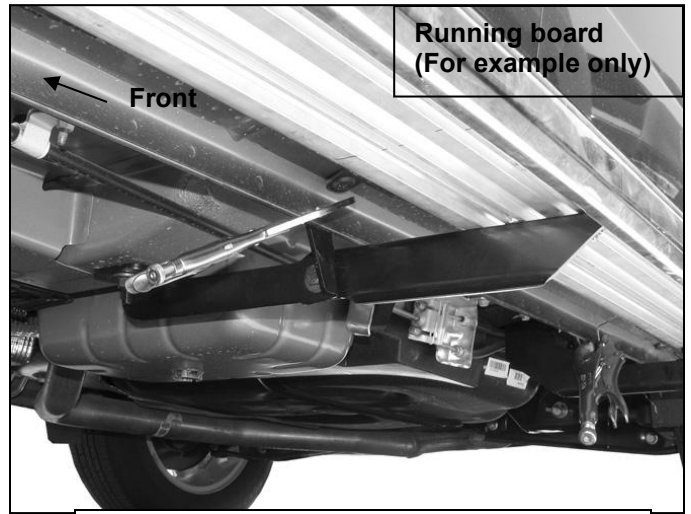

(Fig 15) Driver/left center Bracket pictured

M6 Flat Washers  
M6 Lock Washers  
M6 Hex Nuts



Installation Complete