

LEADER IN LOAD SECUREMENT INNOVATION

50

SINCE
1969



**ANCERA
CARGO**



EVERYTHING YOU NEED FROM A TO Z TO MOVE ANYTHING FROM A TO B.

WELCOME TO OUR CATALOG.

From anchor points to zinc coated hardware and everything in-between, Ancra's world class cargo restraint systems equip you to take to the road with a stable, secure load. Whether your cargo calls for standard or heavy-duty restraint, in this comprehensive catalog you'll find dependable flatbed, interior van solutions, lifting slings, auto transport products, hardware, and utility tie downs to meet all your load securement requirements and help ensure your compliance with CSA.

THIS CATALOG IS ORGANIZED TO SAVE YOU TIME AND EFFORT.

There are eight major product sections:

- Flatbed
- Interior Van
- Safety and Emergency Equipment
- Auto Transport
- Lifting Slings
- Utility Tie Downs
- General Hardware & Webbing
- General Information

Color-coded pages in each section help you find the desired category quickly. All products are presented with photos and complete descriptions, capacities and sizes. **Drawings** and **sidebar how-tos** give you additional details, as well as **web links** and **Quick Response (QR) Codes** that connect you to dynamic online information.



Trucker-Friendly Pages

If you're looking for a specific product, it's easy to find in our Index listings. Whether you're searching by part number or product name, you can find what you're looking for in our Numerical Index starting on page 112, or our Alphabetical Index on page 123.

Product pages offer comprehensive product information and more:

Trucker Tips: Handy, helpful tips in boxes framed in black and yellow stripes.

Part Numbers: Listed in boldfaced type followed by technical specifications.

Warnings: Vital Information regarding product use or hazards on the road highlighted in color boxes.



Did you know?: Facts and figures, historical industry notes stand out with their blue background.

QR Codes: Quick Response icons when scanned on your smart phone can connect you to videos, demonstrations and details.

Links: Take you to website pages for deeper information.

SAFETY IN NUMBERS TIMES 3

Solid parent organization

Ancra Cargo has continuous access to professional services, financial and insurance partners and best practices policies, plus the further advantage of a solid parent organization, The Heico Companies, with annual sales approaching \$3-billion.

Safety factors

It doesn't take a numbers person to appreciate the built-in safety factor of reputable products. At Ancra, we use our own in-house testing facilities as well as independent sources to test and retest our securement products. It's a process that begins with initial design concepts and continues through the final manufacturing.

It doesn't end there. We constantly spot test finished products to make sure they meet quality cargo control standards day after day. We even test and evaluate products that have been in service for signs of corrosion and fatigue. When you see the working load limits permanently marked on Ancra winches, you can be sure those numbers will be met, and more.

In-service record

There's a third way we ensure safety in numbers. Serving the trucking industry for decades we have hundreds of thousands of reliable products working hard everyday. Truckers know what's good.

OUR SAFETY TESTING PROCESS



ABRASION TESTER CONFIRMS THE STRENGTH OF ANCRA STRAPS. Random webbing samples are abrasion tested per ASTM D6770-097 then load tested for its ability to withstand accelerated wear.



TENSILE TEST EQUIPMENT CHECKS ANCRA WEBBING AND HARDWARE FOR LOAD CAPACITY USING UP TO 50,000 LBS. OF FORCE. If a product doesn't meet the minimum required capacity, the lot is rejected.

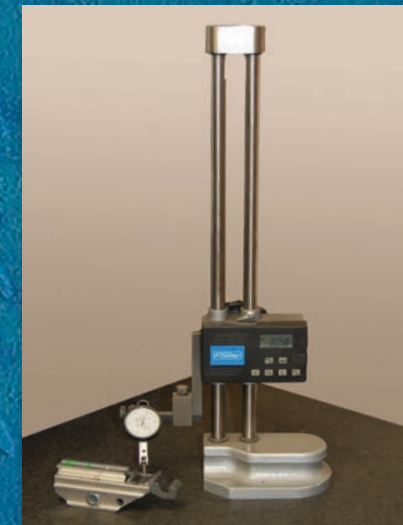

TOLERANCES. During the process of first article inspection, Ancra measures crucial tolerances with a granite table and height stand. This assures the product is built to design specs.



HIGH DEFINITION COMPARATOR verifies dimensions. Ancra products are inspected for accuracy and proper fit with mating parts that will assure trouble-free performance.



COLOR-CODED PRODUCT SECTION

Flatbed Solutions

Web Winches	.2, 3, 4, 5, 6
Combination Winches	.7
Cable Winches	.7
Lashing Winches	.8
PortaWinch™ & Porta Anchor™	.9
Winch Dimension Chart	.10
Winch Track	.11
SilverCap™ OverDrive™ Ratcheting Cap	.12
Ergo Bars	.13
Winch Bars and D-Rings	.14
Hooks & Web Winders	.15
GlideLock® and Coil Rack	.16
Corner and Web Protectors	.17, 18
X-Treme Guard	.18
Flatbed Trailer Ladder	.19
Corner Protector Placement Tool	.19
Tarp Ties, Rubber Rope & Hooks	.20
Transport Chain & Hardware	.21, 22, 23, 24, 25
EZ Binder	.25
Chain Load Binder & Accessories	.26, 27
Floor Chain Tie Downs	.27
Winch Strap Assemblies, X-TREME	.28, 29, 30
Winch Strap Assemblies, Standard	.31, 32, 33
Roll On/Off Container Straps	.33
Ratchet Strap Assemblies, X-TREME	.34, 35
Ratchet Strap Assemblies, Standard	.36, 37, 38
Ratchet Strap Replacements	.39, 40
Gear Drive Tensioner	.40
Cable & Chain Anchors, X-Treme Rope Tie Down, Toss 'N Tie, 5th Wheel Release Hook	.41

Interior Van Solutions

Vers-A-Deck®	.44
Lift-A-Deck® II	.45, 46, 47, 48, 49, 50
Logist-A-Panel	.51
Poly Deckboard	.51
Security Divider & Deckboard	.52
Knock Down Pallet Deck	.53
Pallet Deck	.53
Retract-A-Roll® III	.54
Logistic Track	.55, 56, 57
Beams, Bars & Hoops	.58, 59
Shoring Bars	.59
Beam Sockets	.59
Cargo Sta®	.60
Hoop Set for Cargo Sta®	.60
Heavy-Duty Jack Bars	.60
Cargo Bar Holder	.62
Tie Offs	.62
Door Pull Straps	.62
Trailer Fittings	.63
Transmat®	.63
Driver Assist Straps	.63
Trailer Access Steps	.64
Tension Limiting Ratchet Assemblies	.65
Cam Buckle Strap Assemblies	.66, 67
Plate Trailer Straps	.68

Ratchet Buckle Straps	.68
Custom Nets	.69

Safety and Emergency Equipment

Flag & Banners	.72, 73
Lights & Reflectors	.74
Wearables	.74

Auto Transport Solutions

Car Hauler Straps	.76
Car Tie Downs	.77, 78
Dolly Straps	.77
Transit Straps	.77
Tire Bonnets	.78
Lashing Winches	.78

Lifting Solutions

Round Slings	.80
Eye to Eye Web Slings	.81, 82

Utility Tie Downs

Ratchet Strap Assemblies	.84
Cam Strap Assemblies	.84
Packaged Straps	.85
Trackstar Motorcycle Wheelchock	.85
Pickup Truck Cargo Nets	.86

General Hardware & Webbing

Ratchet Buckles	.88, 89, 90
Overcenter Buckles	.90
Cam Buckles	.91
Roller Buckle	.91
3-Bar Slide Adjuster	.91
Wire Hooks	.92
Flat Hooks	.93
Snap Hooks	.94
Rings	.94
Bolt Plates	.95
Track Fittings	.96, 97
Chain Attachments	.97
Clevis Hooks	.98
RTJ Cluster Hook	.98
Chain Hardware	.99, 100
Webbing	.101
Heavy Duty Aircraft Style Track	.102
Heavy Duty Beveled Aircraft Style Track	.102
Bottle Jacks	.103
Merchandising	.104

General Information

Specifications/Warranty	.106
Industry Standards	.107, 108
Replacement Criteria	.109
Glossary	.110
Trade Association, Resources	.111
Index by Product Number	.112
Index by Product Name	.123

Ancra's trusted straps and high performance winches, tie downs, and chain assemblies are engineered to meet the challenges of today's highways. If it wears the Ancra name, it can be trusted.

- Long wearing heavy-duty components in every assembly
- Weather resistant, performance proven products
- Specially engineered construction for maximum durability
- Quick and easy operation
- Products to meet your most demanding applications
- Custom products available to meet your unique needs

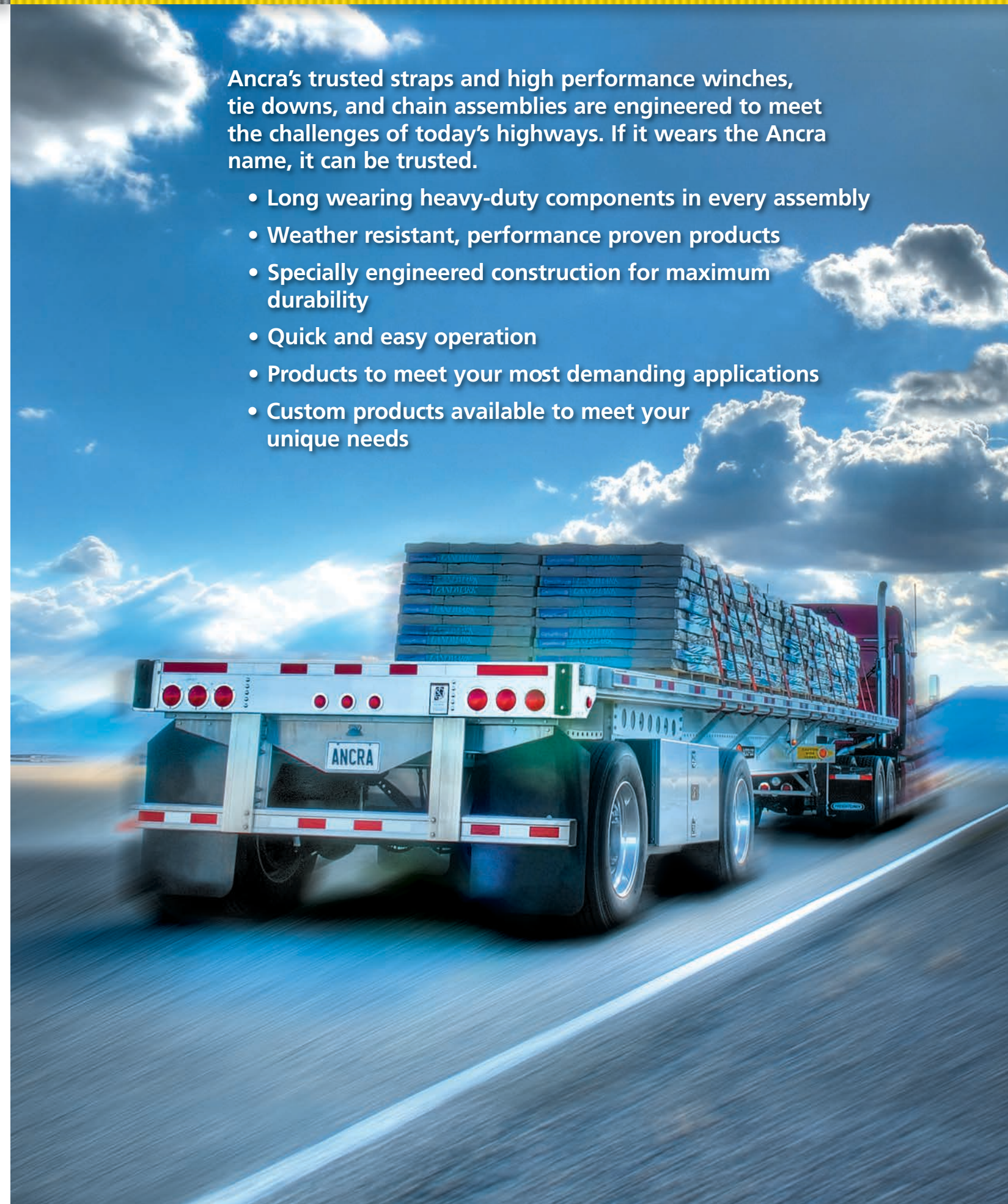

STRONGEST IN THE INDUSTRY

Ankra winches comply with FMCSA, WSTDA-T3 and Canadian Standard 905 regulations. Available in different base configurations to suit a variety of needs and load requirements.

All winches shown are right hand models. Left hand models may be available on special orders.

Black powder coat is the standard finish for all winches.

Smooth ground web slots prevent web wear.

Seamless solid steel mandrel.

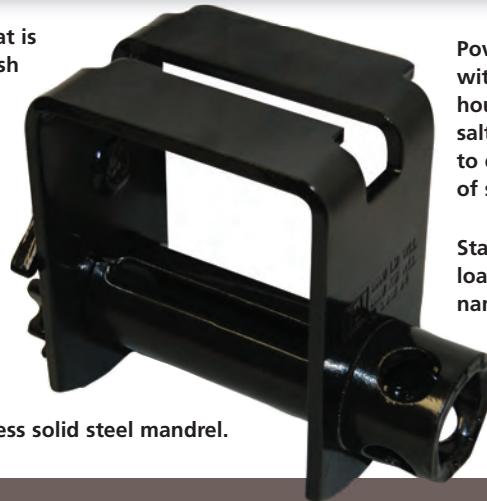

Powder coating withstands 250 hours of standard salt spray testing to ensure years of service.

Stamped working load limit and Ankra name certify quality.

High-strength alloy pawl pins.

WEB WINCHES

Bottom Mount



43563-10
Standard Weld-on
Weight: 8.6 lbs./3.9 kg.
WLL: 5,500 lbs./2,500 kg.



43563-10-RW
Standard Weld-on Ratchet Winch
Weight: 10.1 lbs./4.58 kg.
WLL: 5,500 lbs./2,500 kg.



43564-127
Web Storable Portable w/ 2SS
Weight: 11.1 lbs./5.0 kg.
WLL: 5,500 lbs./2,500 kg.



43564-147
Standard Portable w/ 2SS
Lighter 7mm heat treated frame
Weight: 7.7 lbs./3.5 kg.
WLL: 5,500 lbs./2,500 kg.



43564-147-RW
Standard Portable Ratchet Winch
Lighter 7mm heat treated frame
Weight: 9.2 lbs./4.17 kg.
WLL: 5,500 lbs./2,500 kg.



43564-167
Low Profile Portable w/ 2SS
Weight: 10.1 lbs./4.58 kg.
WLL: 5,500 lbs./2,500 kg.



43573-10
Web Storable Weld-on
Weight: 9.1 lbs./4.1 kg.
WLL: 5,500 lbs./2,500 kg.



43573-13
Web Storable Weld-on 4" Spool
Weight: 12.4 lbs./5.6 kg.
WLL: 5,500 lbs./2,500 kg.



48783-10
Weld-on Double Cap
Weight: 9.0 lbs./4.1 kg.
WLL: 5,500 lbs./2,500 kg.

WEB WINCHES

Side Mount Weld-on



43579-20
Low Profile Weld-on
Weight: 7.3 lbs./3.3 kg.
WLL: 5,500 lbs./2,500 kg.



41691-10
Leg Bracket Weld-on
Weight: 7.1 lbs./3.2 kg.
WLL: 5,500 lbs./2,500 kg.

DID YOU KNOW? About Winches

3-BAR: Designed for easy strap insertion during snow and ice conditions. Prevents the mandrel from freezing up.

PORTABLE: Versatile and meant for temporary installation, and can be placed along the trailer side frame.

SPOOL: Designed to reduce strap wear, spool discs guide and store the webbing into a single roll up to 30'.

STANDARD DOUBLE CAP: Incremental adjustment from both sides of the winch allows for clearance applications.

SLIDERS: Allow for easy positioning in the track, but lock into place when tension is applied to the strap. For use with Ankra C track 42357-11, -12 & -21 and Ankra double L track 49242-10-120 & 49789-10-102 or equivalent.

Sliders



43565-127
Web Storable
C Track Slider.
Lighter 7mm heat treated frame
Weight: 8.2 lbs./3.7 kg.
WLL: 6,000 lbs./2,730 kg.



43565-127-RW
Web Storable Bottom Mount
Ratchet Winch
C Track Slider
Lighter 7mm heat treated frame
Weight: 9.7 lbs./4.4 kg.
WLL: 6,000 lbs./2,730 kg.



43565-127-XZ
Web Storable
X-Treme Zinc Finish
C Track Slider
Lighter 7mm heat treated frame
Weight: 8.2 lbs./3.7 kg.
WLL: 6,000 lbs./2,730 kg.



43565-137
Standard Double Cap
C Track Slider. Lighter 7mm heat treated frame
Weight: 8.3 lbs./3.8 kg.
WLL: 6,000 lbs./2,730 kg.



43565-14
Web Storable w/ Side Washers
C Track Slider.
Weight: 8.6 lbs./3.9 kg.
WLL: 6,000 lbs./2,730 kg.
*43565-177 Standard height version also available.



Reduces weight per winch by 2 lbs. on average. Lighter weight reduces fuel expenses and allows for a greater payload. Heat treated material maintains strength.

WEB WINCHES

Sliders



43565-157
Standard Bottom Mount
C Track Slider. Lighter 7mm heat
treated frame
Weight: 7.6 lbs./3.5 kg.
WLL: 6,000 lbs./2,730 kg.



43565-157-RW
Standard Ratchet Winch
C Track Slider
Lighter 7mm heat treated frame
Weight: 9.1 lbs./4.1 kg.
WLL: 6,000 lbs./2,730 kg.



43565-157-XZ
Standard Bottom Mount
X-Treme Zinc Finish
C Track Slider
Lighter 7mm heat treated frame
Weight: 7.6 lbs./3.5 kg.
WLL: 6,000 lbs./2,730 kg.



49207-127
Web Storable
Double L Track Slider
Lighter 7mm heat treated frame
Weight: 6.8 lbs./3.09 kg.
WLL: 5,500 lbs./2,500 kg.



49207-127-RW
Web Storable Ratchet Winch
Double L Track Slider
Lighter 7mm heat treated frame
Weight: 8.3 lbs./3.8 kg.
WLL: 5,500 lbs./2,500 kg.



49207-127-XZ
Web Storable
Double L Track Slider
X-Treme Zinc Finish
Lighter 7mm heat treated frame
Weight: 6.8 lbs./3.1 kg.
WLL: 5,500 lbs./2,500 kg.



49207-137
Standard
Double L Track Slider
Lighter 7mm heat treated frame
Weight: 6.5 lbs./2.95 kg.
WLL: 5,500 lbs./2,500 kg.



49207-137-RW
Standard Ratchet Winch
Double L Track Slider
Lighter 7mm heat treated frame
Weight: 8.0 lbs./3.6 kg.
WLL: 5,500 lbs./2,500 kg.



49207-137-XZ
Standard
Double L Track Slider
X-Treme Zinc Finish
Lighter 7mm heat treated frame
Weight: 6.5 lbs./2.3 kg.
WLL: 5,500 lbs./2,500 kg.



To give your winches a longer working life, specify X-Treme Zinc for better corrosion protection than zinc-plated, paint or powder coated finishes.

WEB WINCHES

Sliders



49207-187
Low Profile
Double L Track Slider
Lighter 7mm heat treated frame
Weight: 6.2 lbs./2.8 kg.
WLL: 5,500 lbs./2,500 kg.



49207-187-RW
Low Profile Ratchet Winch
Double L Track Slider
Lighter 7mm heat treated frame
Weight: 7.7 lbs./3.5 kg.
WLL: 5,500 lbs./2,500 kg.



49207-187-XZ
Low Profile
Double L Track Slider
X-Treme Zinc Finish
Lighter 7mm heat treated frame
Weight: 6.2 lbs./2.8 kg.
WLL: 5,500 lbs./2,500 kg.



49706-10
Standard
Wilson Track Slider
Weight: 12.5 lbs./5.7 kg.
WLL: 5,500 lbs./2,500 kg.



49706-11
Low Profile
Wilson Track Slider
Weight: 11.5 lbs./5.2 kg.
WLL: 5,500 lbs./2,500 kg.



49246-10-BP
Standard
Utility Trailer Track Slider
Weight: 13 lbs./5.9 kg.
WLL: 5,500 lbs./2,500 kg.



PATENTED

RATCHETING WINCHES

Faster and more convenient than traditional winches. Reduces the tensioning time by 33%. Also, reduces risk of winch bar rollover. Once the winch bar tip is inserted into the winch cap, the winch can be fully tensioned without the need to repetitively remove and reposition the winch bar.

LOOSE TIE DOWNS?

Even with enough tie downs in place, if any are loose or defective, you could get a citation.

WEB WINCHES

3-Bar

Weld-on and 3-Bar winches are available in various finishes, including X-Treme Zinc.



48101-103
3-Bar Weld-on
Side Mount
Weight: 9.5 lbs./4.3 kg.
WLL: 6,000 lbs./2,730 kg.



48101-103-XZ
3-Bar Weld-on
Side Mount
X-Treme Zinc Finish
Weight: 9.5 lbs./4.3 kg.
WLL: 6,000 lbs./2,730 kg.

DID YOU KNOW?
Portable and slider winches are engineered to be placed anywhere along side the trailer as needed to best secure the load.



48101-133
3-Bar Low Profile Weld-on
Bottom Mount
Weight: 9.6 lbs./4.4 kg.
WLL: 6,000 lbs./2,730 kg.



48101-143
3-Bar Standard Weld-on
Bottom Mount
Weight: 11.3 lbs./5.1 kg.
WLL: 6,000 lbs./2,730 kg.



48101-163-XZ
3-Bar Standard Portable
w/ 2 Set Screws
X-Treme Zinc Finish
Weight: 11.2 lbs./5.1 kg.
WLL: 6,000 lbs./2,730 kg.



48101-173
3-Bar Standard
C Track Slider
Weight: 10.4 lbs./4.7 kg.
WLL: 6,000 lbs./2,730 kg.



49207-273
3-Bar Standard
Double L Track Slider
Weight: 8.7 lbs./3.9 kg.
WLL: 5,500 lbs./2,500 kg.



49207-273-XZ
3-Bar Standard
Double L Track Slider
X-Treme Zinc Finish
Weight: 8.7 lbs./3.9 kg.
WLL: 5,500 lbs./2,500 kg.

49207-283-XZ
3-Bar Low Profile
Double L Track Slider
X-Treme Zinc Finish
Weight: 9.2 lbs./4.2 kg.
WLL: 5,500 lbs./2,500 kg.



Introducing Ancra's new bolt-on side mount 3-Bar winch. All Ancra 3-bar winches comply with FMCSA, WSTDA-T3 and Canadian Standard 905 regulations.

49997-113 NEW
3-Bar Side Mount Bolt-on
Lighter 7mm heat treated frame
Weight: 9.8 lbs./4.4 kg.
WLL: 5500 lbs./2500 kgs



COMBINATION WEB/CABLE WINCHES

Ancra Combination Winches are made in a variety of configurations to fit applications that require cable or webbing tie downs.



41681-10
Standard Bottom Mount
Weight: 10.6 lbs./4.8 kg.
WLL: 5,500 lbs./2,500 kg.



43488-20
Low Profile Side Mount
Weight: 10.9 lbs./4.9 kg.
WLL: 5,500 lbs./2,500 kg.



43908-10
Recessed Box
Weight: 12.9 lbs./5.9 kg.
WLL: 5,500 lbs./2,500 kg.



43997-10
Low Profile Leg Bracket
Weight: 8.7 lbs./3.9 kg.
WLL: 5,500 lbs./2,500 kg.

CABLE WINCH

For cable applications, Ancra offers these popular models. Your cable selection must be consistent with your cable manufacturer's safe working load ratings.



END MOUNT

41696-10
End Mount RH
Weight: 15.4 lbs./7.0 kg.
WLL: 5,500 lbs./2,500 kg.

41696-11
End Mount LH
Weight: 15.4 lbs./7.0 kg.
WLL: 5,500 lbs./2,500 kg.



'TRUCKER TIP'

CARGO THAT IS NOT BLOCKED MUST HAVE AT LEAST 2 TIE DOWNS IN THE FIRST 10 FEET AND ONE ADDITIONAL TIE DOWN FOR EACH ADDITIONAL 10 FEET OR FRACTION THEREOF. FOR COMPLETE INFORMATION, REFER TO THE FMCSA AND OR CANADIAN REGULATIONS.

LASHING WINCHES

The lashing winch with double hex drive can be bolted or welded to the trailer like a standard winch, yet offers the quick release and easy operation of a ratchet buckle.



47640-31

With double hex drive and three mounting holes.
Weight: 3.8 lbs./1.7 kg.
WLL: 3,333 lbs./1,515 kg.

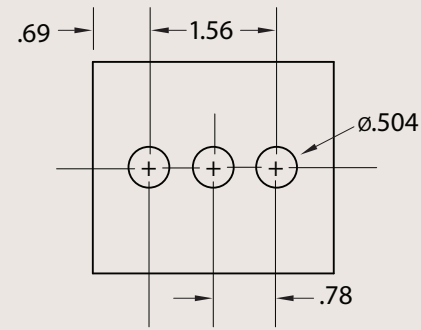

48496-11

With double hex drive, release latch, and single mounting hole.
Weight: 2.2 lbs./1 kg.
WLL: 2,500 lbs./1,135 kg.

WINCH MAINTENANCE

Though winches don't actually come in contact with the load, their function of tightening and anchoring the webbing or cable is critical to the security of over-the-road cargo hauling.

INSPECTION

To insure winches will perform, a quick inspection before each use will assure they are undamaged and working properly. Damaged or non-operational winches should be replaced immediately.

CARE

For optimum performance, winches should be cleaned to remove dirt, mud, road salt, and ice. Lubrication ensures that gravity will allow the winch pawl to drop freely into the sprocket teeth, and the sprocket will rotate freely. When not in use, portable winches should be cleaned and stored in a dry location. With a little care, your winches will go a long way.

PORTAWINCH® AND PORTANCHOR®

PATENTED

Turn stake pockets into strap anchor points.

Ankra has created a way you can turn standard stake pockets into solid anchor points for securement straps. Our FMCSA compliant 3-Bar PortaWinch and PortaAnchor offer a versatile system that allows you to position the tie down straps anywhere along either side, front or back of the trailer, using stake pockets that best accommodate your load.

- ▶ Fasten straps securely and in compliance with federal regulations.
- ▶ Working Load Limit (WLL) 5,500 lbs./ 2,495 kg.
- ▶ For use with standard winch straps and tensions with standard winch bar.
- ▶ Fits all standard stake pockets. Will not fit tapered stake pockets.
- ▶ Installs easily without tools.
- ▶ Works over tires and toolboxes.
- ▶ Removable when not in use.



Installs easily with patented spring-loaded front hook design that distributes the load evenly across the stake pocket. Cap has four holes and accommodates standard winch bars.

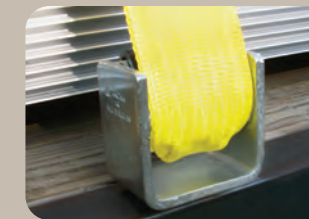

PortaAnchor accepts straps with flat hooks and straps with chain anchors.

PORTAWINCH® PATENTED

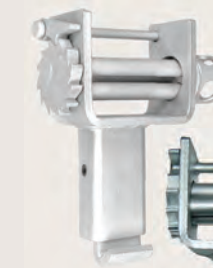

49716-10

Standard outward off-set.
Weight: 11.5 lbs./5.2 kg. WLL: 5,500 lbs.

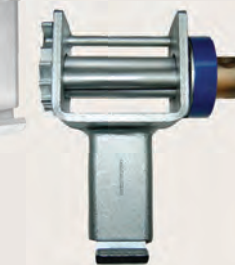

49716-10-RW

Ratcheting PortaWinch
Standard outward off-set.
Weight: 13.2 lbs./5.9 kg. WLL: 5,500 lbs.

49716-11

Inward off-set to allow for track-mounted tarp clearance.
Weight: 11.5 lbs./5.2 kg. WLL: 5,500 lbs.

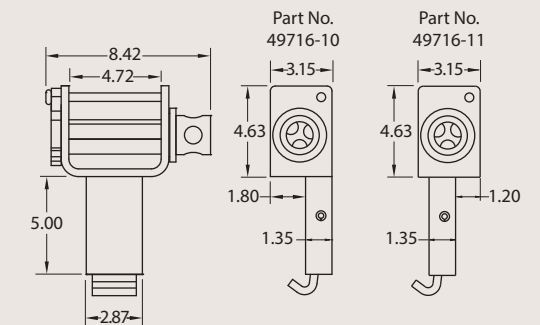

PORTANCHOR® PATENTED



49717-10

Standard outward off-set.
Weight: 9.5 lbs./4.3 kg.
WLL: 5,500 lbs.

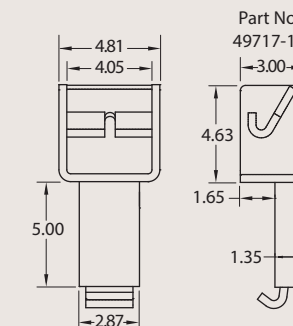

Flat Hook Application



Chain Anchor Application

WINCH DIMENSIONS (inches)

Ankra Part No.	A Overall Width	B Inside Frame Width	C Frame Height	D Frame Depth	Ankra Part No.	A Overall Width	B Inside Frame Width	C Frame Height	D Frame Depth
41681-10	9.75	6.8	5.4	3.5	48101-103	8.6	4.8	4.3	4.0
41691-10	7.6	4.8	5.0	3.9	48101-103-XZ	8.6	4.8	4.3	4.0
41696-10	7.1	4.2	10.0	3.9	48101-133	8.6	4.8	4.3	4.0
41696-11	7.1	4.2	10.0	3.9	48101-143	8.6	4.8	5.5	4.0
43488-20	9.4	6.5	4.1	4.0	48101-163-XZ	8.6	4.8	6.5	4.0
43563-10	7.6	4.6	5.4	3.5	48101-173	8.5	4.8	6.1	4.0
43563-10-RW	8.6	4.6	6.6	4.0	48496-11	4.4	2.1	2.5	4.9
43564-12	7.6	4.6	6.2	3.5	48783-10	9.2	4.6	5.4	3.5
43564-147	7.3	4.6	5.5	3.5	49207-127	7.5	4.6	6.6	4.0
43564-147-RW	8.0	4.6	5.5	3.5	49207-127-RW	8.0	4.6	6.5	4.0
43564-16	7.6	4.7	4.1	4.0	49207-127-XZ	7.5	4.6	6.6	4.0
43565-127	7.6	4.6	7.5	4.0	49207-137	7.5	4.6	6.0	4.0
43565-127-RW	10.0	4.6	7.5	4.0	49207-137-RW	8.0	4.6	6.0	4.0
43565-127-XZ	7.6	4.6	7.5	4.0	49207-137-XZ	7.5	4.6	6.0	4.0
43565-137	9.2	4.6	6.5	4.0	49207-187	7.5	4.6	5.3	4.0
43565-147	7.6	4.2	7.5	4.0	49207-187-RW	8.0	4.6	5.3	4.0
43565-157	7.6	4.6	6.5	4.0	49207-187-XZ	7.3	4.6	5.3	4.0
43565-157-RW	8.0	4.6	6.5	4.0	49207-273	8.6	4.9	5.7	4.0
43565-157-XZ	7.6	4.6	6.5	4.0	49207-273-XZ	8.6	4.9	5.7	4.0
43573-10	7.6	4.6	6.2	3.5	49207-283-XZ	8.6	4.9	4.7	4.0
43579-20	7.4	4.8	4.1	4.0	49246-10-BP	7.6	4.6	6.5	3.5
43908-10	10.3	9.5	5.5	4.0	49706-10	7.9	4.9	6.5	4.0
43997-10	10.3	7.2	5.0	3.9	49706-11	7.9	4.9	5.1	4.0
47640-31	5.9	2.1	4.0	3.0					

Winch dimensions are subject to change.

Winches are labeled with installation, maintenance and proper use instructions.

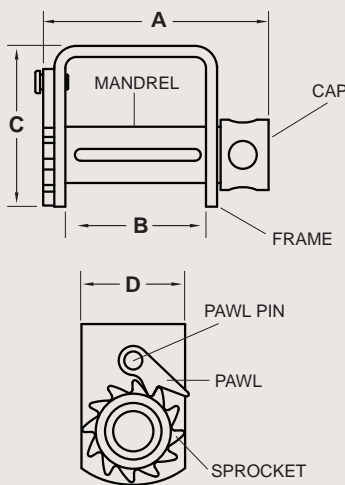

WARNING
FAILURE TO COMPLY WITH THESE INSTRUCTIONS MAY RESULT IN INJURY OR DEATH AND/OR LOSS OF LOAD.

INSTALLATION
GENERAL: This winch is designed for use on a flatbed trailer. It is not to be used on a vehicle or other equipment. The winch must be installed on a flatbed trailer that is rated for the weight of the winch and the load. The winch must be installed on a flatbed trailer that is rated for the weight of the winch and the load. The winch must be installed on a flatbed trailer that is rated for the weight of the winch and the load.

OPERATION AND MAINTENANCE
GENERAL: This winch is designed for use on a flatbed trailer. It is not to be used on a vehicle or other equipment. The winch must be installed on a flatbed trailer that is rated for the weight of the winch and the load. The winch must be installed on a flatbed trailer that is rated for the weight of the winch and the load. The winch must be installed on a flatbed trailer that is rated for the weight of the winch and the load.

CAUTION
TO AVOID PERSONAL INJURY WHILE TENSIONING AND RELAXING WINCH ASSEMBLY, MAKE SURE LATCH PAWL IS FULLY ENGAGED INTO SPROCKET TEETH BEFORE RELAXING PRESSURE ON WINCH BAR.

ANCRACARGO

AVERTISSEMENT
LE NON RESPECT DE CES INSTRUCTIONS PEUT ENTRAINER DES BLESSURES OU LA MORT ET/OU UNE PERTE DE CHARGEMENT.

INSTALLATION
GENERAL: This winch is designed for use on a flatbed trailer. It is not to be used on a vehicle or other equipment. The winch must be installed on a flatbed trailer that is rated for the weight of the winch and the load. The winch must be installed on a flatbed trailer that is rated for the weight of the winch and the load. The winch must be installed on a flatbed trailer that is rated for the weight of the winch and the load.

OPERATION ET MAINTENANCE
GENERAL: This winch is designed for use on a flatbed trailer. It is not to be used on a vehicle or other equipment. The winch must be installed on a flatbed trailer that is rated for the weight of the winch and the load. The winch must be installed on a flatbed trailer that is rated for the weight of the winch and the load. The winch must be installed on a flatbed trailer that is rated for the weight of the winch and the load.

ATTENTION
POUR EVITER LES BLESSURES PERSONNELLES PENDANT LE TENSIONNAGE ET LE RELAXAGE DE L'ENSEMBLE DE TRAVAIL, ASSUREZ-VOUS QUE LE CLAUSET DE VERROUILLAGE EST BIEN ENGAGE DANS LES DENTS DE LA ROUE AVANT DE RELACHER LA TENSION SUR LA BARRE DE TRAVAIL.

PREPARACION
PARA EVITAR LES LESIONES PERSONALES MIENTRAS SE TENSIONA Y SE RELAXA EL CONJUNTO DE TRABAJO, ASEGURESE DE QUE EL TORNILLO DEL PERILLO ESTE DEBIDAMENTE ENGANCHADO EN LOS DIENTES DEL ENGRANAJE ANTES DE RELAXAR LA TENSION EN LA BARRA DE TRABAJO.

ADVERTENCIA
NO SEGUIR ESTAS INSTRUCCIONES PUEDE RESULTAR EN LESIONES, MUERTE O PERDIDA DE LA CARGA.

INSTALACION
GENERAL: Este winch está diseñado para usarse en un remolque plano. No se debe usar en un vehículo u otro equipo. El winch debe instalarse en un remolque plano que esté clasificado para el peso del winch y la carga. El winch debe instalarse en un remolque plano que esté clasificado para el peso del winch y la carga. El winch debe instalarse en un remolque plano que esté clasificado para el peso del winch y la carga.

OPERACION Y USO
GENERAL: Este winch está diseñado para usarse en un remolque plano. No se debe usar en un vehículo u otro equipo. El winch debe instalarse en un remolque plano que esté clasificado para el peso del winch y la carga. El winch debe instalarse en un remolque plano que esté clasificado para el peso del winch y la carga. El winch debe instalarse en un remolque plano que esté clasificado para el peso del winch y la carga.

PRECAUCION
PARA EVITAR LESIONES PERSONALES AL TENSIONAR Y RELAXAR EL CONJUNTO DE TRABAJO, ASEGURESE DE QUE EL TORNILLO DEL PERILLO ESTE DEBIDAMENTE ENGANCHADO EN LOS DIENTES DEL ENGRANAJE ANTES DE RELAXAR LA TENSION EN LA BARRA DE TRABAJO.

WINCH TRACK

Ankra winch track comes in two distinct styles:

- Standard C track, designed for use with the 43565 series C track slider winches, is available in roll-formed ¼" plate steel (42357-11), or aluminum (42357-21) for aluminum trailers.
- Double L aluminum track, designed for use with 49207 series slider winches, is available in standard depth (49242-10-120) and low profile (49789-10-120).

Custom lengths are available upon request. Winch track should be installed to meet the testing requirements of TTMA RP No. 47-03.

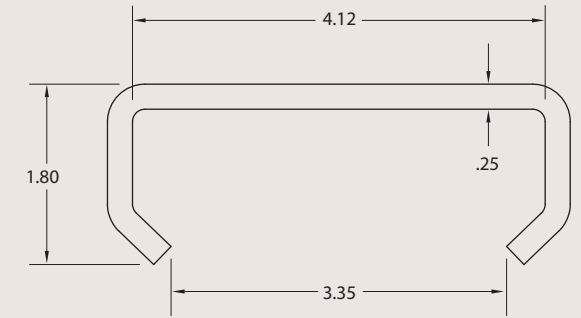
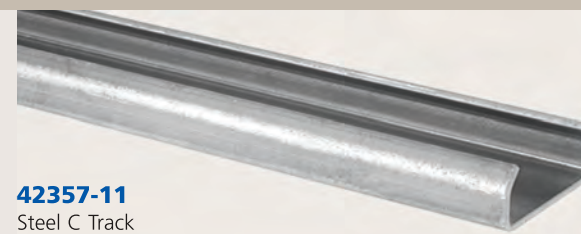

42357-11
Steel C Track
Weight: 39.0 lbs./17.73 kg. Length: 6'

42357-12
Steel C Track
Weight: 78.0 lbs./35.4 kg. Length: 12'



42357-21
Aluminum C Track
Weight: 19.0 lbs./8.64 kg. Length: 6'

49242-10-120
Aluminum Double L Track
Weight: 20.9 lbs./9.5 kg. Length: 10'

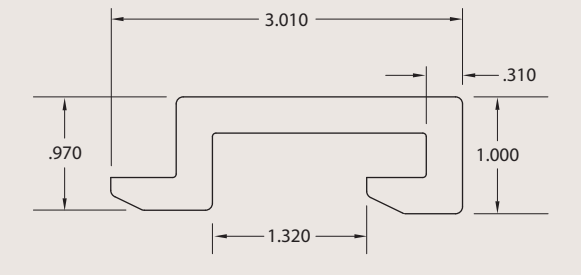
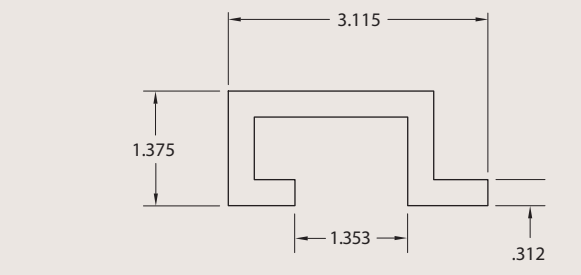
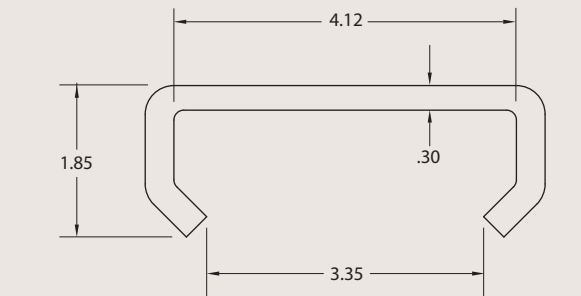

49789-10-120.00
Low Profile Aluminum Double L Track
Weight: 16.83 lbs./7.64 kg. Length: 10'

SILVERCAP OVERDRIVE® RATCHETING CAP PATENTED

Convert any winch into a ratcheting winch by adding Ancra's OverDrive Ratcheting Cap. The OverDrive Ratcheting Cap has been re-engineered to feature the enhanced ratcheting mechanism employed by all Ancra Ratcheting Winches. Benefits of the OverDrive Ratcheting Cap include an easy access grease fitting for maintaining effortless function and ease of installation onto standard winches using the hardware provided. The patented design includes internal seals to keep out moisture and road grime so an outer rubber sleeve is no longer needed. Your winch bar stays in the winch until your straps are tight.

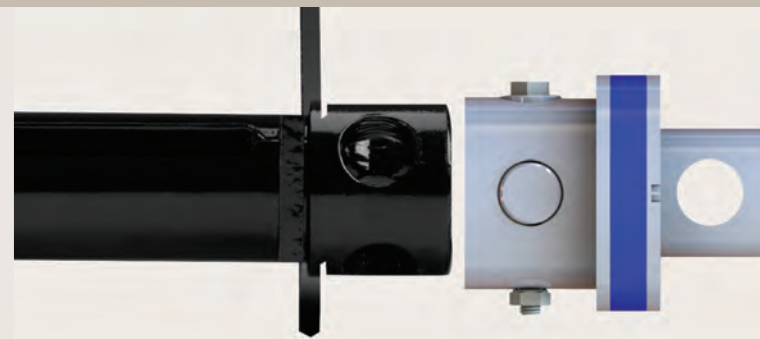

**SilverCap
OverDrive®**



49723-10
Weight: 3.45 lbs./1.56 kg.

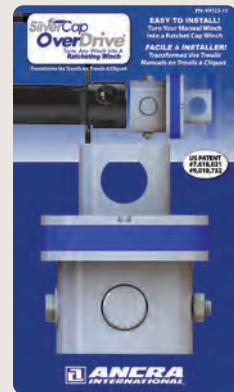

Ancra's OverDrive® is the easy upgrade for winches. With a ratcheting winch, you work faster because the winch bar stays in the winch until the strap is tight.

To install on any winch:

1. Simply slide the OverDrive unit over the cap of the existing winch.
2. Rotate cap to line up holes and insert pin.
3. Secure it with the bolt.

It's that simple. All necessary parts are included.

Assembly Diagram Schéma de Montage

Lubrication: Periodically add lubricant through grease fitting to maintain ratchet function. Use needle adapter on grease gun. Shell Gadus S2 V100 is recommended. **DO NOT OVERFILL.**

Lubrification : Ajouter périodiquement du lubrifiant graisseur pour maintenir la fonction de cliquet. Utilisez un adaptateur d'aiguille sur le pistolet graisseur. Shell Gadus S2 V100 est recommandé. **NE PAS TROP REMPLIR.**

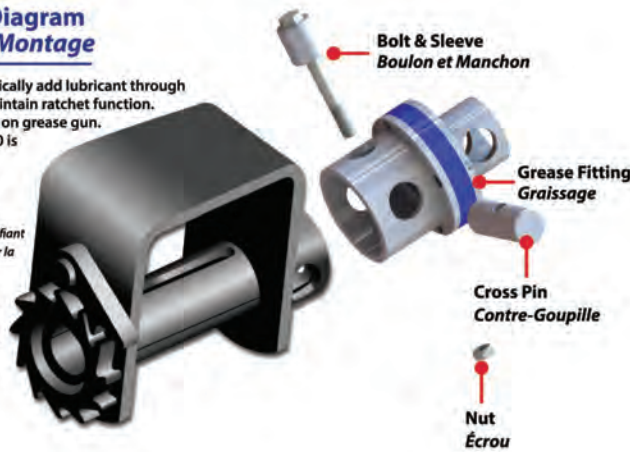

FLATBED ACCESSORIES PATENTED

ERGO 360° Winch Bars



FIRST ANGRA RAISED THE BAR. THEN WE BENT IT.

ErgoBar®
A NEW ANGLE
ON THE WINCH BAR®

See what a difference a bend in the bar makes.

The Ergo 360° Bar takes Ancra's winch bars to the next level. The patented ergonomic design maintains parallel alignment of handle and tip, so you can rotate the bar for optimum leverage without removing it, and keep it secured in the winch cap through the mushroom tip. Easy to carry, easy to handle, the Ergo 360° Bar is the most efficient and economical new tool you'll use. Available in standard, combination and combination box end models. Combination winch bars can be used to release tension on chain binders. Use caution to avoid injury. Not to be used as a cheater bar.



50015-10
Standard Painted.
Weight: 5.0 lbs./2.27 kg.

50015-20
Combination Painted.
Weight: 6.5 lbs./2.95 kg.

50015-21
Combination Box End Painted.
Weight: 6.0 lbs./2.72 kg.

FLATBED ACCESSORIES

Standard Winch Bars

Tapered and angled at the end for easy operation, Ankra's winch bar handles are knurled at two sections, and the mushroom tip helps keep the bar from slipping from the winch cap. They are heat-treated for extra strength and cycle tested to simulate years of heavy use. Combination winch bars can be used to release tension on chain binders. Use caution to avoid injury. Not to be used as a cheater bar.

Flanged mushroom tip helps keep the bar from slipping from the winch cap.



42313-10
Standard Painted. Weight: 5.0 lbs./2.27 kg.



42313-17
Standard Chrome. Weight: 5.0 lbs./2.27 kg.



42313-19
Combination Chrome. Weight: 6.5 lbs./2.95 kg.



42313-12
Combination Box End Painted Silver and Yellow. Weight: 6.5 lbs./2.95 kg.

Heavy Duty D-Rings



Rugged forged steel D-Rings add versatility for securing complex loads. Utility trailers typically use 1/2 and 5/8 inch models, while heavy-duty applications rely on the 3/4 and 1-inch sizes. Individually polybagged.

49896-10 1/2" Forged steel w/ Bolt-on clip Wt: 1.0 lbs./0.50 kg. WLL: 4,000 lbs.	49896-11 1/2" Forged steel w/ Weld-on clip Wt: 1.0 lbs./0.50 kg. WLL: 4,000 lbs.	49897-10 5/8" Forged steel w/ Weld-on clip Wt: 1.9 lbs./0.86 kg. WLL: 6,300 lbs.	49898-10 3/4" Forged steel w/ Weld-on clip Wt: 2.2 lbs./1.0 kg. WLL: 9,000 lbs.	49899-10 1" Forged steel w/ Weld-on clip Wt: 4.4 lbs./2.0 kg. WLL: 15,600 lbs.	49899-11 NEW 1" Forged Bent D-Ring Assembly w/ Weld-on clip. Wt: 4.8 lbs./2.1 kg. WLL: 15,600 lbs.
--	--	--	---	--	--

FLATBED ACCESSORIES

Hooks & Web Winders

44102-11

H-2 Hook. Flame-cut from 5/8-in. material and can be welded on vehicles. Accepts web loops, D-Rings, cable or rope. Meets anchorage requirements when properly secured. Hook opening .81" Weight: .61 lb./ .28 kg. WLL: 5,400 lbs./2,450 kg.

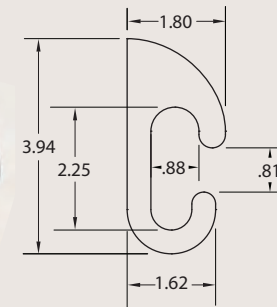

44122-10

Corner Iron Hook
Constructed with no sharp corners to reduce abrasion to rope or cable.
Weight: .63 lb./0.29 kg.



50024-10

Tarp Hook. For securing tarp straps to trailers.
1/2-in. steel wire.
Unfinished light oil.
Weight: .39 lb./0.18 kg.

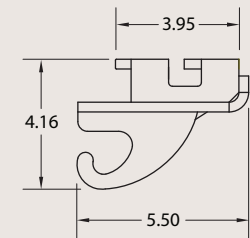

49768-10

Double L Track Slider Hook
Black powder coat finish.
Hook opening .71"
Weight: 5.65 lbs./2.57 kg.
WLL: 5,500 lbs./2,500 kg.



50092-10

EZ Winder Strap Winder quickly and easily winds webbing onto your winch for storage.
Weight: 1.1 lbs./0.5 kg.

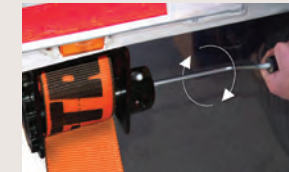

45801-10

Web Winder. Constructed of all steel, the Ankra Web Winder winds 2-in., 3-in. and 4 in. winch straps for compact storage. Easy to attach to vehicle rails, easy to remove with tapered forks, and easy to disassemble for storage.
Weight: 3.25 lbs./1.48 kg.

50391-10

Premium Cargo Strap Winder
Constructed of zinc-plated steel for maximum durability, the new Strap Winder quickly assists in winding winch straps into rolls for storage. Designed to clip into trailer stake pocket or side rail.
Weight: 2.7 lbs./1.2 kg.



Heavy Duty Strap Storage Band

Keep stored straps from unrolling with our 1-inch by 7-inch long storage bands. Made of natural rubber, the storage bands are tough and easy-to-use at low temperatures.

NEW **50433-10** Pack of 5

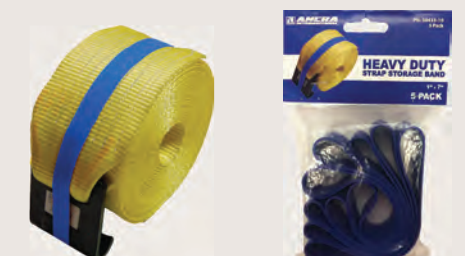

FLATBED ACCESSORIES

GlideLock® Double L Track Flat Hook Sliding Bracket

Lock and load with GlideLock® movable securement bracket for double L track

GlideLock Sliding Load-Securement Bracket offers versatility and positioning of tie down anchor point.

Once the flat hook is engaged, the unit locks the hook in position. It cannot shift or come undone, it remains secure until you unlock it. Meets Federal Motor Safety Administration (FMCSA) standards.

Provides a sliding positive attachment point for flat hooks in double L track.



49527-10
GlideLock for Double L Track
WLL: 5,400 lbs./2,450 kg.
Weight 4.50 lbs./2.04 kg



How GlideLock Works

With a Working Load Limit of 5,400 lbs., GlideLock glides into any position along the trailer rail or winchtrack to ensure the correct pull-angle for securing cargo. The compact unit keeps the strap inboard of the rail and works with any standard flat-hook strap.

Coil Racks

Our coil racks are designed to aid in supporting steel coils on flatbed trailers. Available for both light and heavy duty applications. Used with lumber blocks which provide extra cradling of the coils. Both have a black lacquer finish. New D.O.T. standards specifically address securement of metal coils. When chocks are used, they must be held in place by coil bunks or racks to prevent them from coming loose.

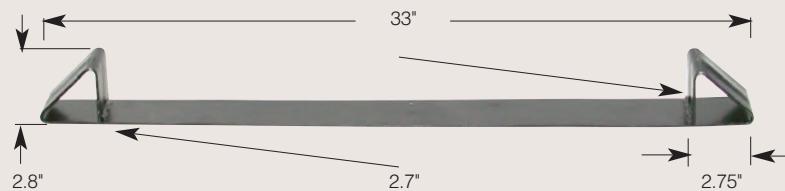
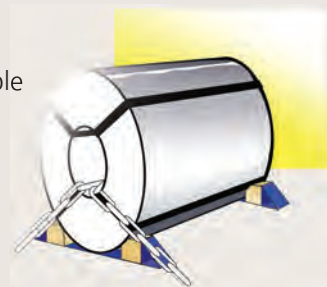

49344-10
Standard Duty
Metal Gauge: 10
Weight: 5.7 lbs./2.60 kg.

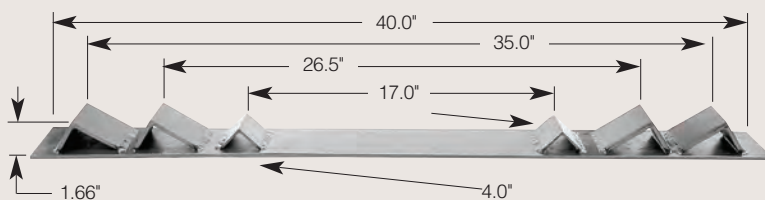

49344-12
Heavy-Duty 1/4" steel sheet per ASTM A36
Weight: 16.75 lbs./7.6 kg.

FLATBED ACCESSORIES

Corner Protectors

Along with our standard rugged flatbed products, Ancra accessories offer high performance and durability. Sturdy corner and web protectors prevent abrasion of cargo and cargo-securing straps. **Corner Protectors not to be used as sling protection for overhead lifting.**



43986-10
High Density Polymer
Suitable for webbing up to 4".
5.25" wide and extends approx.
3.5" to protect the load. **Has excellent low temperature performance, down to -20°F.**
Weight: .06 lb./0.03 kg.

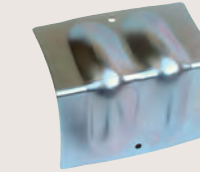

49377-10
Steel (Zinc Plated)
For use with chain and extends
4" to protect the load.
Weight: 1.10 lbs./50 kg.

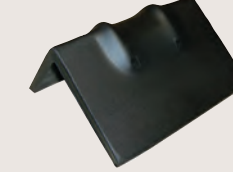

49377-11
Rubber coated Steel
For use with chain and extends
4" to protect load.
Weight: 1.9 lbs./86 kg.



49577-10
Steel (Galvanized)
For use with chain. 4" wide
and extends 3" on top and
3.5" to protect the load.
Weight: .90 lb./41 kg.

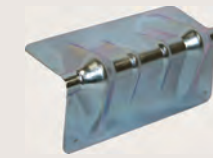

49756-10
Steel Corner Protector for chain and up to
4" winch straps and extends 3-5/8" to
protect the load. Weight: 1.26 lbs./57 kg.



41516-11
Aluminum 6061-T6
Suitable for 2" webbing.
Weight: .63 lbs./29 kg.



49584-10
12" Long Plastic. Extends approx. 3" to protect
the load. Suitable for webbing up to 4" in width.
**Has excellent low temperature performance,
down to -20°F.** Weight: .47 lb./21 kg.



42098-11
Fiber Reinforced Rubber. Extends approx
5" to protect the load for webbing up to
3" in width. Weight: .63 lb./29 kg.

42098-12

Extends approx 5" to protect the load for webbing up to 4" in width.
Weight: .75 lb./34 kg.



49913-10
Tarp Protector. Yellow plastic.
Weight: .21 lb./9 kg.

Web Protector



40985-05-12
12-in. Cordura® Nylon sleeve for 2-in.
webbing. Weight: .13 lb./0.06 kg.

40985-05-RL
100-yd. bulk roll Cordura Nylon sleeve
for 2-in. webbing. Weight: .39 lb./yd./
.18 kg./meter. Cordura® is a registered
trademark of Dupont.

FMCSA Cargo Securement Standard, Section 393.104 (f)(4)

Edge protection must be used whenever a tiedown would be subject to abrasion or cutting at the point where it touches an article of cargo. The edge protection must resist abrasion, cutting and crushing.

FLATBED ACCESSORIES

X-TREME GUARD® PROTECTS YOUR LOAD AND YOUR STRAPS

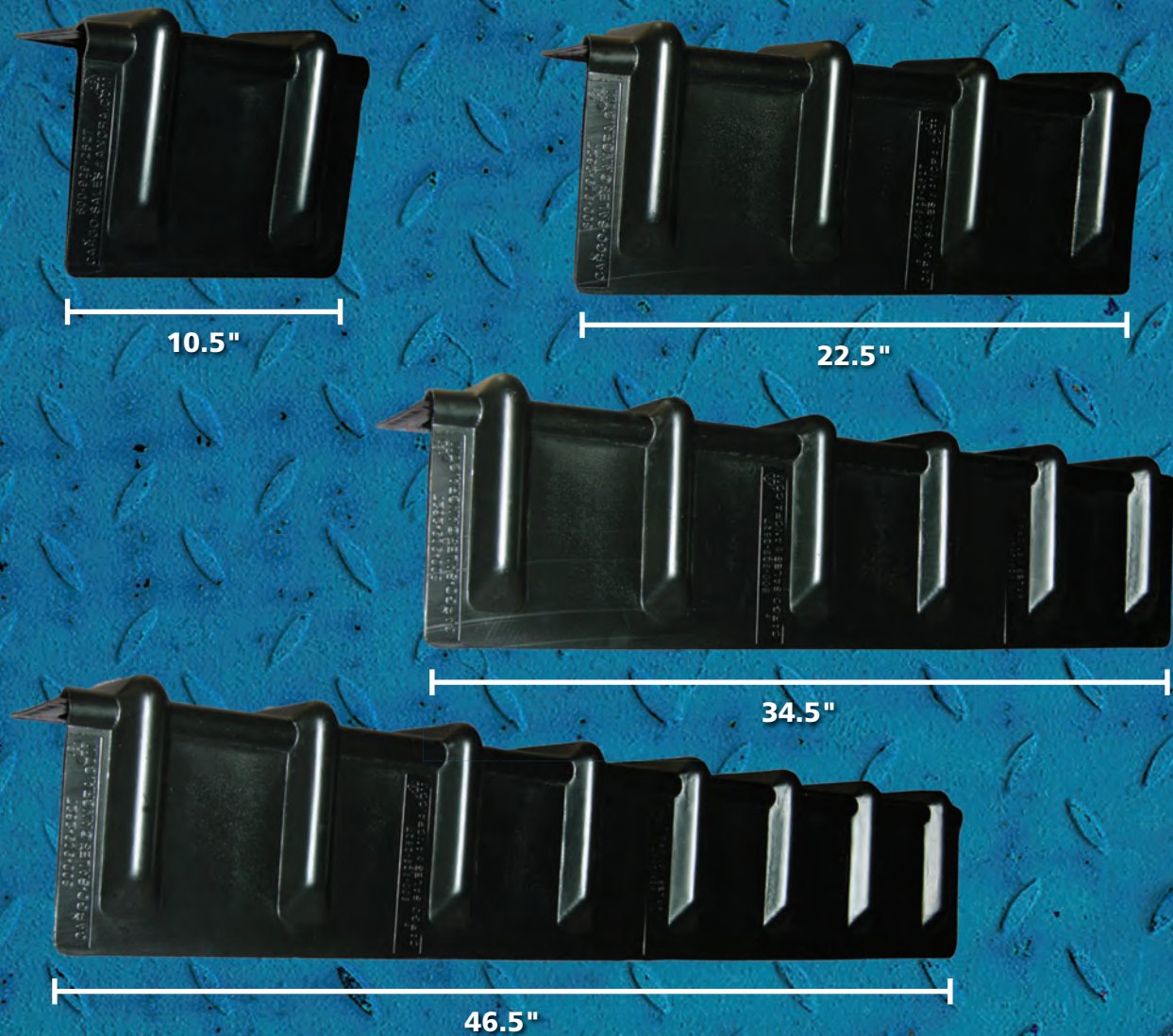

Ancra's new high-density polyethylene X-TREME GUARD™ Corner Protector distributes strap tension over the length of the guard to prevent your cargo from being crushed by the straps and protects your webbing from abrasion. Made in lengths of 10.5-, 22.5-, 34.5- and 46.5-inches, this durable guard is strong yet lightweight, and crack/weather resistant to -30°. **Corner Protectors not to be used as sling protection for overhead lifting.**



- 50089-12** 8" x 1' (10.5") long — Wt: .8 lb./ .36 kg.
- 50089-24** 8" x 2' (22.5") long — Wt: 1.7 lbs./ .78 kg.
- 50089-36** 8" x 3' (34.5") long — Wt: 2.7 lbs./ 1.23 kg.
- 50089-48** 8" x 4' (46.5") long — Wt: 3.6 lbs./ 1.63 kg.

Made in the USA

FLATBED ACCESSORIES

Flatbed Trailer Ladder

NEW 5-Step Convenience. Designed for use on standard, aluminum and hybrid trailers, Ancra's portable, durable 5-Step Ladder gives you a quick and easy lift onto your vehicle. Measuring 20" wide and 89" tall with handles extended and 5' with handles inverted, the easy-to-store ladder hangs securely on the trailer's rub rail with no need for permanent installation or additional parts.

- ▶ Available in white powder coated aluminum
- ▶ Maximum user weight: 400 lbs.
- ▶ High performance anti-slip treads and rubber feet
- ▶ 17.5" tread width with 12" spacing between treads



50490-10
5-Step White Powder Coated Aluminum Ladder
Weight: 10.1 lbs./4.58 kg.



NEW 50557-10 Storage Bracket Kit for Flatbed Trailer Ladder

Kit has a base assembly and an upper bracket with lockable closure to secure one Ancra Flat Bed Access Ladder. The base assembly supports the legs of the ladder and the upper bracket has a rotating, lockable arm that secures the top rung and upper section of the ladder in place. The set is designed to be mounted to the backside of the tractor cab to make sure the ladder is always available to the driver no matter what trailer is being hauled.

BENEFITS:

- ▶ Provides a convenient and secure storage for the Ancra Flat Bed Trailer Access Ladder
- ▶ The lockable rotating arm on the upper bracket has a detent function to hold the arm up in position 90 degrees in either direction to hold it out of the way to make it easier to install the ladder rung into the bracket cradle
- ▶ The phosphate primer with black powder coat provides two layers of corrosion resistance



Base Assembly

Upper Bracket



Storage Bracket Kit with Ladder in Place and Padlocked



50491-10 Van Trailer Bracket Kit
Mounts under the rear door of van trailers to allow use of the flatbed ladder.

Corner Protector Placement Tool

Now there's no need to climb onto the load to position a corner protector on the top corners of your flatbed trailer cargo. Stand firmly on the ground with Ancra's Corner Protector Placement Tool, a lightweight, telescoping tool with powder-coated steel handle and impact-resistant durable head that has a recessed center that repositions cargo straps over the load. The Placement Tool works with the X-Treme Guard corner protectors as well as most other Ancra corner protectors, including: 43986-10, 49377-10, 49377-11, 49756-10 and 49584-10.

NEW 50451-11 Corner Protector Placement Tool

Extension Pole: 4ft.– 8ft. Weight: 4.2 lbs./ .57 kg.



FLATBED ACCESSORIES

Top Premium Brand Tarp Ties



In the heavy duty trucking industry, Goldline® Heavy Duty EPDM Tarp Ties have been a favorite with fleets and independent owners for 45 years.

Made in the USA and known for quality, durability, and resistance to the elements, these tarp ties offer good stretch recovery and maintain their strength over the entire life of the tarp ties. The two lines include the longest lasting, larger cross section Goldline® Heavy Duty EPDM tarp ties best recognized by truckers, and the standard cross section Silverline Elite® EPDM. Our natural rubber tarp ties

are best suited for colder climates and are our most economical offering. Ancra's tarp tie offering provides you the customer with product options that can be chosen and suited to your application.

- ▶ Quantity 50 per box
- ▶ Designed to hold tarp covers on trucks and trailers
- ▶ Not to be used to restrain or secure cargo
- ▶ Molded EPDM construction for high Ozone resistance and strength resiliency or molded natural rubber for good cold weather stretch properties
- ▶ Wear safety glasses and use caution when using tarp ties
- ▶ WARNING: SUDDEN RUPTURE OR DISCONNECT WHILE IN STRETCHED POSITION CAN CAUSE SERIOUS INJURY



- 52210GL**
Goldline HD EPDM made in the USA-10"
- 52215GL**
Goldline HD EPDM made in the USA-15"
- 52221GL**
Goldline HD EPDM made in the USA-21"
- 52231GL**
Goldline HD EPDM made in the USA-31"
- 52241GL**
Goldline HD EPDM made in the USA-41"



- 52210SE**
Silverline Elite EPDM made in the USA-10"
- 52215SE**
Silverline Elite EPDM made in the USA-15"
- 52221SE**
Silverline Elite EPDM made in the USA-21"
- 52231SE**
Silverline Elite EPDM made in the USA-31"
- 52241SE**
Silverline Elite EPDM made in the USA-41"

NATURAL RUBBER

- Crimped Ends**
- 52210C**
Natural Rubber Tarp Tie-10"
 - 52215C**
Natural Rubber Tarp Tie-15"
 - 52221C**
Natural Rubber Tarp Tie-21"
 - 52231C**
Natural Rubber Tarp Tie-31"
 - 52241C**
Natural Rubber Tarp Tie-41"

Rubber Rope & Hooks



- Standard 150-ft. coils
- Easily assembled to desired length for application.

- 49454-11**
3/8" Solid Core Rubber Rope
Weight: 7.4 lbs./3.35 kg.
- 49454-13**
7/16" Solid Core Rubber Rope
Weight: 10.7 lbs./4.86 kg.



- 49211-10**
Rubber Rope Hook
100 per pack
Weight: 5.2 lbs./2.37 kg.

- 41572-10**
Replacement Hooks for Tarp Ties
Bag of 100
Weight: 3.7 lbs./1.7 kg.

HOW TO ATTACH HOOK TO RUBBER ROPE

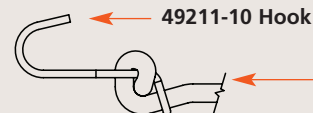
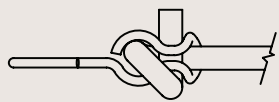

49454-11 Rubber Rope

GRADE 70 'TRANSPORT' CHAIN

Grade 70 chain was designed specifically to provide a light yet strong chain for tie downs. Made from heat treated carbon steel and zinc plated gold chromate for corrosion resistance. Chains are 100% proof tested to 2X WLL rating. Made to NACM standards per specifications of the FMCSA & CCMTA for tie down use. All clevis hooks are made of heat treated alloy steel.



BROWN BARREL
1/4-in. Chain



ORANGE BARREL
5/16-in. Chain



GREEN BARREL
3/8-in. Chain



RED BARREL
1/2-in. Chain

Grade 70 Chain Assemblies with Clevis Hooks



- 45881-10-16** 5/16-in. x 16-ft. WLL: 4,700 lbs./2,130 kg. Weight: 17.4 lbs./7.89 kg. 10 Assemblies per Orange Barrel
- 45881-10-20** 5/16-in. x 20-ft. WLL: 4,700 lbs./2,130 kg. Weight: 21.7 lbs./9.90 kg. 10 Assemblies per Orange Barrel
- 45881-10-25** 5/16-in. x 25-ft. WLL: 4,700 lbs./2,130 kg. Weight: 26.7 lbs./12.10 kg. 10 Assemblies per Orange Barrel
- 45881-11-16** 3/8-in x 16-ft. WLL: 6,600 lbs./2,990 kg. Weight: 24.4 lbs./11.08 kg. 10 Assemblies per Green Barrel
- 45881-11-20** 3/8-in. x 20-ft. WLL: 6,600 lbs./2,990 kg. Weight: 30.4 lbs./13.80 kg. 10 assemblies per Green Barrel
- 45881-11-25** 3/8-in. x 25-ft. WLL: 6,600 lbs./2,990 kg. Weight: 39.0 lbs./17.71 kg. 10 Assemblies per Green Barrel
- 45881-13-20** 1/2-in x 20-ft. WLL: 11,300 lbs./5,130 kg. Weight: 53.6 lbs./24.33 kg. 5 Assemblies per Red Barrel
- 45881-13-25** 1/2-in. x 25-ft. WLL: 11,300 lbs./5,130 kg. Weight: 66.2 lbs./30.05 kg. 5 Assemblies per Red Barrel

Grade 70 Bulk Chain



- 45880-12** 1/4-in. x 400-ft. WLL: 3,150 lbs./1,430 kg. Weight: 262 lbs./118.9 kg. Brown Barrel
- 45880-10** 5/16-in x 400-ft. WLL: 4,700 lbs./2,130 kg. Weight: 408 lbs./185 kg. Orange Barrel
- 45880-11** 3/8-in. x 200-ft. WLL: 6,600 lbs./2,990 kg. Weight: 296 lbs./134.4 kg. Green Barrel
- 45880-13** 1/2-in x 100-ft. WLL: 11,300 lbs./5,130 kg. Weight: 251 lbs./114 kg. Red Barrel

GRADE 70 'TRANSPORT' CHAIN

XHD™ 3/8" Chain Assemblies

The extreme heavy duty performance of G70 chain with the added strength and size of our G80 clevis hooks. Each part is heat treated and proof tested to twice the Working Load Limit. All chain assemblies are made to NACM standards and comply with the specifications of the FMCSA and CCMTA for tie down use.

- ▶ Available in 10' and 20' lengths
- ▶ G70 carbon steel, zinc plated, alloy chain with gold chromate finish
- ▶ G80 forged alloy hooks with 19% more material in the neck of the hook
- ▶ Individually packaged for resale inside color coded barrels

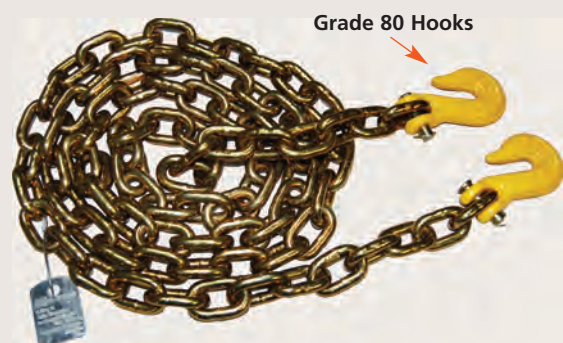

50364-38-10
Length: 10-ft./3.0m
WLL: 6,600 lbs./3,000 kg.
Weight: 17 lbs./7.7 kg.

50364-38-20
Length: 20-ft./6.0m
WLL: 6,600 lbs./3,000 kg.
Weight: 31 lbs./14.5 kg.

Packaged Transport Chain In A Pail

Packaged Grade 70 transport chain assemblies are offered in a convenient storage pail to keep organized in your tool box or vehicle. Grade 70 chain is specifically designed to provide a light, yet strong chain for tie downs. Made from carbon steel, heat treated for strength and zinc plated gold chromate for corrosion resistance. Made to NACM standards to meet the specifications of the FMCSA & CCMTA for tie down use. All clevis hooks are made of heat-treated alloy steel.



- 45881-10-16-SP** 5/16-in x 16-ft. WLL: 4,700 lbs./2,130 kg. Weight: 18.8 lbs./8.52 kg.
- 45881-10-20-SP** 5/16-in x 20-ft. WLL: 4,700 lbs./2,130 kg. Weight: 23.4 lbs./10.61 kg.
- 45881-10-25-SP** 5/16-in x 25-ft. WLL: 4,700 lbs./2,130 kg. Weight: 28.3 lbs./12.83 kg.
- 45881-11-16-SP** 3/8-in x 16-ft. WLL: 6,600 lbs./2,990 kg. Weight: 25.8 lbs./11.71 kg.
- 45881-11-20-SP** 3/8-in x 20-ft. WLL: 6,600 lbs./2,990 kg. Weight: 31.9 lbs./14.48 kg.
- 45881-11-25-SP** 3/8-in x 25-ft. WLL: 6,600 lbs./2,990 kg. Weight: 40.5 lbs./18.39 kg.

GRADE 70 CLEVIS HOOKS

Forged from high strength alloy steel, Anca clevis hooks are made for Grade 70 chain. Sized from 1/4" to 1/2", the chain hooks are heat treated for strength and durability. Each hook is marked with manufacturer ID and chain size and grade in compliance with the NACM Chain Hook Standard. Hooks are proof tested to twice their WLL rating and have 4:1 design factor to meet the NACM hook strength requirements.

Forged steel hook, zinc plated gold chromate finish. Individually polybagged with clevis pin and cotter pin included.

- 45946-12** 1/4-in. Clevis Hook WLL: 3,150 lbs./1,430 kg. Weight: .40 lbs./.18 kg.
- 45946-10** 5/16-in. Clevis Hook WLL: 4,700 lbs./2,130 kg. Weight: .85 lbs./.39 kg.
- 45946-11** 3/8-in. Clevis Hook WLL: 6,600 lbs./2,990 kg. Weight: 1.10 lbs./.5 kg.
- 45946-13** 1/2-in. Clevis Hook WLL: 11,300 lbs./5,130 kg. Weight: 2.10 lbs./1.04 kg.

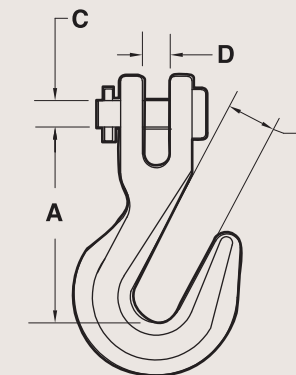

DIMENSION TABLE				
	A	B	C	D
45946-12	2.00	.40	.31	.36
45946-10	2.30	.43	.38	.38
45946-11	2.70	.50	.48	.44
45946-13	3.20	.66	.63	.75

Replacement G70 Clevis Pin

High strength steel replacement clevis pins are designed to meet the strength requirements of Grade 70 hooks and their heads are marked G7 or 70.

- NEW 50412-100** Packaged Kit Includes one zinc plated clevis pin and cotter pin for a 5/16 Grade 70 chain hook. Weight: .17 lb./0.07 kg.
- NEW 50412-102** Packaged Kit Includes one zinc plated clevis pin and cotter pin for a 3/8 Grade 70 chain hook. Weight: .22 lb./0.09 kg.
- NEW 50412-103** Packaged Kit Includes one zinc plated clevis pin and cotter pin for a 1/2 Grade 70 chain hook. Weight: .23 lb./0.10 kg.

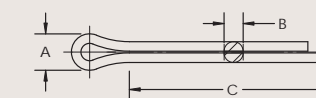
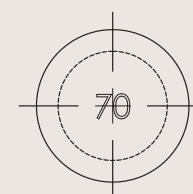

WARNING:

- DO NOT EXCEED RATED WORKING LOAD LIMIT (WLL) CAPACITY
- NOT TO BE USED FOR OVERHEAD LIFTING OR PULLING
- USE WITH LOAD BINDERS OF EQUAL OR HIGHER WLL RATINGS
- INSPECT BEFORE EACH USE. DO NOT USE IF CRACKED, BENT OR WORN.

CHAIN HARDWARE

We offer a wide selection of chain hardware for popular applications — from zinc plated clear chromate anchor shackles in screw pin and clevis pin models to Quick Links in various sizes. Corrosion resistant, zinc plated gold chromate Grade 70 Twin Clevis and Slip Hooks come in a wide range of sizes, with and without safety latches.

Screw Pin Anchor Shackle — Galvanized and individually polybagged

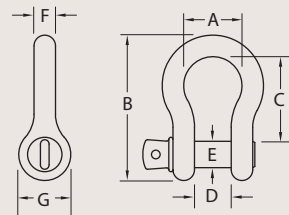

PART NUMBER	SIZE	WEIGHT	WLL
50013-31	5/16-in.	.18 lbs./08 kg.	1,500 lbs./681 kg.
50013-38	3/8-in.	.30 lbs./14 kg.	2,000 lbs./900 kg.
50013-44	7/16-in.	.49 lbs./22 kg.	3,000 lbs./1,362 kg.
50013-50	1/2-in.	.74 lbs./34 kg.	4,000 lbs./1,816 kg.
50013-63	5/8-in.	1.44 lbs./65 kg.	6,500 lbs./2,951 kg.
50013-75	3/4-in.	2.16 lbs./98 kg.	9,500 lbs./4,313 kg.
50013-88 NEW	7/8-in.	3.37 lbs./1.52 kg.	13,000 lbs./5,896 kg.
50013-100 NEW	1-in.	5.30 lbs./2.4 kg.	17,000 lbs./7,711 kg.

	A	B	C	D	E	F	G
50013-31	.81	2.25	1.25	.53	Ø3/8	Ø.31	1.00
50013-38	.94	2.61	1.44	.66	Ø7/16	Ø.38	1.13
50013-44	1.06	3.01	1.69	.72	Ø1/2	Ø.44	1.25
50013-50	1.19	3.34	1.88	.81	Ø5/8	Ø.50	1.38
50013-63	1.50	4.04	2.41	1.06	Ø3/4	Ø.63	1.88
50013-75	1.75	5.04	2.84	1.25	Ø7/8	Ø.75	2.13
50013-88	2.00	5.86	3.31	1.44	Ø1.00	Ø.75	2.38
50013-100	2.31	6.63	3.75	1.69	Ø1.13	Ø.75	2.63

Clevis Pin Anchor Shackle — Galvanized and individually polybagged

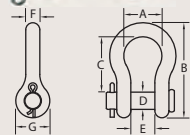

PART NUMBER	SIZE	WEIGHT	WLL
50014-50	1/2-in.	.74 lbs./34 kg.	4,000 lbs./1,816 kg.
50014-63	5/8-in.	1.44 lbs./65 kg.	6,500 lbs./2,951 kg.

	A	B	C	D	E	F	G
50014-50	1.19	3.39	1.88	Ø5/8	.81	Ø.50	1.38
50014-63	1.50	4.17	2.41	Ø3/4	1.06	Ø.63	1.88

Quick Links — Zinc plated clear chromate and individually polybagged

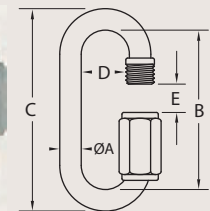

PART NUMBER	SIZE	WEIGHT	WLL
50016-25	1/4-in.	.062 lbs./028 kg.	880 lbs./399 kg.
50016-31	5/16-in.	.154 lbs./07 kg.	1,760 lbs./799 kg.
50016-38	3/8-in.	.198 lbs./90kg.	2,200 lbs./998 kg.

	A	B	C	D	E
50016-25	.235	1.85	2.31	.51	.32
50016-31	.313	2.32	2.95	.65	.41
50016-38	.350	2.54	3.22	.67	.43

CHAIN HARDWARE

Twin Clevis G70

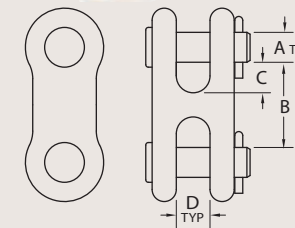

Forged steel with zinc plated gold chromate and individually polybagged

PART NUMBER	SIZE	WEIGHT	WLL
50017-10	1/4-in. – 5/16-in.	.30 lbs./14 kg.	4,700 lbs./2,130 kg.
50017-11	3/8-in.	.40 lbs./18 kg.	6,600 lbs./2,990 kg.
50017-12	7/16-in – 1/2-in.	.98 lbs./44 kg.	11,300 lbs./5,130 kg.

	A	B	C	D
50017-10	.38	1.18	.43	.47
50017-11	.47	1.34	.48	.53
50017-12	.56	1.75	.63	.65

Slip Hooks G70 without Safety Latch

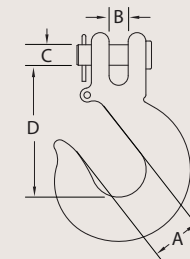

Forged steel with zinc plated gold chromate and individually polybagged

PART NUMBER	SIZE	WEIGHT	WLL
50019-10	1/4-in.	.44 lbs./20 kg.	3,150 lbs./1,430 kg.
50019-11	5/16-in.	.75 lbs./34 kg.	4,700 lbs./2,130 kg.
50019-12	3/8-in.	1.13 lbs./51 kg.	6,600 lbs./2,990 kg.
50019-13	1/2-in.	2.75 lbs./1.25 kg.	11,300 lbs./5,130 kg.

	A	B	C	D
50019-10	.94	.44	.38	2.44
50019-11	1.06	.41	.44	2.72
50019-12	1.31	.59	.47	3.25
50019-13	1.75	.75	.63	4.00

Slip Hooks G70 with Safety Latch

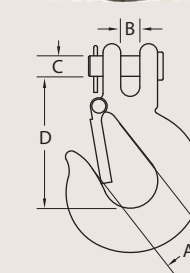

Forged steel with zinc plated gold chromate and individually polybagged

PART NUMBER	SIZE	WEIGHT	WLL
50019-20	1/4-in.	.59 lbs./27 kg.	3,150 lbs./1,430 kg.
50019-21	5/16-in.	.92 lbs./42 kg.	4,700 lbs./2,130 kg.
50019-22	3/8-in.	1.32 lbs./60 kg.	6,600 lbs./2,990 kg.
50019-23	1/2-in.	2.90 lbs./1.32 kg.	11,300 lbs./5,130 kg.

	A	B	C	D
50019-20	.94	.44	.38	2.44
50019-21	1.06	.41	.44	2.72
50019-22	1.31	.59	.47	3.25
50019-23	1.75	.75	.63	4.00

EZ BINDER®



50140-10
EZ Binder
WLL: 5,400 lbs./2,450 kg.
Weight: 11.5 lbs./5.22 kg.



- ▶ Ratchet design is easy to tension and release
- ▶ Extra long handle provides mechanical advantage
- ▶ Durable contoured handle grip for comfortable operation
- ▶ Heavy gauge steel construction with electro zinc plating
- ▶ Dual solid gears distribute tensioning forces evenly
- ▶ Free wheel function for quick take up
- ▶ Quality grade 100 load chain is used in binder
- ▶ Use with 5/16-in grade 70 or 3/8-in grade 43 binder chains
- ▶ Swiveling grab hooks for ease of use
- ▶ Will take up 12-in of chain during tensioning

CHAIN LOAD BINDERS

All traditional chain load binders are constructed of drop forged steel for strength and durability and were designed to be used with NACM standard chain. They are available in traditional Lever, Recoilless and Ratcheting models, and are finished in a red E-coat paint. They meet or exceed WSTDA T-6 standards.

WARNING: Each Ancra chain binder is supplied with a tag containing warnings and instructions. Read all warnings and instructions before use. For chain securement systems, the rated WLL of the binder should be higher than or equal to the rated WLL of the chain size and grade being used. The WLL rating for a securement system is determined by the lowest WLL of any component of the system.

Lever Chain Load Binders



- 45943-12** 1/4-in. Lever Load Binder. Use with 1/4 inch G43 chain. WLL: 2,600 lbs./1,180 kg. Weight: 3.5 lbs./1.59 kg.
- 45943-10** 5/16-in. Lever Load Binder. Use with 5/16 G70 or 3/8 G43 chain. WLL: 5,400 lbs./2,450 kg. Weight: 7.9 lbs./3.59 kg.
- 45943-10HD** 5/16-in, Heavy-Duty Lever Load Binder. Use with 5/16 G70 or 3/8 G70 chain. WLL: 6,600 lbs./2,990 kg. Weight: 9.4 lbs./4.3 kg.
- 45943-11** 3/8-in Lever Load Binder. Use with 3/8 G70 or 1/2 G43 chain. WLL: 9,200 lbs./4,170 kg. Weight: 11.9 lbs./5.4 kg.
- 45943-13** 1/2-in Lever Load Binder. Use with 1/2 G70 or 5/8 G43 chain. WLL: 13,000 lbs./5,910 kg. Weight: 20.8 lbs./9.44 kg.

Recoilless Lever Chain Load Binders

- 45943-14** 5/16-in. Lever Load Binder. Use with 5/16 G70 or 3/8 G43 chain. WLL: 5,400 lbs./2,450 kg. Weight: 9.0 lbs./4.09 kg.



CHAIN LOAD BINDERS

Ratcheting Chain Load Binders



- 45943-20** 5/16-in Ratchet Load Binder. Use with 5/16 G70 or 3/8 G43 chain. WLL: 5,400 lbs./2,450 kg. Weight: 10.4 lbs./4.72 kg.
- 45943-20HD** 5/16-in, Heavy-Duty Ratchet Load Binder. Use with 5/16 G70 or 3/8 G70 chain. WLL: 6,600 lbs./2,990 kg. Weight: 10.5 lbs./4.8 kg.
- 45943-21** 3/8-in Ratchet Load Binder. Use with 3/8 G70 or 1/2 G43 chain. WLL: 9,200 lbs./4,170 kg. Weight: 11.8 lbs./5.36 kg.
- 45943-23** 1/2-in Ratchet Load Binder. Use with 1/2 G70 or 5/8 G43 chain. WLL: 13,000 lbs./5,910 kg. Weight: 15.7 lbs./7.13 kg.

XHD™ Chain Binders



EXTRA SECURITY. Constructed of drop forged steel and designed for durability and superior performance, XHD binders exceed WSTDA T-6 standards. The high visibility yellow E-coat finish protects against harsh elements and extreme road conditions. Available in 2 sizes: 5/16-in – 3/8-in x 6,600 lbs. and 3/8-in – 1/2-in x 9,200 lbs. 50360 binders are the original two-piece handle design that allows the main gear to be welded to the barrel making a more durable design than the standard binders in which the main gear is pinned to the barrel.

- ▶ Forged alloy steel
- ▶ Stronger two-piece handle design with compression spring assembly
- ▶ Welded gear assembly to barrel
- ▶ Pre-lubricated Acme threaded screws
- ▶ Internal thread stops to prevent over-extension and loss of capacity
- ▶ 6-in take-up

- 50360-20** Chain size: 5/16-in. – 3/8-in. WLL: 6,600 lbs./3,000 kg. Weight: 12 lbs./5.4 kg.
- 50360-21** Chain size: 3/8-in. – 1/2-in. WLL: 9,200 lbs./4,200 kg. Weight: 13 lbs./5.9 kg.

LEVER BINDER LOCKING CLIP



- 50117-10** Locking clip secures the handle on lever load binders to prevent the handle from opening and releasing chain tension. Yellow powder coated for corrosion protection and visibility. Weight: .40 lbs./0.18 kg.

FLOOR CHAIN TIE DOWNS

Floor chain tie down anchors are available in either weld-on or bolt-on models to meet your specific needs. Each with a working load limit of 6,000 lbs./2,724 kg. Each are made with 3/8-in grade 70 transport chain for strength and durability.

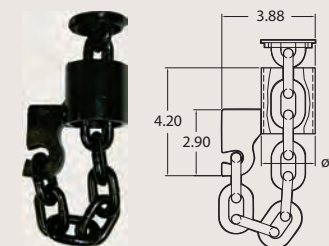

- 49345-10** Weld-on Black E-coat. Weight: 5.6 lbs./2.54 kg.

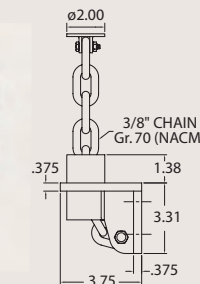

- 49583-10** Bolt-on Plated. Weight: 5.25 lbs./2.38 kg.

ANCRA X-TREME™ WEBBING PERFORMANCE LEADER

As the name implies, Ancra's X-TREME webbing offers our greatest performance, durability, strength and abrasion resistance. Because of its special weave construction and coating process, X-TREME realizes an impressive 80% minimum retained strength after abrasion testing, as opposed to 40% for standard webbing. X-TREME's coating is durable and permanent, and reduces water absorption and freezing. Ancra X-TREME is available in popular winch and ratchet strap models that meet or exceed WSTDA T-1 standards. Custom lengths and end hardware quoted upon request.



ANCRA X-TREME™ WINCH STRAP ASSEMBLIES

Custom lengths and webbing configurations available.

2" WINCH STRAPS — WLL: 3,333 lbs./1,515 kg. using 41632-37 X-TREME Webbing



41659-90-27
2-in. x 27-ft. ANCRA X-TREME Strap w/ 40891-18 Flat Hook
41659-90-30
2-in x 30-ft. ANCRA X-TREME Strap w/ 40891-18 Flat Hook



41659-92-30
2-in x 30-ft. ANCRA X-TREME Strap w/ 43120-13 Wire Hook



41659-93-30
2-in x 30-ft. ANCRA X-TREME Strap w/ 43366-21 Chain Anchor



41659-94-30
2-in x 30-ft. ANCRA X-TREME Strap w/o hardware. For winch to winch applications. Custom lengths available.



ANCRA X-TREME™ WINCH STRAP ASSEMBLIES

3" WINCH STRAPS — WLL: 5,400 lbs./2,450 kg. using 41632-38 X-TREME Webbing



41660-90-30
3-in. x 30-ft. ANCRA X-TREME Strap w/ 41766-18 Flat Hook



41660-93-30
3-in. x 30-ft. ANCRA X-TREME Strap w/ 43366-14 Chain Anchor



41660-95-30
3-in. x 30-ft. ANCRA X-TREME Strap w/o hardware. For winch to winch applications. Custom lengths available.

ANATOMY OF A WINCH STRAP

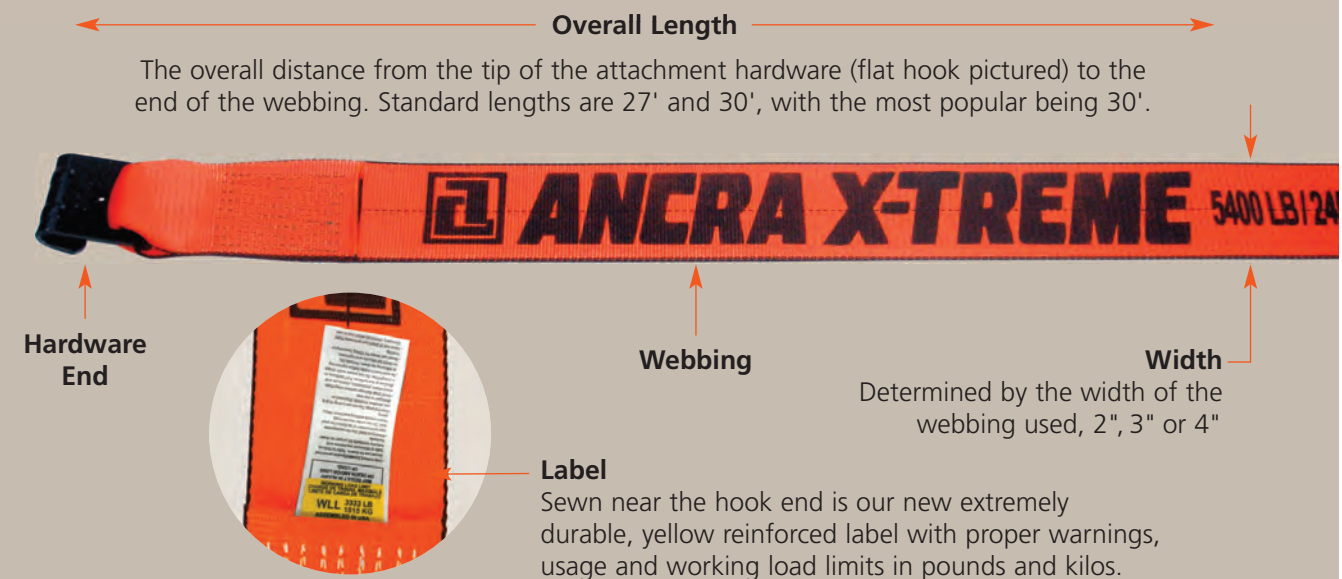

ANCRA X-TREME™ WINCH STRAP ASSEMBLIES

4" WINCH STRAPS — WLL: 5,400 lbs./2,450 kg. using 43797-37 X-TREME Webbing



43795-90-27

4-in. x 27-ft. ANCRA X-TREME Strap w/ 41766-18 Flat Hook

43795-90-30

4-in. x 30-ft. ANCRA X-TREME Strap w/ 41766-18 Flat Hook

43795-90-40

4-in. x 40-ft. ANCRA X-TREME Strap w/ 41766-18 Flat Hook

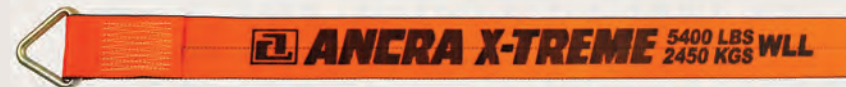

43795-91-27

4-in. x 27-ft. ANCRA X-TREME Strap w/ 41631-12 Delta Ring

43795-91-30

4-in. x 30-ft. ANCRA X-TREME Strap w/ 41631-12 Delta Ring

43795-91-40

4-in. x 40-ft. ANCRA X-TREME Strap w/ 41631-12 Delta Ring



43795-93-30

4-in. x 30-ft. ANCRA X-TREME Strap w/ Half Twisted Loop



43795-95-30

4-in. x 30-ft. ANCRA X-TREME Strap w/ 43366-14 Chain Anchor



43795-92-30

4-in. x 30-ft. ANCRA X-TREME Strap w/o hardware. For winch to winch applications. Custom lengths available.

MILE AFTER MILE, YOUR DEPENDABLE CLASSIC.

Ancra Winch Strap Assemblies combine heavy-duty, wear and weather resistant latex treated polyester webbing with strong, dependable hardware to meet the demanding conditions of flatbed operations. Ancra straps meet FMCSA and CCMTA specifications and are tested for strength and durability. Meets or exceeds WSTDA T-1 Recommended Standard Specifications for synthetic web tie downs.



WINCH STRAP ASSEMBLIES

2" WINCH STRAPS — WLL: 3,333 lbs./1,515 kg. using 41632-46 Webbing



41659-10-27

2-in. x 27-ft. Winch Strap w/ 40891-18 Flat Hook

41659-10-30

2-in. x 30-ft. Winch Strap w/ 40891-18 Flat Hook



41659-11-27

2-in. x 27-ft. Winch Strap w/ 40978-11 Delta Ring

41659-11-30

2-in. x 30-ft. Winch Strap w/ 40978-11 Delta Ring



41659-13-27

2-in. x 27-ft. Winch Strap w/ 43120-13 Wire Hook

41659-13-30

2-in. x 30-ft. Winch Strap w/ 43120-13 Wire Hook



41659-15-27

2-in. x 27-ft. Winch Strap w/ 43366-21 Chain Anchor

41659-15-30

2-in. x 30-ft. Winch Strap w/ 43366-21 Chain Anchor



41659-16-30

2-in. x 30-ft. Winch Strap w/o hardware for winch to winch application. Custom lengths available.

WINCH STRAP ASSEMBLIES

3" WINCH STRAPS — WLL: 5,400 lbs./2,450 kg. using 41632-14 Webbing



41660-10-27

3-in. x 27-ft. Winch Strap w/
41766-18 Flat Hook

41660-10-30

3-in. x 30-ft. Winch Strap w/
41766-18 Flat Hook



41660-14-27

3-in. x 27-ft. Winch Strap w/
43366-14 Chain Anchor

41660-14-30

3-in. x 30-ft. Winch Strap w/
43366-14 Chain Anchor



41660-18-27

3-in. x 27-ft. Winch Strap w/
43120-20 Wire Hook

41660-18-30

3-in. x 30-ft. Winch Strap w/
43120-20 Wire Hook



41660-17-30

3-in. x 30-ft. strap w/o hardware for winch to winch application.
Custom lengths available.

4" WINCH STRAPS — WLL: 5,400 lbs./2,450 kg. using 43797-12 Webbing



43795-10-27

4-in. x 27-ft. Winch Strap w/
41766-18 Flat Hook

43795-10-40

4-in. x 40-ft. Winch Strap w/
41766-18 Flat Hook



43795-11-27

4-in. x 27-ft. Winch Strap w/
41631-12 Delta Ring

43795-11-40

4-in. x 40-ft. Winch Strap w/
41631-12 Delta Ring

43795-10-30

4-in. x 30-ft. Winch Strap w/
41766-18 Flat Hook

43795-10-50

4-in. x 50-ft. Winch Strap w/
41766-18 Flat Hook

43795-11-30

4-in. x 30-ft. Winch Strap w/
41631-12 Delta Ring

43795-11-50

4-in. x 50-ft. Winch Strap w/
41631-12 Delta Ring

43795-10-35

4-in. x 35-ft. Winch Strap w/
41766-18 Flat Hook

43795-11-35

4-in. x 35-ft. Winch Strap w/
41631-12 Delta Ring



43795-13-30

4-in. x 30-ft. Winch Strap w/
Half Twisted Loop

43795-13-65

4-in. x 65-ft. Winch Strap w/
Half Twisted Loop



43795-14-27

4-in. x 27-ft. Winch Strap w/
43365-12 Grab Hook

43795-14-30

4-in. x 30-ft. Winch Strap w/
43365-12 Grab Hook

43795-13-45

4-in. x 45-ft. Winch Strap w/
Half Twisted Loop

43795-13-75

4-in. x 75-ft. Winch Strap w/
Half Twisted Loop

43795-13-50

4-in. x 50-ft. Winch Strap w/
Half Twisted Loop

WINCH STRAP ASSEMBLIES

4" WINCH STRAPS — WLL: 5,400 lbs./2,450 kg. using 43797-12 Webbing



43795-15-27

4-in. x 27-ft. Winch Strap w/
43366-14 Chain Anchor

43795-15-30

4-in. x 30-ft. Winch Strap w/
43366-14 Chain Anchor



43795-19-30

4-in. x 30-ft. Winch Strap w/o hardware for winch to winch application. Custom lengths available.



43795-40-30

4-in. x 30-ft. Winch Strap w/ 41766-18 Flat Hook.
using 43797-19 Blue Webbing.



43795-60-30

4-in. x 30-ft. Winch Strap w/ 41766-18 Flat Hook.
using 43797-23 Crimson Red Webbing.

ROLL-ON/ROLL-OFF CONTAINER STRAPS

STANDARD



49526-10

4-in. x 5-ft. Strap w/ 48968-11 Container Hook.
WLL: 5,400 lbs./2,450 kg.



49526-11

4-in. x 5-ft. Strap w/ 48968-11 Container Hook and Sewn Loop end. WLL: 5,400 lbs./2,450 kg.

ANCRA X-TREME™



49526-90

4-in. x 5-ft. Ancra X-TREME Strap w/ 48968-11 Container Hook.
WLL: 5,400 lbs./2,450 kg.



49526-91

4-in. x 5-ft. Ancra X-TREME Strap w/ 48968-11 Container Hook and Sewn loop end. WLL: 5,400 lbs./2,450 kg.

ENGINEERED FOR STRENGTH AND DURABILITY

Ancra Ratchet Buckle Strap Assemblies have redefined the industry standard. Now with the tested and proven 80% retained strength of Ancra X-TREME™ Webbing, as opposed to 40% for standard webbing, and the integrity of our ratchet buckles, these assemblies surpass the others. A complete line of Ancra's standard and heavy-duty assemblies and accessories can meet all your specific requirements.

- ▶ Custom lengths and a wide range of end hardware are available.
- ▶ Complies with WSTDA T-1 Standards
- ▶ Webbing meets or exceeds WSTDA T-4 Standards
- ▶ Standard fixed end length is 18-in., unless otherwise specified.



ANCRA X-TREME™ RATCHET STRAP ASSEMBLIES

2" ANCRA X-TREME RATCHET STRAPS USING 41632-37 WEBBING WITH LONG-WIDE HANDLE RATCHET BUCKLE 44587-10 — WLL: 3,333 lbs./1,515 kg.



45982-90-27
2-in. x 27-ft. ANCRA X-TREME Ratchet Strap w/ 40891-18 Flat Hooks.

45982-90-30
2-in. x 30-ft. ANCRA X-TREME Ratchet Strap w/ 40891-18 Flat Hooks.



45982-93-30
2-in. x 30-ft. ANCRA X-TREME Ratchet Strap w/ 43366-21 Chain Anchors. Fixed End 33-in.



45982-95-27
2-in. x 27-ft. ANCRA X-TREME Ratchet Strap w/ 43120-13 Wire Hooks.

45982-95-30
2-in. x 30-ft. ANCRA X-TREME Ratchet Strap w/ 43120-13 Wire Hooks.

3" ANCRA X-TREME RATCHET STRAPS USING 41632-38 WEBBING WITH RATCHET BUCKLE 48965-10 — WLL: 5,400 lbs./2,450 kg.



48987-90-27
3-in. x 27-ft. ANCRA X-TREME Ratchet Strap w/ 41766-18 Flat Hooks. Fixed End 22-in.

48987-90-30
3-in. x 30-ft. ANCRA X-TREME Ratchet Strap w/ 41766-18 Flat Hooks. Fixed End 22-in.



48987-92-27
3-in. x 27-ft. ANCRA X-TREME Ratchet Strap w/ 43366-14 Chain Anchors. Fixed End 37-in.

48987-92-30
3-in. x 30-ft. ANCRA X-TREME Ratchet Strap w/ 43366-14 Chain Anchors. Fixed End 37-in.

ANCRA X-TREME™ RATCHET STRAP ASSEMBLIES

4" ANCRA X-TREME RATCHET STRAPS USING 43797-37 WEBBING WITH RATCHET BUCKLE 49349-10 — WLL: 5,400 lbs./2,450 kg.



49346-90-27
4-in. x 27-ft. ANCRA X-TREME Ratchet Strap w/ 41766-18 Flat Hooks. Fixed End 20-in.

49346-90-30
4-in. x 30-ft. ANCRA X-TREME Ratchet Strap w/ 41766-18 Flat Hooks. Fixed End 20-in.



49346-91-27
4-in. x 27-ft. ANCRA X-TREME Ratchet Strap w/ 43366-14 Chain Anchors. Fixed End 35-in.

49346-91-30
4-in. x 30-ft. ANCRA X-TREME Ratchet Strap w/ 43366-14 Chain Anchors. Fixed End 35-in.



49346-93-27
4-in. x 27-ft. ANCRA X-TREME Ratchet Strap w/ 43120-20 Wire Hooks. Fixed End 20-in.

49346-93-30
4-in. x 30-ft. ANCRA X-TREME Ratchet Strap w/ 43120-20 Wire Hooks. Fixed End 20-in.

ANATOMY OF A RATCHET STRAP

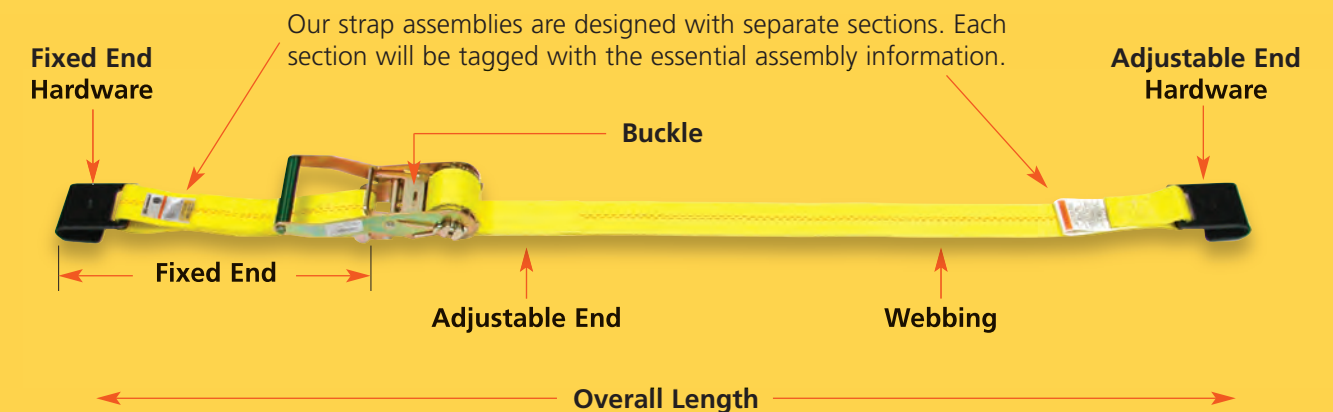

The distance between extreme end bearing points of the web tie down assembly, including the fittings. Standard fixed end length is 18" (33" for chain anchor straps). This puts the ratchet in the optimum position on the side of the trailer.

RATCHET STRAP ASSEMBLIES

The strength of Ancra Ratchet Strap Assemblies reflects the strength of Ancra's reputation in the Transportation Industry. Our heavy-duty, weather resistant straps and solid, reliable hardware have met the demands of the road for 50 years. Our straps are stringently tested for strength and durability in order to bear the Ancra name.

2" RATCHET BUCKLE STRAPS USING 41632-46 WEBBING WITH LONG-WIDE HANDLE RATCHET BUCKLE 44587-10 — WLL: 3,333 lbs./1,515 kg.



45982-10
2-in. x 27-ft. Ratchet Strap w/
40891-18 Flat Hooks.

45982-11
2-in. x 30-ft. Ratchet Strap w/
40891-18 Flat Hooks.



45982-15
2-in. x 27-ft. Ratchet Strap w/
43366-21 Chain Anchors.
Fixed End 33-in.

45982-34
2-in. x 30-ft. Ratchet Strap w/
43366-21 Chain Anchors.
Fixed End 33-in.



45982-19
2-in. x 27-ft. Ratchet Strap w/
40758-11 Twisted Snap Hooks.

45982-36
2-in. x 30-ft. Ratchet Strap w/
40758-11 Twisted Snap Hooks.



45982-42
2-in. x 27-ft. Ratchet Strap w/
43120-13 Wire Hooks.

45982-43
2-in. x 30-ft. Ratchet Strap w/
43120-13 Wire Hooks.

2" RATCHET BUCKLE STRAPS USING 41632-46 WEBBING WITH SHORT-WIDE HANDLE RATCHET BUCKLE 47105-11 — WLL: 3,333 lbs./1,515 kg.



47970-10
2-in. x 27-ft. Ratchet Strap w/
40891-18 Flat Hooks.

47970-11
2-in. x 30-ft. Ratchet Strap w/
40891-18 Flat Hooks.

2" RATCHET BUCKLE STRAPS USING 41632-46 WEBBING WITH STANDARD HANDLE RATCHET BUCKLE 44627-11 — WLL: 3,333 lbs./1,515 kg.



47971-10
2-in. x 27-ft. Ratchet Strap w/
40891-18 Flat Hooks.

47971-11
2-in. x 30-ft. Ratchet Strap w/
40891-18 Flat Hooks.

RATCHET STRAP ASSEMBLIES

3" RATCHET BUCKLE STRAPS USING 41632-14 WEBBING WITH RATCHET BUCKLE 48965-10 — WLL: 5,400 lbs./2,450 kg.



48987-20
3-in. x 27-ft. Ratchet Strap w/
41766-18 Flat Hooks.

48987-21
3-in. x 30-ft. Ratchet Strap w/
41766-18 Flat Hooks.



48987-24
3-in. x 27-ft. Ratchet Strap w/
43366-14 Chain Anchors. Fixed End 33-in.

48987-25
3-in. x 30-ft. Ratchet Strap w/
43366-14 Chain Anchors. Fixed End 33-in.



48987-28
3-in. x 27-ft. Ratchet Strap w/
43120-20 Wire Hook.

48987-29
3-in. x 30-ft. Ratchet Strap w/
43120-20 Wire Hook.

4" RATCHET BUCKLE STRAPS USING 43797-12 WEBBING WITH RATCHET BUCKLE 49349-10 — WLL: 5,400 lbs./2,450 kg.



49346-10
4-in. x 27-ft. Ratchet Strap w/
41766-18 Flat Hooks.

49346-11
4-in. x 30-ft. Ratchet Strap w/
41766-18 Flat Hooks.

WLL: 5,400 lbs./2,450 kg.



49346-14
4-in. x 27-ft. Ratchet Strap w/
43366-14 Chain Anchors. Fixed End 33-in.

49346-15
4-in. x 30-ft. Ratchet Strap w/
43366-14 Chain Anchors. Fixed End 33-in.

4" RATCHET BUCKLE STRAPS USING 41632-15 WEBBING WITH RATCHET BUCKLE 49349-10 — WLL: 6,600 lbs./3,000 kg.



49346-12
4-in. x 27-ft. Ratchet Strap w/
43120-20 Narrow Wire Hooks.

49346-13
4-in. x 30-ft. Ratchet Strap w/
43120-20 Narrow Wire Hooks.

WEB KEEPER RATCHET STRAP ASSEMBLIES



Keep your excess webbing neat and secure with our new patented Web Keeper Ratchet Buckle Straps.

PATENTED

Tension your strap, roll up excess webbing and store it under the spring-loaded red bar. Straps are available in 30' lengths in flat hook and wire hook models in standard or 27' and 30' X-TREME™ Webbing. These straps have a fixed end length of 18" and meet or exceed WSTDA T-1 Standard Specification for synthetic web tie downs.

2" WEB KEEPER RATCHET BUCKLE STRAPS USING 41632-46 WEBBING WITH LONG-WIDE HANDLE WEB KEEPER RATCHET BUCKLE 50037-10 — WLL: 3,333 lbs./1,515 kg.



45982-11-30-WK

2-in. x 30-ft. Web Keeper Ratchet Strap w/ 40891-18 Flat Hooks.



45982-43-30-WK

2-in. x 30-ft. Web Keeper Ratchet Strap w/ 43120-13 Wire Hooks.

2" WEB KEEPER RATCHET BUCKLE STRAPS USING 41632-37 X-TREME WEBBING WITH LONG-WIDE HANDLE WEB KEEPER RATCHET BUCKLE 50037-10 — WLL: 3,333 lbs./1,515 kg.

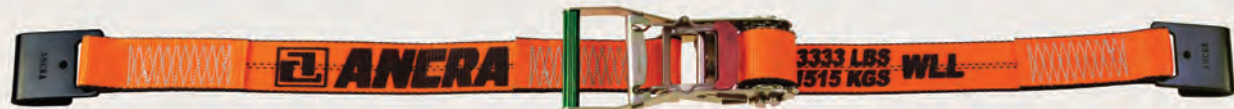

45982-90-27-WK

2-in. x 27-ft. X-TREME Web Keeper Ratchet Strap w/ 40891-18

45982-90-30-WK

2-in. x 30-ft. X-TREME Web Keeper Ratchet Strap w/ 40891-18 Flat Hooks.



45982-95-27-WK

2-in. x 27-ft. X-TREME Web Keeper Ratchet Strap w/ 43120-13 Wire Hooks.

45982-95-30-WK

2-in. x 30-ft. X-TREME Web Keeper Ratchet Strap w/ 43120-13 Wire Hooks.

RATCHET STRAP ASSEMBLIES



FOR ANCRA X-TREME™ 2" RATCHET STRAP ASSEMBLIES

Replacement for:	Part No.	Description
45982-90-27 & -30	10632-90	2" x 18" Fixed end strap w/ 44587-10 Buckle and 40891-18 Flat hook
45982-90-27 & -30, 45982-90-27-WK, 45982-90-30-WK	10632-90-28	2" x 28' Adjustable end strap w/ 40891-18 Flat hook
45982-93-30	10632-93	2" x 33" Fixed end strap w/ 44587-10 Buckle and 43366-21 Chain Anchor
45982-93-30	10632-93-28	2" x 28' Adjustable end strap w/ 43366-21 Chain Anchor
45982-95-27 & -30	10632-95	2" x 18" Fixed end strap w/ 44587-10 Buckle and 43120-13 Wire hook
45982-95-27 & -30, 45982-95-27-WK, 45982-95-30-WK	10632-95-28	2" x 28' Adjustable end strap w/ 43120-13 Wire hook

FOR ANCRA X-TREME 3" RATCHET STRAP ASSEMBLIES

48987-90-27 & -30	10633-90	3" x 22" Fixed end strap w/ 48965-10 Buckle and 41766-18 Flat hook
48987-90-27 & -30	10633-90-28	3" x 28' Adjustable end strap w/ 41766-18 Flat hook
48987-92-27 & -30	10633-92	3" x 36" Fixed end strap w/ 48965-10 Buckle and 43366-14 Chain Anchor
48987-92-27 & -30	10633-92-28	3" x 28' Adjustable end strap w/ 43366-14 Chain Anchor

FOR ANCRA X-TREME 4" RATCHET STRAP ASSEMBLIES

49346-90-27 & -30	10634-90	4" x 18" +/- 2" Fixed end strap w/ 49349-10 Buckle and 41766-18 Flat hook
49346-90-27 & -30	10634-90-28	4" x 28' Adjustable end strap w/ 41766-18 Flat hook
49346-91-27 & -30	10634-91	4" x 33" +/- 2" Fixed end strap w/ 49349-10 Buckle and 43366-14 Chain Anchor
49346-91-27 & -30	10634-91-28	4" x 28' Adjustable end strap w/ 43366-14 Chain Anchor
49346-93-27 & -30	10634-93	4" x 18" +/- 2" Fixed end strap w/ 49349-10 Buckle and 43120-20 Wire hook
49346-93-27 & -30	10634-93-28	4" x 28' Adjustable end strap w/ 43120-20 Wire hook

FOR STANDARD 2" RATCHET STRAP ASSEMBLIES

Replacement for:	Part No.	Description
45982-10 & -11, 47970-10 & -11, 47971-10 & -11, 45982-10-27-WK, 45982-11-30-WK	48922-10	2" x 18" Fixed end strap w/ 40891-18 Flat hook & loop end
45982-42 & -43	48922-13	2" x 18" Fixed end strap w/ 43120-13 Wire hook & loop end
45982-15 & -34, 45982-42-27-WK, 45982-43-30-WK	48922-16	2" x 33" Fixed end strap w/ 43366-21 Chain Anchor & loop end
45982-10 & -11	49347-10	2" x 18" Fixed end strap w/ 40891-18 Flat hook & 44587-10 Buckle
45982-42 & -43	49347-19	2" x 18" Fixed end strap w/ 43120-13 Wire hook & 44587-10 Buckle
45982-15 & -34	49347-28	2" x 33" Fixed end strap w/ 43366-21 Chain Anchor & 44587-10 Buckle
45982-10, 47970-10, 47971-10	49347-11	2" x 25' Adjustable end strap w/ 40891-18 Flat hook
45982-42	49347-20	2" x 25' Adjustable end strap w/ 43120-13 Wire hook
45982-15	49347-29	2" x 25' Adjustable end strap w/ 43366-21 Chain Anchor
45982-11, 47970-11, 47971-11	49347-12	2" x 28' Adjustable end strap w/ 40891-18 Flat hook
45982-43	49347-21	2" x 28' Adjustable end strap w/ 43120-13 Wire hook
45982-34	49347-30	2" x 28' Adjustable end strap w/ 43366-21 Chain Anchor

RATCHET STRAP ASSEMBLIES

FOR STANDARD 3" RATCHET STRAP ASSEMBLIES

Replacement for:	Part No.	Description
48987-20 & -21	48922-11	3" x 18" Fixed end strap w/ 41766-18 Flat hook & loop end
48987-24 & -25	48922-17	3" x 33" Fixed end strap w/ 43366-14 Chain Anchor & loop end
48987-22 & -23	48922-20	3" x 18" Fixed end strap w/ 43365-12 Grab hook & loop end
48987-20 & -21	49347-13	3" x 18" Fixed end strap w/ 41766-18 Flat hook & 48965-10 Buckle
48987-24 & -25	49347-31	3" x 33" Fixed end strap w/ 43366-14 Chain Anchor & 48965-10 Buckle
48987-22 & -23	49347-40	3" x 18" Fixed end strap w/ 43365-12 Grab hook & 48965-10 Buckle
48987-20	49347-14	3" x 25' Adjustable end strap w/ 41766-18 Flat hook
48987-24	49347-32	3" x 25' Adjustable end strap w/ 43366-14 Chain Anchor
48987-22	49347-41	3" x 25' Adjustable end strap w/ 43365-12 Grab hook
48987-21	49347-15	3" x 28' Adjustable end strap w/ 41766-18 Flat hook
48987-25	49347-33	3" x 28' Adjustable end strap w/ 43366-14 Chain Anchor
48987-23	49347-42	3" x 28' Adjustable end strap w/ 43365-12 Grab hook

FOR STANDARD 4" RATCHET STRAP ASSEMBLIES

49346-10 & -11	48922-12	4" x 18" Fixed end strap w/ 41766-18 Flat hook & loop end
49346-12 & -13	48922-15	4" x 18" Fixed end strap w/ 43120-20 Wire hook & loop end
49346-14 & -15	48922-18	4" x 33" Fixed end strap w/ 43366-14 Chain Anchor & loop end
49346-10 & -11	49347-16	4" x 18" Fixed end strap w/ 41766-18 Flat hook & 49349-10 Buckle
49346-12 & -13	49347-25	4" x 18" Fixed end strap w/ 43120-20 Wire hook & 49349-10 Buckle
49346-14 & -15	49347-34	4" x 33" Fixed end strap w/ 43366-14 Chain Anchor & 49349-10 Buckle
49346-10	49347-17	4" x 25' Adjustable end strap w/ 41766-18 Flat hook
49346-12	49347-26	4" x 25' Adjustable end strap w/ 43120-20 Wire hook
49346-14	49347-35	4" x 25' Adjustable end strap w/ 43366-14 Chain Anchor
49346-11	49347-18	4" x 28' Adjustable end strap w/ 41766-18 Flat hook
49346-13	49347-27	4" x 28' Adjustable end strap w/ 43120-20 Wire hook
49346-15	49347-36	4" x 28' Adjustable end strap w/ 43366-14 Chain Anchor

GEAR DRIVE TENSIONER

PATENTED

Secures bottled gases. Ergonomically designed to secure bottled gases and other sensitive and specialized cargo, our new patented Gear Drive Tensioner with gradual strap tensioning and release provides more control than a ratchet buckle. Locking the 2-inch strap in place every 1/28th of a spool rotation, the worm gear self-locks against back drive to stay closed. The folding handle locks the gear system and tension when folded over, and magnetic detent holds it closed.

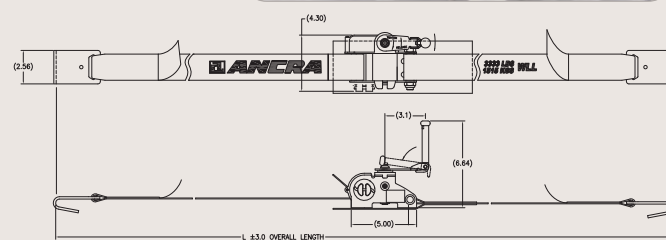

Other key features:

- ▶ Assembly strength: 3,333 lbs. WLL
- ▶ Standard 12-ft length with custom lengths available
- ▶ Gradually release strap tension by turning the handle counterclockwise
- ▶ Gear housing made from high impact polycarbonate material that withstands temperatures from -40 F to + 180 F
- ▶ The gear drive system provides improved mechanical advantage so it requires less hand pressure to tighten the strap as compared to a typical ratchet buckle.

NEW 10939-10 Strap Assembly with Snap Hooks

NEW 10939-12 Strap Assembly with Flat Hooks



FLATBED ACCESSORIES

Cable Assemblies with Chain Anchor



Ankra's heavy-duty cable assemblies with zinc-plated gold chromate chain anchor can be used on cable, combination winches, or web winches with side washers to prevent binding. Constructed of galvanized aircraft cable with grade 70 NACM-compliant chain anchor. The cable assemblies are available in 7/32", 1/4" and 5/16" diameter cable in 30' and 32' lengths. The chain anchors are 19" in length.

49828-12-30	7/32" x 30' Weight: 4.9 lbs./2.2 kg. WLL: 1,867 lbs./848 kg.
49828-12-32	7/32" x 32' Weight: 5.1 lbs./2.3 kg. WLL: 1,867 lbs./848 kg.
49828-10-30	1/4" x 30' Weight: 5.4 lbs./2.45 kg. WLL: 2,300 lbs./1,050 kg.
49828-10-32	1/4" x 32' Weight: 5.8 lbs./2.6 kg. WLL: 2,300 lbs./1,050 kg.
49828-11-30	5/16" x 30' Weight: 7.9 lbs./3.6 kg. WLL: 3,300 lbs./1,500 kg.
49828-11-32	5/16" x 32' Weight: 8.4 lbs./3.8 kg. WLL: 3,300 lbs./1,500 kg.

AN CRA X-TREME™ ROPE TIE DOWN

Lightweight solution for heavyweight loads. When hauling heavy duty loads like timber, Ankra X-Treme Rope Tie Downs provide you with a lightweight alternative to steel cable tie downs. Made of ultra high molecular weight polyethylene for high strength and low stretch, the user-friendly rope with 3/8" diameter and breaking strength of 18,000 pounds will not develop kinks or broken wires.

Rope Tie Downs also feature:

- ▶ Spliced eye loop on the end for connection to three-bar winch
- ▶ 21"-long chain anchor on opposite end is made with 5/16" Grade 70 chain and grab hook
- ▶ Complies with FMCSA and has rated WLL of 3600 lbs./1,635 kg
- ▶ Metal tag attached is marked, "Ankra, 50404-10, WLL 3600 lbs, 1365 kg"



NEW

Ankra X-Treme Rope Tie Down
50404-10-33 Length: 33 ft.
50404-10-36 Length: 36 ft.
50404-10-40 Length: 40 ft.

TOSS 'N TIE

You don't have to throw your tie downs over the load and equipment and risk harm to yourself, others, or your load! Toss 'N Tie is an easy way to get tie downs in place efficiently and safely. Three easy steps:

1. Unroll cord and attach a cargo strap or cargo chain.
2. Toss the Toss 'N Tie ball up and over load.
3. Go to the other side, grab cord and pull your tie down into place.



NEW

50409-10 Single Pack
50409-10-4PK 4 Pack
50409-10-BULK Bulk Packaging

Toss 'N Tie
 Available in 1-pack, 4-pack, and bulk



FLATBED ACCESSORIES

5th Wheel Release Hook

50354-10 With a 5-inch tee-handled grip, the hook end releases the locking pin on a 5th wheel connection. The short angled bar releases the secondary lock found on some models.

- ▶ Chrome plated finish
- ▶ Welded steel construction
- ▶ Total product length: 34.5 inches
- ▶ Weight: 1.89 lbs./.86 kg.



TIE DOWN TIPS

From the Web Sling and Tie Down Association

- ▶ The angle from the horizontal (tie down to trailer deck) has an enormous influence on load securement.
- ▶ If the angle is 90 degrees, the effective downward pressure is 100% of the tie down tension.
- ▶ If the angle is 60 degrees, the effective downward pressure is reduced to 87% of the tie down tension.
- ▶ If the angle is 45 degrees, the effective downward pressure is reduced to 71% of the tie down tension.
- ▶ If the angle is 30 degrees, the effective downward pressure is reduced to 50% of the tie down tension.



Ancra Helps Keep You In Compliance with the Law

Ancra's mobile tie-down-calculator app is available at no cost.

Better safe than sorry. Ancra's free mobile app helps you determine the minimum strap requirements to comply with FMCSA and CCMTA.

Our app lets you work in standard or metric measurements and gives you the option to enter custom article lengths and weights. It will also store Working Load Limits of straps for future use and links to the FMCSA website for more information.

Available on the App Store and on Google Play.

It's free.



Works with iOS and Android mobile devices



From decking systems, track, beams and bars, to strap assemblies and custom nets, Ancra's Interior Van Solutions are made of quality components to secure your loads. Whether your application is standard or heavy-duty, your solution is here.

- Loading systems match your application
- Track treated with high quality finishes for corrosion resistance
- Versatile beams and bars with the best possible strength-to-weight ratio
- Replacement parts for added life and efficiency
- Strength tested and highway proven

VERS-A-DECK®

Maximize your decking. Vers-A-Deck earned its name by allowing users to customize deck heights and accommodate various size and weight loads. By using E Beams and Vers-A-Deck beams on the same track system, you can easily create double decking.

Vers-A-Deck's key benefits:

- ▶ Accommodates Vers-A-Beams and E Beams in the same system at the same deck height
- ▶ Works with Ancra Poly Deckboard for maximum efficiency and flexibility
- ▶ Customized deck heights allows increased load average while avoiding damage from double stacking freight
- ▶ Easy maintenance and repair
- ▶ Stores in the ceiling
- ▶ 2-year warranty.

PATENT PENDING



Vers-A-Deck®

NEXT GENERATION DECKING SYSTEM

The low-profile Vers-A-Deck beam works well with either 16-inch spacing or 24-inch track spacing. The 16-inch spacing has a cargo weight limit rating of 3,000 pounds per 2 pallet decking position (four beams at 750 pounds per beam). With 24-inch spacing, the cargo weight is 2,250 pounds (three beams at 750 pounds per beam). E beams inserted where needed enable flexibility to increase load average. The beams are easily maintained and repaired, and when not in use, store near the ceiling, reducing the chance of being left behind on the loading dock.

E Beams and Vers-A-Deck beams fit standard 4-inch pitch logistics slots for shoring or decking. Beams normally don't require lubrication, but if needed, a high-performance penetrating oil does the trick.

The Vers-A-Deck track, with its standard logistics slots, allows the use of standard logistics straps for securing cargo in place.

NEW 50420-10

Low Profile Beam

WLL Decking: 3,000 lbs./1360 kg.
WLL Shoring: 2,000 lbs./907 kg.
Max Cargo: 750 lbs./340 kg.*
Length: 98.0 to 113.4 in./
249 to 288 cm.
Weight: 19.6 lbs./8.9 kg.



50418 Series
Standard Single
Flush Mount Track.
Bonded Installation
Recessed in Wall Panel



50419 Series
Low Profile Single
Surface Mount Track.
Also available for
bonded installation.

50459-10
Warning,
Instruction and
Maintenance
Placard



*Max cargo is the maximum recommended cargo weight per beam to allow for expected 4G transport dynamics.

LIFT-A-DECK® II

The most popular patented solution for decking loads in trailer and van bodies.

With Ancra's patented adjustable second deck in your trailer, you can carry double the amount of palletized freight, or you can mix loads with only part of the vehicle double decked. Either way, you can increase your payload capacity and your profits. For the loads where you need full height, you simply push the adjustable beams to the roof for convenient and safe storage. There will be no more beams left on the loading dock. With many track styles to choose from, installations can be made on any type of vehicle construction, including sheet and post. Lift-A-Deck II track can also be used with a wide range of Ancra accessories for cargo containment.

Convenient storage.

When not in use, beams are easily pushed to the roof for secure storage. No more lost beams.

Easy operation.

Beams are easily moved by one operator.

Super strength.

Ancra Wide Top Beams have the highest rating in the industry. Working Load Limit – 4,000 lbs./1,816 kg.

Wide range of accessories.

Lift-A-Deck II track can be used for securing loads with cargo straps, tie-offs, and decking/shoring beams.



Fits all trailers.

Available for 96 or 102 inch trailer widths and height can be specified. Track also can be made as an integral part of sidewall structure.

Versatile.

Beams can be adjusted in one-inch increments to accommodate various loads within a trailer. Only Ancra offers this much adjustability.

Snag resistant.

Low profile track design with sloping shoulders helps protect against forklift damage and allows for surface mounting. Standard track length is 72-inches. Custom lengths are available.

Simple, yet secure.

Double engagement lock on the aluminum beam features a simplified trigger release mechanism. Internal locking design helps protect against forklift damage.

LIFT-A-DECK® II

Only Ancra gives you so many decking options.

Cargo beams and Lift-A-Deck beams are rated at Working Load Limits (WLL) that are 1/3 of the breaking strength or failure load capacity of the beams. In order to account for dynamics and vibrations that are experienced during transit and avoid overloading the beams beyond the WLL rating, the actual weight of cargo supported by the beams should be reduced below the rated WLL value of the beam. The allowable weight of cargo supported by the beams should be factored down based on anticipated dynamic G forces expected during transit. Below are typical examples of de-rated weight carrying values for decking systems based on typical 4G transport dynamics.

Recommended Maximum Cargo Weight per 4' Decking Position - lbs	BEAM TYPE	24" Track Spacing		16" Track Spacing	
		S-S-S (single-single-single)	D-S-D (double-single-double)	S-S-S-S (single-single-single-single)	D-S-S-D (double-single-single-double)
	Standard	1100	1650	1650	2200
	Heavy Duty	1500	2250	2250	3000
	Reinforced Wide	2000	3000	3000	4000

Note: A decking position is typically made up of two pallets.

- ▶ Beams can be positioned in one-inch increments for most efficient utilization of space
- ▶ Beams easily moved by just one operator
- ▶ Low Profile locking mechanism to help protect against forklift damage.

STANDARD AND LOW PROFILE BEAMS W/ LOW PROFILE FOOT AND CHANNEL ASSEMBLY



49414-15
Standard LAD Beam
Adjustment range: 95.1" – 105.6"
Weight: 18.1 lbs./8.2 kg.
Decking WLL: 2,200 lbs./999 kg.*
Shoring WLL: 2,200 lbs./999 kg.



49414-19
Heavy Duty LAD Beam
Adjustment range: 95.1" – 105.6"
Weight: 19.7 lbs./8.9 kg.
Decking WLL: 3,000 lbs./1,360 kg.*
Shoring WLL: 2,500 lbs./1,135 kg.

WIDE TOP BEAM W/ LOW PROFILE FOOT AND CHANNEL ASSEMBLY

The textured Beam top surface is 4-1/2" wide to increase the contact area for cargo on the beam deck.



50080-11
Wide Top LAD Beam Assembly
Adjustment range 95.1" – 105.6"
Weight: 24.9 lbs./11.3 kg.
Decking WLL: 4,000 lbs./1,816 kg.*
Not recommended for shoring.



50312-10
Wide Top LAD Beam
w/ Reinforced 1-in. Sides
Adjustment range: 95.1" – 105.6"
Weight: 26.7 lbs./12.1 kg.
Decking WLL: 4,000 lbs./1,814 kg.*
Shoring WLL: 2,500 lbs./1,135 kg.

50312-10-RT Replacement tube for 50312-10. Length 90.71 inches.

* WARNING: Never exceed trailer manufacturer decking load limits. Do not create an unstable, top heavy trailer. Load heavier items on trailer floor.

LIFT-A-DECK® II

BEAM ACCESSORIES AND COMPONENTS — RT Beams have all the required labels.



49414-15-RT
Replacement Tube for 49414-15 Standard
LAD Beam. Length 90.71 inches.
Weight: 11.2 lbs./5.1 kg.

49414-19-RT
Replacement Tube for 49414-19 Heavy-
Duty LAD Beam. Length 90.71 inches.
Weight: 14.3 lbs./6.5 kg.

50080-11-RT
Replacement Tube for 50080-11 Wide
Top LAD Beam. Length 90.71 inches.
Weight: 19.5 lbs./8.8 kg.



49445-12 Beam Release Bar
Length: 52 inches.
Weight: 2.5 lbs./1.14 kg.



49446-10 Lift-A-Deck Kit
Lift-A-Deck Kit includes the
49445-12 Beam Release Bar and 49438-14 Warning, Operations and Maintenance placard. Weight: 2.5 lbs./1.14 kg.



PRODUCT FEATURES

WITH MORE THAN 75,000 SYSTEMS OPERATING YEAR AFTER YEAR WITH LOW MAINTENANCE COSTS, LIFT-A-DECK IS THE DECK SYSTEM MOST REQUESTED BY MAJOR FLEETS.

- + NO TRACK LUBRICATION REQUIRED.
- + SYSTEM TRACK AND FOOT ASSEMBLIES ARE PRECISION MACHINED RESULTING IN SMOOTH SLIDING BEAMS.
- + EVALUATION, TESTING, TRAINING AND INSTALLATION BY CERTIFIED DECK SPECIALISTS WILL HELP DETERMINE THE BEST LAD II SYSTEM FOR YOUR APPLICATION AND ENSURE MAXIMUM EFFICIENCY AND ROI.



50055-10
Beam Release Bar Holder
Weight: .44 lb./0.2 kg.

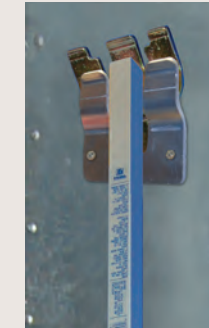

NEW 50486-10 Rubber Beam Stop
Easy to Install. Weight: .05 lb./0.02 kg.



50187-30
Lift-A-Deck II Low Profile Foot and
Tube Assembly. Machined guide
shoe allows for inspection of the
locking elements while foot is
installed in track. Features a coil
spring for optimum service life.
Weight: 3.1 lbs./1.41 kg.



50187-31
Lift-A-Deck II Low Profile Foot
Assembly. Machined guide shoe
allows for inspection of both
locking lugs while beam remains
installed in the track. Features a
coil spring for optimum service life.
Weight: 0.6 lbs./0.27 kg.

AFTERMARKET DECKING SYSTEM BEAMS

AFTERMARKET DECKING BEAMS — OLDER STYLE CAPTIVE BEAM SYSTEMS



49414-21
Standard Aftermarket Beam
Adjustment range 97.3" – 108.8"
Weight: 23.7 lbs./10.76 kg.
Decking WLL: 2,200 lbs./1,000 kg.
Shoring WLL: 1,500 lbs./680 kg.



50191-10
Heavy-Duty Aftermarket Beam
Adjustment range 97.3" – 108.8"
Weight: 25.3 lbs./11.49 kg.
Decking WLL: 2,200 lbs./1,000 kg.
Shoring WLL: 1,500 lbs./680 kg.



50186-10
Wide Top Aftermarket Beam
Adjustment range 97.3" – 108.8"
Weight: 30.5 lbs./13.85 kg.
Decking WLL: 2,500 lbs./1,135 kg.
Not recommended for shoring.

** Note: Also consult trailer or truck body manufacturer for their recommended load capacity of secondary deck.*

AFTERMARKET BEAM ACCESSORIES AND COMPONENTS — RT Beams have all the required labels.



49414-21-RT (shown above)
Replacement Tube for 49414-21 Standard Aftermarket Beam. Length 90.71 inches. Weight: 11.2 lbs./5.1 kg.

50191-10-RT
Replacement Tube for 50191-10 Heavy-Duty Aftermarket Beam. Length 90.71 inches. Weight: 14.3 lbs./6.5 kg.

50186-10-RT
Replacement Tube for 50186-10 Wide Top Aftermarket Beam. Length 90.71 inches. Weight: 19.5 lbs./8.8 kg.

50188-10
Foot and Channel Assembly for 49414-22, 50186-10 and 50191-10 Aftermarket Beams. Weight: 5.9 lbs./2.68 kg.



50194-100
Low Profile Allen Sleeve Nut and Bolt Kit
Kit consists of (1) 50194-10 Bolt and (1) 50194-11 Sleeve Nut. Low profile allen head bolt and sleeve nut with a semi-flush head height of .10". Used for attaching channel assemblies to beams. The bolt has a self locking patch to prevent loosening due to vibration. For 43638, 49039, 49360, 49414, 50080, 50158, 50186, 50191 and 50420 beams. Weight: .10 lb./5 kg.

LIFT-A-DECK® II

Lift-A-Deck® II Track Options

- ▶ Widest choice of track types to meet every application.
- ▶ No track lubrication is required.
- ▶ Beam access slot is provided as standard for all track for easy beam removal and replacement. Standard track length is 72 inches (61 inch loadable). Custom lengths and an installation manual are available upon request.



50192-14-72.00
Standard Single Track

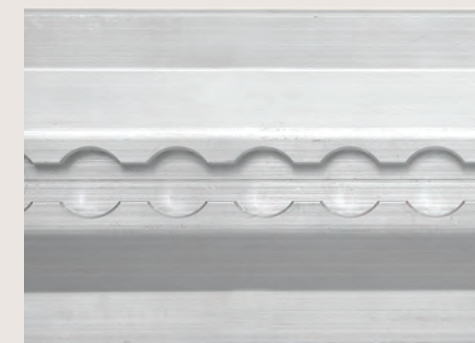
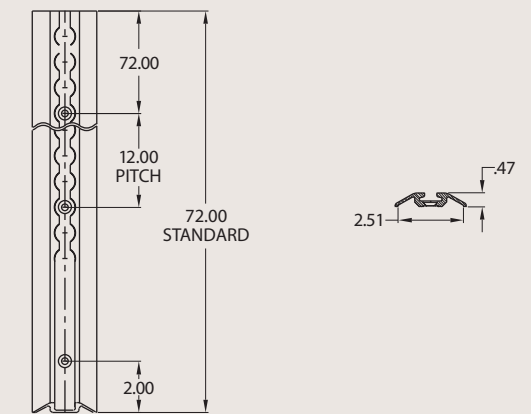

50058-18-72.00
Flanged Single Track. Beveled, Weight: 4.2 lbs./ 1.9 kg.

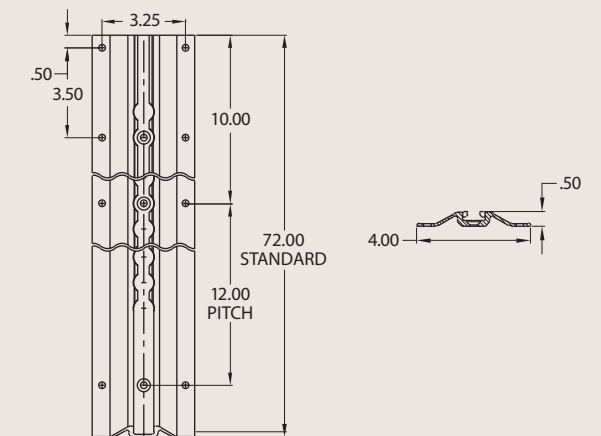

49562-17-72.00
Narrow Single Track

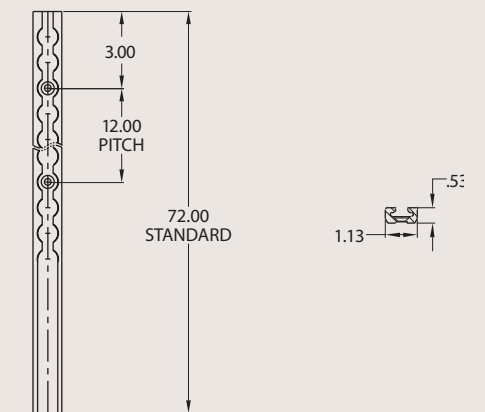

LIFT-A-DECK® II

LIFT-A-DECK® II TRACK OPTIONS

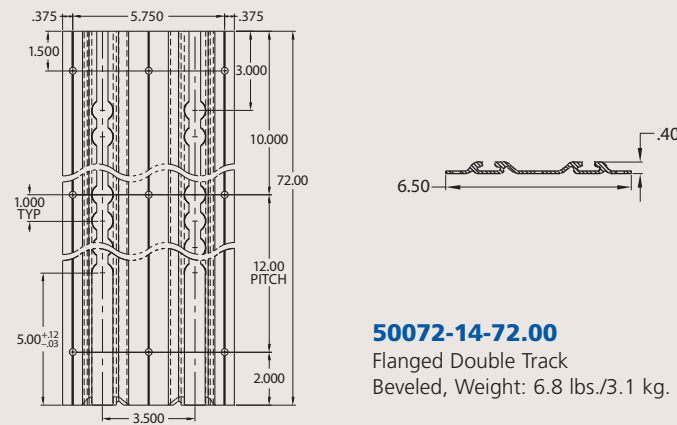

50072-14-72.00
Flanged Double Track
Beveled, Weight: 6.8 lbs./3.1 kg.

LIFT-A-DECK® II LOGISTIC STRAPS



6,000 lb. Polyester Webbing (47200) with Cam Buckle (40880-15) and (50112-10) Single Stud Fitting. Fixed End: 48-in. Working Load Limit: 833 lbs./378 kg.

6,000 lb. Polyester Webbing (47200) with Ratchet Buckle (44258-13) and (50362-11) Double Stud Fitting. Fixed End: 48-in. Working Load Limit: 1,500 lbs./680 kg.

Part No.	Length	Weight
40602-100	12 ft.	1.40 lbs.
40602-101	16 ft.	1.55 lbs.
40602-102	20 ft.	1.70 lbs.

Part No.	Length	Weight
48672-16	12 ft.	2.50 lbs.
48672-17	16 ft.	2.65 lbs.
48672-18	20 ft.	2.80 lbs.

FASTRACK™ LIFT-A-DECK II CONVERSION TRACK

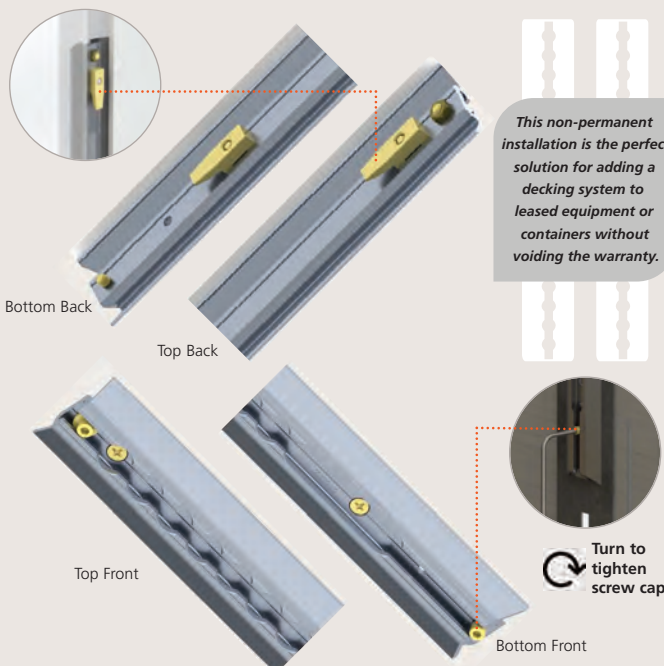

NEW FASTRACK™

PATENT PENDING

50530-10 FasTrack™ Lift-A-Deck II Conversion Track

The FasTrack™ Lift-A-Deck II Conversion system is a single track with brackets attached to the back for mounting into vertical logistics post slots. This track, with addition of a Lift-A-Deck II beam, easily converts a standard dry van trailer into a captive beam Lift-A-Deck II decking trailer without requiring a permanent installation. FasTrack™ provides all the benefits of traditional captive decking systems along with the versatility of short-term usage or customer demonstration.

- ▶ 50530-10 is a 78" long beveled single track assembly.
- ▶ Brackets are spaced every 12" to mount to standard vertical E/A slots on 4" or 6" centers.
- ▶ A beam stop is included at top of the LAD II conversion track. A beam stop should be installed above the insertion slot after a beam has been inserted into the track to captivate the beam.
- ▶ A ¼-20 socket head cap screw, provided with the conversion track, keeps track secured into logistics post.
- ▶ This non-permanent installation is the perfect solution for adding a decking system to leased equipment or containers without voiding the warranty.

LOGIST-A-PANEL™

NEW New levels of Lift-A-Deck and Vers-A-Deck. Logist-A-Panel combines Ancra's proven Lift-A-Deck II beam system with slotted wall panels replacing the standard plywood or liner panel inside your trailer to create highly customizable shoring and strapping options for loads of all sizes. Versatile and efficient with the strength and durability Lift-A-Deck II is known for, Logist-A-Panel wall system adds capacity to customize to your specific load. A retrofit kit contains preassembled logistics panels with Lift-A-Deck II track in a variety of options including flush and surface mount, beams and accessories kit for quick and easy installation. Quickly convert a 24-inch post spaced trailer to 16-inch post spacing.



Logist-A-Panel.
Surface Mount Track.



PATENTED

Logist-A-Panel.
Standard Single.
Flush Mount Track.
Recessed in Wall Panel.



Logist-A-Panel w/
Beam Release Bar Holder.

POLY DECKBOARD

PATENTED



Poly Deckboard for Lift-A-Deck or Vers-A-Deck System and E Beams

- ▶ Lighter than plywood - Increase trailer capacity
- ▶ Ergonomic - Convenient hand slot
- ▶ Splinter Proof - Reduces labor to clean out trailers and docks - longer life than plywood
- ▶ Stackable - Nests for storage
- ▶ Durable - Reduces purchase frequency
- ▶ Recyclable - Energy savings
- ▶ Tough high density polyethylene has excellent low temperature performance down to -40°F
- ▶ Tested to demonstrate durability under load and vibration at -40°F



50105-11
Poly Deckboard
For beams set at 16" and 24" spacing.
48" x 48" x 2.7"H
Weight: 21 lbs./9.53 kg.

SECURITY DIVIDER & DECKBOARD

Versatile Security Divider & Deckboard.

High density polyethylene panels with hand slots for easy positioning are ideal for moving household items, keeping your freight separate and secure. Used with lockable beams to provide a secure load divider for missed loads. When used as a decking board, the cargo carrying capacity is determined by the beam supporting it.

- ▶ Kit includes 2 lockable E Beams and 2 Panels
- ▶ For use with Standard and Heavy Duty E Beams
- ▶ Splinter proof
- ▶ 3-year Warranty

PATENTED



50514-10

Single Panel

96" h x 48" w x 4" d
Weight: 44 lbs./20 kg.

50515-10

Bulkhead Kit,

2 Panels & 2 HD Lockable Beams

Heavy Duty Beams QTY: 2 (49039-59)
96" h x 96" w x 4" d
Total Kit Weight: 133 lbs./60 kg.

50515-11

Bulkhead Kit,

2 Panels & 2 STD Lockable Beams

Standard Duty Beams QTY: 2 (43638-59)
96" h x 96" w x 4" d
Total Kit Weight: 126 lbs./57 kg.



Panel can also be used as a 4' x 8' decking board.



Lockable E-Beam



KNOCK DOWN PALLET DECK



KNOCK DOWN
PALLET DECK

Collapsible, stackable, durable.

For greater efficiency and safety, the Knock Down Pallet Deck (KDPD) features legs that automatically deploy. When extended, the folding legs interlock with the fixed nesting legs for additional stability and better distribution of weight. A self-contained system, the KDPD needs no extra parts to be lost or damaged. When folded, the pallet nests securely with other KDPD units for an efficient, space-saving solution, 92-inch wide x 47-inch deep x 56-inch high.

NEW 50480-100 Knock Down Pallet Deck
Full Dimensions: 92 in x 56 in x 47 in
Folded Dimensions: 92 in x 47 in x 14.1 in
WLL: 5,500 lbs./2,495 kg.

PATENT PENDING



PALLET DECK



49988-10 Pallet Deck

Add another deck to double your freight and your profits, and reduce damage claims. Pallet Deck is made from 2-inch square tube with zinc flo-coat finish 46-inch deep x 92-inch wide x 56-inch high. WLL: 5,500 lbs./2,495 kg.



RETRACT-A-ROLL PUTS HIGH-SPEED AIRCRAFT-CARGO LOADING IN YOUR TRAILER.



Move 1,000 pound loads with one finger.

Ankra's next-generation retractable roller system lifts cargo so workers can glide it into position for faster loading and unloading. Proven in airports worldwide, the system moves thousands of tons of air cargo every day. Fast loading and unloading reduces handling time, lowers labor costs and speeds turn-arounds. Retract-A-Roll is extremely versatile—it handles air freight, palletized freight and instantly converts to a flat floor for handling general freight.

Operated by pneumatics from the truck's existing air supply, it is extremely rugged.



Air bag assembly protection.
Ankra's exclusive air bag sleeve offers 360° protection plus the industry's best air bag warranty.

Steel top plate and rollers fend off forklifts while lower sections are aluminum to reduce weight. All parts are easily accessed for inspection or repair. Centralized weather-proofed controls are simple: one valve raises or lowers rollers.

Now offering composite batten kits.

RETRACT-A-ROLL SPECIFICATIONS

Conveyor width:	4.2 inches (107 mm)
Conveyor height:	2.75 inches (70 mm)
Conveyor weight:	7.2 lbs/ft (10.7 kg/m)
Inflated height:	3.3 inches (84 mm)
Axle spacing:	4", 6" or combination pitch
Conveyor lengths:	8', 10' and 13' (standard) 2.4 m, 3 m, 4 m (standard)
Lifting capacity:	450 lb/ft (671 kg/m)
Operating air pressure:	30 psi / 2 bar
Control box:	Weatherproof with centralized controls



60169-10 Auxiliary Air Tank Kit



Dual Skate Wheels

Retract-A-Roll 2



2-inch rollers have 250 lb/ft (671 kg/m) bearing capacity per roller.

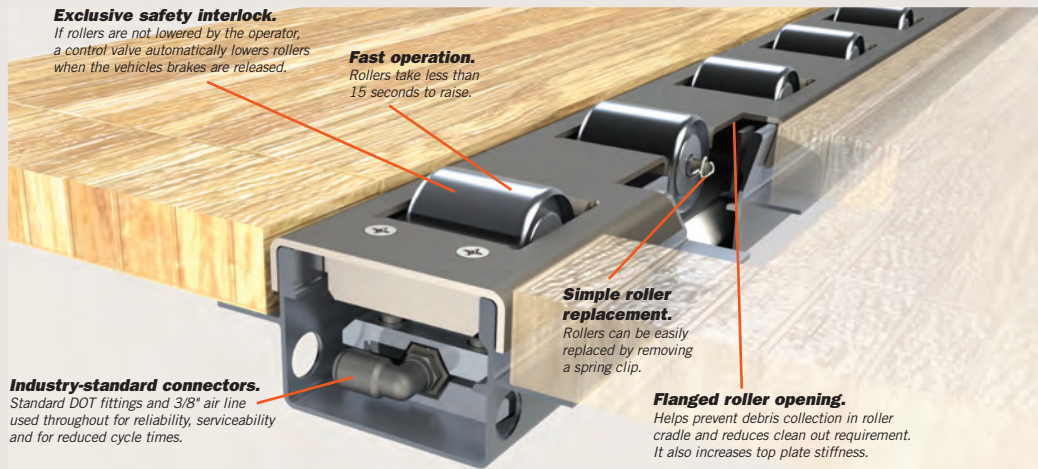

2" ROLLER CONFIGURATIONS

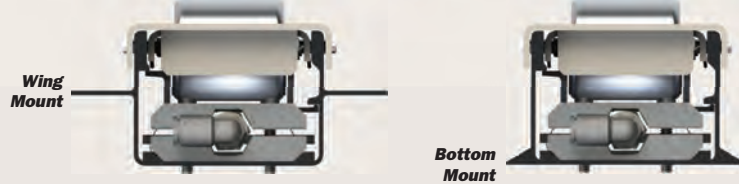

Retract-A-Roll 4

Skate wheels have sealed bearings and 300 lb/ft (136 kg) per dual skate wheel.

The high-capacity skate wheels have lower rolling resistance and longer lifespan. A 5-lane system will do the same work as a 6-lane Retract-A-Roll 2 system.

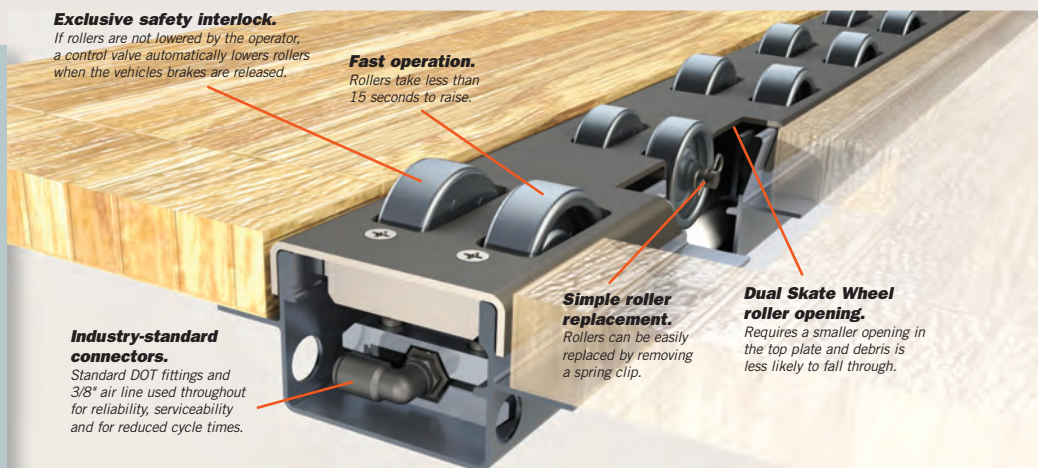

SKATE WHEEL CONFIGURATIONS

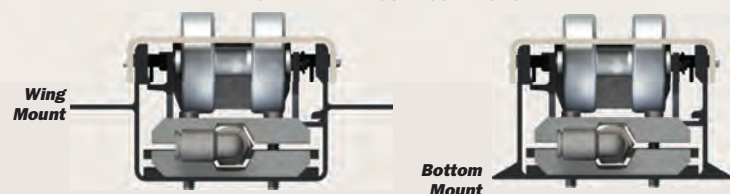

THE RIGHT TRACK

Ankra Series E, A and F Track were designed to team with Ankra end fittings, Beam Sockets, and Decking/Shoring Beams for the strongest, most reliable support. Constructed of steel or aluminum and available in 10' lengths as standard, other lengths available upon request. To withstand corrosion, Ankra galvanized track has a G-90 hot dip finish with a surface chemical treatment. Painted track is finished with either high-quality, powder coat or semi-gloss enamel. Custom lengths and special finishes available, contact Customer Service Department.

Reference TTMA RP No. 47 for installation. Attach track using screws, rivets or by welding. Contact vehicle manufacturer or qualified installer to determine fastener size and mounting method. WARNING: Welding of galvanized material may emit toxic fumes. Please use caution and proper ventilation.

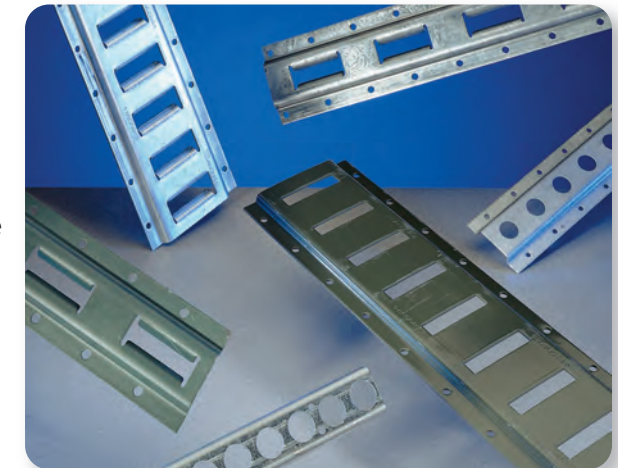

LOGISTIC TRACK

Series E

Series E track is made of high strength 12-gauge steel for Series E end fittings, Beam Sockets and Decking/Shoring Beams.

HORIZONTAL

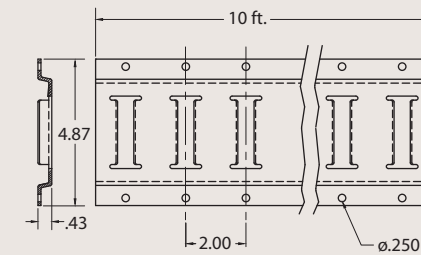
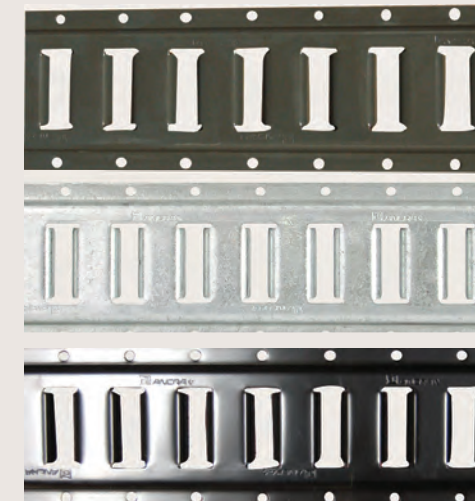

48117-25-120.00
Gray Powdercoat. Weight/Length: 16.6 lbs./10 ft. 7.5 kg./3 m

48117-25-60.00
Gray Powdercoat. Weight/Length: 8.3 lbs./5 ft. 3.77 kg./1.5 m

48117-21-120.00
Galvanized. Weight/Length: 17.2 lbs./10 ft., 7.80 kg./3 m

48117-21-60.00
Galvanized. Weight/Length: 8.6 lbs./5 ft. 3.90 kg./1.5 m

48117-32-120.00
Black Powdercoat Weight/Length: 16.6 lbs./10 ft., 7.5 kg./3 m

VERTICAL

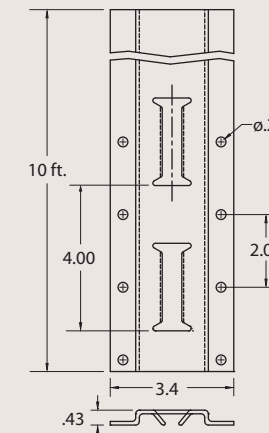

40838-10
Gray Powdercoat.
Weight/Length: 13.5 lbs./10 ft.
6.1 kg./3 m

40838-11
Galvanized.
Weight/Length: 14 lbs./10 ft.
6.4 kg./3 m

LOGISTIC TRACK

Series A Series A track, made of high strength steel or 6061 T6 aluminum, is designed for Series E end fittings, Beam Sockets and Decking/Shoring Beams.

HORIZONTAL

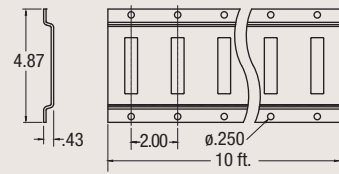

42948-10
Gray Powdercoat.
Weight/Length: 15.0 lbs./10 ft.,
6.8 kg./3 m. 12-gauge.

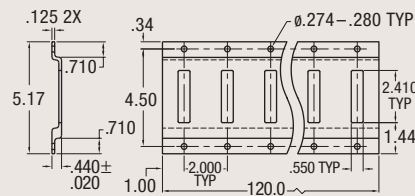

49359-10
Aluminum.
Weight/Length: 8 lbs./10 ft.,
3.6 kg./3 m.

SERIES E & A TRACK END CAPS

Designed to be used with either series E or A track to close the track end which would otherwise be exposed, allowing cargo to get snagged on open edges. Beveled edge of the plastic end caps eliminates any tearing or snagging when loading cargo against the trailer wall. Simply place end caps against the edges of either E or A Track and secure.

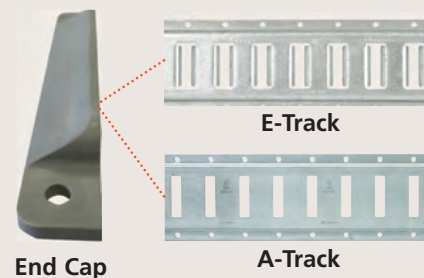

End Cap

A-Track

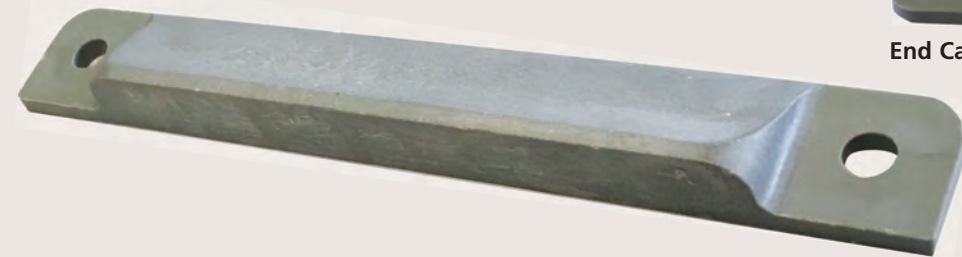

46006-11
Series E & A Track
End Caps
Size: 5.17" w x .73" h

Series F Series F track is made of high strength steel for F end fittings and Shoring Beams.

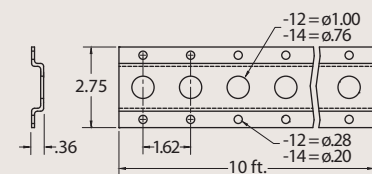
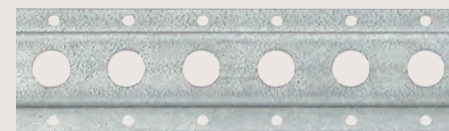

40849-12
Galvanized. 1.62 in. hole spacing &
1" hole dia. (Canada) Weight/length:
6.0 lbs./10 ft., 2.7 kg./3 m. 14-gauge.

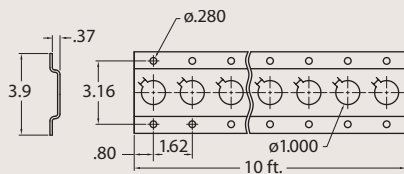

40849-14
Galvanized. 1.62 in. hole spacing &
3/4" hole dia. (USA) Weight/length:
6.0 lbs./10 ft., 2.7 kg./3 m. 15-gauge.

49313-13
Galvanized. 1.62 in. hole spacing &
1" hole dia. (Canada) Weight/length:
12.2 lbs./10 ft., 5.53 kg./3 m.
12-gauge.

LOGISTIC TRACK

Tether Track

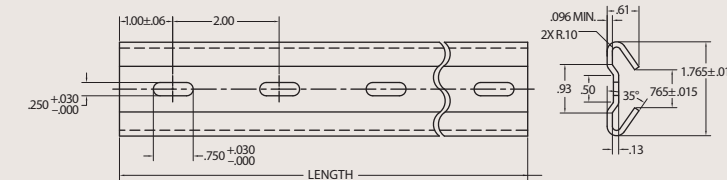

310R-120 **NEW**
Galvanized Steel Tether Track.
Weight/Length: 13.4 lbs./10ft., 6.0 kg/3 m.
Various lengths available.

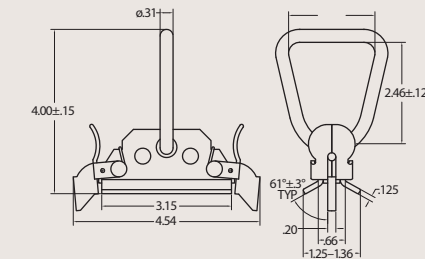

50149-10-310RS **NEW**
Captive Tether Fitting used for the 310R Track.
WLL: 1,000 lbs./453.5 kg.

Series F Channel

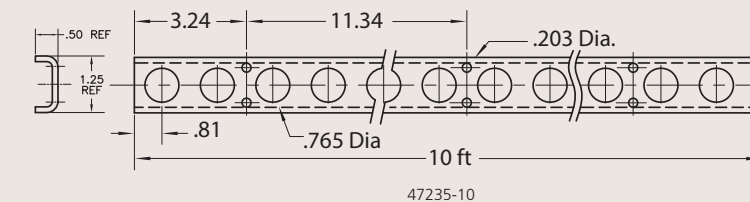

47235-10
Galvanized. 1.62 in. hole spacing & .765" hole diameter.
Weight/Length: 9.0 lbs./10 ft., 4.05 kg./3 m.

BEAMS, BARS & HOOPS

All the innovation and selection you'll ever need. Ankra gives you a choice of shoring beams with steel, aluminum, or heavy-duty aluminum models. Aluminum beams feature a patented flat latch mechanism that eliminates the age old problem of damaged trigger mechanisms. It's easier to release, even while wearing gloves. There is even a replacement flat latch channel assembly that can be used to update your existing beams. Extend beam life and keep your costs low.

ANCR A BEAMS ARE PROUDLY MADE IN USA

STANDARD-DUTY ALUMINUM SERIES E AND A DECKING/SHORING BEAM WITH PATENTED FLAT LATCH

Decking and Shoring WLL: 2,200 lbs./999 kg.*

PATENTED

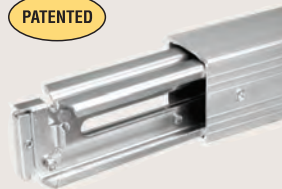

43638-50

Adjustable Range/Weight:
84.7 – 95.6 in./16.0 lbs./7.3 kg.

43638-51

Adjustable Range/Weight:
92.9 – 103.8/18.8 lbs./8.5 kg.

WIDE TOP ALUMINUM SERIES E AND A DECKING BEAM WITH PATENTED FLAT LATCH

Decking WLL: 3000 lbs./1363 kg*

PATENTED

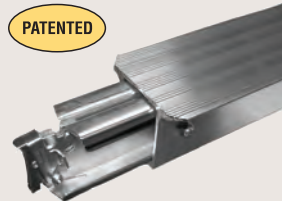

50158-10

Wide Top Decking Beam with textured, 4-1/2" top surface to increase contact area for cargo on the beam deck. Adjustable Range/Weight: 92.9-103.8 in./26.4 lbs./12.0 kg. Decking WLL: 3,000 lbs. not recommended for shoring. Patented Flat Latch.

HEAVY-DUTY ALUMINUM SERIES E AND A BEAM ASSEMBLY WITH PATENTED FLAT LATCH

Decking WLL: 3,000 lbs./1,363 kg.* Shoring WLL: 2,500 lbs./1,136 kg.*

PATENTED

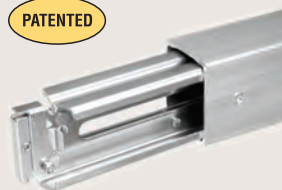

49039-50

Adjustable Range/Weight:
84.7 – 95.6/
20.5 lbs./9.3 kg.

49039-51

Adjustable Range/Weight:
92.9 – 103.8/
22.5 lbs./10.2 kg.

49039-52

Adjustable Range/Weight:
96.0 – 106.9/
24.5 lbs./11.0 kg.

SERIES E AND A STEEL DECKING/SHORING BEAM WITH TRIGGER LATCH

Decking WLL: 2,000 lbs./900 kg. Shoring WLL: 1,100 lbs./499 kg.*



49360-13

Adjustable Range/Weight: 92.1 – 102.9 in./27 lbs./12.3 kg. 14 gauge steel.
Decking WLL: 2,000 lbs./907 kg.

DECKING BEAM HOOPS

47670-10

Designed to help restrain the movement of packages of cargo within your truck or trailer. Two hoops and attachment hardware are included providing easy mounting. For 43638, 49039 and 49360 series E and A Decking/Shoring Beams. Weight: 13.25 lbs./6.01 kg.

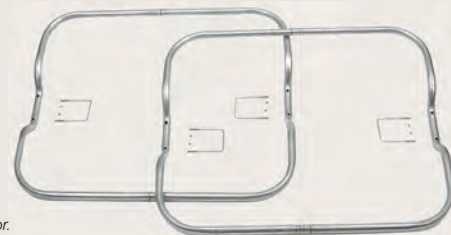

*Working Load Limit (WLL) rating is 1/3 of breaking strength with evenly distributed load. Never exceed trailer manufacturer decking load limits. Do not create an unstable, top heavy trailer. Load heavier items on trailer floor.

BEAMS, BARS & HOOPS

REPLACEMENT PARTS

PATENTED



43627-13

Replacement Channel Assembly with patented flat latch. 11 Gauge. Weight: 3.8 lbs./1.73 kg. For aluminum beams 43638, 49039 and 50158. Can be retrofitted into conventional trigger style beams.



50194-100

Low Profile Allen Sleeve Nut and Bolt Kit. Low profile allen head bolt and sleeve nut with a semi-flush head height of .10". Used for attaching channel assemblies to beams. The bolt has a self locking patch to prevent loosening due to vibration. For 43638, 49039, 49360, 49414, 50080, 50158, 50186, 50191 and 50420 beams. Weight: .10 lb./5 kg.

PATENTED



45951-12

Flat Latch Repair Kit Includes latch, screw, nut, springs and instructions. Weight: .14 lb./06 kg. For Part No. 43627-13 channel assembly.

BEAM SOCKETS — For use with standard commercial grade Douglas Fir 2-in. x 6-in. lumber.

PLEASE NOTE: The working load limit of lumber varies widely.



40921-10

Standard Beam Socket. Weight: .70 lb./32 kg.



40921-11

Heavy-Duty Beam Socket. Internally welded plate for added strength. Weight: .85 lb./39 kg.

SHORING BARS – F SERIES WITH NEW EASY PUSH BUTTON DESIGN



49439-10

Round Shoring Bar. Steel. Adjustable in 2" increments to 117". Weight: 20.0 lbs./9.1 kg. Shoring WLL: 500 lbs./227 kg. Recommended installed length: 81" – 117". Outer tube diameter: 1.66" Inner tube diameter: .72" 3/4" hole dia. (USA)

49439-11

Round Shoring Bar. Steel. Adjustable in 2" increments to 117". Weight: 20.0 lbs./9.1 kg. Shoring WLL: 500 lbs./227 kg. Recommended installed length: 81" – 117". Outer tube diameter: 1.66" Inner tube diameter: .945" 1" hole dia. (Canada)



49439-20

Square Shoring Bar. Steel. Adjustable in 2" increments to 117". Weight: 28.0 lbs./12.71 kg. Shoring WLL: 1,000 lbs./454 kg. Recommended installed length: 81" – 117". Tube size 2" square. Inner tube diameter: .72" 3/4" hole dia. (USA)

49439-21

Square Shoring Bar. Steel. Adjustable in 2" increments to 117". Weight: 28.0 lbs./12.71 kg. Shoring WLL: 1,000 lbs./454 kg. Recommended installed length: 81" – 117". Tube size 2" square. Inner tube diameter: .945" 1" hole dia. (Canada)

*Working Load Limit (WLL) rating is 1/3 of breaking strength with an evenly distributed load.

CARGO STA® BARS & HOOP SET

ALUMINUM STANDARD CARGO STA®



43782-15 6061 T6 Aluminum
Length/Weight: 89.75 – 104.5 in. 8.95 lbs./4.07 kg.
Long Tube Diameter: 1.50 in.

ECONOMY CARGO STA® II

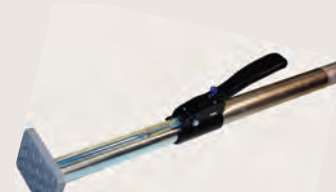

NEW 50441-10 Cargo Sta® II
Affordable Security. Ancra's new Cargo Sta® II features bolt-on feet and a recessed gear rack, which prevents a pinch point while providing a smooth exterior surface for less potential cargo damage. Its release handle is located on the handle and not the housing, ensuring easy operation.

- ▶ Extension range: 89.75" to 104.5"
- ▶ Weight: 10.23 lbs./4.64 kg.
- ▶ Black powder coated handle and housing

STEEL CARGO STA®



48407-10 Galvanized Steel Tubing
Length/Weight: 89.75 – 104.5 in. 11.72 lbs./5.33 kg.
Long Tube Diameter: 1.50 in.

CARGO STA® AND JACK BAR REPLACEMENTS

43781-15S
2 in. x 4 in. Bolt-on.
Weight: .78 lb./.36 kg.
For 43782-15, 48407-10.



Foot, Adjustable End (short)

43781-14S
2 in. x 4 in. Bolt-on.
Weight: .62 lb./.29 kg.
For 43782-15, 48407-10.



Foot, Fixed End (long)

43781-17
4 in. x 4 in. Bolt-on.
Weight: 1.35 lbs./.61 kg.
For 49205-25, 49205-26,
49205-27, 49205-28, 49205-31.

43781-16
4 in. x 4 in. Bolt-on.
Weight: 1.1 lbs./.5 kg.
For 49205-25, 49205-26,
49205-27, 49205-28, 49205-31.

HOOP SET FOR CARGO STA®

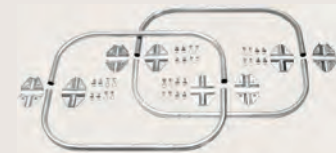

43991-10
Designed to help restrain the movement of small packages of cargo within your truck or trailer. Two hoops and attachment hardware are included providing easy mounting. For 43782, 48407 round tube bars. Tube Diameter: 1.5 in.
Weight: 10.0 lbs./4.5 kg.



49443-10 Housing, Rack and Lever Assembly
For Cargo Sta 43782-15, 48407-10.
Complete with necessary hardware.
Weight: 2.12 lbs./.97 kg.



49400-10 38" Red Handle Assembly

49400-11 28" Black Handle Assembly

Jack Bar Component Kits
Complete kit consisting of a Jack Assembly Housing, 4" x 4" adjustable end foot, 4" x 4" fixed end foot and all necessary hardware.
49400-10 Red Handle for 49205-26, 49205-27 & 49205-31 Jack Bars.
49400-11 Black Handle for 49205-25 & 49205-28 Jack Bars.

HEAVY-DUTY JACK BARS

Jack Bars feature 4" x 4" bolt-on feet assemblies and are designed for use in general duty cargo applications. They feature 1-1/2" square heavy-gauge, galvanized steel tubing with a cycle tested, heavy duty automotive jack assembly. The jack mechanism includes a quick release feature that allows the bar to be quickly retracted for easy removal. For ease of recognition, bars with the longest adjustment range have red handles.

HEAVY-DUTY ONE-PIECE GALVANIZED

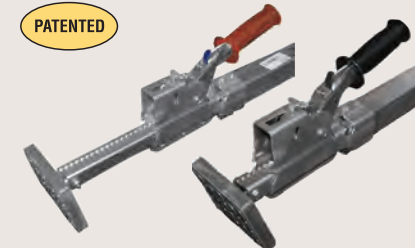

PATENTED



49205-25 Weight: 16.2 lbs./7.35 kg. Adjustment range: 85.0" – 104.0" Black Handle
49205-26 Weight: 16.6 lbs./7.54 kg. Adjustment range: 85.0" – 114.0" Red Handle

HEAVY-DUTY ONE-PIECE GALVANIZED WITH HOOPS

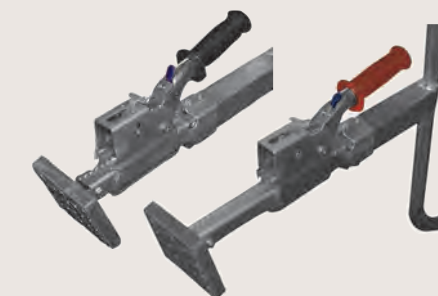

49205-27 Weight: 20.0 lbs./9.08 kg. Adjustment range: 85.0" – 114.0" Red Handle
49205-28 Weight: 19.6 lbs./9.0 kg. Adjustment range: 85.0" – 104.0" Black Handle

UNIVERSAL JACK BAR

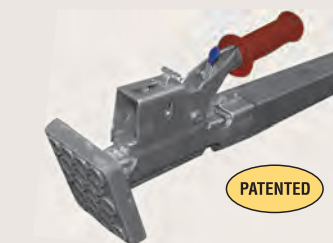

PATENTED

49205-31
Weight: 18.2 lbs./8.26 kg.

- 51" size used to restrain half loads; compact to fit in locked tool box
- Useful in various load configurations through the universal design
- Patented Safety Snap Pin



Fully Retracted

Adjustment Range: 51" – 80"

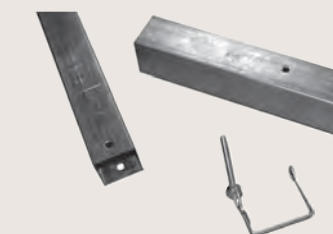

Mid Extension

Adjustment Range: 70" – 99"



Full Extension

Adjustment Range: 85" – 114"

CAUTION:

Due to variations in trailer wall construction, Cargo Sta® and Jack Bars do not have rated Working Load Limits. Read and follow instructions on bar labels.

ACCESSORIES

BAR KEEP™ CARGO BAR HOLDER

Constructed of high quality steel and finished with black powder coating for corrosion resistance. Holds two standard or heavy-duty cargo bars. A built in gasket reduces vibration and rattle while protecting the bars. Accommodates both 2" x 4" or 4" x 4" feet.



49348-11 Weight: 6.68 lbs./3.03 kg.



ANCRA BEAM RACK

PATENTED

The Ankra Beam Rack is designed to allow for quick and easy storage of beams in your trailer. These patented beam holders fit easily into your existing logistics posts to provide a secure method of raising your beams up and out of the way when not in use. The unique design lets you lock in up to 6 beams per set horizontally in your trailer.

NEW 50410-12 Weight: 4 lbs./3.03 kg.

DOOR PULL STRAPS

For pulling overhead, and side doors and wheel carts. Rust protected galvanized steel clip is pre-punched for easy installation.



- 49015-18** 18-in. Door Pull Strap. Weight: .20 lb./0.09 kg.
- 49015-24** 24-in. Door Pull Strap. Weight: .30 lb./0.14 kg.
- 49015-36** 36-in. Door Pull Strap. Weight: .40 lb./0.18 kg.

10788-10 Door Pull Strap. WLL: 500 lbs./227 kg Weight: 1.6 lbs./0.72 kg

Allows the driver to close the roll-up door while standing on the ground.

- ▶ Black wear sleeve protects the elastic section
- ▶ Easily installs into existing logistics post or E track of the sidewall and the inside of the rear roll up door.



TIE OFFS A convenient way to attach rope or web to trailer side wall.



40386-10
Series E and A Rope Tie Off 3-piece end fitting for use with Series E or A Track. WLL: 1,000 lbs./454 kg. Weight: .30 lb./0.14 kg.



40386-12
Series F Rope Tie Off. For use with Series F Track USA. WLL: 500 lbs./225 kg. Weight: .30 lb./0.14 kg.
40386-13
For use with Series F Track Canada. WLL: 500 lbs./225 kg. Weight: .30 lb./0.14 kg.

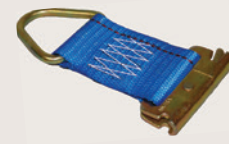

40386-11
Series E and A Rope Tie Off Spring actuated fitting for use with Series E or Series A Track. WLL: 1,333 lbs./605 kg. Weight: .40 lbs./0.18 kg.



49542-10
Series E and A Fitting w/ D-Ring. WLL: 1,000 lbs./454 kg. Weight: .34 lb./0.15 kg.



47772-12
Series E and A Track Fitting w/ Round Ring. WLL: 1,000 lbs./454 kg. Weight: .45 lb./0.20 kg.



50115-10
Heavy-Duty Series E and A Track Fitting w/ Round Ring. Heat treated. WLL: 2,000 lbs./908 kg. Weight: .40 lbs./0.18 kg.



50115-11
Heavy-Duty Series E and A Track Fitting w/ D-Ring. Heat treated. WLL: 2,000 lbs./908 kg. Weight: .40 lbs./0.18 kg.

ACCESSORIES

TRUCK & TRAILER FITTINGS

Designed for low-profile mounting in trucks and trailers, the Recessed Pan Fitting is tensioned to reduce ring movement, but allows easy lifting. The Stake Pocket Anchor can be surface or flush mounted and accepts roll cart lock pins.



45545-15
With black trim collar. WLL: 530 lbs./240 kg. Weight: .30 lb./0.14 kg.

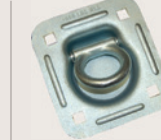

45849-15
Recessed Pan Fitting WLL: 1,666 lbs./757 kg. Weight: 1.20 lbs./0.55 kg.



49371-10
Stake Pocket Anchor. Conforms to USPS drawing B-13956. Black Lacquer Finish. Weight: 0.98 lb./0.44 kg.



TRANSMAT® FRICTION MAT

49382-10 Durable 2mm-thick, 30" x 42" rubber mats offer stability to any load and reduce risk of load shifting in box cars or intermodal transport.

- ▶ Coefficient of friction of 1.2 minimum
- ▶ Shore A hardness of 35-55
- ▶ Meets new minimum 1g loading regulations

TRAILER DOOR LIMIT STRAP

10924-10 Designed to be used when opening swing doors.

- ▶ If cargo has shifted against the doors during transit, they may swing open suddenly when the lock bar is released, dumping cargo out of the trailer and causing injury
- ▶ The hooks are inserted into the lock tabs on each door before opening to limit the motion of the door
- ▶ 800 lbs./363 kg. WLL hook with keeper
- ▶ 32-inch length from hook to hook

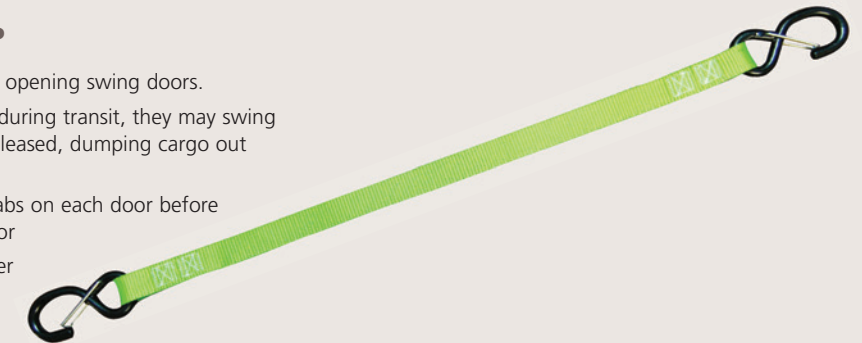

NEW DRIVER ASSIST STRAPS



Helping Hand. Ancra's Driver Assist Straps lend a hand to drivers and dock workers climbing into and out of trailers. The 36-inch strap with a reinforced 12-inch loop handle connects to existing E or A track, offering a convenient handgrip for a more secure entry and exit. Now available with two hand loops for added stability, the straps are assembled with high strength components for a rated user weight limit of 320 lbs.

10902-11 Single Loop **10902-11PK** (Retail Packaged)



PATENTED



10902-21 Dual Loop



ACCESSORIES

NEW TRAILER ACCESS STEPS

Step up! If your truck or van trailer has a 48-inch deck height, Ancra's new Trailer Access Steps will give you a boost. Available in 2- or 3-steps, the galvanized steps self-latch for stowing, and extend smoothly from a stored position.

Weight limit: 350 lbs. Easily bolt or weld to cross members under the trailer floor.

Ancra Installation Kit (50456-Kit) sold separately for mounting. Includes two 3" wide formed steel bars with mounting holes for the steps and cross member clamps, bolts and lock nuts with flat washers. Installation manual included.

PATENT PENDING

2-Step Galvanized

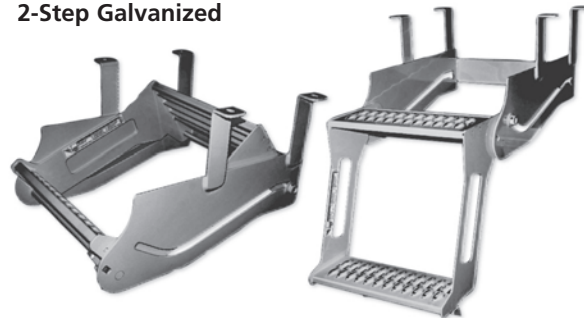

50456-2-GALV Trailer Access Steps. 2-Step Galvanized.

3-Step Galvanized

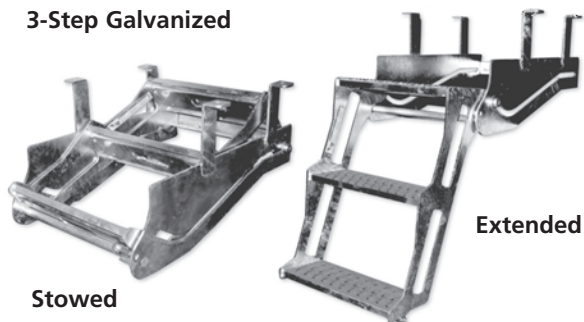

Stowed

50456-3-GALV Trailer Access Steps. 3-Step Galvanized.



50456-KIT Trailer Access Steps Installation Kit



Extended on Truck



Stowed on Truck

TENSION-LIMITING RATCHET ASSEMBLIES

No more overtightening

You can prevent damage caused by over tightened ratchet buckles with the Tension-Limiting Ratchet Buckle. Ancra's innovative buckle will tighten to no more than 300 pounds of tension. It's enough force to secure the cargo, but not enough to damage your vehicle. Not even your strongest driver can apply too much force.

How it works

Once the strap is installed in the track, ratchet the strap normally. When proper tension is reached, the handle releases and no more tension can be applied. Even if you try, you can never go too tight. Assemblies are available with Low Profile or Heavy-Duty long handle buckles. There are six Torque-Limiting Ratchet Straps available in lengths from 12 to 20 feet.



Series E Heavy-Duty Buckle Strap w/ Spring E Fitting
Heavy-duty 12,000 lbs. yellow latex treated polyester webbing.
WLL: 1,333 lbs./605 kg. Fixed End: 48-in.

Part No.	Strap Length	Weight
49021-30	12 ft.	4.00 lbs.
49021-31	16 ft.	4.25 lbs.
49021-32	20 ft.	4.50 lbs.



Series E Low Profile Buckle Strap w/ Spring E Fitting
Strong 6,000 lbs. polyester webbing.
WLL: 1,333 lbs./605 kg. Fixed End: 48-in.

Part No.	Strap Length	Weight
48672-33	12 ft.	2.50 lbs.
48672-34	16 ft.	2.65 lbs.
48672-35	20 ft.	2.80 lbs.

LOGISTIC STRAPS & ASSEMBLIES

Ancra logistic straps are available in cam buckle and ratchet buckle models with end hardware to suit your specific application. Made with strong polyester webbing, they are color coded to easily identify the length. The standard fixed end length for all straps is 48". Built on a reputation for dependability and strength, these strap assemblies promise the quality that comes with every product that bears the Ancra name.



CAM BUCKLE STRAP ASSEMBLIES

6,000 lb. Polyester Webbing (47200) with a Cam Buckle (40880-15). The adjustable end of the straps are captivated to prevent them from pulling out of the buckle and separating.

SERIES E STRAP ASSEMBLY Working Load Limit: 833 lbs./378 kg.



Series E Assembly with spring actuated end fitting

Part No.	Strap Length	Weight
40602-17	12 ft.	1.65 lbs.
40602-18	16 ft.	1.80 lbs.
40602-19	20 ft.	1.95 lbs.

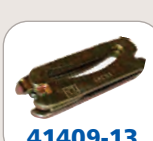

Series E Assembly with 3-piece end fitting

Part No.	Strap Length	Weight
40602-10	12 ft.	1.55 lbs.
40602-11	16 ft.	1.70 lbs.
40602-12	20 ft.	1.85 lbs.

SERIES F STRAP ASSEMBLY (USA) Working Load Limit: 500 lbs./225 kg.



For use with USA type 3/4" dia. hole F track

Part No.	Strap Length	Weight
40602-20	12 ft.	2.40 lbs.
40602-21	16 ft.	2.55 lbs.
40602-22	20 ft.	2.70 lbs.

SERIES F STRAP ASSEMBLY (CANADA) Working Load Limit: 500 lbs./225 kg.



For use with Canada type 1" dia. hole F track

Part No.	Strap Length	Weight
40602-103	12 ft.	2.40 lbs.
40602-104	16 ft.	2.55 lbs.
40602-105	20 ft.	2.70 lbs.

Please note: Ancra logistics straps come in three webbing colors, coded according to lengths. 12 ft. webbing is yellow, 16 ft. webbing is grey, 20 ft. webbing is blue. End fitting part numbers are shown for reference only.

CAM BUCKLE STRAP ASSEMBLIES

ELECTRONIC STRAP ASSEMBLY Working Load Limit: 833 lbs./378 kg. Fixed Ends: 7-in. & 48-in. 6,000 lbs. polyester webbing 47200 and cam buckle 40880-19. Fixed End: 48-in.



Part No.	Strap Length	Weight
49025-20	12 ft.	1.90 lbs.
49025-21	16 ft.	2.05 lbs.
49025-22	20 ft.	2.20 lbs.

An additional E fitting allows for increased adjustability for various applications.

PLATE TRAILER STRAPS 6,000 lbs. polyester webbing 47200 and cam buckle 40880-19.

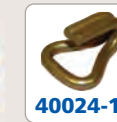

Part No.	Strap Length	Weight
48253-19	12 ft.	1.85 lbs.
48253-20	16 ft.	2.00 lbs.
48253-21	20 ft.	2.15 lbs.

Cam Buckle Strap w/ Wire Hook & Spring E Fitting
WLL: 833 lbs./378 kg.

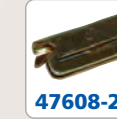

Part No.	Strap Length	Weight
48253-22	12ft.	2.00 lbs.
48253-23	16 ft.	2.15 lbs.
48253-24	20 ft.	2.30 lbs.

Cam Buckle Strap w/ F Hook & Spring E Fitting. Fixed End: 48-in.
WLL: 800 lbs./360 kg.

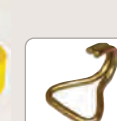
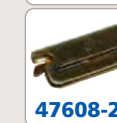

Part No.	Strap Length	Weight
40602-97	12ft.	1.50 lbs.
40602-98	16 ft.	1.65 lbs.
40602-99	20 ft.	1.80 lbs.

Cam Buckle Strap w/ Wire Hooks. Fixed End: 48-in.
WLL: 500 lbs./225 kg.

RATCHET BUCKLE STRAP ASSEMBLIES

RATCHET BUCKLE STRAPS Working Load Limit: 1,333 lbs./605 kg. Fixed End: 48-in.



6,000 lb. polyester webbing 47200 and low profile ratchet buckle 44258-13 for durability and wear.

Part No.	Strap Length	Weight
48672-13	12 ft.	2.25 lbs.
48672-14	16 ft.	2.40 lbs.
48672-15	20 ft.	2.55 lbs.

Series E Ratchet Buckle Strap w/ 47608-21 Spring End Fitting



Heavy-duty 12,000 lb. yellow polyester webbing 41632-13 and standard handle ratchet buckle 44627-11 for durability and wear. All yellow straps.

Part No.	Strap Length	Weight
49021-20	12 ft.	3.50 lbs.
49021-21	16 ft.	3.75 lbs.
49021-22	20 ft.	4.00 lbs.

Series E Heavy-Duty Ratchet Buckle Strap w/ 47608-21 Spring End Fitting
WLL: 1,333 lbs./605 kg. Fixed End: 48-in.

PLATE TRAILER STRAPS 6,000 lbs. polyester webbing 47200 and low profile ratchet buckle 44258-13. Fixed End: 48-in.

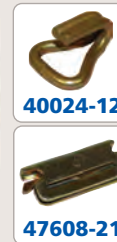

Part No.	Strap Length	Weight
48253-13	12 ft.	2.50 lbs.
48253-14	16 ft.	2.65 lbs.
48253-15	20 ft.	2.80 lbs.

Ratchet Buckle Strap w/ Wire Hook & Spring E Fitting
WLL: 833 lbs./378 kg.

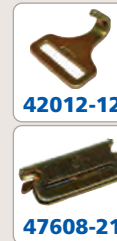

Part No.	Strap Length	Weight
48253-16	12 ft.	2.70 lbs.
48253-17	16 ft.	2.85 lbs.
48253-18	20 ft.	3.00 lbs.

Ratchet Buckle Strap w/ F Hook & Spring E Fitting
WLL: 800 lbs./360 kg.

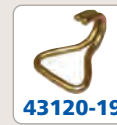

Part No.	Strap Length	Weight
48672-22	12 ft.	2.00 lbs.
48672-23	16 ft.	2.15 lbs.
48672-24	20 ft.	2.30 lbs.

Ratchet Buckle Strap w/ Wire Hooks
WLL: 500 lbs./225 kg.

TIE DOWN STRAPS & ASSEMBLIES

CUSTOM NETS

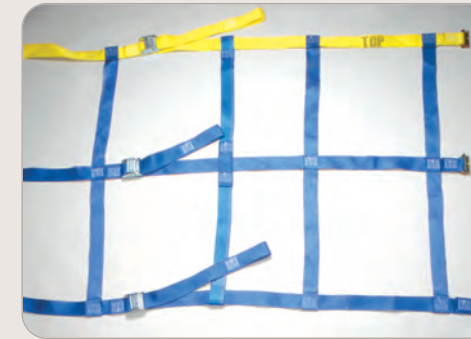

Ancra custom solutions promise quality and performance.

Designed for your particular application, Ancra custom nets offer retention support for various sized and shaped packages. Using strong 1" or 2" webbing, they're individually tailored to fit your loading condition, assuring maximum effectiveness in transporting a load securely.

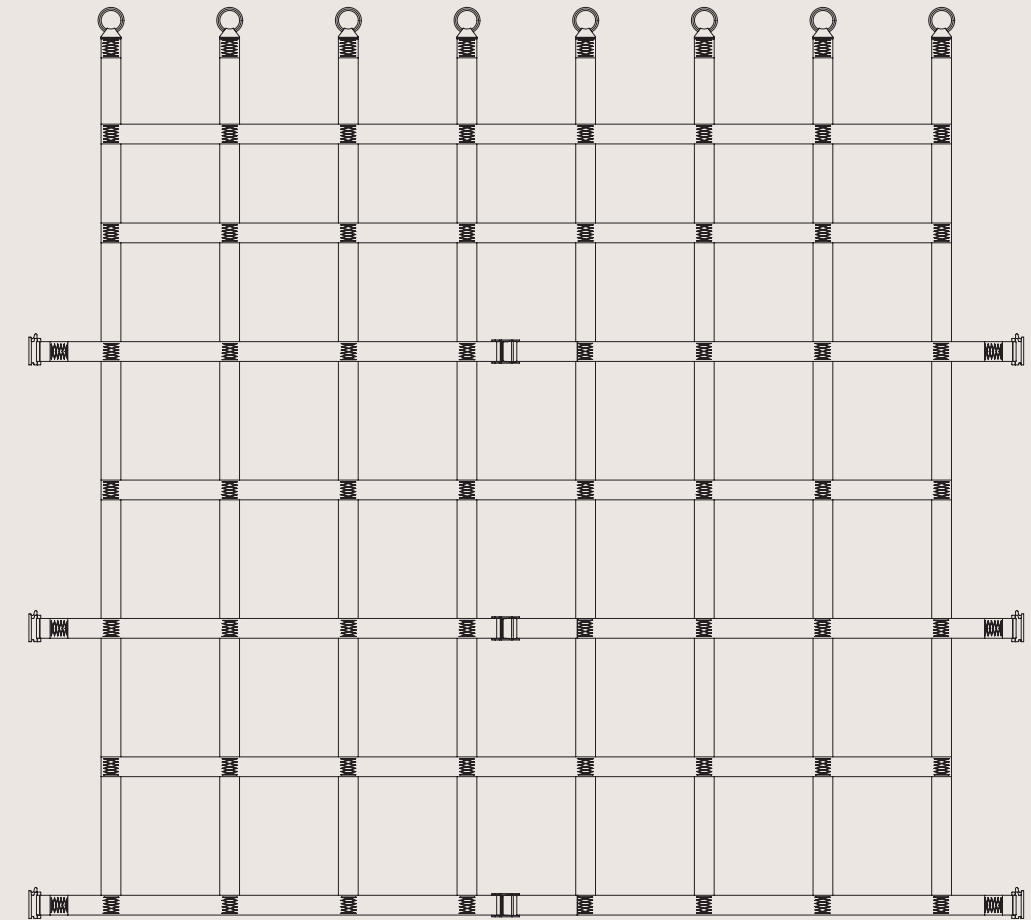

MOBILE APP

NEW Poly Deckboard Calculator

Input Data in Yellow Fields Below		Load Sample Data	Clear Data	Payload Increase	
		Plywood	Poly Deckboard	Per truck/trailer:	Per fleet:
Number of Trucks/Trailers:	100	100		140	14000
Boards Per Truck/Trailer:	20	20		58800	5880000
Costs per board: - volume discounts may apply on PDB cost	\$15.00	\$55.00		Annual increased revenue:	\$147
Maintenance minutes (Sweeping out splinters) Per truck/trailer per day	6	3			\$14700
Maintenance rate-\$/hr:	\$40.00	\$40.00		Per truck/trailer:	\$147
Loads per week per truck/trailer	12	12		Per fleet:	\$14700
Number of weeks per year in operation	50	50		Increase payload-annual:	\$127
Percentage of loads at maximum weight	70%	70%		Board cost savings-annual:	\$1400
Dollars per ton of payload:	\$5.00	\$5.00		Maintenance cost reduction-annual:	\$1674
Weight -lbs	28	21		TOTAL ANNUAL VALUE:	\$167367
Average Service Life-months	12	72			
Initial Investment:	\$30000	\$110000			
Scrap value@ \$3.00 per PDB:	\$0	\$6000			
Annual board expense:	\$30000	\$0			

See how Ancra's Poly Deckboard Calculator can help your fleet maximize ROI.



Like all Ancra products, our line of safety and emergency equipment is engineered with an understanding of your requirements and our ongoing commitment to your safety. Our safety products carry the assurance of dependability. Ancra is known for, offering the best in flags, banners, lights, reflectors and wearables.

- All Ancra flags and banners meet FMCSA 393.87 standards
- Durable, reversible banners are now available with sewn-in bungee cords for convenience and ease of use.
- Emergency lights and reflective warning equipment have been introduced to assist you on the road.
- Our line of wearables include high visibility safety vests and durable, reflective work gloves.



SAFE TRAVELS

Keeping you safe and your cargo secure, Ancra has introduced an extended line of safety and emergency equipment. Our flags, banners, lights, reflectors and wearables complement our existing safety products to bring you more flexibility and convenience while protecting you against hazards on the road.



SAFETY PRODUCTS

Flags & Banners

Meet FMCSA 393.87 standards.



49893-10
Fluorescent Red Heavy-Duty Mesh Flag w/ wooden dowel. 18" x 18"



49893-11
Red Cotton Flag w/ 7 Gauge Wire w/ 1/2" loop. 18" x 18"



49893-12
Fluorescent Red Mesh Flag w/ 2 brass grommets. 18" x 18"



49893-13
Fluorescent Orange Mesh Flag w/ wooden dowel. 18" x 18"



49893-14
Fluorescent Orange Mesh Flag w/ 2 brass grommets. 18" x 18"



NEW 49893-15
Red Cotton Flag w/ 3/4" x 30" wooden dowel. 18" x 18"



NEW 49893-16
Red Jersey Mesh Flag w/ 3/4" x 30" wooden dowel. 18" x 18"



NEW 49893-17
Red Jersey Mesh Flag w/ 7 Gauge Wire w/ 1/2" loop. 18" x 18"



NEW 49893-18
Fluorescent Orange Mesh Flag w/ 7 Gauge Wire w/ 1/2" loop. 18" x 18"



NEW 49893-19
Orange Jersey Mesh Flag w/ 7 Gauge Wire w/ 1/2" loop. 18" x 18"



NEW 49893-20
Orange Cotton Fabric Flag w/ 2 brass grommets. 18" x 18"



NEW 50430-10
Magnetic Flag Holder
Secure warning flags with 2.3" diameter ceramic magnet rated at 80-lb. pull force. Holder has center screw and wing nut for flag attachment. Nylon insert prevents wing nut from backing off during transport.

SAFETY PRODUCTS

Flags & Banners



49894-10
Double-sided banner reads WIDE LOAD and OVERSIZED LOAD. Made of durable vinyl fabric and comes with six grommets and four 44" attachment ropes. 84" x 18" Tri-lingual package.



49894-11
Double-sided banner reads WIDE LOAD and OVERSIZED LOAD. Made of durable vinyl fabric and comes with sewn-in ropes top and bottom, plus six grommets. 84" x 18" Tri-lingual package.



49894-12
Double-sided banner reads WIDE LOAD and OVERSIZED LOAD. Made of durable vinyl fabric and comes with six grommets and four 44" attachment ropes. 72" x 14" Tri-lingual package.



49894-13
Mesh OVERSIZED LOAD banner. Made of woven polyester mesh with six grommets and four 44" attachment ropes. 84" x 18" Tri-lingual package.



49894-14
Mesh WIDE LOAD banner. Made of woven polyester mesh with six grommets and four 44" attachment ropes. 84" x 18" Tri-lingual package.

NEW 49894-15
OVERSIZED LOAD and WIDE LOAD reversible banners with sewn-in bungee cords to eliminate the need for additional ropes or cords to attach banner. 6 grommets, 84" x 18"



Canada D Signs



49895-10
Canadian D sign is made of durable vinyl fabric. Comes with 10 grommet attachment points. 96" x 12"

REFLECTIVE SIGNS



49895-11
Reflective Canadian D Sign with 10 grommets. 96" x 12"

49895-12
Reflective Canadian D Sign with 10 grommets. 96" x 18"

49895-13
Reflective Canadian D Sign with 10 grommets, reverse side: Oversize Load. 96" x 18"

EMERGENCY EQUIPMENT

Lights & Reflectors



NEW 50440-10

HELP Light Kit – 3 puck-style rain-proof lights w/ storage bag

- ▶ 15 high output LEDs (12 red, 3 white)
- ▶ 360° visibility for up to one mile
- ▶ Three modes: red LEDs on steady (5 hours battery life), red LEDs double pulse (9 hours), white LEDs on steady (6 hours)
- ▶ Impact-resistant plastic in safety yellow
- ▶ Runs on 3 AAA batteries (included)
- ▶ Magnet and folding hook on back



NEW 50437-10PK

LED Flashlight

Durable, rain-resistant, anodized aluminum case flashlight with 400-lumen output and 200-meter range.

- ▶ Zoom in and out size of light beam by moving the barrel
- ▶ 2-hour battery runtime
- ▶ Blue on-off tactical type tail switch



NEW 50434-10

Triangle Warning Kit

Certified by AMECA and DOT and in compliance with FMCSA standards, Ancra's 3 collapsible reflective triangles come in a durable red plastic carrying case. Includes trilingual set-up and proper usage instructions to be in compliance with FMCSA.

Wearables

NEW

High Visibility 5-Point Tear-Away Safety Vest

One-size-fits-most safety vest with 5-point tear-away hook and loop fastener side, shoulder and front closures.

Available in Lime Green and Orange. Compliant with CSA Z96-15 Class 2, Level 1 & ANSI/ISEA 107-2015 Type R, Class 2.



50532-12 Lime Green



50532-13 Orange



NEW

**50435-L
50435-XL**

Reflective Work Gloves w/split leather palm and fingers

Two sizes Large and XL work gloves with breathable, high-visibility cloth back and retro-reflective strips.



NEW

**50435-3T-L
50435-3T-XL**

Insulated Reflective Work Gloves

Fully lined with 3M Thinsulate, gloves with high visibility cloth back and retro-reflective strips are available in Large and XL.



Whether transporting a load of cars or someone's pride and joy, you depend on proven quality restraint products. Ancra designs and manufactures auto transport products, strap assemblies, harnesses and hardware to meet your most demanding requirements. We're committed to offering you the quality you demand.

TIE DOWNS & ACCESSORIES

CAR HAULER RATCHET STRAPS WLL: 3,333 lbs./1,515 kg. using 41632-46 yellow latex treated polyester webbing and 47105-11 Short Wide Handle Ratchet Buckle. Available with 43120-13 Wire Hooks or 49914-11 Low Profile Swivel J Hooks. Straps include 2 rubber tread cleats.



50179-10

2" x 102" Ratchet Strap w/ Wire Hooks. Weight 5 lbs./2.3 kg.

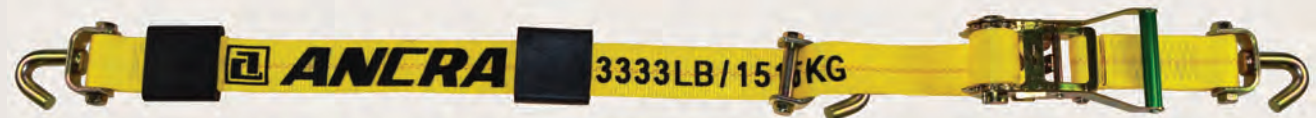

50179-11

2" x 102" Ratchet Strap w/ Low Profile Swivel J Hook. Weight 6.1 lbs./2.8 kg.

AUTO HAULER WINCH STRAP



48487-24

2" x 140" Winch Strap w/ cleats

The auto tie down strap goes over the tire and utilizes three cleated rubber pads that mesh with the tread to keep the strap centered and secured. Weight 1.9 lbs./.86 kg.

SINGLE CLEAT

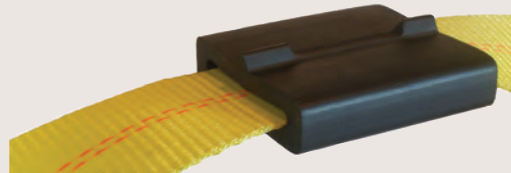

48485-11

Rubber tread cleat for Auto Hauler Winch Strap. Used with 2-inch webbing to secure strap to vehicle tire. Length: 3.0-in. Width: 2.8-in. Weight: .20 lbs./.09 kg.

TIE DOWN W/ SNAP HOOKS Working Load Limit: 1,666 lbs./757 kg. using 41632-13 yellow latex treated polyester webbing, a 47105-11 Short Wide Handle Ratchet Buckle and 40084-14 Snap Hooks.



Part No.	Strap Length	Weight	Fixed End
49020-20	6 ft.	3.80 lbs./1.73 kg.	6 in.
49020-21	8 ft.	4.44 lbs./2.02 kg.	8 in.
49020-22	12 ft.	4.84 lbs./2.20 kg.	12 in.

Ancra's tie downs feature yellow latex treated polyester webbing (41632-13) with Ratchet Buckle (47105-11) and Snap Hook (40084-14).

TIE DOWNS & 'TRANSIT' STRAPS

ANTIQUE & RACE CAR TIE DOWNS



30AS33-BK

2" x 33" Black Axle Strap w/ sleeve. Individually display packaged. WLL: 3,300 lbs./1,498 kg. Weight .5 lbs./23 kg.



500-C8-RD

2" x 8' Red Ratchet Strap w/ Twisted Snap Hooks. WLL: 3,300 lbs. Weight 5 lbs./2.3 kg.

DOLLY STRAPS Ancra designs and manufactures a complete line of wheel straps for automobile-towing dollies. Three of the more popular designs are shown here. Call us about your specific requirements.



BASKET STRAP

45143-20

for tires 7"W x 20"H
Weight: 2.25 lbs./1.02 kg.
WLL: 1,666 lbs./755 kg.

45143-22

for tires 8"W x 24"H
Weight: 2.5 lbs./1.14 kg.
WLL: 1,666 lbs./755 kg.



WHEEL DOLLY STRAP

47934-11

2" x 86" with Round Ring
for tires 8"W x 22"H
Weight: 1.0 lbs./46 kg.
WLL: 900 lbs./410 kg.



WHEEL DOLLY STRAP

47935-11

with S Hooks
for tires 10"W x 24"H
Weight: 1.5 lbs./46 kg.
WLL: 800 lbs./360 kg.

47935-12

with Spring E Fittings
for tires 10"W x 24" H
Weight: 1.5 lbs./46 kg.
WLL: 1,300 lbs./590 kg.

SERIES E TRANSIT STRAP W/ RTJ HOOKS



49023-20

6-foot Strap

49023-21

8-foot Strap

49023-22

12-foot Strap

Working Load Limit: 1,000 lbs./454 kg. Fixed End: 14"

Assembled with durable latex treated polyester webbing (41632-13) and Ratchet Buckle (47105-11). Fixed end features a heavy-duty Series E & A Track Fitting (47772-12), and the adjustable end features a Cluster Hook (45515-10) with R, T, and J Hooks.

'TIE DOWNS & 'TRANSIT' S'TRAPs

ADJUSTABLE TIRE BONNETS



30ATB Adjustable Tire Bonnet

for 13" – 17" OEM Tires.
WLL: 1,000 lbs./454 kg.
Weight 3 lbs./1.4 kg.



30RT Double Adjustable Tire Bonnet

for 10" – 22" Wide Tires.
WLL: 3,333 lbs./1,515 kg.
Weight 6 lbs./2.7 kg.

LASHING WINCHES

The lashing winch with double hex drive can be bolted or welded to the trailer like a standard winch, yet offers the quick release and easy operation of a ratchet buckle.

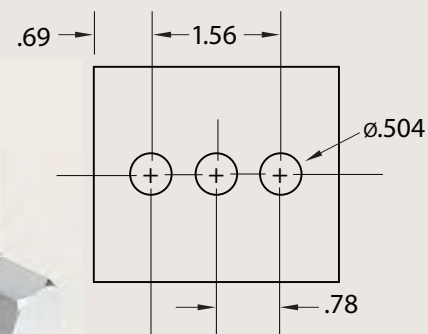

47640-31

With double hex drive and three mounting holes.
WLL: 3,333 lbs./ 1,515 kg.
Weight: 3.8 lbs./1.7 kg.



48496-11

With double hex drive, release latch, and single mounting hole.
WLL: 2,500 lbs./ 1,135 kg.
Weight: 2.2 lbs./1 kg.



Trust Ancra's slings for your lifting and rigging needs. Our durable polyester round slings and eye to eye web slings come in a full range of lengths and widths for your application.

GET A LIFT FROM ANCRA'S SLINGS

Flexible and resistant to abrasion, Ancra's line of durable polyester round slings and polyester twisted eye to eye slings are built for strength and durability. Round slings are color-coded by width from 1" to 7". Eye to eye web slings are available in 1", 2", 3" and 4" web widths in single- and double-ply models. Custom sizes and models may be available.

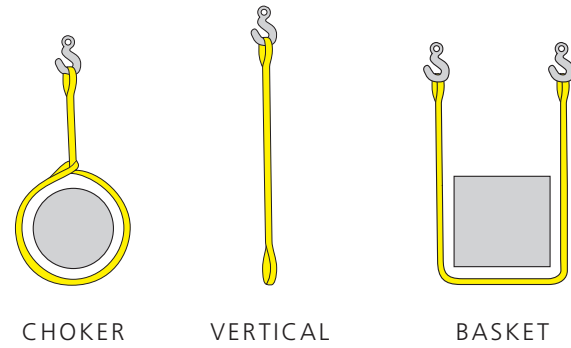

ROUND SLINGS



LIFTING SLINGS — ROUND

Part No.	Description	Choker	Vertical	Basket
20-ENR1X3	1" x 3' Purple Endless Round Sling	2,100	2,600	5,200
20-ENR1X4	1" x 4' Purple Endless Round Sling	2,100	2,600	5,200
20-ENR1X6	1" x 6' Purple Endless Round Sling	2,100	2,600	5,200
20-ENR1X8	1" x 8' Purple Endless Round Sling	2,100	2,600	5,200
20-ENR1X12	1" x 12' Purple Endless Round Sling	2,100	2,600	5,200
20-ENR2X3	2" x 3' Green Endless Round Sling	4,200	5,300	10,600
20-ENR2X4	2" x 4' Green Endless Round Sling	4,200	5,300	10,600
20-ENR2X8	2" x 8' Green Endless Round Sling	4,200	5,300	10,600
20-ENR2X12	2" x 12' Green Endless Round Sling	4,200	5,300	10,600
20-ENR2X20	2" x 20' Green Endless Round Sling	4,200	5,300	10,600
20-ENR3X3	3" x 3' Yellow Endless Round Sling	6,700	8,400	16,800
20-ENR3X4	3" x 4' Yellow Endless Round Sling	6,700	8,400	16,800
20-ENR3X8	3" x 8' Yellow Endless Round Sling	6,700	8,400	16,800
20-ENR3X12	3" x 12' Yellow Endless Round Sling	6,700	8,400	16,800
20-ENR3X20	3" x 20' Yellow Endless Round Sling	6,700	8,400	16,800
20-ENR4X10	4" x 10' Tan Endless Round Sling	8,500	10,600	21,200
20-ENR4X16	4" x 16' Tan Endless Round Sling	8,500	10,600	21,200
20-ENR5X4	5" x 4' Red Endless Round Sling	10,600	13,200	26,400
20-ENR5X6	5" x 6' Red Endless Round Sling	10,600	13,200	26,400
20-ENR5X12	5" x 12' Red Endless Round Sling	10,600	13,200	26,400
20-ENR5X20	5" x 20' Red Endless Round Sling	10,600	13,200	26,400
20-ENR7X6	7" x 6' Blue Endless Round Sling	17,000	21,200	42,400

POLYESTER TWISTED EYE TO EYE WEB SLINGS

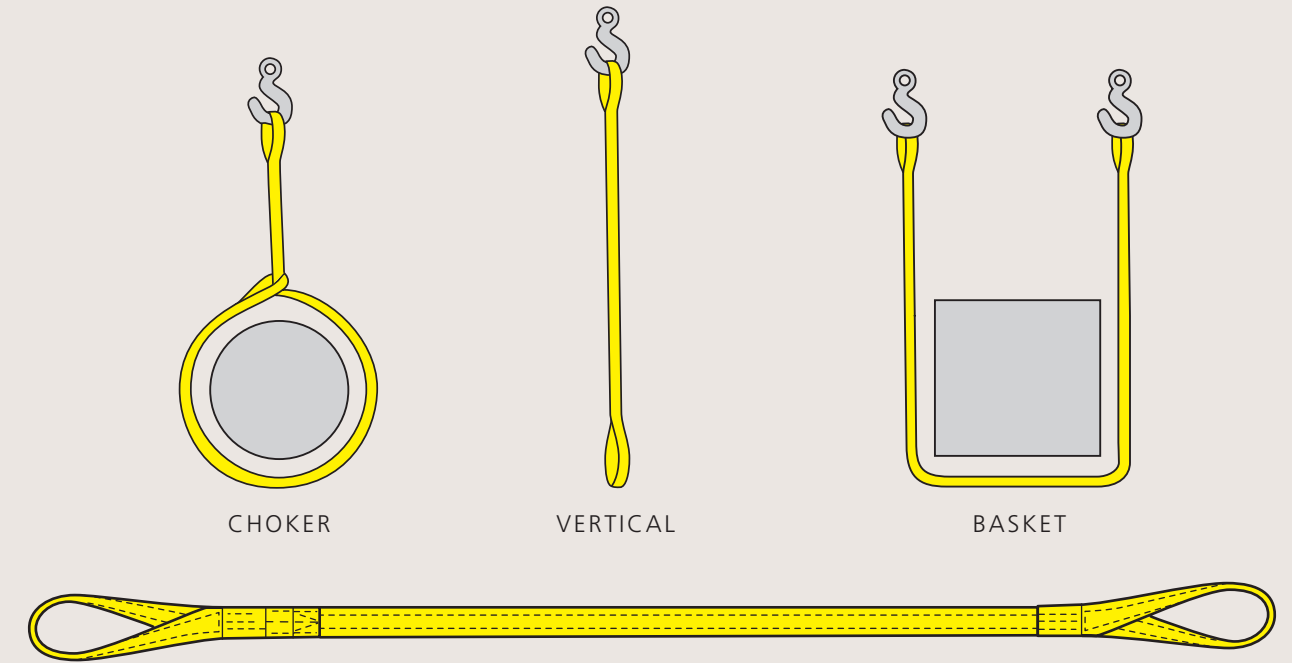

- ▶ Light Weight & Economical
- ▶ 9,800 lbs. Polyester Webbing
- ▶ Single-Ply & Double-Ply Styles
- ▶ Industry Compliant Sewn In Warning Tags
- ▶ Reinforced Eyes
- ▶ Tapered Eyes on 2", 3", & 4" Widths
- ▶ Complies with WSTDA — WS-1-Type IV CL7 Web Slings

SINGLE-PLY 9,800 LB. TWISTED EYE TO EYE SLING

Part No.	Size	Choker	Vertical	Basket
20-EE1-9801X3	1" x 3'	1,250	1,600	3,200
20-EE1-9801X4	1" x 4'	1,250	1,600	3,200
20-EE1-9801X6	1" x 6'	1,250	1,600	3,200
20-EE1-9801X10	1" x 10'	1,250	1,600	3,200
20-EE1-9802X3	2" x 3'	2,450	3,100	6,200
20-EE1-9802X4	2" x 4'	2,450	3,100	6,200
20-EE1-9802X6	2" x 6'	2,450	3,100	6,200
20-EE1-9802X10	2" x 10'	2,450	3,100	6,200
20-EE1-9802X12	2" x 12'	2,450	3,100	6,200
20-EE1-9802X14	2" x 14'	2,450	3,100	6,200

POLYESTER TWISTED EYE TO EYE WEB SLINGS

DOUBLE-PLY 9,800 LB. TWISTED EYE TO EYE SLING

Part No.	Size	Choker	Vertical	Basket
20-EE2-9801X4	1" x 4'	2,450	3,100	6,200
20-EE2-9801X8	1" x 8'	2,450	3,100	6,200
20-EE2-9802X3	2" x 3'	4,950	6,200	12,400
20-EE2-9802X4	2" x 4'	4,950	6,200	12,400
20-EE2-9802X6	2" x 6'	4,950	6,200	12,400
20-EE2-9802X8	2" x 8'	4,950	6,200	12,400
20-EE2-9802X10	2" x 10'	4,950	6,200	12,400
20-EE2-9802X12	2" x 12'	4,950	6,200	12,400
20-EE2-9802X16	2" x 16'	4,950	6,400	12,400
20-EE2-9802X20	2" x 20'	4,950	6,200	12,400
20-EE2-9802X30	2" x 30'	4,950	6,200	12,400
20-EE2-9803X10	3" x 10'	7,000	8,800	17,600
20-EE2-9803X12	3" x 12'	7,000	8,800	17,600
20-EE2-9803X16	3" x 16'	7,000	8,800	17,600
20-EE2-9803X20	3" x 20'	7,000	8,800	17,600
20-EE2-9804X6	4" x 6'	8,800	11,000	22,000
20-EE2-9804X8	4" x 8'	8,800	11,000	22,000
20-EE2-9804X10	4" x 10'	8,800	11,000	22,000
20-EE2-9804X12	4" x 12'	8,800	11,000	22,000
20-EE2-9804X16	4" x 16'	8,800	11,000	22,000
20-EE2-9804X20	4" x 20'	8,800	11,000	22,000
20-EE2-9804X30	4" x 30'	8,800	11,000	22,000

WARNING:

Please read and comply with all warnings on labels and safety bulletins included with each sling. Failure to do so may result in serious property damage, and/or personal injury or death!

DO NOT exceed the rated capacity shown on the package and label attached to the sling.

For Operating and Inspection Manuals for synthetic Web Slings, see the Web Sling and Tie Down Association Publication WSTDA-WS-2.

For Operating and Inspection Manuals for polyester Round Slings, see the Web Slings and Tie Down Association Publication WSTDA-RS-2.

Ankra offers high quality restraint products for both commercial truckers and consumers. For transporting motorcycles, ATVs, household furnishings or equipment, our utility strap assemblies are made of high strength steel components and durable materials. Look to Ancra for years of trouble free use.



UTILITY TIE DOWNS

Ankra Utility Tie Downs are versatile and reliable for securing a wide range of light to medium duty cargo. Made of high-strength steel and abrasion-resistant webbing, they're quick and easy to use for secure performance in recreational, light industrial, and agricultural applications.

MINI RATCHET STRAP



Ratchet strap with Wire Hooks and floating D-Ring for use together or separately. Fixed End: 23" Individually display packaged.

- 43887-10** 1" x 16' Weight: 1.56 lbs./71 kg.
 - 43887-11** 1" x 20' Weight: 1.69 lbs./77 kg.
 - 45988-15** 1" x 9' Weight: 1.33 lbs./60 kg.
- Bulk WLL: 1,000 lbs./454 kg.

ANCRALASH WITH RATCHET BUCKLE STRAP



- 44557-10** 15' long endless multipurpose Ratchet strap. WLL: 400 lbs./181 kg. Weight: .84 lb./38 kg.

HEAVY-DUTY RATCHET STRAP ASSEMBLY



- 44340-11** 1" x 10' Ratchet strap with Wire Hooks for multipurpose use. WLL: 1,000 lbs./454 kg. Weight: 1.60 lbs./73 kg.

ANCRALASH RED UTILITY STRAP



- 41048-10** 1" x 5.5' Cam buckle strap with vinyl-coated S Hooks. Fixed End: 6-in. WLL: 400 lbs./181 kg. Weight: 1.60 lbs./73 kg.
- 41048-23** 1" x 13' Cam buckle strap with vinyl-coated S Hooks. Fixed End: 30-in. WLL: 400 lbs./181 kg. Weight: 1.78 lbs./81 kg.

RATCHETING TIE DOWNS



- 49368-10** 1" x 15' 4-pack 1" red Ratchet strap with vinyl-coated S Hooks secures cargo, equipment and household furnishings. Weight: 4.7 lbs./2.14 kg. WLL: 266 lbs./121 kg.

CAM BUCKLE TIE DOWNS



- 49368-11** 1" x 6' 4-pack 1" black Cam strap with scratch-resistant vinyl-coated S Hooks. A simple way to secure your possessions. Weight: 3.7 lbs./1.69 kg. WLL: 266 lbs./121 kg.

RATCHETING & CAM BUCKLE TIE DOWNS



- 49368-12** Combo Pack Contains two each 1" multipurpose Ratchet and Cam Buckle tie downs with scratch-resistant vinyl coating. Weight: 4.2 lbs./1.91 kg. WLL: 266 lbs./121 kg.

CAM BUCKLE TIE DOWNS



- 95001** 1" x 8' 2-pack 1" Cam strap with vinyl-coated S Hooks. Packaged in an interactive package. Weight: 1.85 lbs./84 kg. WLL: 400 lbs./181 kg.

MULTI-PACK CONSUMER TIE DOWNS

RATCHETING TIE DOWNS



- 95002** 1" x 10' 2-pack 1" black Ratchet straps with vinyl-coated S Hooks in an interactive package. Weight: 2.25 lbs./1.0 kg. WLL: 550 lbs./250 kg.

RETRACTABLE RATCHETING TIE DOWNS



- 95003** 1" x 6' 2-pack 1" black Retractable Ratchet straps with scratch-resistant vinyl-coated S Hooks in an interactive package. Weight: 3.20 lbs./1.45 kg. WLL: 500 lbs./227 kg.

CAM BUCKLE TIE DOWNS



- 95004** 1" x 8' 4-pack 1" red Cam straps with scratch-resistant vinyl-coated S Hooks in an interactive package. Weight: 3.8 lbs./1.72 kg. WLL: 400 lbs./181 kg.

RATCHETING TIE DOWNS



- 95005** 1" x 10' 4-pack 1" black Ratchet straps with vinyl-coated S Hooks in an interactive package. Weight: 4.6 lbs./2.1 kg. WLL: 550 lbs./250 kg.

RATCHETING & CAM BUCKLE TIE DOWNS



- 95006** Combo Pack Contains two each 1" multipurpose 10' Ratchet straps and 8' Cam Buckle tie downs. All have scratch-resistant vinyl-coated S Hooks and are in an interactive package. Weight: 5.20 lbs./1.90 kg. Ratchet Strap WLL: 550 lbs./250 kg. Cam Strap WLL: 400 lbs./181 kg.

RATCHETING TIE DOWNS



- 95007** 1" x 12' Endless Loop, 2-pack, 1" Ratchet straps in an interactive package. Weight: 1.75 lbs./79 kg. WLL: 550 lbs./250 kg.

TRACKSTAR MOTORCYCLE WHEELCHOCK



- 49603-10** Quick Connect to aircraft style L track. Fits tire widths from 3.5" to 5.5". Comes complete with mounting kit. Weight: 7.0 lbs./3.18 kg.

TRACKSTAR ACCESSORY MOUNTING KIT



- 49288-10** TrackStar Accessory Mounting Kit (8" L track & hardware) for installation in a second vehicle.

PICKUP TRUCK CARGO NETS



SHORT BED PICKUPS

50199-10

For short beds - 72" W x 80" L

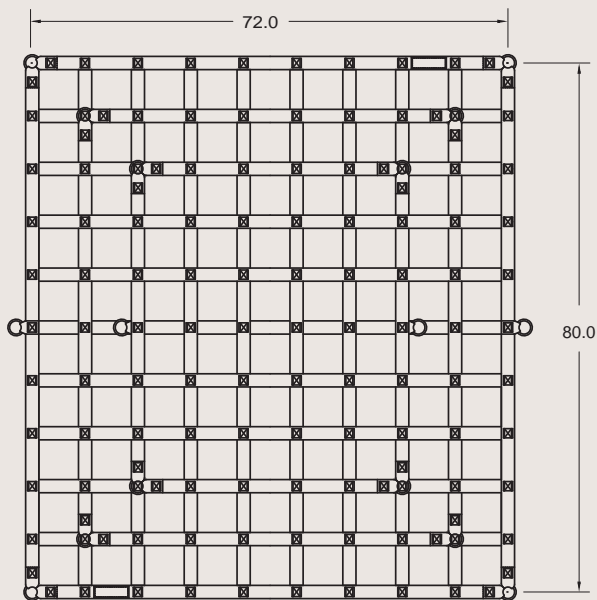

LONG BED PICKUPS

50199-11

For standard beds - 72" W x 96" L

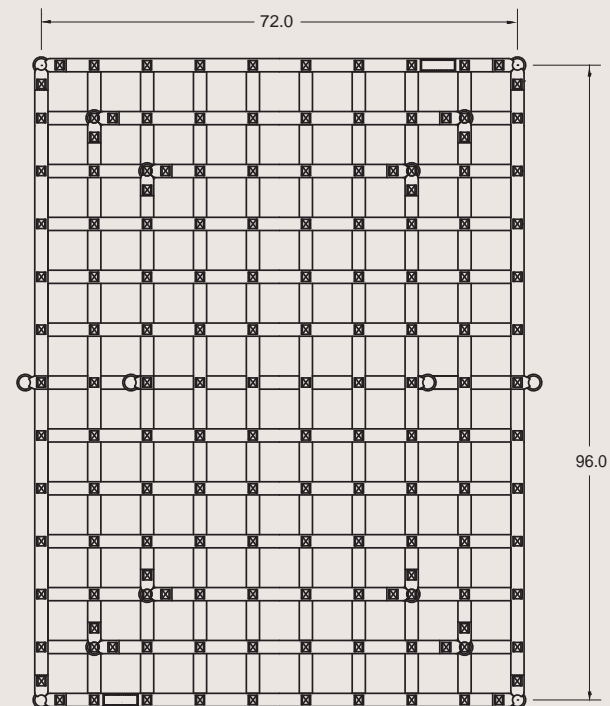

D-Rings and Connectors are spaced to accommodate various heights of loads. Each net comes with six (6), 1-1/4" x 5' long straps with a die cast cam buckle. Each strap has vinyl-coated S hooks with wire keepers to prevent them from disengaging.

Net openings: 6.0"
WLL: 1,200 lbs./540 kg.

We make them tough. Buckles, hooks, rings, track fittings and attachment hardware are made from high-strength steel. Webbing is abrasion-resistant, a trademark of Ancra quality. Standard or custom, these products are the core of Ancra's first-rate reputation.

- Quality materials and solid steel construction ensures long life
- Positive locking feature on tensioning hardware for security
- Wide assortment of hardware and webbing to suit your application
- Protective coatings for improved corrosion resistance



ANCRA BUCKLE QUALITY –

The standard of the industry, Ancra's durable buckles are designed with a unique latch and fast release cam that reduces sprocket wear. Our broad line of steel Ratchet, Cam and Overcenter Buckles meets your wide ranging load requirements, offering quick and easy release and secure locking tension. The popular and often copied long, wide-handle ratchet is a classic example of Ancra innovation. Our locking mechanism guards against vibration release, the 1.5-inch longer handle increases leverage by 20%, and the wider handle and latch design allows more hand room for easier operation. What began as innovation, is now the standard of the industry.



RATCHET BUCKLES

Ancra Ratchet Buckles are available in a wide range of models for 1-inch to 4-inch webbing widths. The buckles have a locking latch that engages when the handle is closed and prevents the inadvertent release of tension when under load. The handle cross pin interlocks with the frame, maintaining a low profile design. A removable rear bolt on most models allows for in field conversion or repair.

1-INCH

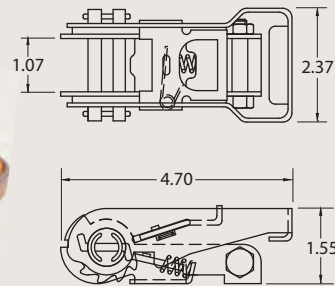

43320-32

WLL: 1,466 lbs./666 kg.
Weight: .76 lb./.34 kg.

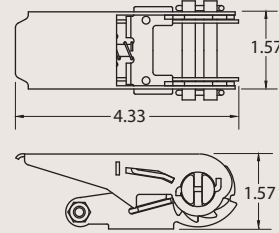

48770-10

Low profile, black powder coat
WLL: 500 lbs./227 kg.
Weight: .50 lb./.22 kg.

1-3/4 INCH

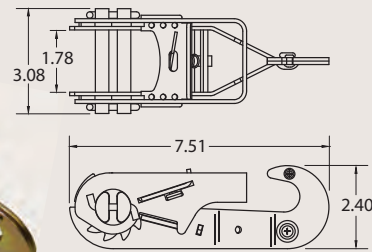

41808-14

1-3/4 in. Hook End
WLL: 2,000 lbs./908 kg.
Weight: 1.65 lbs./.75 kg.

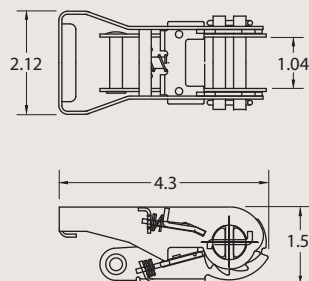

44232-10

WLL: 400 lbs./181 kg.
Weight: .50 lb./.22 kg.

RATCHET BUCKLES

2-INCH

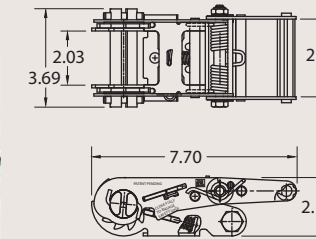

49410-13

Low Profile Torque Limiting. Reduces trailer damage by limiting overzealous tensioning. See page 65.
WLL: 3,666 lbs./1,663 kg.
Weight: 2.7 lbs./1.23 kg.

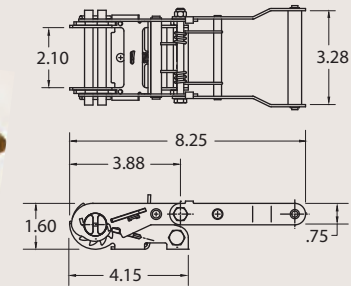

49715-10

Long Wide Handle Torque Limiting. Reduces trailer damage by limiting overzealous tensioning. See page 65.
WLL: 1,500 lbs./680 kg.
Weight: 1.56 lbs./.71 kg.

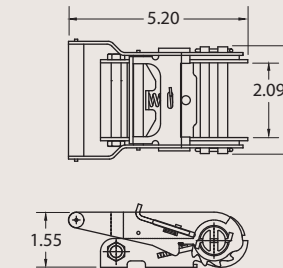

44258-13

Low Profile. Nut & bolt packaged separately.
WLL: 1,500 lbs./680 kg.
Weight: 1.30 lbs./.59 kg.

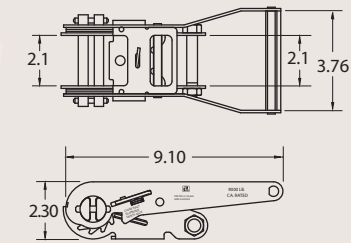

44587-10

Long Wide Handle
WLL: 3,666 lbs./1,666 kg.
Weight: 2.3 lbs./1.05 kg.

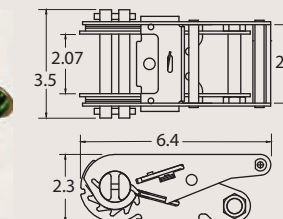

44627-11

Standard Handle
WLL: 3,333 lbs./1,515 kg.
Weight: 2.10 lbs./.95 kg.

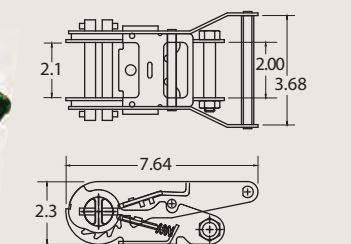

47105-11

Short Wide Handle
WLL: 3,666 lbs./1,666 kg.
Weight: 2.20 lbs./1.0 kg.



50037-10

Long Wide Handle Web Keeper Ratchet Buckle
WLL: 3,666 lbs./1,666 kg.
Weight: 2.35 lbs./1.07 kg.

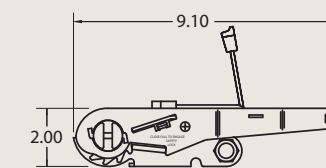
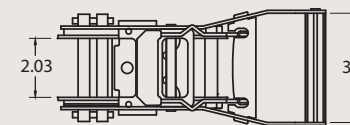

RATCHET BUCKLES

3-INCH

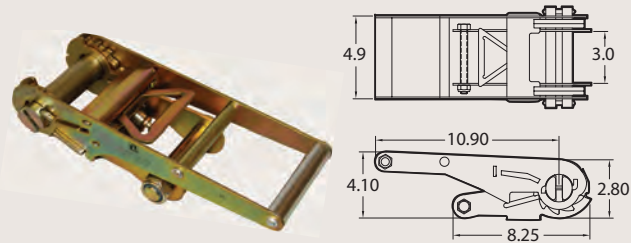

48965-10
WLL: 7,333 lbs./3,333 kg.
Weight: 7.0 lbs./3.18 kg.

4-INCH

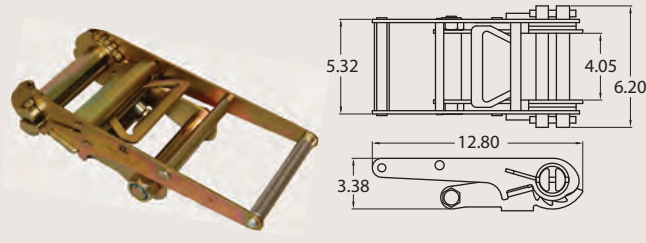

49349-10
WLL: 8,000 lbs./3,636 kg.
Weight: 8.0 lbs./3.63 kg.

OVERCENTER BUCKLES

Ankra Overcenter Buckles have one-piece steel frame construction. Designed for simple and easy operation. When attached to the strap, the webbing provides a pad between the buckle and the cargo.

1-INCH

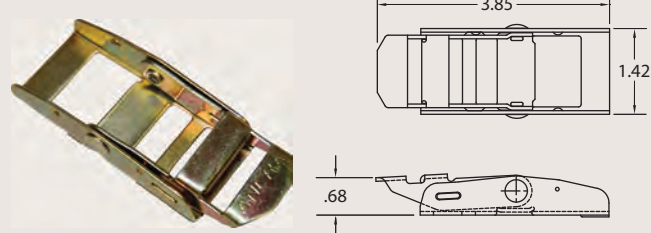

42816-18
WLL: 600 lbs./272 kg.
Weight: .15 lb./06 kg.

2-INCH

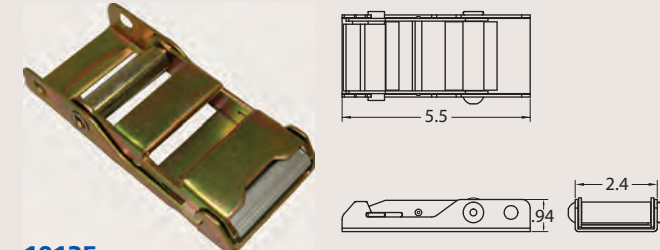

10135
WLL: 3,000 lbs./1,361 kg.
Weight: .8 lbs./36 kg.

1 3/4-INCH

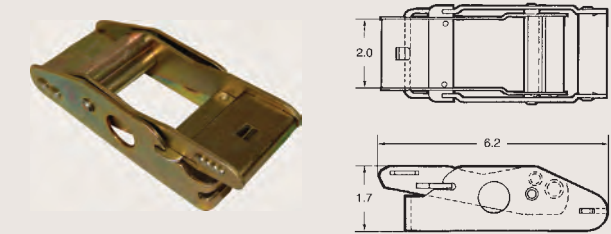

44639-12
WLL: 1,666 lbs./757 kg.
Weight: 1.20 lbs./54 kg.

2-INCH

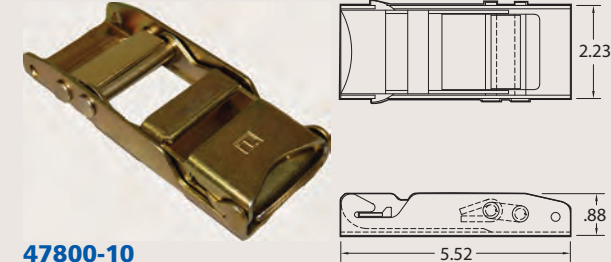

47800-10
WLL: 1,666 lbs./757 kg.
Weight: .70 lb./31 kg.

DID YOU KNOW?

In addition to the trucking industry, Ankra buckles are used in specialty markets that include aircraft, marine, automotive, material handling and military applications. In each case, material specifications have been modified to give optimum performance for their specific use.

CAM BUCKLES

A one-piece frame design lengthens the service life of Ankra Cam Buckles. Quick and easy operation consists of simply pulling the handhold to tension and depressing the cam lever to release.

1-INCH

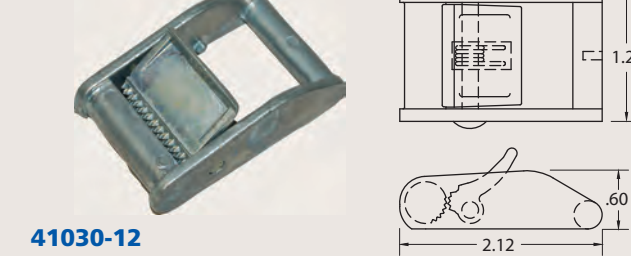

41030-12
WLL: 166 lbs./75 kg.
Weight: .13 lb./06 kg.

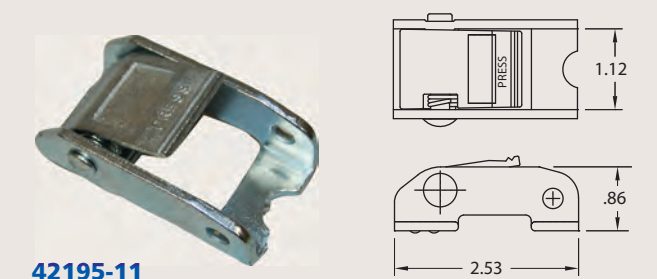

42195-11
WLL: 500 lbs./227 kg.
Weight: .25 lb./11 kg.

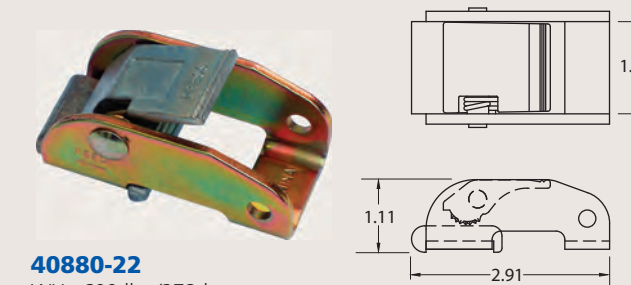

40880-22
WLL: 600 lbs./272 kg.
Weight: .40 lb./18 kg.

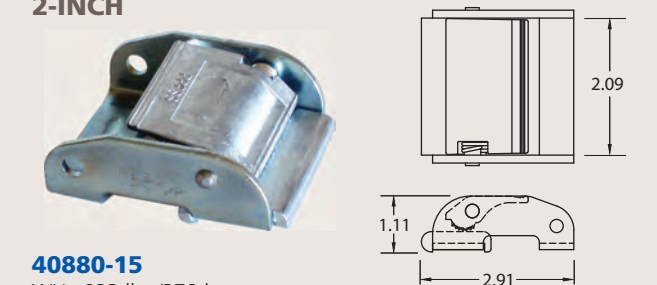

40880-15
WLL: 833 lbs./378 kg.
Weight: .69 lb./31 kg.

ROLLER BUCKLE

A simple slide bar adjuster buckle for light duty applications.



41645-10 Roller Buckle
WLL: 500 lbs./227 kg.
Weight: .20 lb./10 kg.

3-BAR SLIDE ADJUSTER

This adjuster is designed to be used for adjustment of strap lengths only, not for tensioning.

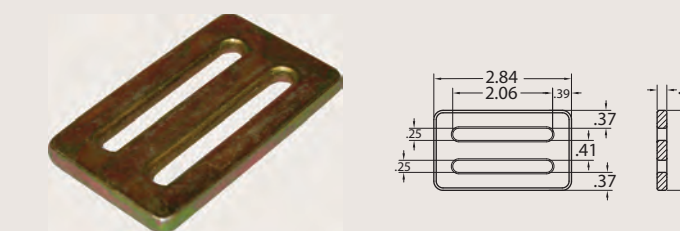









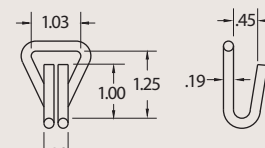

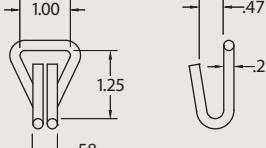

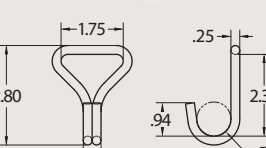

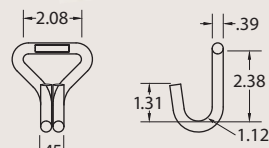

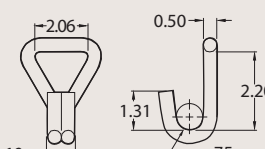

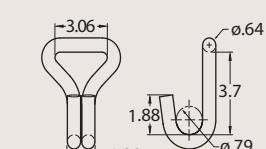

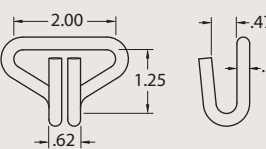
49834-10 3-Bar Slide Adjuster
WLL: 1,000 lbs./454 kg.
Weight: .30 lb./14 kg.

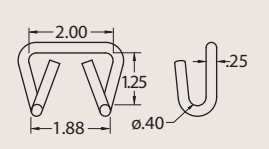
ATTACHMENT HARDWARE

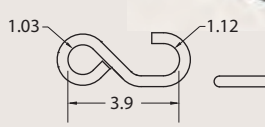
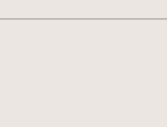
Ancra hooks, rings and fittings are made to last. With heat treating and corrosion resistant plating or vinyl-coating, this quality line of attachment hardware is strong and durable.

WIRE HOOKS

 	 	 	 
<p>40316-12 1-inch Narrow Hook WLL: 166 lbs./75 kg. Weight: .10 lb./05 kg.</p>	<p>40024-10 1-inch Narrow Hook WLL: 1,000 lbs./454 kg. Weight: .10 lb./05 kg.</p>	<p>43120-19 1 3/4-inch Narrow Hook WLL: 500 lbs./227 kg. Weight: .17 lb./08 kg.</p>	<p>43120-11 2-inch Narrow Hook WLL: 1,666 lbs./757 kg. Weight: .39 lb./18 kg.</p>
 	 	 	 
<p>43120-13 2-inch Narrow Hook WLL: 3,333 lbs./1,515 kg. Weight: .62 lb./28 kg.</p>	<p>43120-20 3-inch Narrow Hook WLL: 7,333 lbs./3,333 kg. Weight: 1.39 lbs./63 kg.</p>	<p>40024-12 2-inch Narrow Hook WLL: 833 lbs./378 kg. Weight: .10 lb./05 kg.</p>	<p>40023-12 2-inch Wide Hook WLL: 833 lbs./378 kg. Weight: .12 lb./06 kg.</p>
 	 	 	
<p>41313-12 Zinc-plated S Hook WLL: 400 lbs./181 kg. Weight: .28 lbs./13 kg.</p>	<p>41313-13 1-inch Vinyl S Hook WLL: 400 lbs./181 kg. Weight: .29 lb./13 kg.</p>	<p>41313-19 1-inch Vinyl S Hook Heat Treated WLL: 600 lbs./272 kg. Weight: .30 lb./14 kg.</p>	

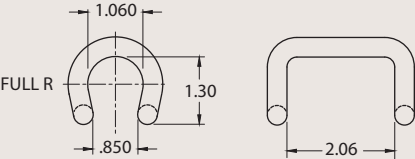
 	<p>45228-10 Rave Hook WLL: 1,167 lbs./530 kg. Weight: .29 lb./13 kg.</p>
---	---

ATTACHMENT HARDWARE

FLAT HOOKS

 	 
<p>43546-10 1-inch Gutter Hook WLL: 250 lbs./113 kg. Weight: .05 lb./02 kg.</p>	<p>40065-10 1-inch Plated Flat Hook WLL: 333 lbs./151 kg. Weight: .04 lb./02 kg.</p>
 	 
<p>40065-12 1-inch Vinyl Flat Hook WLL: 333 lbs./151 kg. Weight: .05 lb./02 kg.</p>	<p>40044-10 1-inch Flat Hook with Keeper WLL: 1,166 lbs./530 kg. Weight: .68 lb./31 kg.</p>
 	 
<p>43099-10 2-inch Flat Hook WLL: 1,666 lbs./757 kg. Weight: .40 lb./18 kg.</p>	<p>40891-18 2-inch Flat Hook WLL: 3,333 lbs./1,515 kg. Weight: .68 lb./31 kg.</p>
 	 
<p>41766-18 3-inch Flat Hook WLL: 5,400 lbs./2,450 kg. Weight: .98 lb./45 kg.</p>	<p>41766-19 3-inch Flat Hook with Keeper WLL: 5,400 lbs./2,450 kg. Weight: 1.03/47 kg.</p>
	
<p>48968-11 2-inch Container Hook WLL: 5,400 lbs./2,450 kg. Weight: 2.0 lbs./91 kg.</p>	<p>49770-10 4-inch Heavy-Duty Waste Hook WLL: 5,100 lbs./2,313 kg. Weight: 5.0 lbs./2.27 kg.</p>

ATTACHMENT HARDWARE

SNAP HOOKS

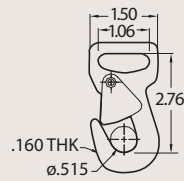

43044-10

1-inch Snap Hook
WLL: 1,666 lbs./757 kg.
Weight: .20 lb./09 kg.

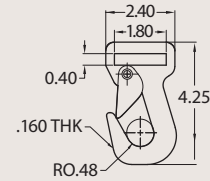

40084-14

2-inch Snap Hook
WLL: 2,100 lbs./953 kg.
Weight: .34 lb./15 kg.

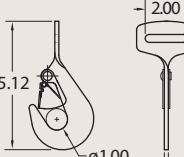

40758-11

2-inch Snap Hook w/ Satin Black Finish. Twisted Version
WLL: 3,333 lbs./1,515 kg.
Weight: .59 lb./27 kg.

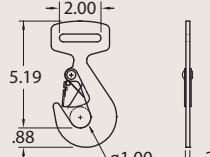

40758-13

2-inch Snap Hook w/ Satin Black Finish
WLL: 3,333 lbs./1,515 kg.
Weight: .59 lb./27 kg.

RINGS



47944-10

Round Ring
WLL: 900 lbs./409 kg.
Weight: .25 lbs./11 kg.

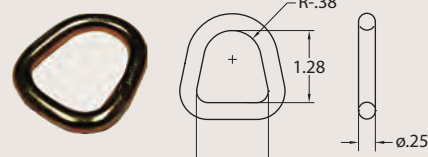

40025-10

1-inch D-Ring
WLL: 1,666 lbs./757 kg.
Weight: .05 lb./02 kg.

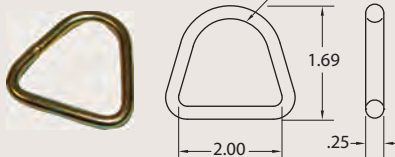

40025-12

2-inch D-Ring
WLL: 1,666 lbs./757 kg.
Weight: .09 lb./04 kg.

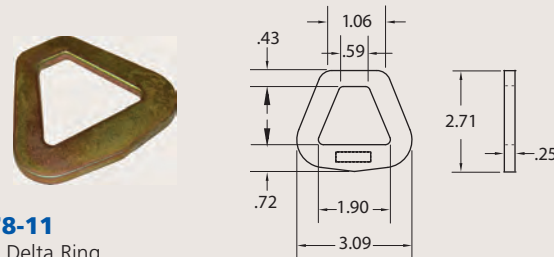

40978-11

2-inch Delta Ring
WLL: 3,333 lbs./1,515 kg.
Weight: .28 lb./13 kg..

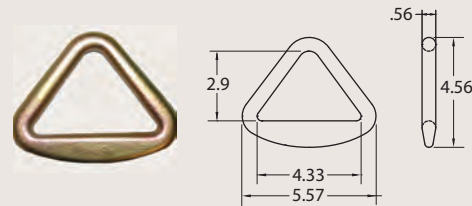

41631-12

4-inch Delta Ring
WLL: 6,666 lbs./3,030 kg.
Weight: 1.30 lbs./59 kg.

PRODUCT FEATURES

- + ANCRÁ'S RUST-RESISTANT, HIGH QUALITY ATTACHMENT HARDWARE IS MADE TO LAST.
- + OUR PRODUCTS AND COMPONENTS ARE FULLY TESTED TO MEET OUR EXACTING STANDARDS.

ATTACHMENT HARDWARE

BOLT PLATES

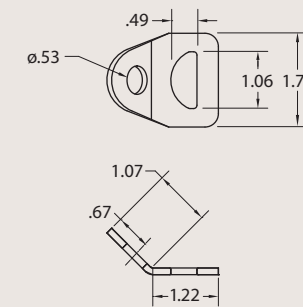

49917-10 1", 45 degree
Heat treated, Zinc Plated Gold Chromate Finish.
WLL: 1,000 lbs./450 kg.
Weight: .10 lbs./05 kg.

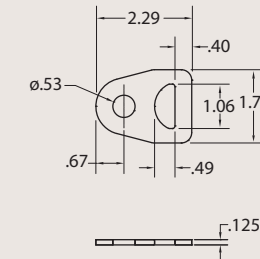

49917-11 1", Flat
Heat treated, Zinc Plated Gold Chromate Finish.
WLL: 1,000 lbs./450 kg.
Weight: .10 lbs./05 kg.

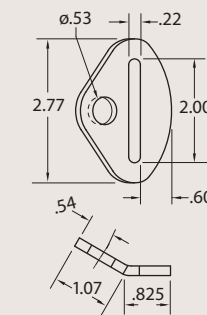

48904-10 2", 30 degree
Heat treated, Zinc Plated Clear Chromate Finish.
WLL: 1,000 lbs./450 kg.
Weight: .14 lbs./07 kg.

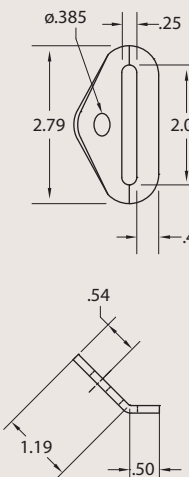

49968-10 2", 45 degree
Heat treated, Chrome Plated Finish.
WLL: 1,000 lbs./450 kg.
Weight: .10 lbs./05 kg.

OUR COMMITMENT TO
QUALITY IS NEVER ENDING



All Angra products and components are fully tested to meet our exacting standards.

ATTACHMENT HARDWARE

Designed to fit securely into Ancra Track, sturdy Ancra Track Fittings are easy to use and long wearing.

TRACK FITTINGS

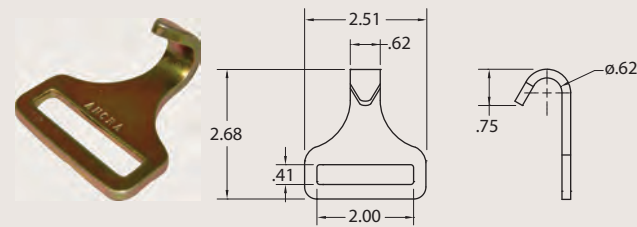

42012-12
Series F Heavy-Duty Track Hook
WLL: 800 lbs./363 kg.
Weight: .20 lb./09 kg.

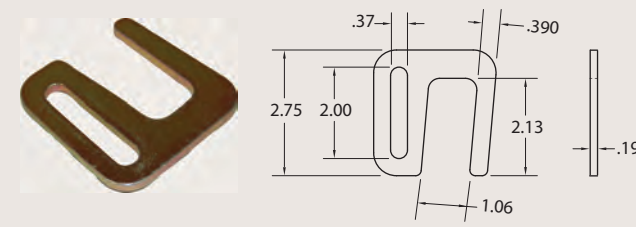

41325-10
Slat Hook. For use with Attachment Rails (Wooden Slats).
WLL: 1,000 lbs./454 kg.
Weight: .23 lb./10 kg.

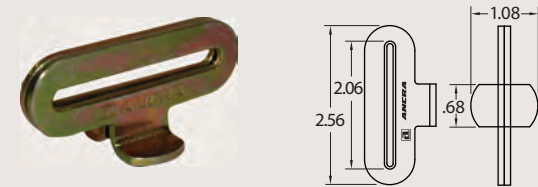

40980-11
Series F Track Fitting for 3/4" hole diameter (USA)
WLL: 500 lbs./225 kg.
Weight: .60 lb./27 kg.

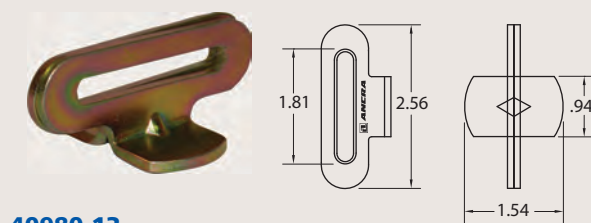

40980-13
For 1" hole diameter track (Canada)
WLL: 500 lbs./225 kg.
Weight: .60 lb./27 kg.

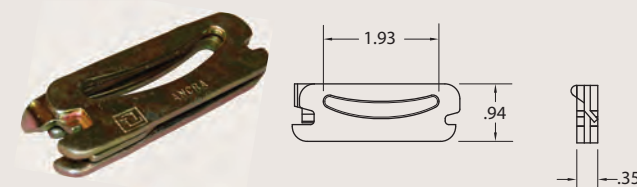

41409-13
Series E & A 3-Piece Track Fitting
WLL: 1,000 lbs./454 kg.
Weight: .20 lb./09 kg.

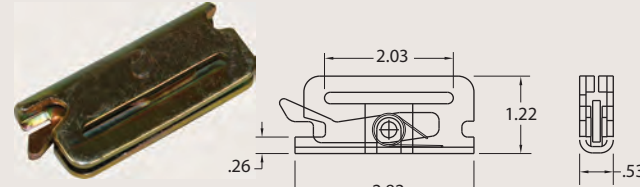

47608-21
Series E & A Track Spring Fitting
WLL: 1,333 lbs./605 kg. in 12-ga. track,
WLL: 1,500 lbs./680 kg. in 11-ga. track.
Weight: .22 lb./10 kg.

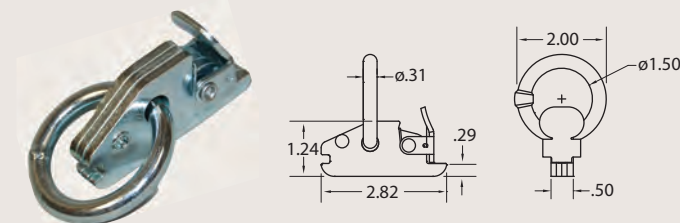

50115-10
Heavy-Duty Series E and A Track Fitting w/ Round Ring. Heat treated.
WLL: 2,000 lbs./900 kg.
Weight: .40 lbs./18 kg.

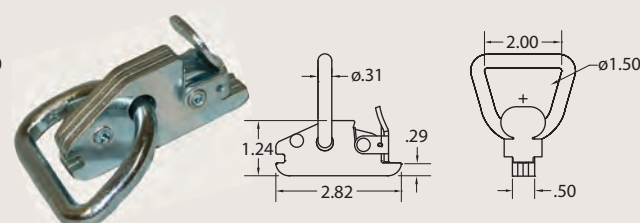

50115-11
Heavy-Duty Series E and A Track Fitting w/ D-Ring. Heat treated.
WLL: 2,000 lbs./900 kg.
Weight: .40 lbs./18 kg.

ATTACHMENT HARDWARE

TRACK FITTINGS



49542-10
Series E & A Fitting w/ D-Ring
WLL: 1,000 lbs./454 kg.
Weight: .32 lb./15 kg.

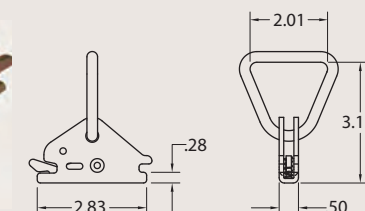

47772-12
Series E & A Track Fitting
WLL: 1,000 lbs./454 kg.
Weight: .45 lb./20 kg.

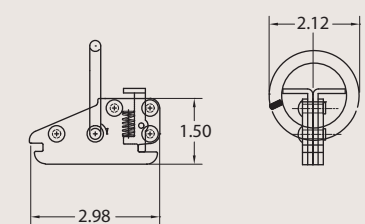

49914-10
Swivel J Idler Hook
Heat treated w/ gold zinc finish.
WLL: 3,333 lbs./1,515 kg.
Weight: 1.12 lbs./51 kg.

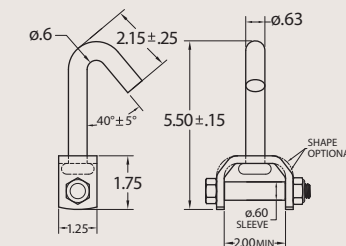

49914-11
Low Profile Swivel J Idler Hook
Heat treated w/ gold zinc finish.
WLL: 3,333 lbs./1,515 kg.
Weight: .87 lb./40 kg.

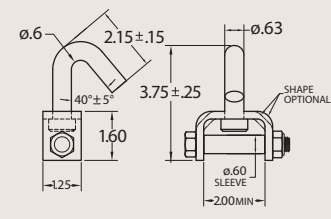

CHAIN ATTACHMENTS



43366-21
Chain Anchor with Delta Ring for 2" Strap Assemblies. 5/16", G43 Chain and Grab Hook, gold zinc plated.
WLL: 3,330 lbs./1,510 kg.
Weight: 2.55 lbs./1.16 kg.

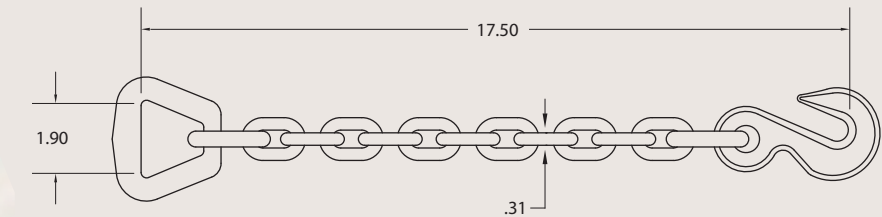

43366-14
Chain Anchor with Delta Ring for 3" & 4" Strap Assemblies. 3/8", G43 Chain and 3/8" G70 Grab Hook, gold zinc plated.
WLL: 5,400 lbs./2,450 kg.
Weight: 3.4 lbs./1.54 kg.

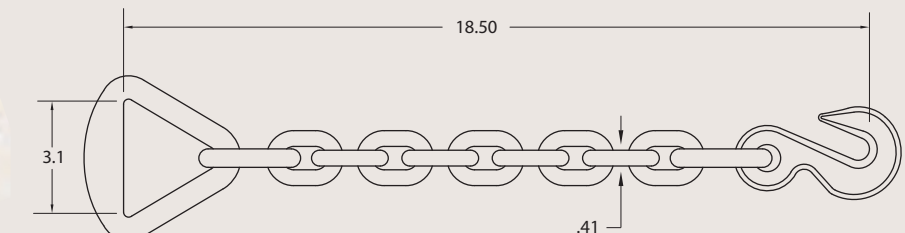

ATTACHMENT HARDWARE

Forged from high strength alloy steel, Ancra clevis hooks are made for Grade 70 chain. Sized from 1/4" to 1/2", the chain hooks are strength tested and heat treated for safety and durability. Meets Department of Transportation requirements.

Forged steel hook, Zinc Plated Gold Chromate finish. Individually polybagged.

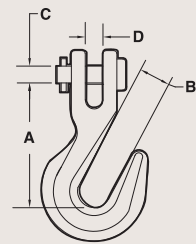

- 45946-12** 1/4-in. Clevis Hook WLL: 3,150 lbs./1,430 kg. Weight: .40 lbs./.18 kg.
- 45946-10** 5/16-in. Clevis Hook WLL: 4,700 lbs./2,130 kg. Weight: .85 lbs./.39 kg.
- 45946-11** 3/8-in. Clevis Hook WLL: 6,600 lbs./2,990 kg. Weight: 1.10 lbs./.5 kg.
- 45946-13** 1/2-in. Clevis Hook WLL: 11,300 lbs./5,130 kg. Weight: 2.10 lbs./1.04 kg.

DIMENSION TABLE				
	A	B	C	D
45946-12	2.00	.40	.31	.36
45946-10	2.30	.43	.38	.38
45946-11	2.70	.50	.48	.44
45946-13	3.20	.66	.63	.75

Replacement G70 Clevis Pin

High strength steel replacement clevis pins are designed to meet the strength requirements of Grade 70 hooks and their heads are marked G7 or 70.

- NEW 50412-100** Packaged Kit Includes one zinc plated clevis pin and cotter pin for a 5/16 Grade 70 chain hook. Weight: .17 lb./.07 kg.
- NEW 50412-102** Packaged Kit Includes one zinc plated clevis pin and cotter pin for a 3/8 Grade 70 chain hook. Weight: .22 lb./.09 kg.
- NEW 50412-103** Packaged Kit Includes one zinc plated clevis pin and cotter pin for a 1/2 Grade 70 chain hook. Weight: .23 lb./.10 kg.

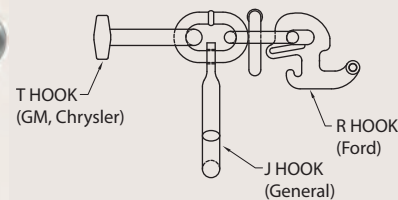
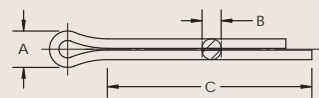
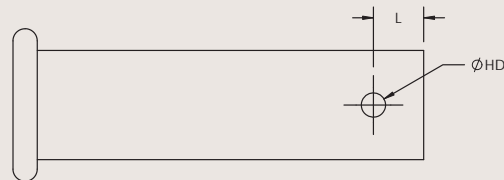
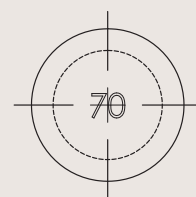

45515-10
RTJ Cluster Hook
WLL: 3,900 lbs./1,770 kg.
Weight: 2.65 lbs./1.20 kg.

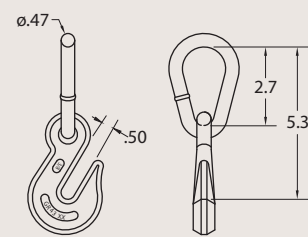

43365-12
Grab Hook Assembly
Heat Treated, Gold Zinc plated finish.
WLL: 5,400 lbs./2,450 kg.
Weight: 1.60 lbs./.73 kg.

CHAIN HARDWARE

We offer a wide selection of chain hardware for popular applications — from anchor shackles with screw pins and clevis pin models to Quick Links in various sizes. Corrosion resistant, gold zinc plated Grade 70 Twin Clevis and Slip Hooks come in a wide range of sizes, with and without safety latches. All are individually packaged.

Screw Pin Anchor Shackle — Galvanized and individually polybagged

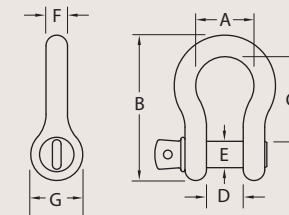

PART NUMBER	SIZE	WEIGHT	WLL
50013-31	5/16-in.	.18 lbs./08 kg.	1,500 lbs./681 kg.
50013-38	3/8-in.	.30 lbs./14 kg.	2,000 lbs./900 kg.
50013-44	7/16-in.	.49 lbs./22 kg.	3,000 lbs./1,362 kg.
50013-50	1/2-in.	.74 lbs./34 kg.	4,000 lbs./1,816 kg.
50013-63	5/8-in.	1.44 lbs./65 kg.	6,500 lbs./2,951 kg.
50013-75	3/4-in.	2.16 lbs./98 kg.	9,500 lbs./4,313 kg.
50013-88 NEW	7/8-in.	3.37 lbs./1.52 kg.	13,000 lbs./5,896 kg.
50013-100 NEW	1-in.	5.30 lbs./2.4 kg.	17,000 lbs./7,711 kg.

	A	B	C	D	E	F	G
50013-31	.81	2.25	1.25	.53	Ø3/8	Ø.31	1.00
50013-38	.94	2.61	1.44	.66	Ø7/16	Ø.38	1.13
50013-44	1.06	3.01	1.69	.72	Ø1/2	Ø.44	1.25
50013-50	1.19	3.34	1.88	.81	Ø5/8	Ø.50	1.38
50013-63	1.50	4.04	2.41	1.06	Ø3/4	Ø.63	1.88
50013-75	1.75	5.04	2.84	1.25	Ø7/8	Ø.75	2.13
50013-88	2.00	5.86	3.31	1.44	Ø1.00	Ø.75	2.38
50013-100	2.31	6.63	3.75	1.69	Ø1.13	Ø.75	2.63

Clevis Pin Anchor Shackle — Galvanized and individually polybagged

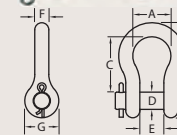

PART NUMBER	SIZE	WEIGHT	WLL
50014-50	1/2-in.	.74 lbs./34 kg.	4,000 lbs./1,816 kg.
50014-63	5/8-in.	1.44 lbs./65 kg.	6,500 lbs./2,951 kg.

	A	B	C	D	E	F	G
50014-50	1.19	3.39	1.88	Ø5/8	.81	Ø.50	1.38
50014-63	1.50	4.17	2.41	Ø3/4	1.06	Ø.63	1.88

Quick Links — Zinc plated clear chromate and individually polybagged

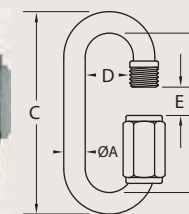

PART NUMBER	SIZE	WEIGHT	WLL
50016-25	1/4-in.	.062 lbs./028 kg.	880 lbs./399 kg.
50016-31	5/16-in.	.154 lbs./07 kg.	1,760 lbs./799 kg.
50016-38	3/8-in.	.198 lbs./90kg.	2,200 lbs./998 kg.

	A	B	C	D	E
50016-25	.235	1.85	2.31	.51	.32
50016-31	.313	2.32	2.95	.65	.41
50016-38	.350	2.54	3.22	.67	.43

CHAIN HARDWARE

Twin Clevis G70 — Forged steel with Zinc Plated Gold Chromate finish and individually polybagged.

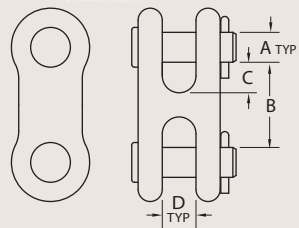

PART NUMBER	SIZE	WEIGHT	WLL	
50017-10	1/4-in. – 5/16-in.	.30 lbs./14 kg.	4,700 lbs./2,130 kg.	
50017-11	3/8-in.	.40 lbs./18 kg.	6,600 lbs./2,990 kg.	
50017-12	7/16-in – 1/2-in.	.98 lbs./44 kg.	11,300 lbs./5,130 kg.	
	A	B	C	D
50017-10	.38	1.18	.43	.47
50017-11	.47	1.34	.48	.53
50017-12	.56	1.75	.63	.65

Slip Hooks G70 without Safety Latch — Forged steel with Zinc Plated Gold Chromate finish and individually polybagged.

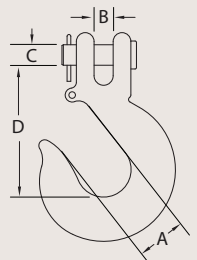

PART NUMBER	SIZE	WEIGHT	WLL	
50019-10	1/4-in.	.44 lbs./20 kg.	3,150 lbs./1,430 kg.	
50019-11	5/16-in.	.75 lbs./34 kg.	4,700 lbs./2,130 kg.	
50019-12	3/8-in.	1.13 lbs./51 kg.	6,600 lbs./2,990 kg.	
50019-13	1/2-in.	2.75 lbs./1.25 kg.	11,300 lbs./5,130 kg.	
	A	B	C	D
50019-10	.94	.44	.38	2.44
50019-11	1.06	.41	.44	2.72
50019-12	1.31	.59	.47	3.25
50019-13	1.75	.75	.63	4.00

Slip Hooks G70 with Safety Latch — Forged steel with Zinc Plated Gold Chromate finish and individually polybagged.

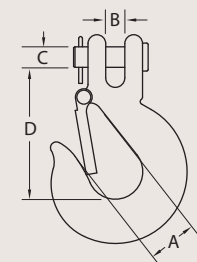

PART NUMBER	SIZE	WEIGHT	WLL	
50019-20	1/4-in.	.59 lbs./27 kg.	3,150 lbs./1,430 kg.	
50019-21	5/16-in.	.92 lbs./42 kg.	4,700 lbs./2,130 kg.	
50019-22	3/8-in.	1.32 lbs./60 kg.	6,600 lbs./2,990 kg.	
50019-23	1/2-in.	2.90 lbs./1.32 kg.	11,300 lbs./5,130 kg.	
	A	B	C	D
50019-20	.94	.44	.38	2.44
50019-21	1.06	.41	.44	2.72
50019-22	1.31	.59	.47	3.25
50019-23	1.75	.75	.63	4.00

WEBBING

Along with exceptional quality, Ancra's broad line of webbing gives you a range of choices to match your application. Custom made according to our strict specifications, Ancra webbing is treated for extra strength and durability, offering additional flexibility and ease of use.



Width in./mm.		Breaking Strength Capacity		Type	Standard Color	Part No.							
in.	mm.	lbs.	kg.										
1.00	25	4,500	2,045	Nylon	<ul style="list-style-type: none"> ■ Red ■ Blue ■ Black 	41820-10-RL 41820-14-RL 41820-15-RL							
							2.00	50	6,000	2,727	Polyester	<ul style="list-style-type: none"> ■ Yellow 	47200-61-BULK-CUT
2.00	50	6,000	2,727	Polyester	<ul style="list-style-type: none"> ■ Blue ■ Red 	47200-62-BULK-CUT 47200-64-BULK-CUT							
							2.00	50	12,000	5,454	Polyester, Latex Treated	<ul style="list-style-type: none"> ■ Blue ■ Yellow ■ Red 	41632-26-BULK-CUT 41632-31-BULK-CUT 41632-19-BULK-CUT
4.00	100	20,000	9,090	Polyester, Latex Treated	<ul style="list-style-type: none"> ■ Gray ■ Blue ■ Red ■ Yellow ■ Green 	43797-18-BULK-CUT 43797-19-BULK-CUT 43797-23-BULK-CUT 43797-36-RL 43797-34-BULK-CUT							

Webbing will have a longer life if stored in a dry, dark location. Continuous exposure to ultra-violet light can degrade the strength of synthetic webbing.

WEBBING CHARACTERISTICS



Nylon's elongation characteristics make it suitable for slings and tow straps, but less desirable for heavy-duty tie downs. It displays good UV, abrasion, alkaline resistance and color fast properties. Polyester is well suited for webbing because of its low cost, high-strength, and resistance to abrasion. It also withstands acid environments and resists elongation in high moisture applications. Its durability and abrasion resistance can be increased even further with coatings of latex or other materials.

SPECIALTY PRODUCTS

AIRCRAFT STYLE SEAT / LOGISTIC TRACK

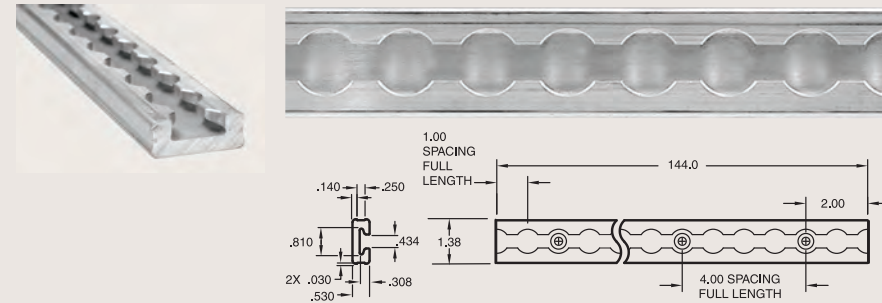

40467-33-144

12' long. Weight: 7.0 lbs./3.2 kg.

HEAVY-DUTY BEVELED AIRCRAFT STYLE TRACK

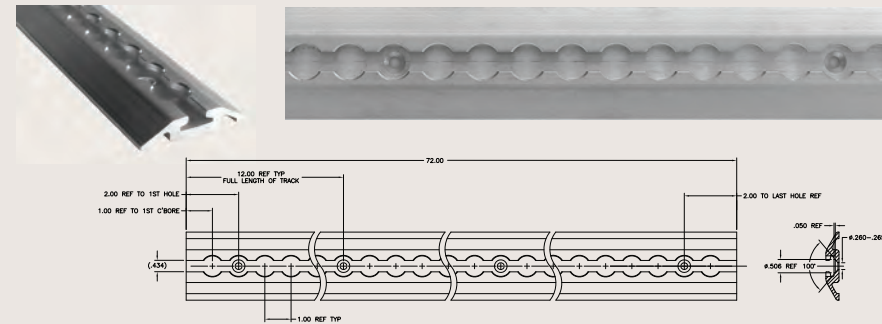

50193-30-72.00

72" long. Weight: 4.30 lbs./1.95 kg.

SINGLE STUD TRACK FITTING

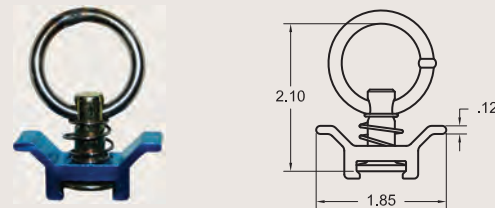

50112-10 Single Stud Track Fitting
Aluminum Retainer. WLL: 1,333 lbs./605 kg. Vertical.
Weight: .12 lb./0.05 kg.

*Load rating varies with the angle of pull.

DOUBLE STUD TRACK FITTING WITH ROUND RING

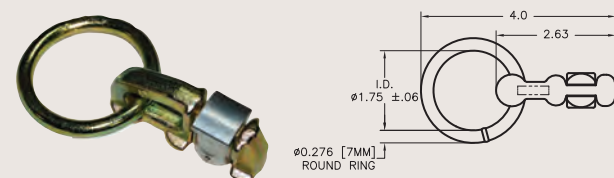

50362-11 Double Stud Track Fitting with Round Ring
WLL: 1,666 lbs./756 kg. Vertical.
Weight: .32 lb./0.14 kg.

Dedicated to You

Ankra designs and manufactures a full spectrum of restraints and hardware to meet your wide ranging needs. Our specialty items represent our ongoing mission to provide the right solutions for a changing industry. If you can't find a specific product in this catalog, or if you have a particular requirement that calls for a unique solution, give us a call. Our customization capabilities can be your assurance that you have Ankra quality for all your cargo restraint applications.



SPECIALTY PRODUCTS

12 & 20 TON BOTTLE JACKS

49880-12

12 Ton Bottle Jack w/ 3-Pc. Handle
Weight: 16.7 lbs./7.58 kg.

- 24,000 lb./10,900 kg. rated capacity
- Compact 7.5-inch height
- Lifts 4.1 inches
- Adjustable to screw height of 2.6 inches
- Extends to 14 inches
- Complies with ASME PALD-2005 standard



49880-20

20 Ton Bottle Jack w/ 3-Pc. Handle
Weight: 24.9 lbs./11.30 kg.

- 40,000 lb./18,180 kg. rated capacity
- Compact 7.5-inch height
- Lifts 3.9 inches
- Adjustable screw height of 2.6 inches
- Extends to 14 inches
- Complies with ASME PALD-2005 standard



FORK LIFT STAND ALLOWS EASIER ACCESS FOR MAINTENANCE AND REPAIR

LR0401-01 Fork Lift Stand

Designed to comply with ASME PASE 2014 Standard for Portable Automotive Service Equipment, Ankra's American-made Fork Lift Stand offers a stable platform to raise your fork lift 20 inches for easier access from all sides. Dimensions: 48" w x 20" h x 180" d Weight: 1,260 lbs./571 kg.

- For lifts up to 10,000 lbs. with 62" maximum wheelbase and 30-40" track width
- 20,000 lbs. evenly distributed load capacity rating for properly installed assembly
- Includes removable approach ramps
- Protective lip lets operator know when to stop fork lift



SHOWCASE ANKRA PRODUCTS WITH CARGO CONTROL DISPLAYS

Display your cargo bars, beams, straps, coil racks and other Ankra products with display racks that break down and take less space in transportation and warehousing. Available in two sizes — free standing and wall mounted, the secure displays come with hooks and offer flexibility in customizing your featured products.

50398-20

Cargo Control Display
Freestanding.
Dimensions: 24" x 20" x 71"
Weight: 100 lbs./45.5 kg.
28 Hooks provided.
Shipping size: 75" x 13" x 24"



MERCHANDISING AIDS

Contact our Customer Service Department to obtain.



Floor Stickers



Sold Here Sticker

Outdoor Banner



X-TREME_CC



Ergo_Bar_CC

Product_CC

Goldline_CC

Wall Chart



Catalog-220-LAM



Cargo Bar Display
49458-10



Part No.

Description

OUTDOOR_BANNER
SOLD_HERE_STICKER
FLOOR_STICKERS
CATALOG-220-LAM

OUTDOOR BANNER, 6' x 3' w/ 4 grommets
SOLD HERE WINDOW STICKER, 5" x 9-1/2"
TIE DOWN ZONE FLOOR GRAPHICS, 11" x 17"
CATALOG 220 LAMINATED

49458-10
WALL_CHART
ERGO_BAR_CC
X-TREME_CC

CARGO BAR DISPLAY
CARGO CONTROL WALL CHART - 18" x 24"
ERGO BAR COUNTER CARD, 8-1/2" x 11"
X-TREME PRODUCT COUNTER CARD, 8-1/2" x 11"

PRODUCT_CC
GOLDLINE_CC
LAD_TRAINING_DVD
LAD_SALES_DVD

CARGO CONTROL COUNTER CARD, 8-1/2" x 11"
GOLDLINE TARP TIES COUNTER CARD, 8-1/2" x 11"
LIFT A DECK II TRAINING VIDEO (DVD)
LIFT A DECK II SALES VIDEO (DVD)

GLIDELOCK_DVD

GLIDELOCK VIDEO (DVD)

Various Product Literature Available Upon Request



Ankra's cargo restraint products are backed by outstanding service:

Customer Assistance:

- Bar coding on standard products
- Technical training manuals
- CD ROM marketing material assistance
- Point of purchase selling aids

Engineering and Technical Services:

- Product development
- Design and drawing check – 3D solids
- Product testing and evaluation

Quality Assurance:

- Product inspection
- Vendor qualifications
- Internal and supplier audits
- Product and lot testing

SPECIFICATIONS

Working Load Limit (WLL)

The maximum load a component or assembly should be subjected to during routine use.

Rated Load Capacity

Ratings are generally established and/or regulated by industry or legislative standards and may vary from industry to industry. The working load limit rating (WLL) is established by Federal Motor Carriers Safety Administration standards at 1/3 of the Breaking Strength of the assembly.

Note: All strengths referenced in this brochure unless noted, are based on a straight pull application.

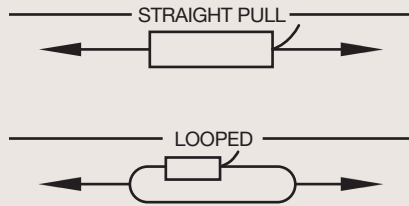

IMPORTANT NOTE:

It is the owner's and user's responsibility to determine suitability of a product for any particular use. Check all applicable industry, trade association, federal, state and local regulations. Read all operating instructions and warnings carefully.

All ratings shown in this catalog are based on the product being new, and used in normal environmental conditions. Special consideration must be given to item selection when unusual conditions can be expected. Particular caution should be exercised to avoid exposing the product to sharp edges, acids, alkalis and temperatures above 194°F.

Products are subjected to age, wear, and deterioration, all of which cause a reduction in the product's working load limit. We recommend that all products be regularly inspected. Any worn, deformed, misused or overloaded products should be replaced.

CAUTION! The component with the lowest working load capacity in the entire restraint system will determine its strength. Each component of the entire system plays an important part in restraining cargo. It is important that tie downs be attached to anchorage that are of sufficient strength to properly secure the load. For example, if one anchors a standard web binder assembly with a rated WLL of 5,000 lbs. to a device with a WLL of 1,000 lbs., then that system is only as good as the anchorage and would be limited to a 1,000 lbs. capacity WLL.

The purpose of this catalog is to assist our customers in the selection of cargo restraint products suitable for their specific applications. Because we continuously strive to offer new and improved products, part numbers and specifications are subject to change without notice. Please contact your Ancra Representative or our Customer Service Department for any new information.

WARRANTY

All Ancra Cargo products, unless otherwise indicated are warranted to be free from defect in material or workmanship for a period of six (6) months from date of shipment. During this period, Ancra Cargo will, at its option repair or replace without charge any products or part thereof found to be defective in material or workmanship. This warranty does not extend to any product which has been subject to misuse, abuse, negligence, accident, alteration or repair.

All Ancra Cargo SilverCap OverDrive product, unless otherwise indicated are warranted to be free from defect in material or workmanship for a period of twelve (12) months from date of shipment. During this period, Ancra Cargo will, at its option repair or replace without charge any product or part thereof found to be defective in material or workmanship. This warranty does not extend to any product which has been subject to misuse, abuse, negligence, accident, alteration or repair.

Ancra Cargo LAD II, RAR & or VAD systems, unless otherwise indicated are warranted to be free from defect in material or workmanship for a period of twenty-four (24) months from date of shipment. During this period, Ancra Cargo will, at its option repair or replace without charge any product or part thereof found to be defective in material or workmanship. This warranty does not extend to any product which has been subject to misuse, abuse, negligence, accident, alteration or repair.

Poly Deckboard and Ratchet Winches are warranted for a period of thirty-six (36) months from date of shipment. During this period, Ancra Cargo will, at its option repair or replace without charge any product or part thereof found to be defective in material or workmanship. This warranty does not extend to any product which has been subject to misuse, abuse, negligence, accident, alteration or repair.

Defective products must be returned to Ancra Cargo within the above period, transportation prepaid. Ancra will bear the cost of return transportation. Contact Customer Service for details.

THIS WARRANTY IS IN LIEU OF ALL OTHER WARRANTIES EXPRESSED OR IMPLIED INCLUDING BUT NOT LIMITED TO ANY IMPLIED WARRANTY OF MERCHANTABILITY OR FITNESS FOR ANY PARTICULAR PURPOSE. IN NO EVENT WILL ANCRA CARGO BE LIABLE FOR SPECIAL, INDIRECT OR CONSEQUENTIAL DAMAGES OR LOSS OF VEHICLE, CARGO OR PROFITS.

INDUSTRY STANDARDS

Ancra has provided the following information as a service to our customers. This information is intended to promote the safe and informed sales and use of our products.

ALL CARGO RESTRAINTS, INCLUDING SYNTHETIC WEB TIE DOWNS SHALL BE USED IN ACCORDANCE WITH ALL STATE, FEDERAL, PROVINCIAL, LOCAL AND INDUSTRY REGULATIONS, AS APPLICABLE.

U.S. Department of Transportation regulations subchapter B-Motor Carrier Safety Regulations, 49 CFR, Part 393, Paragraph 393.102(b) requires that: "The aggregate working load limit of the tie down assemblies used to secure an article against movement in any direction must be at least 1/2 times the weight of that article."

It is the owner's and user's responsibility to determine suitability of a product for any particular use. All strap assemblies or systems are as strong as their weakest component, including the point of attachment.

An example using this regulation follows:

- Determine the number of synthetic web tie downs required when using the Working Load Limit (WLL) value marked on the synthetic web tie down assembly.
- Weight of article being secured is 24,000 LB (10,910 KG).
- Working Load Limit of the 3-inch synthetic web tie down is 4,000 LB (1,820 kg) as marked on the label.
- Required Aggregate WLL
1/2 x 24,000 LB (Article Weight) = 12,000 LB (5,455 KG)
- Minimum number of tie downs
12,000 LB ÷ 4,000 LB (WLL of tie down) = 3 tie downs

In this example, a minimum of 3 synthetic web tie downs are required to secure the article, based only on the weight of the article.

Some factors to be considered when determining the number and location of synthetic web tie downs, as specified by applicable regulations are:

- Article weight
- Configuration of load to be secured (pipe, coil, equipment, stacking, etc.)
- Number of tiers
- Length of load to be secured
- WLL of synthetic web tie downs
- Stakes, blocking and bracing
- Tension in the synthetic tie down shall never exceed the WLL strength rating of anchorage.
- Any other factors that may affect safe securement of the load during normal and emergency conditions.
- Also see Ancra tie down calculator APP — its free.

Operating Guidelines

This section provides recommended guidelines for the use, care, and inspection of synthetic web tie downs.

Use

- Inspect tie downs before each use, see Out-Of-Service Criteria.
- Synthetic web tie down assemblies shall not be loaded in excess of their Working Load Limit (WLL).

- Synthetic web tie downs shall be attached to provide control of load and positioned in accordance with applicable regulations.
- Synthetic web tie down assemblies shall not be dragged on floor, ground, or over an abrasive surface.
- Synthetic web tie downs shall not be tied in knots, or joined by knotting.
- Synthetic web tie downs shall not be pulled from under loads if the load is resting on the tie down.
- Synthetic web tie downs shall always be protected from being cut by sharp corners, sharp edges, protrusions or abrasive surfaces.
- The opening in fittings shall have the required shape and size to insure that the fitting will sit properly in the vehicle anchorage or other attachments. If the anchorage is inadequate to support the rating of the synthetic web tie down assembly, then the load rating will be limited to the strength of the anchorage.
- Synthetic web tie downs shall not be used for lifting or towing. This includes raising, lowering and suspending.
- Before operating any tie down assembly, the user shall secure his footing to prevent slipping or falling.
- In freezing temperatures caution shall be exercised when operating frozen tie down assemblies.
- A minimum of two (2) wraps of webbing shall be on the winch or ratchet buckle mandrel. Caution: Excessive wraps of webbing on the mandrel will reduce the working load limit of the winch or ratchet buckle.

When tightening or loosening winches, always maintain a firm grip on the winch bar. Never release a winch bar without checking the pawl to ensure that it is fully engaged between ratchet teeth. Releasing a winch bar without the pawl being properly engaged can cause serious injury to the user or bystanders. The use of a slip resistant handle winch bar specifically designed to tighten or loosen winches is recommended. Only winch bars designed to be used with winches shall be used to tension and release the tie down.

"Cheater Bars" ("extenders") shall not be used with winch bars.

The user shall stand clear (to one side) of the winch bar handle during operation, in case the winch bar slips. The tip of the winch bar shall be inserted through both holes in the end cap to prevent the winch bar from "slipping out" and overloading the tip and/or end cap.

Synthetic web tie downs shall be used, checked and adjusted during the transportation of cargo per applicable federal, state, provincial, local and industry regulations.

Care

Environments in which synthetic web tie downs are continuously exposed to ultra-violet sunlight can affect the strength in varying degrees, ranging from slight to total degradation.

- Store in a clean, dry location out of direct sunlight.
- Avoid exposure to acids, alkalis or temperatures in excess of 194°F.

Inspection

Inspect equipment before each use. Do not use synthetic web tie downs that have excessive wear, cuts, abrasion or which have any other defect that should cause it to be pulled from service.

INDUSTRY STANDARDS

IT IS ULTIMATELY THE DRIVER'S RESPONSIBILITY TO INSURE THAT THE CARGO BEING HAULED IS PROPERLY SECURED. The U.S. Department of Transportation, Federal Motor Carrier Safety Administration regulation 49CFR Part 392.9(a) states: "A driver may not operate a commercial motor vehicle, and a motor carrier may not require or permit a driver to operate a commercial motor vehicle unless the commercial motor vehicle's cargo is properly distributed and adequately secured as specified in sections 393.100 through 393.142 of this subchapter." In addition, 49CFR Part 392.9(b) states: "Drivers of truck and truck tractors must assure himself/herself that the provisions of paragraph (a) of this section have been complied with before he/she drives that commercial motor vehicle; inspect the cargo and the devices used to secure the cargo within the first 50 miles after beginning a trip and cause any adjustments to be made to the cargo or load securement devices as necessary, including adding more securement devices, to ensure that cargo cannot shift on or within, or fall from the commercial motor vehicle; and reexamine the commercial motor vehicle's cargo and its load securement devices during the course of transportation and make any necessary adjustments to the cargo or load securement devices, including adding more securement devices, to ensure that the cargo cannot shift on or within, or fall from, the commercial motor vehicle."

CARE AND USE

INSPECT BEFORE USE – Do not use synthetic web tie downs if the webbing has excessive wear, is damaged, abraded or cut. Do not use if the hardware is damaged or defective. Do not use if there are knots in the webbing. Do not use if the WLL markings are not visible.

PROTECT FROM SHARP EDGES – Always use corner protectors or edge protectors to protect the straps when they are exposed to corners or abrasive or hot surfaces.

STORAGE – Store synthetic web tie downs in a clean dry place out of direct sunlight when not in use. Avoid exposure to acids, alkalis or temperatures in excess of 194 degrees F.

NOT FOR LIFTING OR TOWING – Do not use synthetic web tie down straps for lifting, lowering, suspending, recovery or towing. Use only properly marked and rated lifting slings for lifting, lowering or suspending applications and properly marked and rated recovery or tow straps for recovery or towing applications.

MODIFICATION OR MISUSE – Any modification or misuse of Ancra products will result in voiding of warranty and liability responsibility of Ancra Cargo.

WINCHES – Ancra cargo securement winches shall be installed, used and maintained in accordance with the information sheet provided with each winch. Ancra winches are designed to be used with Ancra winch bars inserted fully through the hole in the mandrel cap end. Do not use cheater bars or extenders on the Ancra winch bars.

WEBBING WRAPS – When using winch or ratchet straps, a minimum of two (2) and maximum of four (4) wraps of webbing shall be on the winch mandrel. Excessive wraps of webbing on the mandrel may reduce the working load limit (WLL) of the synthetic web tie down and may interfere with proper operation.

SECURE FOOTING – Before operating any synthetic web tie down assembly the user shall secure his footing to prevent slipping or falling. In adverse weather conditions, including freezing temperatures, additional caution should be exercised.

CAUTIONS AND WARNINGS – For the benefit of the user and the motoring public, each Ancra product is provided with instructions including cautions and warnings associated with its use. Failure to comply may result in personal injury, property damage or death.

RECOMMENDED OPERATING PRACTICES for SYNTHETIC WEB TIE DOWNS

These guidelines are not intended to replace proper training, experience and learned knowledge regarding proper tie down procedures.

SELECTION – Select a synthetic web tie down having suitable characteristics for the type of load, environment and attachment to vehicle anchor point. Fittings shall have the required shape and size to attach properly to the vehicle anchor points.

WORKING LOAD LIMIT – Identify the working load limit (WLL) marked on the synthetic web tie down by the manufacturer. If the required markings are illegible or missing, remove from service. Read all warnings and/or instructions provided by the manufacturer.

ANCHOR POINTS – Identify the working load limit (WLL) of the vehicle anchor points. If no rating is visible, contact the vehicle manufacturer for tie down instructions. The lesser-rated WLL, whether the anchor point or the synthetic web tie down, shall determine the WLL of the securement system.

NUMBER OF TIE DOWNS – Determine the proper number of synthetic web tie downs required based on the weight of the cargo, the type of commodity, the aggregate working load limit of the securement system and the length/weight ratio of the cargo being secured. Additionally, end users and enforcement personnel are required to know commodity-specific rules governing proper tie down determination as published by the Federal Motor Carrier Safety Administration Standard for Protection Against Shifting and Falling Cargo; Final Rule effective December 26, 2002.

OUT-OF-SERVICE CRITERIA (REPLACEMENT)

Synthetic web tie downs shall be removed from service if any of the following are visible:

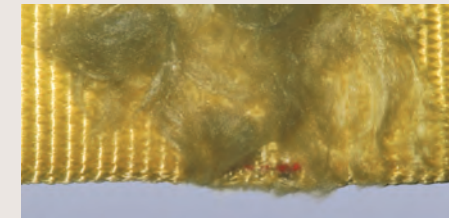

Excessive abrasive wear

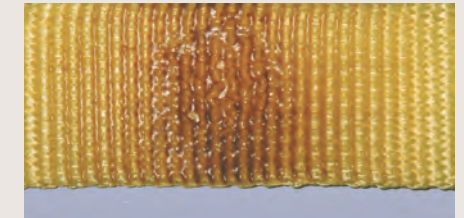

Melting or charring of the tie down, or weld splatter on the tie down

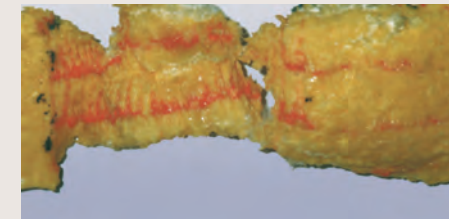

Chemical burns

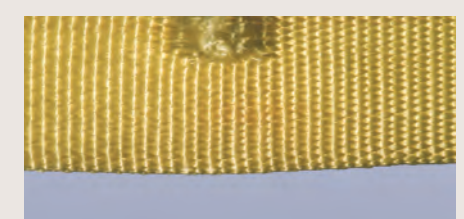

Holes, tears, cuts, snags

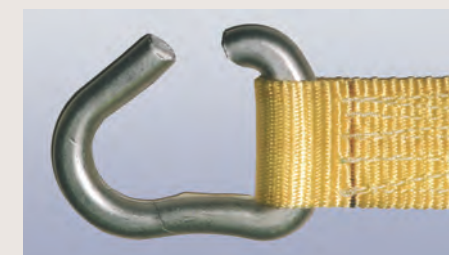

Tear in webbing or fitting

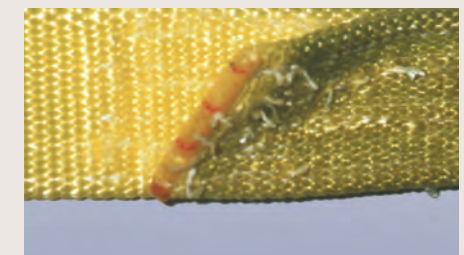

Broken or worn stitching in load bearing sew patterns

GLOSSARY

Abrasion	The mechanical wearing of a surface from contact with other object.
Aggregate Working Load Limit	The summation of the Working Load Limit (WLL) of all tie downs used to secure an article of cargo.
Anchor Point	The location to which a tie down is attached to a vehicle or article of cargo. If the anchor point is inadequate to support the force of the tie down system, then the load rating of the tie down will be limited to the strength of the anchor point.
Breaking Strength	The tensile load in pounds or kilograms at which any part of the securement assembly fails.
Cargo	All articles or material carried by a vehicle, including those used in operation of the vehicle.
Design Factor	The ratio of the breaking strength to the Working Load Limit (WLL).
Direct Tie Down	A tie down that is attached directly to the cargo.
Elongation	The measurement of stretch at a specifically applied load, expressed as a percentage of the original length.
Fabrication Efficiency	The synthetic web tie down assembly break strength, as a percentage of the webbing strength prior to fabrication.
Indirect Tie Down	A tie down which passes over the cargo and is secured to the vehicle at both ends. Tension in the tie down increases the pressure of an article or stack of articles on the deck of the vehicle.
Keeper	A device used on a hook to prevent the hook from inadvertently releasing.
Length	The distance between extreme end bearing points of the synthetic web tie down assembly, including the fittings.
Lever Load Binder	A chain binder incorporating an overcenter locking action.
Proof Load Test	A non-destructive load test to some multiple of the working load limit.
Selvage	The woven or knitted edge of synthetic webbing.
Sew/Stitch Pattern	The pattern of the stitches used to sew the webbing together.
Shoring Bar	A structural bar placed transversely between the walls of a vehicle to prevent cargo from tipping or shifting.
Ultimate Test	A load test of a securement assembly tested to failure.
Warp	A longitudinal load bearing yarn in webbing.
Winch	A device for tensioning a webbing or wire rope tie down that is fitted with means to lock the initial tension.
Working Load Limit (WLL)	The maximum load a component or assembly should be subjected to during routine use.

INNOVATIVE TEAMWORK SOLUTIONS

- ▶ **When we start a project with you, we develop shared objectives based on your specific goals.** We view your requirements from all angles. With over decades of industry experience, we don't automatically reach for the easy answers. The innovative solutions we've developed are a result of looking at each new project from a fresh perspective.
- ▶ We envision the global picture, and we sweat the details. Each part is tested and tested again against the highest standards of quality, reliability and durability.
- ▶ Through every step of the process, we work as a team with you. We continue to provide technical support after our products have been installed.

TRADE ASSOCIATIONS

	Web Sling & Tie Down Association (WSTDA)		Associated Wire Rope Fabricators (AWRF)
	British Columbia Trucking Association (BCTA)		Commercial Vehicle Safety Alliance (CVSA)
	Technology & Maintenance Council (TMC)		Association of American Railroads (AAR)
	Truck Trailer Manufacturers Association (TTMA)		National Trailer Dealers Association (NTDA)
	Canadian Transportation Equipment Association (CTEA/AETC)		National Association of Trailer Manufacturers (NATM)
	Commercial Vehicle Safety Network (CVSN)		Heavy Duty Distributor Council (HDDC)
	Air Forwarders Association (AFA)		American Moving & Storage Association (AMSA)
			National Private Truck Council (NPTC)

STATE TRUCKING ASSOCIATIONS

- ▶ Arkansas Trucking Association
- ▶ Alabama Trucking Association
- ▶ Indiana Motor Truck Association
- ▶ Minnesota Trucking Association
- ▶ New Jersey Motor Truck Association
- ▶ Ohio Trucking Association
- ▶ Pennsylvania Motor Truck Association
- ▶ Texas Motor Transportation Association
- ▶ Tennessee Trucking Association
- ▶ Washington Trucking Association
- ▶ Wisconsin Motor Carrier Association

LITERATURE AVAILABLE BY REQUEST

		
Ankra Cargo Aircraft Interiors & Cargo Fittings This catalog provides a full selection of the very best aircraft fittings and components, all made in the U.S.A. by Ancra for over 25 years. Request Catalog 402	Ankra Cargo Cargo Restraint Catalog Ancra showcases the most popular solutions for flatbed and interior van cargo restraints. A mini catalog of winches, straps, tie-offs, beams and bars. Request Brochure 221	Ankra Cargo Lift-A-Deck II Ancra's proprietary Lift-A-Deck decking systems enables optimum utilization of cargo space in vans and trailers. Request Brochure B-254

INDEX BY PRODUCT NUMBER

10135	Overcenter Buckle - 2"- 3,000 lbs. WLL	20-EE1-9802X14	2" x 14' Eye/Eye 1 Ply Sling	81
10632-90	2" x 18" Fixed End Strap w/ 44587-10	20-EE2-9801X4	1" x 4' Eye/Eye 2 Ply Sling	82
	Buckle & 40891-18 Flat Hook	20-EE2-9801X8	1" x 8' Eye/Eye 2 Ply Sling	82
10632-90-28	2" x 28' Adjustable End Strap w/ 40891-18	20-EE2-9802X3	2" x 3' Eye/Eye 2 Ply Sling	82
	Flat Hook	20-EE2-9802X4	2" x 4' Eye/Eye 2 Ply Sling	82
10632-93	2" x 33" Fixed End Strap w/ 44587-10	20-EE2-9802X6	2" x 6' Eye/Eye 2 Ply Sling	82
	Buckle & 43366-21 Chain Anchor	20-EE2-9802X8	2" x 8' Eye/Eye 2 Ply Sling	82
10632-93-28	2" x 28' Adjustable End Strap w/ 43366-21	20-EE2-9802X10	2" x 10' Eye/Eye 2 Ply Sling	82
	Chain Anchor	20-EE2-9802X12	2" x 12' Eye/Eye 2 Ply Sling	82
10632-95	2" x 18" Fixed End Strap w/ 44587-10	20-EE2-9802X16	2" x 16' Eye/Eye 2 Ply Sling	82
	Buckle & 43120-13 Wire Hook	20-EE2-9802X20	2" x 20' Eye/Eye 2 Ply Sling	82
10632-95-28	2" x 28' Adjustable End Strap w /43120-13	20-EE2-9802X30	2" x 30' Eye/Eye 2 Ply Sling	82
	Wire Hook	20-EE2-9803X10	3" x 10' Eye/Eye 2 Ply Sling	82
10633-90	3" x 18" Fixed End Strap w/ 48965-10	20-EE2-9803X12	3" x 12' Eye/Eye 2 Ply Sling	82
	Buckle & 41766-18 Flat Hook	20-EE2-9803X16	3" x 16' Eye/Eye 2 Ply Sling	82
10633-90-28	3" x 28' Adjustable End Strap w/ 41766-18	20-EE2-9803X20	3" x 20' Eye/Eye 2 Ply Sling	82
	Flat Hook	20-EE2-9804X6	4" x 6' Eye/Eye 2 Ply Sling	82
10633-92	3" x 33" Fixed End Strap w/ 48965-10	20-EE2-9804X8	4" x 8' Eye/Eye 2 Ply Sling	82
	Buckle & 43366-14 Chain Anchor	20-EE2-9804X10	4" x 10' Eye/Eye 2 Ply Sling	82
10633-92-28	3" x 28' Adjustable End Strap w/ 43366-14	20-EE2-9804X12	4" x 12' Eye/Eye 2 Ply Sling	82
	Chain Anchor	20-EE2-9804X16	4" x 16' Eye/Eye 2 Ply Sling	82
10634-90	4" x 18" Fixed End Strap w/ 49349-10	20-EE2-9804X20	4" x 20' Eye/Eye 2 Ply Sling	82
	Buckle & 41766-18 Flat Hook	20-ENR1X3	1" x 3' Purple Endless Round Sling	80
10634-90-28	4" x 28' Adjustable End Strap w/ 41766-18	20-ENR1X4	1" x 4' Purple Endless Round Sling	80
	Flat Hook	20-ENR1X6	1" x 6' Purple Endless Round Sling	80
10634-91	4" x 33" Fixed End Strap w/ 49349-10	20-ENR1X8	1" x 8' Purple Endless Round Sling	80
	Buckle & 43366-14 Chain Anchor	20-ENR1X12	1" x 12' Purple Endless Round Sling	80
10634-91-28	4" x 28' Adjustable End Strap w/ 43366-14	20-ENR2X3	2" x 3' Green Endless Round Sling	80
	Chain Anchor	20-ENR2X4	2" x 4' Green Endless Round Sling	80
10634-93	4" x 20" Fixed End Strap w/ 49349-10	20-ENR2X8	2" x 8' Green Endless Round Sling	80
	Buckle & 43120-20 Wire Hook	20-ENR2X12	2" x 12' Green Endless Round Sling	80
10634-93-28	4" x 28' Adjustable End Strap w/ 43120-20	20-ENR2X20	2" x 20' Green Endless Round Sling	80
	Wire Hook	20-ENR3X3	3" x 3' Yellow Endless Round Sling	80
10788-10	Door Pull Strap	20-ENR3X4	3" x 4' Yellow Endless Round Sling	80
10865-11	100" Wide x 90.5" Tall Cargo Net	20-ENR3X8	3" x 8' Yellow Endless Round Sling	80
10924-10	Trailer Door Limit Strap	20-ENR3X12	3" x 12' Yellow Endless Round Sling	80
10902-11	Driver Assist Strap	20-ENR3X20	3" x 20' Yellow Endless Round Sling	80
10939-10	Gear Drive Tensioner Snap Hook	20-ENR4X10	4" x 10' Tan Endless Round Sling	80
10939-12	Gear Drive Tensioner Flat Hook	20-ENR4X16	4" x 16' Tan Endless Round Sling	80
20-EE1-9801X3	1" x 3' Eye/Eye 1 Ply Sling	20-ENR5X4	5" x 5' Red Endless Round Sling	80
20-EE1-9801X4	1" x 4' Eye/Eye 1 Ply Sling	20-ENR5X6	5" x 6' Red Endless Round Sling	80
20-EE1-9801X6	1" x 6' Eye/Eye 1 Ply Sling	20-ENR5X12	5" x 12' Red Endless Round Sling	80
20-EE1-9801X10	1" x 10' Eye/Eye 1 Ply Sling	20-ENR5X20	5" x 20' Red Endless Round Sling	80
20-EE1-9802X3	2" x 3' Eye/Eye 1 Ply Sling	20-ENR7X6	7" x 7' Blue Endless Round Sling	80
20-EE1-9802X4	2" x 4' Eye/Eye 1 Ply Sling	30AS33-BK	2" x 33" Black Axle Strap w/ Sleeve	77
20-EE1-9802X6	2" x 6' Eye/Eye 1 Ply Sling	30ATB	Adjustable Tire Bonnet	78
20-EE1-9802X10	2" x 10' Eye/Eye 1 Ply Sling	30RT	Double Adjustable Tire Bonnet	78
20-EE1-9802X12	2" x 12' Eye/Eye 1 Ply Sling	310R-120	Galvanized Steel Tether Track	57

INDEX BY PRODUCT NUMBER

40023-12	Wire Hook, Wide - 2"- 833 lbs. WLL	40838-10	Series E Vertical Track (Gray) 10'	55
40024-10	Wire Hook, Narrow - 1"- 1,000 lbs. WLL	40838-11	Series E Vertical Track (Galvanized) 10'	55
40024-12	Wire Hook, Narrow - 2"- 833 lbs. WLL	40849-12	Series F Track (Galvanized) 10', 1" Holes	
40025-10	D-Ring - 1"- 1,666 lbs. WLL		Canada	56
40025-12	D-Ring - 2"- 1,666 lbs. WLL	40849-14	Series F Track (Galvanized) 10', 1.62"	
40044-10	Flat Hook w/ Keeper - 1"- 1,166 lbs. WLL		Hole Spacing	56
40065-10	Flat Hook - 1"- 333 lbs. WLL	40880-15	Cam Buckle - 2"- 833 lbs. WLL	
40065-12	Flat Hook, Vinyl - 1"- 333 lbs. WLL		Replaces 40880-19	91
40084-14	Snap Hook - 2"- 2,100 lbs. WLL	40880-22	Cam Buckle - 1"- 600 lbs. WLL	91
40316-12	Wire Hook, Narrow - 1"- 166 lbs. WLL	40891-18	Flat Hook - 2"- 3,333 lbs. WLL	93
40340-27	Single Stud Track Fitting - 1,333 lbs.	40921-10	Beam Socket	59
	Vertical WLL	40921-11	Beam Socket Heavy-Duty	59
40386-10	Rope Tie Off - Series E (3 piece End Fitting)	40978-11	Delta Ring - 2"- 3,333 lbs. WLL	94
	1,000 lbs. WLL	40980-11	Track Fitting Series F - 500 lbs. WLL	96
40386-11	Rope Tie Off - Series E (Spring Actuated Fitting)	40980-13	Track Fitting Series F - 500 lbs. WLL (Canada)	96
	1,333 lbs. WLL	40985-05-12	Web Protector - Cordura Sleeve - 12" Long	17
40386-12	Rope Tie Off - Series F - 500 lbs. WLL	40985-05-RL	Web Protector - Cordura Sleeve - 100 Yd. Roll	17
40386-13	Rope Tie Off - Series F - 500 lbs. WLL (Canada)	41030-12	Cam Buckle - 1"- 166 lbs. WLL	
40467-33-144	Heavy-Duty Aircraft Track 12'		Replaces 41030-10	91
40602-10	Series E Strap Assy - 3-pc. End - 12'	41048-10	Ancra Red Motorcycle Strap - 1" x 5.5'	82
40602-11	Series E Strap Assy - 3-pc. End - 16'	41048-23	Ancra Red Motorcycle Strap - 1" x 13'	82
40602-12	Series E Strap Assy - 3-pc. End - 20'	41313-12	S Hook, Plated - 1"- 400 lbs. WLL	92
40602-17	Series E Strap Assy - 1-pc. End - 12'	41313-13	S Hook, Vinyl - 1"- 400 lbs. WLL	92
40602-18	Series E Strap Assy - 1-pc. End - 16'	41313-19	S Hook, Vinyl - 1"- 600 lbs. WLL	92
40602-19	Series E Strap Assy - 1-pc. End - 20'	41325-10	Slat Hook - 1,000 lbs. WLL	96
40602-20	Series F Strap Assembly - Cam Buckle - 12'	41409-13	Series E End Fitting (3 Piece) 1,000 lbs. WLL	20
40602-21	Series F Strap Assembly - Cam Buckle - 16'	41516-11	Corner Protector - 2"- Aluminum	17
40602-22	Series F Strap Assembly - Cam Buckle - 20'	41572-10	Replacement Hooks for Tarp Ties - 100-pc. Bag	19
40602-97	Plate Trailer Strap Assembly w/ Wire Hooks -	41631-12	Delta Ring - 4"- 6,666 lbs. WLL	94
	Cam Buckle - 12'	41632-17-BULK-CUT	3" Yellow Polyester Latex Treated Webbing	101
40602-98	Plate Trailer Strap Assembly w/ Wire Hooks -	41632-19-BULK-CUT	2" Red Polyester Latex Treated Webbing	101
	Cam Buckle - 16'	41632-24-BULK-CUT	3" Blue Polyester Latex Treated Webbing	101
40602-99	Plate Trailer Strap Assembly w/ Wire Hooks -	41632-26-BULK-CUT	2" Blue Polyester Lated Treated Webbing	101
	Cam Buckle - 20'	41632-31-BULK-CUT	2" Yellow Polyester Latex Treated Webbing	101
40602-100	LAD II Logistics Strap w/ Single Stud Fitting -	41645-10	Roller Buckle - 2"- 500 lbs. WLL	91
	Cam Buckle - 12'	41659-10-27	2" x 27' Winch Strap w/ 40891-18 Flat Hook	31
40602-101	LAD II Logistics Strap w/ Single Stud Fitting -	41659-10-30	2" x 30' Winch Strap w/ 40891-18 Flat Hook	31
	Cam Buckle - 16'	41659-11-27	2" x 27' Winch Strap w/ 40978-11 Delta Ring	31
40602-102	LAD II Logistics Strap w/ Single Stud Fitting -	41659-11-30	2" x 30' Winch Strap w/ 40978-11 Delta Ring	31
	Cam Buckle - 20'	41659-13-27	2" x 27' Winch Strap w/ 43120-13 Wire Hook	31
40602-103	Series F Strap Assembly - Cam Buckle - 12' -	41659-13-30	2" x 30' Winch Strap w/ 43120-13 Wire Hook	31
	Canada	41659-15-27	2" x 27' Winch Strap w/ 43366-21	
40602-104	Series F Strap Assembly - Cam Buckle - 16' -		Chain Anchor	31
	Canada	41659-15-30	2" x 30' Winch Strap w/ 43366-21	
40602-105	Series F Strap Assembly - Cam Buckle - 20' -		Chain Anchor	31
	Canada	41659-16-30	2" x 30' Winch Strap w/o Hardware	31
40758-11	Snap Hook, Twisted - 2"- 3,333 lbs. WLL	41659-90-27	2" x 27' ANCRA X-TREME Winch Strap	
40758-13	Snap Hook - 2"- 3,333 lbs. WLL		w/ 40891-18 Flat Hook	27

INDEX BY PRODUCT NUMBER

41659-90-30	2" x 30' ANCRA X-TREME Winch Strap w/ 40891-18 Flat Hook 27	43099-10	Flat Hook - 2" - 1,666 lbs. WLL 93
41659-92-30	2" x 30' ANCRA X-TREME Winch Strap w/ 43120-13 Wire Hook 27	43120-11	Wire Hook, Narrow - 2" - 1,666 lbs. WLL 92
41659-93-30	2" x 30' ANCRA X-TREME Winch Strap w/ 43366-21 Chain Anchor 27	43120-13	Wire Hook, Narrow - 2" - 3,333 lbs. WLL 92
41659-94-30	2" x 30' ANCRA X-TREME Winch Strap w/o Hardware 27	43120-19	Wire Hook, Narrow - 1.75" - 500 lbs. WLL 92
41660-10-27	3" x 27' Winch Strap w/ 41766-18 Flat Hook 32	43120-20	Wire Hook, Narrow - 3" - 7,333 lbs. WLL 92
41660-10-30	3" x 30' Winch Strap w/ 41766-18 Flat Hook 32	43320-32	Ratchet Buckle - 1" - 1,466 lbs. WLL 88
41660-14-27	3" x 27' Winch Strap w/ 43366-14 Chain Anchor 32	43365-12	Grab Hook Assembly, Unplated - 5,400 lbs. WLL 98
41660-14-30	3" x 30' Winch Strap w/ 43366-14 Chain Anchor 32	43366-14	Chain Anchor w/ Delta Ring - 5,400 lbs. WLL 97
41660-17-30	3" x 30' Winch Strap w/o Hardware 32	43366-21	5/16" Chain Anchor w/ Delta Ring - 3,333 lbs. WLL 97
41660-18-27	3" x 27' Winch Strap w/ 43120-20 Wire Hook 32	43488-20	Combo Winch - Side Mount - Low Profile 7
41660-18-30	3" x 30' Winch Strap w/ 43120-20 Wire Hook 32	43546-10	Gutter Hook - 1" - 250 lbs. WLL 93
41660-90-30	3" x 30' ANCRA X-TREME Winch Strap w/ 41766-18 Flat Hook 29	43563-10	Web Winch - Bottom Mount - Std. 2
41660-93-30	3" x 30' ANCRA X-TREME Winch Strap w/ 43366-14 Chain Anchors 29	43563-10-RW	Web Winch - Bottom Mount - Std. Weld-on 2
41660-95-30	3" x 30' ANCRA X-TREME Winch Strap w/o Hardware 29	43564-12	Web Winch - Bottom Mount - Std. Storable Portable w/ 2SS 2
41681-10	Combo Winch - Bottom Mount - Std. 7	43564-147	Web Winch - Bottom Mount - Std. Portable w/ 2SS w/ 7mm Frame 2
41691-10	Web Winch - Frameless 3	43564-147-RW	Web Winch - Bottom Mount - Std. Portable Ratcheting 2
41696-10	Cable Winch - End Mount - RH 7	43564-167	Web Winch - Side Mount - Low Profile Portable w/ 2SS 2
41696-11	Cable Winch - End Mount - LH 7	43565-127	Web Winch - Bottom Mount - Storable C Track Slider w/ 7mm Frame 3
41766-18	Flat Hook - 3" - 5,400 lbs. WLL 93	43565-127-RW	Web Winch - Bottom Mount - Storable Web C Track Slider 3
41766-19	Flat Hook - 3" - 5,400 lbs. WLL w/ Keeper 93	43565-127-XZ	Web Winch - Bottom Mount - Deep Storable C Track Slider - X-Treme Zinc Finish 3
41808-14	Ratchet Buckle - 1 3/4" - 2,000 lbs. WLL 88	43565-137	Web Winch - Bottom Mount - C Track Slider - Double Cap w/ 7mm Frame 3
41820-10-RL	1" Red Nylon Webbing 101	43565-14	Web Winch - Bottom Mount - Storable C Track Slider w/ 7mm Frame 3
41820-14-RL	1" Blue Nylon Webbing 101	43565-157	Web Winch - Bottom Mount - Std. C Track Slider w/ 7mm Frame 4
41820-15-RL	1" Black Nylon Webbing 101	43565-157-RW	Web Winch - Bottom Mount - Std. C Track Slider Ratcheting 4
42012-12 HD	Series F Hook - 800 lbs. WLL 96	43565-157-XZ	Web Winch - Bottom Mount - Std. C Track Slider - X-Treme Zinc Finish 4
42098-11	Corner Protector - 3" - Rubber 17	43573-10	Web Winch - Bottom Mount - Std. Storable 2
42098-12	Corner Protector - 4" - Rubber 17	43573-13	Web Winch - Bottom Mount - Std. Storable 4" Spool 2
42195-11	Cam Buckle - 1" - 500 lbs. WLL Replaces 42195-10 91	43579-20	Web Winch - Side Mount - Low Profile 3
42313-10	Winch Bar - Std. Painted 14	43627-13	Replacement Channel Assembly (Al. Beam) 59
42313-12	Winch Bar - Combination Box End Painted Silver & Yellow 14	43638-50	Decking/Shoring Beam Series E - 85.7" - 96.6" Long 58
42313-17	Winch Bar - Std. Chrome 14	43638-51	Decking/Shoring Beam Series E - 91.9" - 102.9" Long 58
42313-19	Winch Bar - Combination Chrome 14		
42357-11	Winch Track - 6' Steel 11		
42357-12	Winch Track - 12' Steel 11		
42357-21	Winch Track - 6' Aluminum 11		
42816-18	Overcenter Buckle - 1" - 600 lbs. WLL 90		
42948-10	Series A Horizontal Track (Gray) 10' 56		
43044-10	Snap Hook - 1" - 1,666 lbs. WLL 94		

INDEX BY PRODUCT NUMBER

43781-145	Long Foot Assembly (2 x 4) 60	43795-95-30	4" x 30' ANCRA X-TREME Winch Strap w/ 43366-14 Chain Anchor 30
43781-155	Short Foot Assembly (2 x 4) 60	43797-18-BULK-CUT	4" Gray Polyester Latex Treated Webbing 101
43781-16	Long Foot Assembly (4 x 4) 60	43797-19-BULK-CUT	4" Blue Polyester Latex Treated Webbing 101
43781-17	Short Foot Assembly (4 x 4) 60	43797-23-BULK-CUT	4" Red Polyester Latex Treated Webbing 101
43782-15	Cargo Sta - Standard - 89.75" to 104.5" Long 60	43797-34-BULK-CUT	4" Green Polyester Latex Treated Webbing 101
43795-10-27	4" x 27' Winch Strap w/ 41766-18 Flat Hook 32	43797-36-RL	4" Yellow Polyester Latex Treated Webbing 101
43795-10-30	4" x 30' Winch Strap w/ 41766-18 Flat Hook 32	43887-10	Mini Ratchet Strap - 1" x 16' - Display Packaged 84
43795-10-35	4" x 35' Winch Strap w/ 41766-18 Flat Hook 32	43887-11	Mini Ratchet Strap - 1" x 20' - Display Packaged 84
43795-10-40	4" x 40' Winch Strap w/ 41766-18 Flat Hook 32	43887-15	Mini Ratchet Strap - 1" x 9' - Display Packaged 84
43795-10-50	4" x 50' Winch Strap w/ 41766-18 Flat Hook 32	43908-10	Combo Winch - Recessed Box 7
43795-11-27	4" x 27' Winch Strap w/ 41631-12 Delta Ring 32	43986-10	Corner Protector - 4" - Black Plastic 17
43795-11-30	4" x 30' Winch Strap w/ 41631-12 Delta Ring 32	43991-10	Hoop Set - Cargo Sta 60
43795-11-35	4" x 35' Winch Strap w/ 41631-12 Delta Ring 32	43997-10	Combo Winch - Leg Mount - Low Profile 7
43795-11-40	4" x 40' Winch Strap w/ 41631-12 Delta Ring 32	44102-11	H-2 Hook 15
43795-11-50	4" x 50' Winch Strap w/ 41631-12 Delta Ring 32	44122-10	Corner Iron Hook 15
43795-13-30	4" x 30' Winch Strap w/ Half Twisted Loop 32	44232-10	Ratchet Buckle - 1" - 400 lbs. WLL 88
43795-13-45	4" x 45' Winch Strap w/ Half Twisted Loop 32	44258-13	Ratchet Buckle - 2" - 1,500 lbs. WLL - Low Profile 89
43795-13-50	4" x 50' Winch Strap w/ Half Twisted Loop 32	44340-11	Strap Assy - 1" - Ratchet Buckle - 10' w/ Wire Hooks 84
43795-13-65	4" x 65' Winch Strap w/ Half Twisted Loop 32	44557-10	Ancra Lash R/B Strap - 1" x 15' - Bulk - 400 lbs. WLL 84
43795-13-75	4" x 75' Winch Strap w/ Half Twisted Loop 32	44587-10	Ratchet Buckle - 2" - 3,666 lbs. WLL - Long Wide Handle 89
43795-14-27	4" x 27' Winch Strap w/ 43365-12 Grab Hook 32	44627-11	Ratchet Buckle - 2" - 3,333 lbs. WLL - Standard Handle 89
43795-14-30	4" x 30' Winch Strap w/ 43365-12 Grab Hook 32	44639-12	Overcenter Buckle - 1 3/4" - 1,666 lbs. WLL 90
43795-15-27	4" x 27' Winch Strap w/ 43366-14 Chain Anchor 33	45143-20	Basket Strap for Tires 7"W x 20"H 77
43795-15-30	4" x 30' Winch Strap w/ 43366-14 Chain Anchor 33	45143-22	Basket Strap for Tires 8"W x 24"H 77
43795-19-30	4" x 30' Winch Strap w/o Hardware 33	45228-10	Rave Hook - 1,167 lbs. WLL 92
43795-40-30	4" x 30' Winch Strap w/ 41766-18 Flat Hook - Blue Webbing 33	45515-10	Cluster Hook (RTJ) 98
43795-60-30	4" x 30' Winch Strap w/ 41766-18 Flat Hook - Red Webbing 33	45545-15	Pan Fitting w/ Black Trim Collar 63
43795-90-27	4" x 27' ANCRA X-TREME Winch Strap w/ 41766-18 Flat Hook 30	45801-10	Web Winder 15
43795-90-30	4" x 30' ANCRA X-TREME Winch Strap w/ 41766-18 Flat Hook 30	45849-15	Recessed Pan Fitting 1,666 lbs. WLL 63
43795-90-40	4" x 40' ANCRA X-TREME Winch Strap w/ 41766-18 Flat Hook 30	45880-10	G70 Chain - 5/16" Bulk 4,700 lbs. WLL 400' Barrel 21
43795-91-27	4" x 27' ANCRA X-TREME Winch Strap w/ 41631-12 Delta Ring 30	45880-11	G70 Chain - 3/8" Bulk 6,600 lbs. WLL 200' Barrel 21
43795-91-30	4" x 30' ANCRA X-TREME Winch Strap w/ 41631-12 Delta Ring 30	45880-12	G70 Chain - 1/4" Bulk 3,150 lbs. WLL 400' Barrel 21
43795-91-40	4" x 40' ANCRA X-TREME Winch Strap w/ 41631-12 Delta Ring 30	45880-13	G70 Chain - 1/2" Bulk 11,300 lbs. WLL 100' Barrel 21
43795-92-30	4" x 30' ANCRA X-TREME Winch Strap w/o Hardware 30	45881-10-16	G70 Chain Assy - 5/16" x 16' w/ Clevis Hooks 4,700 lbs. WLL 21
43795-93-30	4" x 30' ANCRA X-TREME Winch Strap w/ Half Twist 30	45881-10-16-SP	G70 Chain Assy - 5/16" x 16' w/ Clevis Hooks 4,700 lbs. WLL - In Pail 22
		45881-10-20	G70 Chain Assy - 5/16" x 20' w/ Clevis Hooks 4,700 lbs. WLL 21
		45881-10-20-SP	G70 Chain Assy - 5/16" x 20' w/ Clevis Hooks 4,700 lbs. WLL - In Pail 22

INDEX BY PRODUCT NUMBER

45881-10-25	G70 Chain Assy - 5/16" x 25' w/ Clevis Hooks 4,700 lbs. WLL 21	45982-11-30-WK	2" x 30' Ratchet Strap w/ 40891-18 Flat Hooks, w/ Web Keeper Buckle. 38
45881-10-25-SP	G70 Chain Assy - 5/16" x 25' w/ Clevis Hooks 4,700 lbs. WLL - In Pail 22	45982-15	2" x 27' Ratchet Strap w/ 43366-21 Chain Anchors 36
45881-11-16	G70 Chain Assy - 3/8" x 16' w/ Clevis Hooks 6,600 lbs. WLL 21	45982-19	2" x 27' Ratchet Strap w/ 40758-11 Snap Hooks 36
45881-11-16-SP	G70 Chain Assy - 3/8" x 16' w/ Clevis Hooks 6,600 lbs. WLL - In Pail 22	45982-34	2" x 30' Ratchet Strap w/ 43366-21 Chain Anchors 36
45881-11-20	G70 Chain Assy - 3/8" x 20' w/ Clevis Hooks 6,600 lbs. WLL 19	45982-36	2" x 30' Ratchet Strap w/ 40758-11 Snap Hooks 36
45881-11-20-SP	G70 Chain Assy - 3/8" x 20' w/ Clevis Hooks 6,600 lbs. WLL - In Pail 20	45982-42	2" x 27' Ratchet Strap w/ 43120-13 Wire Hooks. 36
45881-11-25	G70 Chain Assy - 3/8" x 25' w/ Clevis Hooks 6,600 lbs. WLL 21	45982-43	2" x 30' Ratchet Strap w/ 43120-13 Wire Hooks. 34
45881-11-25-SP	G70 Chain Assy - 3/8" x 25' w/ Clevis Hooks 6,600 lbs. WLL - In Pail 22	45982-43-30-WK	2" x 30' Ratchet Strap w/ 43120-13 Wire Hooks, w/ Web Keeper Buckle. 38
45881-13-20	G70 Chain Assy - 1/2" . x 20' w/ Clevis Hooks 11,300 lbs. WLL 21	45982-90-27	2" x 27' Ratchet Strap w/ 40891-18 Flat Hooks. 32
45881-13-25	G70 Chain Assy - 1/2" . x 25' w/ Clevis Hooks 11,300 lbs. WLL 21	45982-90-27-WK	2" x 27' Ratchet Strap w/ 40891-18 Flat Hooks, w/ Web Keeper Buckle. 38
45943-10	Chain Load Binder - 5/16" Lever 5,400 lbs. WLL 26	45982-90-30	2" x 30' Ratchet Strap w/ 40891-18 Flat Hooks. 34
45943-10-HD	Chain Load Binder, Heavy-Duty - 5/16" Lever 5,400 lbs. WLL 26	45982-90-30-WK	2" x 30' Ratchet Strap w/ 40891-18 Flat Hooks, w/ Web Keeper Buckle. 38
45943-11	Chain Load Binder - 3/8" Lever 9,200 lbs. WLL 26	45982-93-30	2" x 30' Ratchet Strap w/ 43366-21 Chain Anchors 34
45943-12	Chain Load Binder - 1/4" Lever 2,500 lbs. WLL 26	45982-95-27	2" x 27' Ratchet Strap w/ 43120-13 Wire Hooks. 34
45943-13	Chain Load Binder - 1/2" Lever 13,000 lbs. WLL 26	45982-95-27-WK	2" x 27' Ratchet Strap w/ 43120-13 Wire Hooks, w/ Web Keeper Buckle. 38
45943-14	Recoilless Chain Load Binder - 5/16" Lever 5,400 lbs. WLL 26	45982-95-30	2" x 30' Ratchet Strap w/ 43120-13 Wire Hooks. 34
45943-20	Chain Load Binder - 5/16" Ratchet 5,400 lbs. WLL 27	45982-95-30-WK	2" x 30' Ratchet Strap w/ 43120-13 Wire Hooks, w/ Web Keeper Buckle. 38
45943-20-HD	Chain Load Binder, Heavy-Duty - 5/16" Ratchet 5,400 lbs. WLL 27	47105-11	Ratchet Buckle - 2" - 3,666 lbs. WLL - Short Wide Handle. 89
45943-21	Chain Load Binder - 3/8" Ratchet 9,200 lbs. WLL 27	47200-60-BULK-CUT	2" Gray Polyester Webbing 101
45943-23	Chain Load Binder - 1/2" Ratchet 13,000 lbs. WLL 27	47200-61-BULK-CUT	2" Yellow Polyester Webbing. 101
45946-10	5/16" Clevis Hook 4,700 lbs. WLL 23, 98	47200-62-BULK-CUT	2" Blue Polyester Webbing. 101
45946-11	3/8" Clevis Hook 6,600 lbs. WLL 23, 98	47200-64-BULK-CUT	2" Red Polyester Webbing 101
45946-12	1/4" Clevis Hook 3,150 lbs. WLL 23, 98	47235-10	Series F Channel - 10' (1" Hole Spacing) 57
45946-13	1/2 in. Clevis Hook 11,300 lbs. WLL. 23, 98	47556-11	Double Stud Fitting - 1,666 lbs. WLL 102
45951-12	Flat Latch Repair Kit 57	47608-21	Series E Track Fitting - 1,333 lbs. WLL 96
45982-10	2" x 27' Ratchet Strap w/ 40891-18 Flat Hooks . . 36	47640-31	Lashing Winch - 3,333 lbs. w/ Double Hex Drive 8, 78
45982-11	2" x 30' Ratchet Strap w/ 40891-18 Flat Hooks. 36	47670-10	Hoop Set - Decking Beam 58
		47772-12	Series E Track Fitting w/ Round Ring - 1,000 lbs. WLL 62, 97

INDEX BY PRODUCT NUMBER

47800-10	Overcenter Buckle - 1 3/4" - 1,666 lbs. WLL 90	48496-11	Lashing Winch - 2,500 lbs. w/ Double Hex Drive 8, 78
47934-11	Wheel Dolly Strap 2" x 86" 77	48672-13	Series E Ratchet Strap - 1-pc. End - 12' 68
47935-11	Wheel Dolly Strap w/ S Hooks 77	48672-14	Series E Ratchet Strap - 1-pc. End - 16' 68
47935-12	Wheel Dolly Strap w/ Spring E Fittings 77	48672-15	Series E Ratchet Strap - 1-pc. End - 20' 68
47944-10	Round Ring - 2" - 900 lbs. WLL 94	48672-16	LAD Ratchet Strap w/ Double Stud Fitting 12' 50
47970-10	2" x 27' Ratchet Strap w/ 40891-18 Flat Hooks . . . 36	48672-17	LAD Ratchet Strap w/ Double Stud Fitting 16' 50
47970-11	2" x 30' Ratchet Strap w/ 40891-18 Flat Hooks . . . 36	48672-18	LAD Ratchet Strap w/ Double Stud Fitting 20' 50
47971-10	2" x 27' Ratchet Strap w/ 40891-18 Flat Hooks . . . 36	48672-22	Plate Trailer Ratchet Strap Assy w/ Wire Hooks 12' 68
47971-11	2" x 30' Ratchet Strap w/ 40891-18 Flat Hooks . . . 36	48672-23	Plate Trailer Ratchet Strap Assy w/ Wire Hooks 16' 68
48101-103	Web Winch - 3-Bar - Weld-on 6	48672-24	Plate Trailer Ratchet Strap Assy w/ Wire Hooks 20' 68
48101-103-XZ	Web Winch - 3-Bar - Low Profile X-Treme Zinc Finish. . . 6	48672-33	Series E TLR Ratchet Strap - 1-pc. End - 12' 65
48101-133	Web Winch - 3-Bar - Low Profile Weld-on 6	48672-34	Series E TLR Ratchet Strap - 1-pc. End - 16' 65
48101-143	Web Winch - 3-Bar - Standard 6	48672-35	Series E TLR Ratchet Strap - 1-pc. End - 20' 65
48101-163-XZ	Web Winch - 3-Bar - Standard X-Treme Zinc Finish . . 6	48770-10	Ratchet Buckle - 1" - 500 lbs. WLL 88
48101-173	Web Winch - 3-Bar - Standard C Track Slider. 6	48783-10	Web Winch - Bottom Mount - Double Cap 2
48117-21-120.00	Series E Horizontal Track - 10' (Galvanized) 55	48904-10	Bolt Plate, 2", 30 degree, Clear Zinc Plated 95
48117-21-60.00	Series E Horizontal Track - 5' (Galvanized) 55	48922-10	2 x 18" Fixed End Strap w/ 40891-18 Flat Hook & Loop 40
48117-25-120.00	Series E Horizontal Track - 10' (Gray) 55	48922-11	3 x 18" Fixed End Strap w/ 41766-18 Flat Hook & Loop 40
48117-25-60.00	Series E Horizontal Track - 5' (Gray) 55	48922-12	4 x 18" Strap w/ 41766-18 Flat Hook & Loop 40
48117-32-120.00	Series E Horizontal Track - 10' Black Powdercoat 55	48922-13	2 x 18" Fixed End Strap w/ 43120-13 Wire Hook & Loop 39
48253-13	Plate Trailer Ratchet Strap w/ Wire Hook and E Fitting 12' 68	48922-15	4 x 18" Strap w/ 43120-20 Narrow Hook & Loop 40
48253-14	Plate Trailer Ratchet Strap w/ Wire Hook and E Fitting 16' 68	48922-16	2" Fixed End Strap w/ 43366-21 Chain Anchor & Loop 39
48253-15	Plate Trailer Ratchet Strap w/ Wire Hook and E Fitting 20' 68	48922-17	3 x 33" Strap w/ 43366-12 Chain Anchor & Loop 40
48253-16	Plate Trailer Ratchet Strap w/ F Fitting and E Fitting 12' 68	48922-18	4 x 33" Strap w/ 43366-14 Chain Anchor & Loop 40
48253-17	Plate Trailer Ratchet Strap w/ F Fitting and E Fitting 16' 68	48922-20	3 x 18" Strap w/ 43365-12 Grab Hook & Loop 40
48253-18	Plate Trailer Ratchet Strap w/ F Fitting and E Fitting 20' 68	48965-10	Ratchet Buckle - 3" - 7,333 lbs. WLL. 90
48253-19	Plate Trailer Cam Strap w/ Wire Hook and E Fitting 12' 67	48968-11	Roll-Off Container Hook - 5,400 lbs. WLL 93
48253-20	Plate Trailer Cam Strap w/ Wire Hook and E Fitting 16' 67	48987-20	3" x 27' Ratchet Strap w/ 41766-18 Flat Hooks - 5,400 lbs. WLL 37
48253-21	Plate Trailer Cam Strap w/ Wire Hook and E Fitting 20' 67	48987-21	3" x 30' Ratchet Strap w/ 41766-18 Flat Hooks - 5,400 lbs. WLL 37
48253-22	Plate Trailer Cam Strap w/ F Fitting and E Fitting 12' 67	48987-24	3" x 27' Ratchet Strap w/ 43366-12 Chain Anchors - 5,400 lbs. WLL. 37
48253-23	Plate Trailer Cam Strap w/ F Fitting and E Fitting 16' 67	48987-25	3" x 30' Ratchet Strap w/ 43366-12 Chain Anchors - 5,400 lbs. WLL. 37
48253-24	Plate Trailer Cam Strap w/ F Fitting and E Fitting 20' 67		
48407-10	Economy Cargo Sta 87" - 102" - Square Feet 60		
48485-11	Single Replacement Cleat. 76		
48487-24	2" x 140" Auto Hauler Winch Strap 76		

INDEX BY PRODUCT NUMBER

48987-28	3" x 27' Ratchet Strap w/ 43120-20 Wire Hooks - 5,400 lbs. WLL	37	49207-137-RW	Winch Double L Slider Standard	4
48987-29	3" x 30' Ratchet Strap w/ 43120-20 Wire Hooks - 5,400 lbs. WLL	37	49207-137-XZ	Winch Double L Slider Standard - w/ 7mm Frame X-Treme Zinc Plated	4
48987-90-27	3" x 27' ANCRA X-TREME Ratchet Strap w/ 41766-18 Flat Hooks	34	49207-187	Winch Double L Slider Low Profile w/ 7mm Frame	5
48987-90-30	3" x 30' ANCRA X-TREME Ratchet Strap w/ 41766-18 Flat Hooks	34	49207-187-RW	Winch Double L Slider Low Profile w/ 7mm Frame X-Treme Zinc Plated	5
48987-92-27	3" x 27' ANCRA X-TREME Ratchet Strap w/ 43366-14 Chain Anchors	34	49207-187-XZ	Winch Double L Slider Low Profile w/ 7mm Frame X-Treme Zinc Plated	5
48987-92-30	3" x 30' ANCRA X-TREME Ratchet Strap w/ 43366-14 Chain Anchors	34	49207-273	3-Bar Standard Double L Slider Winch	6
49015-18	18" Door Pull Strap	62	49207-273-XZ	3-Bar Standard Double L Slider Winch X-Treme Zinc Finish	6
49015-24	24" Door Pull Strap	62	49207-283-XZ	3-Bar Low Profile Double L Slider Winch X-Treme Zinc Finish	6
49015-36	36" Door Pull Strap	62	49211-10	Rubber Rope Hooks - 100-pc. Bag	19
49020-20	6' Auto Tie Down Strap w/ Snap Hooks	76	49242-10-120	Winch Track - 10' Aluminum Double L	11
49020-21	8' Auto Tie Down Strap w/ Snap Hooks	76	49246-10-BP	Winch Std Utility Trailer Track Slider w/ Clip	5
49020-22	12' Auto Tie Down Strap w/ Snap Hooks	76	49288-10	TrackStar - Accessory Mounting Kit (8" Track & Hardware)	85
49021-20	Series E HD Ratchet Buckle Strap - 12'	68	49313-13	Series L Track (Galvanized) 10', 1" Notched Holes	56
49021-21	Series E HD Ratchet Buckle Strap - 16'	68	49344-10	Coil Rack - Light Duty	16
49021-22	Series E HD Ratchet Buckle Strap - 20'	68	49344-12	Coil Rack - Heavy-Duty	16
49021-30	Series E HD TLR Ratchet Buckle Strap - 12'	65	49345-10	Floor Chain Tie Down - Welded	27
49021-31	Series E HD TLR Ratchet Buckle Strap - 16'	65	49346-10	4" x 27' Ratchet Strap w/ 41766-18 Flat Hooks - 5,400 lbs. WLL	37
49021-32	Series E HD TLR Ratchet Buckle Strap - 20'	65	49346-11	4" x 30' Ratchet Strap w/ 41766-18 Flat Hooks - 5,400 lbs. WLL	37
49023-20	Auto Tie Down - Series E w/ RTJ Hooks - 6'	77	49346-12	4" x 27' Ratchet Strap w/ Narrow Wire Hooks - 6,600 lbs. WLL	37
49023-21	Auto Tie Down - Series E w/ RTJ Hooks - 8'	77	49346-13	4" x 30' Ratchet Strap w/ Narrow Wire Hooks - 6,600 lbs. WLL	37
49023-22	Auto Tie Down - Series E w/ RTJ Hooks - 12'	77	49346-14	4" x 27' Ratchet Strap w/ 43366-14 Chain Anchor - 5,400 lbs. WLL	37
49025-20	Electronic Strap 12'	67	49346-15	4" x 30' Ratchet Strap w/ 43366-14 Chain Anchor - 5,400 lbs. WLL	37
49025-21	Electronic Strap 16'	67	49346-90-27	4" x 27' Ratchet Strap w/ 41766-18 Flat Hooks	35
49025-22	Electronic Strap 20'	67	49346-90-30	4" x 30' Ratchet Strap w/ 41766-18 Flat Hooks	35
49039-50	HD Series E Beam Assy - 96"	58	49346-91-27	4" x 27' Ratchet Strap w/ 43366-14 Chain Anchors	35
49039-51	HD Series E Beam Assy - 102"	58	49346-91-30	4" x 30' Ratchet Strap w/ 43366-14 Chain Anchors	35
49039-52	HD Series E Beam Assy - 106"	58	49346-93-27	4" x 27' Ratchet Strap w/ 43120-13 Wire Hooks	35
49205-25	Heavy-Duty Jack Bar One-Piece - Galvanized - Bolt-on Feet - 85" - 104"	61	49346-93-30	4" x 30' Ratchet Strap w/ 43120-13 Wire Hooks	35
49205-26	Heavy-Duty Jack Bar One-Piece - Galvanized - Bolt-on Feet - 85" - 114"	61	49347-10	2" x 18" Fixed End Strap w/ 40891-18 Flat Hook & Ratchet	39
49205-27	Heavy-Duty Jack Bar One-Piece Galvanized w/ Hoop Bolt-on Feet 85" - 114"	61			
49205-28	Heavy-Duty Jack Bar One-Piece Galvanized w/ Hoop Bolt-on Feet 86" - 104"	61			
49205-31	Universal Jack Bar 51" to 114"	61			
49207-127	Winch Double L Slider Storable - w/ 7mm Frame	4			
49207-127-RW	Winch Double L Slider Storable Web	4			
49207-127-XZ	Winch Double L Slider Storable - w/ 7mm Frame X-Treme Zinc Plated	4			
49207-137	Winch Double L Slider Standard - w/ 7mm Frame	4			

INDEX BY PRODUCT NUMBER

49347-11	2" x 25' Strap w/ 40891-10 Flat Hook	39	49368-12	Strap Assy - 2 Cam, 2 Ratchet w/ Vinyl S Hooks, 4-pack	84
49347-12	2" x 28' Strap w/ 40891-10 Flat Hook	39	49371-10	Stake Pocket Anchor	63
49347-13	3" x 18" Strap w/ 41766-18 Flat Hook & Ratchet	40	49377-10	Corner Protector - Steel for Chain	17
49347-14	3" x 25' Strap w/ 41766-18 Flat Hook - 15,000 lbs.	40	49377-11	Rubber Coated Steel Corner Protector	17
49347-15	3" x 28' Strap w/ 41766-18 Flat Hook - 15,000 lbs.	40	49382-10	Transmat 30" x 42" Section	63
49347-16	4" x 18" Strap w/ 41766-18 Flat Hook & Ratchet	40	49400-10	Jack Bar Component Kit - Red Handle	60
49347-17	4" x 25' Strap w/ 41766-18 Flat Hook - 15,000 lbs.	40	49400-11	Jack Bar Component Kit - Black Handle	60
49347-18	4" x 28' Strap w/ 41766-18 Flat Hook - 15,000 lbs.	40	49410-13	Ratchet Buckle - 2" - 3,666 lbs. WLL - TLR	89
49347-19	2" x 18" Fixed End Strap w/ 43120-13 Wire Hook & Buckle	39	49414-15	LAD Beam Standard - 95.1" - 105.6"	46
49347-20	2" x 25' Adjustable End w/ 43120-13 Wire Hook	39	49414-15-RT	Replacement Tube for 49414-15 Standard LAD Beam	47
49347-21	2" x 28' Adjustable End w/ 43120-13 Wire Hook	39	49414-19	LAD Beam Heavy-Duty - 95.2 - 105.6	46
49347-25	4" x 18" Strap w/ 43120-20 Narrow Hook & Buckle	40	49414-19-RT	Replacement Tube for 49414-19 Heavy-Duty LAD Beam	47
49347-26	4" x 25' Strap w/ 43120-20 Narrow Hook	40	49414-21	Aftermarket Beam Standard - 97.3" - 108.8"	48
49347-27	4" x 28' Strap w/ 43120-20 Narrow Hook	40	49414-21-RT	Replacement Tube for 49414-21	48
49347-28	2" x 33" Fixed End Strap w/ 43366-21 Chain Anchor & Ratchet	39	49439-10	Shoring Bar, F Series - Round	59
49347-29	2" x 25' Strap w/ 43366-21 Chain Anchor	39	49439-11	Shoring Bar, F Series - Round (1" Hole Track)	59
49347-30	2" x 28' Strap w/ 43366-21 Chain Anchor	39	49439-20	Shoring Bar, F Series - Square	59
49347-31	3" x 33" Strap w/ 43366-12 Chain Anchor & Buckle	40	49439-21	Shoring Bar, F Series - Square (1" Hole Track)	59
49347-32	3" x 25' Strap w/ 43366-12 Chain Anchor	40	49443-10	Housing Assembly (w/ Trigger, Set Screw, Rack & Lever)	60
49347-33	3" x 28' Strap w/ 43366-12 Chain Anchor	40	49445-12	Beam Release Bar	47
49347-34	4" x 33" Strap w/ 43366-14 Chain Anchor & Buckle	40	49446-10	Lift-A-Deck Kit with Beam Release Bar	47
49347-35	4" x 25' Strap w/ 43366-14 Chain Anchor	40	49454-11	Rubber Rope - 3/8" Solid Core - 150' Roll	20
49347-36	4" x 28' Strap w/ 43366-14 Chain Anchor	40	49454-13	Rubber Rope - 7/16" Solid Core - 150' Roll	20
49347-40	3" x 18" Strap w/ 43365-12 Grab Hook & Buckle	40	49526-10	4" x 5' Strap w/ Hook for Roll-Off Containers	33
49347-41	3" x 25' Strap w/ 43365-12 Grab Hook	40	49526-11	4" x 5' Strap w/ Sewn Loop End for Roll-Off Containers	33
49347-42	3" x 28' Strap w/ 43365-12 Grab Hook	40	49526-90	4" x 5' ANCRA X-TREME Strap w/ Hook for Roll-Off Containers	33
49348-11	Bar Keep Cargo Bar Holder	62	49526-91	4" x 5' ANCRA X-TREME Strap w/ Sewn Loop for Roll-Off Containers	33
49349-10	Ratchet Buckle - 4" - 8,000 lbs. WLL	90	49527-10	GlideLock Slider Bracket - For Double L Track	16
49359-10	Series A Horizontal Track Aluminum	56	49542-10	E Fitting w/ D-Ring	62, 97
49360-13	Decking/Shoring Beam Steel Series E - 92.1" - 102.9" Long	58	49562-17-72.00	LAD Narrow Single Track	49
49368-10	Strap Assy - 1" - Ratchet Buckle - 15' w/ Vinyl S Hooks, 4-pack	84	49577-10	Chain Corner Protector	17
49368-11	Strap Assy - 1" - Cam Buckle - 6' w/ Vinyl S Hooks, 4-pack	84	49583-10	Floor Chain Tie Down - Bolt-on	27
			49584-10	Plastic Corner Protector	17
			49603-10	TrackStar Wheelchock	85
			49706-10	Winch Standard Wilson Track Slider w/ Clip	5
			49706-11	Winch Low Profile Wilson Track Slider w/ Clip	5
			49715-10	Ratchet Buckle - 2" - 1,500 lbs. WLL - TLR	89
			49716-10	Porta Winch	9
			49716-10-RW	Ratcheting Porta Winch	9
			49716-11	Porta Winch Offset	9
			49717-10	Porta Anchor	9

INDEX BY PRODUCT NUMBER

49723-10	Silvercap Overdrive Ratcheting Cap	12	49917-10	Bolt Plate, 1" 45 degree.	95
49756-10	Steel Corner Protector	17	49917-11	Bolt Plate, 1" Flat	95
49768-10	Sliding Double L Hook	15	49968-10	Bolt Plate, 2" 45 degree.	95
49770-10	Waste Container J Hook - 5,100 lbs. WLL	93	49988-10	Pallet Deck	53
49789-10-120.00	Winch Track - 10' Aluminum Double L Low Profile	11	49997-113	Web Winch - Side Mount - 3-Bar.	6
49811-20L	Low Profile Foot and Channel Assembly	46	50013-31	Screw Pin Anchor Shackle - Galvanized, 5/16", 1,500 lbs. WLL	24, 99
49828-10-30	1/4" x 30' Cable Assembly w/ Chain Anchor.	41	50013-38	Screw Pin Anchor Shackle - Galvanized, 3/8", 2,000 lbs. WLL	24, 99
49828-10-32	1/4" x 32' Cable Assembly w/ Chain Anchor.	41	50013-44	Screw Pin Anchor Shackle - Galvanized, 7/16", 3,000 lbs. WLL	24, 99
49828-11-30	5/16" x 30' Cable Assembly w/ Chain Anchor.	41	50013-50	Screw Pin Anchor Shackle - Galvanized, 1/2", 4,000 lbs. WLL	24, 99
49828-11-32	5/16" x 32' Cable Assembly w/ Chain Anchor.	41	50013-63	Screw Pin Anchor Shackle - Galvanized, 5/8", 6,500 lbs. WLL	24, 99
49828-12-30	7/32" x 30' Cable Assembly w/ Chain Anchor.	41	50013-75	Screw Pin Anchor Shackle - Galvanized, 3/4", 9,500 lbs. WLL	24, 99
49828-12-32	7/32" x 32' Cable Assembly w/ Chain Anchor.	41	50013-88	Screw Pin Anchor Shackle - Galvanized, 7/8", 13,000 lbs. WLL	24, 99
49834-10	3 Bar Adjuster - 2" - 1,000 lbs. WLL.	91	50013-100	Screw Pin Anchor Shackle - Galvanized, 1", 17,000 lbs. WLL	24, 99
49880-12	12 Ton Bottle Jack w/ 2-Pc. Handle	103	50014-50	Clevis Pin Anchor Shackle - Galvanized, 1/2", 4,000 lbs. WLL	24, 99
49880-20	20 Ton bottle Jack w/ 2-Pc. Handle	103	50014-63	Clevis Pin Anchor Shackle - Galvanized, 5/8", 6,500 lbs. WLL	24, 99
49893-10	18" x 18" Safety Flag & Wooden Dowel	72	50015-10	ERGO 360 Winch Bar - Standard	13
49893-11	18" x 18" Cotton Flag w/ Steel Rod	72	50015-20	ERGO 360 Winch Bar - Combination.	13
49893-12	18" x 18" Red Flag w/ Grommets	72	50015-21	ERGO 360 Winch Bar - Combination Box End.	13
49893-13	18" x 18" PVC Coated Orange Flag & Wooden Dowel	72	50016-25	Quick Links - Zinc Plated, 1/4", 880 lbs. WLL	24, 99
49893-14	18" x 18" PVC Coated Orange Flag w/ Grommets	72	50016-31	Quick Links - Zinc Plated, 5/16", 1,760 lbs. WLL	24, 99
49893-18	18" x 18" Fluorescent Orange Mesh Flag w/ Wire Hooks	72	50016-38	Quick Links - Zinc Plated, 3/8", 2,200 lbs. WLL	24, 99
49894-10	18" x 84" Wide Oversized Load Banner w/ 4 Ropes	73	50017-10	Twin Clevis G70 - Zinc Plated, 5/16", 4,700 lbs. WLL	25, 100
49894-11	18" x 84" Wide Oversized Load Banner w/ 2 Ropes	73	50017-11	Twin Clevis G70 - Zinc Plated, 3/8", 6,600 lbs. WLL	25, 100
49894-12	14" x 72" Wide Oversized Load Banner w/ 4 Ropes	73	50017-12	Twin Clevis G70 - Zinc Plated, 7/16", 11,300 lbs. WLL	25, 100
49894-13	18" x 84" Oversized Load Mesh Banner	73	50019-10	Slip Hooks G70 - Zinc Plated - No Latch, 1/4", 3,150 lbs. WLL	25, 100
49894-14	18" x 84" Wide Load Mesh Banner.	73	50019-11	Slip Hooks G70 - Zinc Plated - No Latch, 5/16", 4,700 lbs. WLL	25, 100
49895-10	12" x 96" Canadian D Sign w/ 8 Grommets	73	50019-12	Slip Hooks G70 - Zinc Plated - No Latch, 3/8", 6,600 lbs. WLL	25, 100
49895-11	12" x 96" Reflective Canadian D Sign w/ 10 Grommets	73	50019-13	Slip Hooks G70 - Zinc Plated - No Latch, 1/2", 11,300 lbs. WLL	25, 100
49895-12	18" x 96" Reflective Canadian D Sign w/ 10 Grommets	73			
49895-13	18" x 96" Reflective Canadian D Sign w/ 10 Grommets, reverse side: Oversize Load	73			
49896-10	1/2" Forged Ring Assy w/ Bolt-on Clip	14			
49896-11	1/2" Forged Ring Assy w/ Weld-on Clip	14			
49897-10	5/8" Forged Ring Assy w/ Weld-on Clip	14			
49898-10	3/4" Forged Ring Assy w/ Weld-on Clip	14			
49899-10	1" Forged Ring Assy w/ Weld-on Clip	14			
49913-10	Tarp Protector	17			
49914-10	Swivel J Idler Fitting - 3,333 lbs. WLL	97			
49914-11	Swivel J Idler Fitting Low Profile - 3,333 lbs. WLL	97			

INDEX BY PRODUCT NUMBER

50019-20	Slip Hooks G70 - Zinc Plated - w/ Safety Latch, 1/4", 3,150 lbs. WLL	25, 100	50191-10	Heavy-Duty Aftermarket Beam - 97.3" - 108.8"	43
50019-21	Slip Hooks G70 - Zinc Plated - w/ Safety Latch, 5/16", 4,700 lbs. WLL	25, 100	50191-10-RT	Replacement Tube for 50191-10	43
50019-22	Slip Hooks G70 - Zinc Plated - w/ Safety Latch, 3/8", 6,600 lbs. WLL	25, 100	50192-14-72.00	LAD Standard Single Track	44
50019-23	Slip Hooks G70 - Zinc Plated - w/ Safety Latch, 1/2", 11,300 lbs. WLL	25, 100	50193-30-72.00	Heavy-Duty Beveled Aircraft Style Track 72"	102
50024-10	Tarp Hook	15	50194-100	Low Profile Allen Sleeve Nut and Bolt Kit for Beams	48, 59
50037-10	Ratchet Buckle - 2" - 3,666 lbs. WLL - Web Keeper LWH	89	50199-10	Cargo Net for Short Bed Pickups	86
50055-10	Beam Release Bar Holder	47	50199-11	Cargo Net for Long Bed Pickups	86
50058-18-72.00	LAD Flanged Single Track	49	50312-10	Wide Top LAD Beam w/ Reinforced 1-in. Sides	46
50072-14-72.00	LAD Flanged Double Track	50	50312-10-RT	Replacement Tube for 50321-10	46
50080-11	Wide Top LAD Beam Assembly - 95.1" - 105.6"	46	50354-10	5th Wheel Release Hook	42
50080-11-RT	Replacement Tube for 50080-11	46	50360-20	XHD™ Chain Binder 5/16"	27
50089-12	X-TREME Corner Guards - 12" x 8" x 8" - Made In The USA	18	50360-21	XHD™ Chain Binder 3/8"	27
50089-24	X-TREME Corner Guards - 24" x 8" x 8" - Made In The USA	18	50364-38-10	G70 - XHD™ 3/8" Chain Assembly, 10-ft	22
50089-36	X-TREME Corner Guards - 36" x 8" x 8" - Made In The USA	18	50364-38-20	G70 - XHD™ 3/8" Chain Assembly, 20-ft	22
50089-48	X-TREME Corner Guards - 48" x 8" x 8"- Made In The USA	18	50391-10	Premium Cargo Strap Winder	15
50092-10	EZ Winder Web Winder	15	50398-20	Cargo Control Display - Freestanding.	103
500-C8-RD	2" x 8' Red Ratchet Strap w/ Twisted Snap Hook	77	50404-10-33	X-TREME Rope Tie Down, 33-ft	41
50105-11	Poly Deckboard for LAD System for 24" Beam Center.	51	50404-10-36	X-TREME Rope Tie Down, 36-ft	41
50115-10	Series E Track Fitting - Heavy-Duty w/ Round Ring 2,000 lbs. WLL	66, 96	50404-10-40	X-TREME Rope Tie Down, 40-ft	41
50115-11	Series E Track Fitting - Heavy-Duty w/ D-Ring 2,000 lbs. WLL	66, 96	50409-10	Toss 'N Tie.	41
50117-10	Lever Binder Locking Clip	27	50409-10-4PK	Toss 'N Tie 4-pack	41
50140-10	EZ Binder Lever Load Binder	26	50409-10- BULK	Toss 'N Tie bulk.	41
50149-10-310RS	Captive Tether Fitting for 310R Track	57	50410-12	Beam Rack	62
50158-10	Series E Wide Top Decking Beam - 92.9" - 103.8"	58	50412-100	Zinc Plated Clevis Pin Kit.	23
50179-10	2" x 102" Auto Hauler Ratchet Strap w/ Wire Hooks	76	50412-102	Zinc Plated Clevis Pin Kit.	23
50179-11	2" x 102" Auto Hauler Ratchet Strap w/ Low Profile Swivel J Hooks.	76	50412-103	Zinc Plated Clevis Pin Kit.	23
50186-10	Wide Top Aftermarket Beam - 97.2" - 108.8"	43	50420-10	Vers-A-Deck	44
50186-10-RT	Replacement Tube for 50186-10	43	50430-10	Magnetic Flag Holder	72
50187-30	Low Profile Foot and Channel Assembly	42	50432-10	Fluorescent Mesh Safety Vest, Lime Green	74
50187-31	Lift-A-Deck II Foot Assembly.	42	50432-11	Fluorescent Mesh Safety Vest, Orange	74
50188-10	Foot and Channel Assy for Aftermarket Beams	43	50434-10	Triangle Warning Kit	74
			50433-10	HD Strap Storage Band	15
			50435-L	Work Gloves	74
			50435-XL	Work Gloves.	74
			50435-3T-L	Insulated Work Gloves	74
			50435-3T-XL	Insulated Work Gloves	74
			50437-10PK	LED Flashlight	74
			50440-10	HELP Light Kit.	74
			50451-11	Corner Protector Placement Tool	19
			50456-2-GALV	Trailer Access Steps, 2-steps	64
			50456-3-GALV	Trailer Access Steps, 3-steps	64
			50456-KIT	Trailer Access Steps Installation	64
			50480-100	Knock Down Pallet Deck	53
			50486-10	Rubber Beam Stop	47
			50490-10	Flatbed Trailer Ladder	19

INDEX BY PRODUCT NUMBER

50491-10	Freight Hauler Bracket Kit	19	95004	1" x 8' Cam Straps w/ Vinyl-Coated	
50514-10	Security Divider & Deckboard, single panel.	52		S Hooks, 4-pack	85
50515-10	Security Divider & Deckboard, Bulkhead Kit, HD Lockable Beams, 2 panels.	52	95005	1" x 10' Ratchet Straps w/ Vinyl-Coated	
50515-11	Security Divider & Deckboard, Bulkhead Kit, STD Lockable Beams, 2 panels	52		S Hooks, 4-pack	85
50530-10	FasTrack Lift-A-Deck II Conversion Track	49	95006	Two 1" Cam Straps & Two 1" Ratchet Straps w/ Vinyl-Coated S Hooks, 4-pack	85
50532-12	Commercial Reflective Tape Safety Vest, Lime Green	73	95007	1" x 12' Endless Ratchet Straps, 2-pack	85
50557-10	Storage Bracket Kit for Flatbed Trailer Ladder	19	LR0401-01	Fork Lift Stand	103
50532-13	Commercial Reflective Tape Safety Vest, Orange	73			
52210GL	Goldline EPDM Tarp Ties, 10"-50 per Box	20			
52210SE	Silverline Elite EPDM Tarp Ties, 10"-50 per Box	20			
52210C	Natural Rubber Tarp Ties, 10"-50 per Box	20			
52215GL	Goldline EPDM Tarp Ties, 15"-50 per Box	20			
52215SE	Silverline Elite EPDM Tarp Ties, 15"-50 per Box	20			
52215C	Natural Rubber Tarp Ties, 15"-50 per Box	20			
52221GL	Goldline EPDM Tarp Ties, 21"-50 per Box	20			
52221SE	Silverline Elite EPDM Tarp Ties, 21"-50 per Box	20			
52221C	Natural Rubber Tarp Ties, 21"-50 per Box	20			
52231GL	Goldline EPDM Tarp Ties, 31"-50 per Box	20			
52231SE	Silverline Elite EPDM Tarp Ties, 31"-50 per Box	20			
52231C	Natural Rubber Tarp Ties, 31"-50 per Box	20			
52241GL	Goldline EPDM Tarp Ties, 41"-50 per Box	20			
52241SE	Silverline Elite G4EPDM Tarp Ties, 41"-50 per Box	20			
52241C	Natural Rubber Tarp Ties, 41"-50 per Box	20			
95001	1" x 8' Cam Straps w/ Vinyl-Coated S Hooks, 2-pack	84			
95002	1" x 10' Ratchet Straps Vinyl-Coated S Hooks, 2-pack	85			
95003	1" x 6' Retractable Ratchet Straps w/ Vinyl Coated S Hooks, 2-pack	85			

INDEX BY PRODUCT NAME

Adjuster, 3-Bar Slide	91	Cleat, Single	76	Hook, Tarp	15
Allen Sleeve Nut & Bolt Kit, Low Profile	48, 59	Clevis Hooks	23, 98	Hooks, Flat	93
Anchor, Chain	97	Clevis, Twin	25, 100	Hooks, Slip	25, 94, 100
Auto Tie Downs	76, 77, 78	Coil Racks	16	Hooks, Snap	94
Banners, Safety	73	Corner Protectors	17, 18	Hooks, Waste	93
Bar, Beam Release	47	Corner Protector Placement Tool	19	Hooks, Wire	92
Bars, Cargo Sta	60	Deckboard, Security Divider	52	Hoop Set, Cargo Sta	60
Bars, Jack	61	Deckboard, Security Divider Kit	52	Hoops, Decking Beam	58
Bars, Shoring	59	Decking Beam Hoops	58	Jack Bar Component Kits	60
Bars, Winch	12	Decking/Shoring Beams	46, 48, 58, 59	Jack Bars	61
Beam, Foot & Channel Assembly	46, 47, 59	Display, Cargo Control	103	Jacks, Bottle	103
Beam Release Bar	47	Dolly Straps	77	Ladder, Flatbed Trailer	19
Beam Release Bar Holder	47	Door Pull Straps	62	Load Binder	26, 27
Beam Replacement Tube	47	D-Rings, Forged	14	Lift-A-Deck II	45, 46, 48, 49, 50
Beam Sockets	59	Electronic Restraint Straps	67	Lift-A-Deck II Straps	50
Beam Stop, Rubber	46	ERGO 360 Winch Bars	13	Lift-A-Deck Foot Assembly	47
Beams, Decking/Shoring	46, 48, 58, 59	EZ Binder	26	Lift-A-Deck Poly Deckboard	51
Binders, Chain Load	26, 27	EZ Winder	15	Lifting Slings	78, 79, 80
Binder, Ratchet	27	F Series - Shoring Bar	55	Links, Quick	24, 99
Binder, Recoilless	26	Fastrack LAD II Conversion Track	50	Locking Clip, Lever Binder	27
Bolt Plates	95	Fittings, Pan	63	Logist-A-Panel	51
Bottle Jacks	103	Fittings, Track	61, 96, 975, 102	Merchandising Aids	103
Buckle, Roller	91	Flag, Safety	72	Mini Ratchet Strap	84
Buckles, Cam	91	Flashlight	74	Nets, Cargo	86
Buckles, Overcenter	90	Flat Hooks	93	Nets, Custom	69
Buckles, Ratchet	88, 89, 90	Flat Latch Repair Kit	59	Overcenter Buckles	90
Cable Assemblies	41	Floor Chain Tie Down	27	Pallet Deck	53
Cam Buckle Strap Assemblies	50, 66, 67, 84, 85	Foot & Channel Assembly, Low Profile	46	Pan Fittings	63
Cam Buckles	91	Fork Lift Stand	103	Poly Deckboard, LAD	51, 52
Cargo Bar Holder	62	Friction Mat	61	Poly Deckboard Calculator	70
Cargo Nets	69, 86	Gear Drive Tensioner	40	Plate Trailer Straps	67, 68
Cargo Sta	60	GlideLock	16	Plates, Bolt	95
Cargo Sta Replacements	58	Gloves, Reflective Work	74	PortaAnchor	9
Cargo Sta, Hoop Set	60	Goldline EPDM Tarp Ties	20	PortaWinch	9
Chain	21, 22	Grab Hook Assembly	98	Protectors, Corner	17, 18
Chain Anchor	97	HD Strap Storage Band	20	Protector, Tarp	17
Chain Assemblies	21, 22	Holder, Cargo Bar	54	Protectors, Web	17
Chain Attachments	24, 25, 95, 97, 98, 99, 100	Hook, Clevis	23, 98	Ratchet Buckle Strap Replacements	39, 40
Chain Binder, Lever	26	Hook, Container	91	Ratchet Buckle Strap, Series E	65, 66
Chain Binder, Ratchet	27	Hook, Corner Iron	15	Ratchet Strap Assemblies	34-40, 50, 65, 66, 84
Chain Binder, Recoilless	26	Hook, Double L Track Slider	15	Ratchet Strap Assy, Web Keeper	38
Chain Binder, Safety Clip	27	Hook, Grab	98	Ratchet Strap, Mini	84
Chain Binder, XHD	27	Hook, H-2	15	Ratchet Buckles	88, 89, 90
Chain Hardware	24, 25, 99, 100	Hook, Rave	92	Ratcheting Cap, OverDrive	12
Channel Assembly, Replacement	47, 48, 59	Hook, RTJ Cluster	98	Reflectors, Lights	73
		Hook, Rubber Rope	20	Release Hook, 5th Wheel	42
		Hook, S	92		
		Hook, Swivel J	97		

INDEX BY PRODUCT NAME

Retract-A-Roll	54	Straps, Dolly	77	Winch Track	11
Rings	94	Straps, Driver Assist	63	Winches Web	2, 3, 4, 5, 6
Rings, Delta	94	Straps, Door Pull	62	Winch, Cable	7
Roll-On/Roll-Off Container Straps	33	Straps, Electronic	67	Winches, Combination	7
Roller Buckle	91	Straps, Plate Trailer	67, 68	Winches, Lashing	8, 78
Rope Tie Down, X-TREME	41	Straps, Ratchet		Winches, PortaWinch, PortaAnchor	9
Rope Tie Offs	62	Buckle	34-40, 49, 65, 68, 74, 75, 84	Winches, Sliders	3, 4, 5
Rope, Rubber	20	Straps, Series F	66	Winder, Web	15
RTJ Cluster Hook	96	Straps, Tension Limiting Ratchet	65	Winder Strap	15
Rubber Rope	20	Straps, Transit w/ RTJ Hooks	77	Wire Hooks	92
Rubber Rope Hook	20	Straps, Utility	84	Winches, 3-Bar	6
Safety Vests	74	Straps, Winch	28, 29, 30, 31, 32, 33, 76	X-TREME Guard Corner Protector	18
Series A Track	56	Tarp Protector	17	X-TREME Rope Tie Down	41
Series E Heavy-Duty Strap	56, 66	Tarp Ties	20	X-TREME Winch Strap, Assemblies	28, 29, 30, 33, 34, 35, 38, 39
Series E Ratchet Buckle Strap	65, 68	Tension Limiting Ratchet Assemblies	65		
Series E Track	55	Tether Track	57		
Series E Transit Strap	77	Tie Downs, Auto	74, 75		
Series F Channel Track	57	Tie Downs, Cam Buckle Packaged	84, 85		
Series F Track	56	Tie Downs, Combo Packs	84, 85		
Shackles	24, 99	Tie Downs, Floor Chain	27		
Shoring Bar - F Series	59	Tie Downs, Ratcheting Packaged	84, 85		
Signs, Safety	72	Tie Offs	62		
Silverline Elite EPDM Tarp Ties	20	Ties, Tarp	20		
Silverline Tarp Ties	20	Tire Bonnets	78		
Slings, Eye to Eye Web	81, 82	Toss 'N Tie	41		
Slings, Round	80	Track, Lift-A-Deck II	49, 50		
Slip Hooks	25, 98, 100	Track, Aircraft	102		
SilverCap OverDrive Ratcheting Cap	12	Track Fittings	61, 96, 97, 102		
Snap Hooks	94	Track, Heavy-Duty	102		
Socket, Beam	59	Track, Series A	56		
Stake Pocket Anchor	63	Track, Series E	55		
Steps, Trailer Access	64	Track, Series F	56		
Storage Bracket Kit for Flatbed		Track, Series F Channel	57		
Trailer Ladder	19	Trackstar Accessory Mounting Kit	85		
Strap, Ancra Lash	84	Trackstar WheelChock	85		
Strap, Ratchet		Transmat	63		
Assembly	34-40, 50, 66, 67, 84, 85	Triangle Warning Kit	74		
Strap, Cam Buckle		Truck & Trailer Fittings (pan, anchor)	63		
Assembly	50, 66, 67, 84, 85	Van Trailer Bracket Kit	19		
Strap, Lift-A-Deck II Assemblies	50	Vers-A-Deck	44		
Strap, Mini Ratchet	84	Vests, Safety	74		
Strap, Motorcycle	84	Utility Strap	84		
Strap, Series E	66	Web Protectors	17		
Strap, Series E Transit	77	Web Winder	15		
Strap, Storage Band	20	Webbing	101		
Strap, Trailer Door Limit	63	WheelChock	85		
Straps, Cam Buckle	49, 66, 67, 84	Winch Bars	14		
Straps, Container	33	Winch Straps	28, 29, 30, 31, 32, 33, 76		

CALIFORNIA PROPOSITION 65

What is Proposition 65 and how does it affect Ancra Cargo?

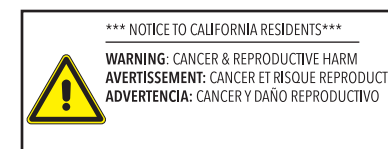

On August 31, 2018, the State of California enacted regulations that require products be marked at point of sale containing chemicals from a list of over 300 that can potentially cause cancer or reproductive harm. Ancra will comply with these regulations with the addition of Prop 65 labels to our products that contain any of these harmful substances.

Proposition 65 is a broad law that applies to any company operating in California, selling products in California, or manufacturing products that may be sold in, or brought into, California. Proposition 65 mandates that the Governor of California maintain and publish a list of chemicals that are known to cause cancer, birth defects and/or other reproductive harm. The list, which must be updated annually, includes a wide variety of chemicals that can be found in many everyday items, such as dyes, solvents, drugs, food-additives, by-products of certain processes, pesticides, and tobacco products.

The purpose of Proposition 65 is to ensure that people are informed about exposure to these chemicals. Proposition 65 also requires warnings to be placed on any product, product packaging, or literature accompanying a product that contains or may contain any of the more than 800 chemicals that the California Air Resources Board considers harmful. As noted above, many of the elements listed under Proposition 65 have been routinely used in everyday consumer items for years without documented harm.



ANCRA
CARGO[®]
CONSUMER/INDUSTRIAL



50 SINCE
1969
Leader in Load
Securement Innovation
 **ANCRA**
CARGO

CONSUMER/INDUSTRIAL DIVISION

Welcome current and future Ancra Customers!

With the printing of this catalog, Ancra celebrates its 50th year in business and the 10th anniversary of the Consumer/Industrial division. Two major milestones we are very proud of! We'd like to take this moment to extend our sincere appreciation to everyone who has helped make Ancra a success, especially those who have supported our expansion into the retail and commercial markets. We couldn't have done it without you!

As you browse through our catalog, you're sure to find products you recognize and hopefully a couple more that can help expand your business. New this year is our Bulk Bin Tie-Down program and Gin Wheel along with a few updates to our assortments and packaging. We also offer a solid line up of Cable Pullers, Fencing Installation Accessories, Vehicle Recovery Straps and Lifting Slings to complement our extensive Tie-Down selection. Whether it's a technical question, a price comparison, or a full line proposal, our experienced sales team is ready to assist. Just give us a call. We'll make it worth your time.

Thank you for your continued support of Ancra. We look forward to earning your business and another 50 great years!

Sincerely,
The Ancra Consumer/Industrial Team



CONTENTS

FENCING PRODUCTS	3-5
CABLE PULLERS	4
INSTALLATION ACCESSORIES	5
TIE-DOWNS	6-18
INDUSTRIAL	8-9
CONSUMER	10-12
COMMERCIAL	13
MOTORSPORTS	14-15
AUTOMOTIVE	16-17
EVENT TENT	18
HEAVY DUTY	19-26
WINCH STRAPS	20
WINCHES	21
WINCH BARS	21
CHAIN ASSEMBLIES (TRANSPORT)	22
CHAIN HARDWARE	23
CHAIN BINDERS	24
CARGO BARS	25
LOGISTIC STRAPS	25
HEAVY DUTY ACCESSORIES	26
BUNGEE CORDS & TARP TIES	27-30
SLINGS & RECOVERY STRAPS	31-34
SLINGS	32-33
VEHICLE RECOVERY STRAPS	34
CARGO CONTROL ACCESSORIES	35-38
TRUCK & TRAILER HARDWARE	36-37
NETS & BLANKETS	38
SAFETY PRODUCTS	39-41
SAFETY PRODUCTS	40
FLAGS & BANNERS	41
APPENDIX	42-45
GLOSSARY	42
PLANOGRAM SUPPORT	43
INDEX BY PART NUMBER	44-45

CONSUMER/INDUSTRIAL MISSION

Help our customers increase their share of the consumer and commercial cargo control markets and attract new customers through the supply of quality built, reliable and cost-effective products while maintaining the highest regard for meeting industry standards and cargo transportation safety requirements.

ABOUT ANCRA CARGO



Ancra Cargo is a full-line manufacturer of cargo control products and related accessories with an emphasis on commercial and heavy-duty fleet transport applications. The Ancra brand name is highly regarded by professionals throughout North America for quality and reliability. Our in-house engineering and experience help ensure that our products comply with current industry standards and federal transportation safety requirements. Ancra is a wholly owned business of The Heico Companies, LLC. Heico is a multi-billion-dollar, global entity, and through its holdings is the leading supplier of cargo control products in North America serving the Heavy Duty, Military, Aviation, Towing, Auto Transport, Power Sports, DIY Consumer, Commercial and Industrial markets.

FENCING PRODUCTS

CABLE PULLERS

Ankra cable pullers are available in different sizes with pulling capabilities ranging from 1,500 to 8,000 pounds. A variety of pullers are available to make pulls easier and more efficient. In addition to cable pullers, Ankra offers Wire Grips, Fence Pliers, Gin Wheel, and Wire Stretchers for your convenience.



Cable Puller Packaging

Cable Pullers are packaged in sturdy, color coded cardboard boxes with a cutout window to display the product.

-  1-Ton Pullers
-  2-Ton Pullers
-  4-Ton Pullers



Standard Grade

- Dual stamped metal ratchet wheels
- High strength, electro-plated steel parts
- Galvanized 3/16" aircraft cable
- Drop forged steel slip hooks w/safety latches

Part Number	Description	Capacity (lbs)	Power Ratio	Take-up (ft/m)
96111	1-Ton Single Line	2,000	1:1	7' (2.2m)
96112	2-Ton Double Line	4,000	2:1	5' (1.5m)
96114	4-Ton Double Line	8,000	2:1	5' (1.5m)

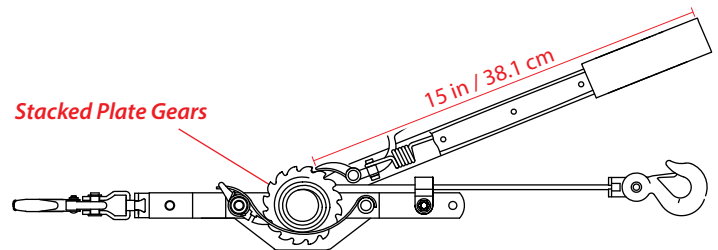
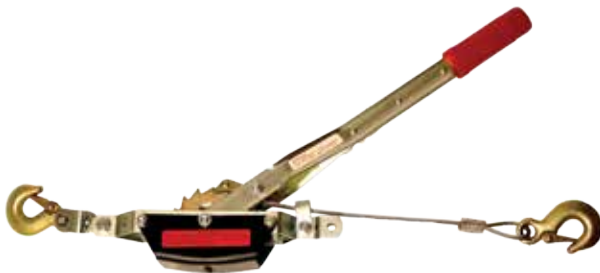

Professional Grade

Longer handle, larger hooks, thicker frame, and higher take-up than Standard Grade models.

- Dual machined one-piece gears
- High strength, electro-plated steel parts
- Galvanized 3/16" aircraft cable
- Drop forged steel slip hooks w/safety latches

Part Number	Description	Capacity (lbs)	Power Ratio	Take-up (ft/m)
96121	1-Ton Pro Single Line	2,000	1:1	12' (3.6m)
96122	2-Ton Pro Double Line	4,000	2:1	6' (1.8m)

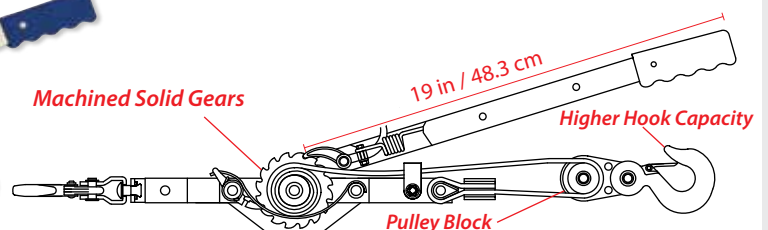

INSTALLATION ACCESSORIES

Specialty Pullers



96100 | 3/4 Ton Rope Puller

1,500 lbs Capacity (1,680 kg)
20FT Take-Up (6.0m)

- Single piece drive wheel
- High strength, electro-plated steel parts
- 1/2" Wear resistant twisted rope
- 20' Rope & hook assembly included
- Drop forged steel slip hooks w/safety latch
- Easily lower tree limbs
- Provides longer pull length

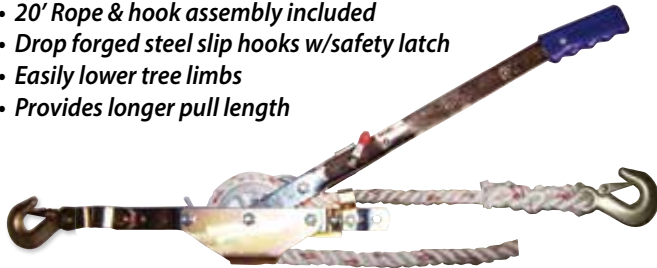

96101 | 1 Ton Strap Puller

2,000 lbs Capacity (907 kg)
12FT Take-Up (3.6m)

- Dual stamped metal ratchet wheels
- High strength, electro-plated steel parts
- 1" High strength webbing
- 12' Strap & hook assembly included
- Drop forged steel slip hooks w/safety latches on both ends
- Great for composite materials and decorative vinyl
- Lighter & easier to use than cable

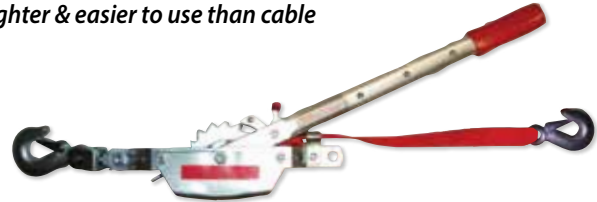

Fencing Installation Accessories



96140 | Fence Pliers

10" Length

- Forged jaws
- Integrated wire cutter
- Padded non-slip contoured grips for comfort and peak performance
- For use in cutting, bending, & tying wire fencing
- Great for barbed wire repairs
- Carded blister pack



96142 | Fence Pliers

12" Length

- Forged jaws
- Integrated wire cutter
- Padded non-slip contoured grips for comfort and peak performance
- For use in cutting, bending, & tying wire fencing
- Great for barbed wire repairs
- Carded blister pack



96147 | 1/2 Ton Wire Grip

1,000 lbs Capacity (454 kg)

- Works on smooth or barbed wire
- Handles wire 5/32" - 5/16" in diameter
- Corrosion resistant
- Lightweight zinc-plated steel
- Double sealed ratchet wheel brake system
- Carded blister pack



96148 | Woven Wire Stretcher

Quick & Even Stretching

- Makes fence repairs quick and easy
- Ideal for fast tightening
- Pull fence evenly and tightly
- For field and chain link fences
- Dependable design
- Bulk packaging



96149 | Fencing Wire Stretcher

With Control Release Ratchet

- Ideal for fast tightening
- Dependable design
- Makes fence repairs quick and easy
- For high-tensile, smooth and barbed wire
- Hardened guide and clamp grip wire firmly over a large area
- Bulk packaging



96146 | Gin Wheel

1,250 lbs WLL (567 kg)

- Accepts up to 1" diameter rope
- Heavy duty 12" cast iron sheave
- Forged steel swivel hook w/safety latch
- Blue powder coat finish
- Bulk packaging



ANATOMY OF A RATCHET STRAP

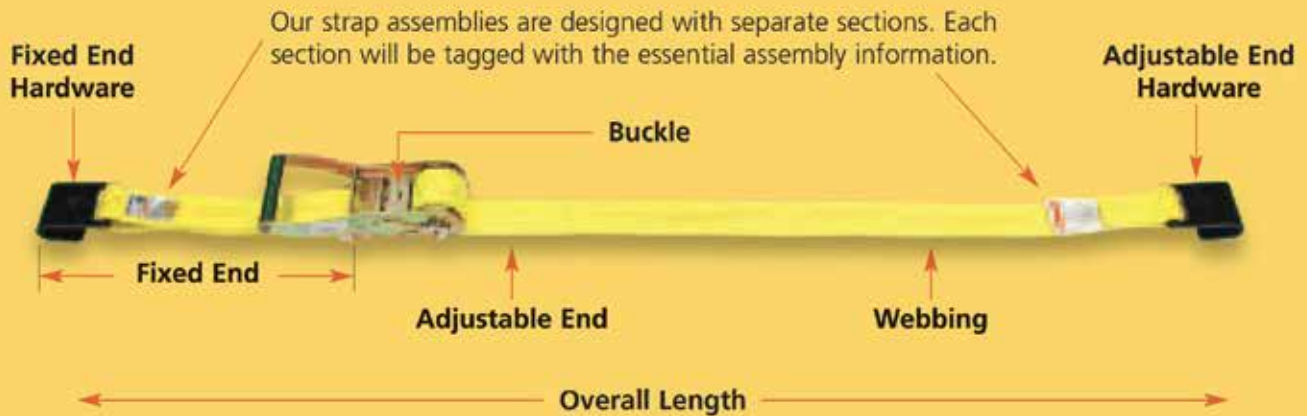

The distance between extreme end bearing points of the web tie down assembly, including the fittings. Standard fixed end length is 18" (33" for chain anchor straps). This puts the ratchet in the optimum position on the side of the trailer.

THE IMPORTANCE OF SECURING CARGO

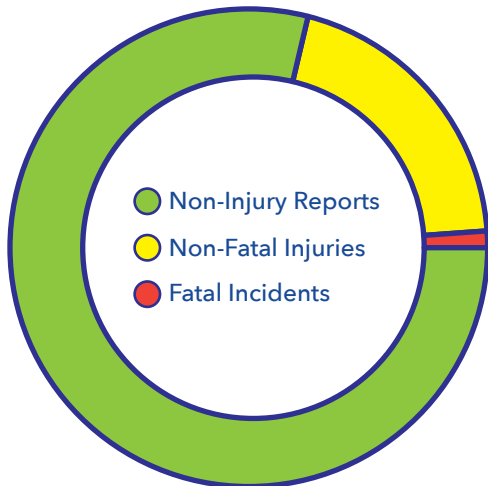

ROAD DEBRIS

ACCIDENT FATALITIES & INJURIES

From 2011 - 2014 there were more than 200,000 police-reported crashes that listed Road Debris as a factor. This resulted in approximately 39,000 involved injuries and 500 deaths.

$$20 \text{ lbs} + 55 \text{ mph} = 1,000 \text{ lbs}$$

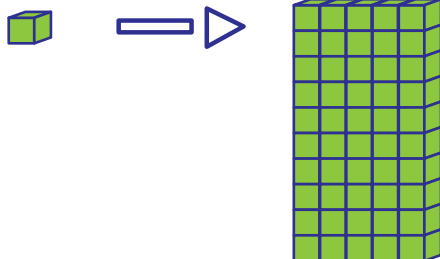

UNSECURED LOAD

STATE FINES & PENALTIES

All 50 U.S. States, plus the District of Columbia, have fines ranging from \$10-\$5,000 for loads that are not properly secure. At least 16 states also add possible imprisonment.



FORCE OF IMPACT

STATIONARY VS MOVING

A 20-pound object traveling at 55 mph hits with the force of 1,000 pounds at the time of impact.

TIE- DOWNS

INDUSTRIAL TIE-DOWNS

Industrial Strap Assembly Components

Tried & tested by professional truck drivers for 50 years, Ankra Industrial Grade ratchet straps are built for the most demanding applications. Quality, care and thought go into every strap ensuring our products perform as intended and outlast the competition. From full size long wide handle ratchets for easier grip and maximum leverage, to specialty coated webbings that provide additional UV and water resistance to big beefy end fittings matched to the strap's working load limit, you're certain to find the tie-down that fits your needs.

Tie-Downs

INDUSTRIAL

2" STANDARD WIDE HANDLE

- Dichromate finish
- 3.76" Aluminum grip
- 6.25" Handle
- 3,333 lbs WLL / 1,515 kg



2" LONG WIDE HANDLE

- Dichromate finish
- 3.76" Aluminum grip
- 8.5" Handle
- 3,666 lbs WLL / 1,662 kg



3" LONG WIDE HANDLE

- Dichromate finish
- 4.8" Aluminum grip
- 10.5" Handle
- 7,333 lbs WLL / 3,326 kg



4" LONG WIDE HANDLE

- Dichromate finish
- 5.2" Aluminum grip
- 12.5" Handle
- 8,000 lbs WLL / 3,628 kg



STANDARD HIGH CAPACITY WEBBING (SHC)



- Latex coated polyester with excellent UV protection and abrasion resistance
- Meets DOT and WSTDA requirements

X-TREME™ HIGH CAPACITY WEBBING (X-TREME)



- Polyester webbing with superior weave pattern and permanent proprietary coating that provides twice the abrasion resistance of standard high capacity webbing and greater resistance to damaging water absorption
- Meets DOT and WSTDA requirements



Flat Hook with Aluminum Edge Guard



Wire Double J-Hook



Twisted Snap Hook



Chain Anchor

Heavy Duty Merchandising

556 Series | Standard Wide Handle Ratchets

All 556 series tie-downs are packaged in color-coded 9-piece display bins. Fits nicely on a 14 inch gondola shelf & can be neatly stacked for end-caps or floor displays.

BEST CHOICE FOR CONTRACTOR OR DIY USE



556



556-WHK



556 Display Box

INDUSTRIAL TIE-DOWNS

2^{IN} Strap | Standard Wide Handle 3,333 lbs WLL (1,515 kg)

Part Number	Length (Feet)	Hook Type	Webbing Type
556	27'	Flat	SHC
556-WHK	27'	Wire Double-J	SHC

2^{IN} Strap | Long Wide Handle 3,333 lbs WLL (1,515 kg)



Part Number	Length (Feet)	Hook Type	Webbing Type
557-15	15'	Flat	SHC
557-15WHK	15'	Wire Double-J	SHC
557	27'	Flat	SHC
45982-90-27	27'	Flat	X-TREME
557-WHK	27'	Wire Double-J	SHC
45982-95-27	27'	Wire Double-J	X-TREME
45982-19	27'	Twisted Snap	SHC
45982-15	27'	Chain Anchor	SHC
45982-11	30'	Flat	SHC
45982-90-30	30'	Flat	X-TREME
45982-43	30'	Wire Double-J	SHC
45982-95-30	30'	Wire Double-J	X-TREME
45982-36	30'	Twisted Snap	SHC
45982-34	30'	Chain Anchor	SHC
557-40	40'	Flat	SHC
557-40WHK	40'	Wire Double-J	SHC
557-50	50'	Flat	SHC
557-50WHK	50'	Wire Double-J	SHC
557-60	60'	Flat	SHC
557-60WHK	60'	Wire Double-J	SHC

3^{IN} Strap | Long Wide Handle 5,400 lbs WLL (2,450 kg)



Part Number	Length (Feet)	Hook Type	Webbing Type
48987-20	27'	Flat	SHC
48987-90-27	27'	Flat	X-TREME
48987-28	27'	Wire Double-J	SHC
48987-24	27'	Chain Anchor	SHC
48987-92-27	27'	Chain Anchor	X-TREME
48987-21	30'	Flat	SHC
48987-90-30	30'	Flat	X-TREME
48987-29	30'	Wire Double-J	SHC
48987-25	30'	Chain Anchor	SHC
48987-92-30	30'	Chain Anchor	X-TREME

4^{IN} Strap | Long Wide Handle 5,400 lbs WLL (2,450 kg)



Part Number	Length (Feet)	Hook Type	Webbing Type
49346-10	27'	Flat	SHC
49346-90-27	27'	Flat	X-TREME
49346-12	27'	Wire Double-J	SHC
49346-93-27	27'	Wire Double-J	X-TREME
49346-14	27'	Chain Anchor	SHC
49346-91-27	27'	Chain Anchor	X-TREME
49346-11	30'	Flat	SHC
49346-90-30	30'	Flat	X-TREME
49346-13	30'	Wire Double-J	SHC
49346-93-30	30'	Wire Double-J	X-TREME
49346-15	30'	Chain Anchor	SHC
49346-91-30	30'	Chain Anchor	X-TREME

All Products listed on this page are Bulk Packaged, Retail Quantity of 1, with Tri-Lingual Warning Tags.
Note: Standard webbing color for heavy duty tie-downs is yellow unless noted by color block next to the part number.



CONSUMER TIE-DOWNS

Tie-Downs

CONSUMER

General use tie-downs are designed to provide dependability at a great value. We recommend offering a mix of Series X and SL Series tie-downs to accommodate a wider range of customer applications and preferences.



BEST SELLER

SL91 | 4 Pack 15' x 1" Ratchet

- 15' Length
- 500 lbs Working Load Limit (WLL)
- Fully curved vinyl covered S-hooks
- Padded grip ratchet handles
- Interactive open style package



Packaged Tie-Downs



SL27 | 4 Pack

6' x 1" Cam Buckle
WLL: 300 lbs (135 kg)

- Compact vinyl coated S-hooks



SL66 | 4 Pack

8' x 1" Ratchet - Camo
WLL: 400 lbs (181 kg)

- Padded grip handle
- Compact vinyl coated S-hooks



SL16 | 4 Pack

10' x 1" Ratchet
WLL: 300 lbs (135 kg)

- Compact vinyl coated S-hooks



SL38 | 2 Pack

6' x 1" Cam Buckle
WLL: 400 lbs (181 kg)

- Full size vinyl coated S-hooks



SL30 | 2 Pack

6' x 1" Ratchet
WLL: 400 lbs (181 kg)

- ATV/Cycle strap
- Full size vinyl coated S-hooks



SL01 | 1 Pack

10' x 1" Cam Buckle
WLL: 400 lbs (181 kg)

- Full size vinyl S-hooks



SL05 | 2 Pack

10' x 1" Ratchet
WLL: 300 lbs (135 kg)

- Yellow chromate ratchet
- Full size vinyl coated S-hooks



SL48 | 2 Pack

13' x 1" Lashing
WLL: 200 lbs (91 kg)

- Great for bundling & roof racks
- Loop style - no hooks



SL47 | 1 Pack

13' x 1" Endless Ratchet
WLL: 300 lbs (135 kg)

- Great for roof racks
- Forms a loop - no hooks



SL46 | 1 Pack

13' x 1" Ratchet
WLL: 300 lbs (135 kg)

- Black powder coated ratchet
- Compact vinyl S-hooks



SL18 | 1 Pack

14' x 1" Ratchet
WLL: 400 lbs (181 kg)

- Black powder coated ratchet
- Full size vinyl coated S-hooks



SL32 | 1 Pack

15' x 1.5" Ratchet
WLL: 1,666 lbs (756 kg)

- Wide short handle w/aluminum grip
- Double J-hooks
- Heavy duty webbing



CONSUMER TIE-DOWNS

SL81 | 2 Pack

16^{FT} x 1.25^{IN} Ratchet
WLL: 700 lbs (318 kg)

- Vinyl coated double J-hooks
- 1.25" Heavy duty ratchet
- Molded grip handle



SL100 | 1 Pack

16^{FT} x 1^{IN} Ratchet
WLL: 1,000 lbs (454 kg)

- 1" Heavy duty ratchet
- Double J-hooks
- Floating D-ring



SL101 | 1 Pack

16^{FT} x 1.5^{IN} Ratchet
WLL: 1,666 lbs (756 kg)

- Wide handle w/aluminum grip
- Double J-hooks
- Heavy duty webbing



SL102 | 2 Pack

16^{FT} x 1.5^{IN} Ratchet
WLL: 1,666 lbs (756 kg)

- Wide handle w/aluminum grip
- Double J-hooks
- Heavy duty webbing



XH8088-2P | 2 Pack

Bull Ring - Retractable Stake Pocket Anchor



- Black nylon cover
- Stainless steel ring
- Snaps up/snaps down
- No drill 60 second installation
- Capacity: 1,000 lbs



Fits: Ford F Series (1998-2014)
6.5' & 8' beds with snap out covers on rail caps.

Ford F Series (2015 & Newer)
Fits over top of rail cap only.

Ford F Ranger (2000-2012)

Chevy/GMC (1999-2013)
Excludes 3500

Dodge Ram (1995-2017)

Excludes Laramie & Ram box. 2009-2017 Rail cap modification required.

Bulk Bin Program

Durable polyester web tie-downs individually shrink wrapped and labeled for resale. Packaged in full-color pop-up display bins for convenient merchandising.



Part Number	Length (Feet)	Width (Inches)	Working Load Limit (lbs)	Buckle Type	End Hardware	Webbing Color
95180	13	1	200	Cam Buckle	None (Lashing Strap)	Black
95181	10	1	300	Ratchet	S-Hooks	Red
95182	13	1	300	Ratchet	None (Lashing Strap)	Yellow
95183	6	1	400	Cam Buckle	S-Hooks	Red
95184	6	1	400	Cam Buckle	S-Hooks	Camo
95185	6	1	400	Ratchet	S-Hooks	Red
95186	6	1	400	Ratchet	S-Hooks	Camo
95187	10	1	400	Cam Buckle	S-Hooks	Blue
95188	14	1	400	Ratchet	S-Hooks	Blue
95189	15	1	500	Ratchet	S-Hooks	Orange
95190	15	1	500	Ratchet	S-Hooks	Camo
95191	15	1	600	Ratchet	J-Hooks with D-Rings	Blue
95192	16	1	1,000	Ratchet	J-Hooks with D-Rings	Black
95193	16	1.5	1,600	Ratchet	J-Hooks	Yellow
95194	13	5/8	3,500 (MVW)	Recovery Rope	Slip Hooks	Yellow
95391	27	2	3,333	Retractable Ratchet	J-Hooks	Yellow

CONSUMER / COMMERCIAL TIE-DOWNS

Perhaps the highest quality general application tie-downs on the market, our "X" series straps are packed full of features and conveniences and built to endure the rigorous applications of today's professional contractor, light industrial user and avid motorsports enthusiasts. "X" series products are made with heavy duty abrasion resistant polyester webbing and packaged in environmentally conscious and easy to merchandise display boxes that are completely recyclable.

Tie-Downs

CONSUMER / COMMERCIAL

Cam Buckle Tie-Downs



XC108-2P | Motorsports | 2 Pack

8FT x 1.25IN Cam Buckle
WLL: 400 lbs (181 kg)

- Pre-threaded & ready to use
- Soft-tie option built-in
- Full size vinyl coated hooks with keepers
- Sewn loop end to prevent pull through



XC012-1P | General Purpose | 1 Pack

12FT x 1IN Cam Buckle
WLL: 400 lbs (181 kg)

- Full size vinyl S-hooks
- Sewn loop end to prevent pull through



Ratchet Tie-Downs



XR108-2P | Motorsports | 2 Pack

8FT x 1.25IN Ratchet
WLL: 700 lbs (318 kg)

- Pre-threaded & ready to use
- Soft-tie option built-in
- Spring loaded webbing storage clamp
- Full size vinyl coated hooks with keepers
- Sewn loop end to prevent pull through



XR015-1P | General Purpose | 1 Pack

15FT x 1IN Ratchet
WLL: 500 lbs (227 kg)

- Molded grip ratchet handle
- Full size vinyl coated hooks



XR015-4P | General Purpose | 4 Pack

15FT x 1IN Ratchet
WLL: 500 lbs (227 kg)

- Molded grip ratchet handle
- Full size vinyl coated hooks



XR015-C1P | General Purpose | 1 Pack

15FT x 1IN Ratchet - Camo
WLL: 500 lbs (227 kg)

- Molded grip ratchet handle
- Full size vinyl coated hooks



XR115-C2P | General Purpose | 2 Pack

15FT x 1.25IN Ratchet - Camo
WLL: 700 lbs (318 kg)

- Spring loaded webbing storage clamp
- Full size vinyl coated hooks with keepers
- Extended 19" fixed end to extend ratchet above pick-up rail
- Sewn loop end to prevent pull through



CONSUMER / COMMERCIAL TIE-DOWNS

Retractable Ratchets



95370 | 2 Pack

6' x 1" Ratchet
WLL: 500 lbs (227 kg)

- Push button control



95371 | 2 Pack

10' x 1" Ratchet
WLL: 500 lbs (227 kg)

- Gear spring design restricts accelerated retraction



95372 | 2 Pack

15' x 1" Ratchet
WLL: 500 lbs (227 kg)

- Gear spring design restricts accelerated retraction



95380 | 1 Pack

4' x 1 7/8" Ratchet
WLL: 1,000 lbs (454 kg)

- Bolt-on style
- For utility trailers and ladder racks
- Mounting hardware included



95381 | 1 Pack

4' x 1 7/8" Ratchet
WLL: 550 lbs (249 kg)

- Bolt-on style
- For boat trailers, utility trailers and ladder racks
- Mounting hardware included

STAINLESS STEEL



95382 | 1 Pack

10' x 1 7/8" Ratchet
WLL: 1,000 lbs (454 kg)

- Bolt-on or use standard style
- For utility trailers and ladder racks
- Includes hardware and fixed end option



95391 | 1 Pack

27' x 2" Ratchet
WLL: 3,333 lbs (1,515 kg)

- Gear spring design restricts accelerated retraction
- Packed in bin style carton



Commercial Grade Tie-Downs



APS-3 | Heavy Duty | Contractor Grade

12' x 1" Ratchet
WLL: 1,000 lbs (454 kg)

- 3,500 lbs polyester webbing
- Yellow chromate ratchet
- Yellow chromate double J-hooks with floating D-rings on both ends



APS-15192 | Standard Duty

16' x 1" Ratchet
WLL: 500 lbs (227 kg)

- 2,000 lbs polyester webbing
- Yellow chromate ratchet
- Full size vinyl coated hooks



10936 Series | Heavy Duty | Contractor Grade

1" Ratchet
WLL: 1,000 lbs (454 kg)

- 1" Black polyester webbing
- Wide grip yellow chromate ratchet
- Full size vinyl coated S-hooks
- Bulk packed, rolled, plastic banded, and UPC coded
- Packed in shelf merchandiser box
- 15" Fixed end
- 6', 12', 16', and 20' options
- Tri-lingual warning tags



Part Number	Length (Feet)
10936-06	6'
10936-12	12'
10936-16	16'
10936-20	20'

MOTORSPORTS

Cam Buckle

Tie-Downs

MOTORSPORTS

49494-212 | Integra Big Bike Cam | 2 Pack
66^{IN} x 1.5^{IN} Cam Buckle with S-Hooks & Integrated Soft Hook
700 lbs WLL (318 kg)

- Integrated soft hook
- Heavy duty cam buckle with pressure plate
- Full size vinyl coated S-hooks
- Durable 1.5" nylon webbing



47295 Series | Ancra Lites | 2 Pack
66^{IN} x 1^{IN} Cam Buckle with S-Hooks
330 lbs WLL (150 kg)

- 3,800 lbs tensile strength nylon webbing
- 1,500 lbs rated cam buckle
- 2 S-hooks per strap, rated at 1,200 lbs each
- 1 Vinyl coated S-hook, 1 plated S-hook



Part Number	Color
47295-10	Black
47295-11	Red
47295-12	Blue
47295-14	Orange
47295-16	Lime Green

40888 Series | The Original | 2 Pack
66^{IN} x 1^{IN} Cam Buckle with S-Hooks
400 lbs WLL (181 kg)

- 4,500 lbs tensile strength nylon webbing
- 1,800 lbs rated heavy duty cam buckle with pressure plate
- 2 Vinyl coated S-hooks per strap, rated at 1,200 lbs each



Part Number	Color
40888-10	Red
40888-26	Black
40888-34	Blue

49380 Series | Integra | 2 Pack
69^{IN} x 1^{IN} Cam Buckle with S-Hooks & Integrated Soft Hook
400 lbs WLL (181 kg)

- 4,500 lbs tensile strength nylon webbing
- 1,800 lbs rated heavy duty cam buckle with pressure plate
- 2 S-hooks per strap, rated at 1,200 lbs each



Part Number	Color
49380-10	Red
49380-11	Black
49380-12	Blue

Ratchet Straps

49970-102 | Integra Big Bike Gradual Release Ratchet* | 2 Pack
 66" x 1" Ratchet with S-Hooks & Integrated Soft Hook
 800 lbs WLL (363 kg)

- Patented gradual release ratchet
- Wide easy grip ratchet handle
- Durable 1.5" nylon webbing
- Full size vinyl coated S-hooks
- Positive locking latch

*Gradual release ratchet allows the tension to be let out slowly, instead of unloading rapidly



47439 Series | Rat Pak™ | 2 Pack
 66" x 1" Ratchet with S-Hooks
 400 lbs WLL (181 kg)

- 4,500 lbs tensile strength nylon webbing
- 4,400 lbs rated ratchet
- 2 Vinyl coated S-hooks per strap, rated at 1,200 lbs each



Part Number	Color
47439-10	Red
47439-11	Black

49498 Series | Integra Rat Pak™ | 2 Pack
 69" x 1" Ratchet with S-Hooks & Integrated Soft Hook
 400 lbs WLL (181 kg)

- 4,500 lbs tensile strength nylon webbing
- 4,400 lbs rated ratchet
- 2 Vinyl coated S-hooks per strap, rated at 1,200 lbs each



Part Number	Color
49498-10	Red
49498-11	Black
49498-12	Blue

Accessories

49603-10 | Trackstar® Motorcycle Wheelchock

- Fits 3.5" - 5.5" tires
- Quick connect to aircraft style O-track
- Comes complete with mounting kit



49288-10 | Trackstar® Accessory Mounting Kit

- For installation in a second vehicle or garage floor



45214 Series | Soft Hook Extensions | 2 Pack
 400 lbs WLL (181 kg)

- Protect paint & chrome attachment surfaces
- Eliminates metal-to-metal contact
- 3,800 lbs tensile strength nylon webbing



Part Number	Length (Inches)	Color
45214-10	18"	Black
45214-12	18"	Orange
45214-13	18"	Lime Green
45214-25	18"	Red
45214-26	18"	Blue



AUTOMOTIVE TIE-DOWNS

Tire Bonnets

- Premium 2" coated webbing for greater abrasion resistance
- Twisted snap hook on fixed end
- Short handle ratchet with built-in snap hook
- Packaged in window box – 1 assembly per box
- 3,333 LBS WLL (1,515 kg)

Made in USA 

Tire Bonnets can be special ordered with flat hooks in place of Snap Hooks. Contact Customer Service for pricing and availability.

Tie-Downs

AUTOMOTIVE

30TB | Standard Fixed
14" - 15" OEM Tires
No Ratchet



30TB-MS | Standard Fixed
14" - 15" OEM Tires
With Ratchet



30ATB* | Adjustable
13" - 17" OEM Tires
No Ratchet



*30ATB also available in Blue (-BL)

30ATB-MS-BK* | Adjustable
13" - 17" OEM Tires
With Ratchet



*30ATB-MS also available in Yellow (-YL), Blue (-BL), Gray (-GR), Red (-RD) & Orange (-OR).

30RT-BL* | Double Adjustable
13" - 17" OEM Tires
10" - 22" OEM Tires
With Ratchet



*30RT also available in Yellow (-YL), Black (-BK), Red (-RD) & Orange (-OR)

Basket & Dolly Straps

45143-20 | Basket Strap
1,666 lbs WLL (755 kg)

- For tires 7" w x 20" h
- Weight: 2.25 lbs
- Bulk packaged
- No ratchet



47934-11 | Wheel Dolly Strap
900 lbs WLL (410 kg)

- 2" x 86" With round ring
- For tires 8" w x 22" h
- Weight: 1.0 lbs
- Bulk packaged
- No ratchet



47935-11 | Wheel Dolly Strap
800 lbs WLL (360 kg)

- With S-hooks
- For tires 10" w x 24" h
- Weight: 1.5 lbs
- Bulk packaged
- No ratchet



AUTOMOTIVE TIE-DOWNS

Vehicle Tie-Downs



- 2" Coated webbing for greater abrasion resistance
- Twisted snap hooks
- Wide handle ratchet
- 3,333 lbs WLL (1,515 kg)
- Packaged in merchandiser box

Part Number	Description	Length (Feet)	Color
500-C6-RD	Strap Assembly	6'	Red
500-C8-BK	Strap Assembly	8'	Black
500-C8-RD	Strap Assembly	8'	Red
500-C8-BL	Strap Assembly	8'	Blue
500-C10-BK	Strap Assembly	10'	Black

500-C6-RD
500-C8-RD



500-C8-BK
500-C10-BK



500-C8-BL



Series E Transit Strap | RTJ Hooks

Assembled with durable latex treated polyester webbing and short-wide handle ratchet. Fixed end features a heavy duty Series E & A track fitting and the adjustable end features a cluster hook with R, T & J options.



Part Number	Length (Feet)	Working Load Limit (lbs)	Working Load Limit (kgs)
49023-20	6'	1,000	455
49023-21	8'	1,000	455
49023-22	12'	1,000	455

48487-24 | Auto Hauler Winch Strap

2" x 140" Winch Strap With Cleats
3,333 lbs WLL (1,515 kg)



The auto tie-down strap goes over the tire and utilizes three cleated rubber pads that mesh with the tread to keep the strap centered and secured.

500-RAS-BK | Made in the USA

8' Tie Back Strap with Integrated Axel Strap
3,300 lbs WLL (1,497 kg)

- Heavy duty twisted snap hooks
- Stamped D-ring
- Adjustable loop size
- Cordura protective sleeve
- Includes wide handle ratchet with 9" fixed end



Axel Straps | Made in the USA

3,333 lbs WLL (1,515 kg)

- 2" Coated webbing for greater abrasion resistance
- Stamped D-rings
- Cordura protective sleeve
- Bulk packaging – individually UPC coded



Part Number	Length (Feet)	Color
30AS21-BK	21"	Black
30AS21-RD	21"	Red
30AS21-BL	21"	Blue
30AS33-BK	33"	Black
30AS33-RD	33"	Red
30AS33-BL	33"	Blue

EVENT TENT PRODUCTS

Tie-Downs

TENT STRAPS

The last thing you want to worry about is the security of your tent on that special occasion. Ancra tent straps and bungee balls are made with high quality materials that are built to last and provide stability even under extreme pressure. Our white tent straps work on most party tents and keep tents secure even in high wind conditions. Straps come in a variety of lengths and widths with a wide selection of hardware to ensure your tent stays tied down. With a large range of options to choose from, you're certain to find the most reliable, cost effective solution possible.

All Ancra tent straps feature:

- Clear zinc coated hardware
- Premium latex coated white polyester webbing



Ratchet Straps | Wide Handle

1" x 15' Ratchet

WLL: 1,000 lbs (3,000 lbs Break Strength)

- Bulk banded
- Box quantity 8

Part Number	Fixed End	Adjustable End
96011	Double J-Hooks	Double J-Hooks
96012	Double D-Hooks	Double D-Hooks
96013	Snap Hooks	Snap Hooks
96014	Twisted Loop	Double J-Hooks

Ratchet Straps | Wide Handle

2" x 20' Ratchet

WLL: 2,000 lbs (6,000 lbs Break Strength)

- Bulk banded
- Box quantity 6

Part Number	Fixed End	Adjustable End
96021	Double J-Hooks	Double J-Hooks
96022	Double D-Hooks	Double D-Hooks
96023	Snap Hooks	Snap Hooks
96024	Twisted Loop	Double J-Hooks

Ratchet Straps | Long/Wide Handle

2" x 27' Ratchet

WLL: 3,333 lbs (10,000 lbs Break Strength)

- Bulk banded
- Box quantity 6

Part Number	Fixed End	Adjustable End
96031	Double J-Hooks	Double J-Hooks
96032	Twisted Loop	Double J-Hooks

Cam Buckle | Silver Buckle

1.5" x 15' Strap

WLL: 1,000 lbs (3,000 lbs Break Strength)

- Bulk banded
- Box quantity 8

Part Number	Fixed End	Adjustable End
96041	S-Hook w/Clip	S-Hook w/Clip & Soft Loop

Canopy Ties | White Ball

- Polybag/header
- Box quantity 5



Part Number	Size	Number Per Package
96061	6"	20
96062	10"	10

Clear Zinc Hardware



HEAVY DUTY

WINCH STRAPS

Winch Straps

Webbing Types

Standard High Capacity Webbing (SHC)



- Latex coated polyester with excellent UV protection and abrasion resistance
- Meets DOT and WSTDA requirements

X-TREME™ High Capacity Webbing



- Polyester webbing with superior weave pattern and permanent proprietary coating that provides twice the abrasion resistance of standard high capacity webbing and greater resistance to damaging water absorption
- Meets DOT and WSTDA requirements

End Hardware



Chain End



Delta Ring



Flat Hook



Grab Hook



Sewn Loop



Wire Hook

2^{IN} Straps | SHC

3,333 lbs WLL (1,515 kg)

- Bulk packaged
- Retail pack quantity 1
- Tri-lingual warning tags

Part Number	Length (Feet)	Hook Type
41659-10-27	27'	Flat
41659-13-27	27'	Wire Hook
41659-10-30	30'	Flat
41659-13-30	30'	Wire Hook
41659-11-30	30'	Delta Ring



3^{IN} Straps | SHC

5,400 lbs WLL (2,450 kg)

- Bulk packaged
- Retail pack quantity 1
- Tri-lingual warning tags

Part Number	Length (Feet)	Hook Type
41660-10-30	30'	Flat
41660-14-30	30'	Chain Anchor



4^{IN} Straps | SHC

5,400 lbs WLL (2,450 kg)

- Bulk packaged
- Retail pack quantity 1
- Tri-lingual warning tags

Part Number	Length (Feet)	Hook Type
43795-10-27	27'	Flat
43795-10-30	30'	Flat
43795-10-40	40'	Flat
43795-10-50	50'	Flat
43795-10-60	60'	Flat
43795-11-30	30'	Delta Ring
43795-13-30	30'	Sewn Loop
43795-14-30	30'	Grab Hook
43795-15-30	30'	Chain Anchor
214-30KP	30'	Flat w/Keeper



4^{IN} Straps | X-TREME™

5,400 lbs WLL (2,450 kg)

- Bulk packaged
- Retail pack quantity 1
- Tri-lingual warning tags

Part Number	Length (Feet)	Hook Type
43795-90-30	30'	Flat
43795-90-40	40'	Flat
43795-95-30	30'	Chain Anchor



Heavy Duty

WINCH STRAPS

WINCHES & WINCH BARS

Winches

Ancra winches comply with DOT, WSTDA-T3 and Canadian Standard 905 regulations. Available in different base configurations to suit a variety of needs and load requirements.

All winches shown are right hand models. Left hand models may be available on special orders.

- Powder coating withstands 250 hours of standard salt spray testing to ensure years of service
- Stamped working load limit and Ancra name certify quality
- High-strength alloy pawl pins
- Seamless solid steel mandrel
- Smooth ground web slots prevent web wear

Part Number	Winch Type	Surface Treatment	Working Load Limit (Lbs)	Attachment	Mount Placement
43563-10	Standard	Black Lacquer	5,500	Weld-On	Bottom
43564-147	Portable	Black Powder Coat	5,500	Bolt-On	Side Frame
43564-167	Portable	Powder Coat	5,500	Bolt-On	Side Frame
43565-127	Storable	Powder Coat	5,500	Slider	C-Track
43573-10	Storable	Black Lacquer	5,500	Weld-On	Bottom
43579-20	Low Profile	Black Lacquer	5,500	Weld-On	Bottom
47640-31	Lashing	Black Lacquer	3,333	Bolt-on/Weld-on	Side Frame
49207-137	Storable	Black Powder Coat	5,500	Slider	Double L-Track



- 49716-10 | Porta Winch - Outward Offset
- 49716-11 | Porta Winch - Inward Offset
- 5,500 lbs WLL (2,500 kg)
- Installs easily without tools
- Fasten straps securely and legally
- Inserts into standard trailer stake pockets



- 49723-10 | SilverCap OverDrive®
- 5,500 lbs WLL (2,500 kg)

- Converts standard winches to ratcheting winches
- Works with weld-on, sliding, or portable mount winches



Winch Bars

All winch bars are made from heat treated steel for extra strength and designed for use with standard winch caps. Each bar has a knurled handle in two sections for improved grip and a flanged mushroom tip end to keep the bar from slipping within the winch cap.

- 42313-12 | 34" Combination Box End
- Painted silver & yellow finish • Chain binder release end



- 42313-10 | 34" Standard Black | Black powder coat finish



- 42313-17 | 34" Standard Chrome | Chrome finish



- 42313-19 | 34" Combination Chrome
- Chrome finish • Open ended



ErgoBar

Made from heat treated steel for extra strength and designed for use with standard winch caps. The patented ergonomic bend in the bar allows it to be easily rotated without removal from the winch cap maintaining parallel alignment of the handle and providing optimum leverage with less strain on the operator. Each bar also has a knurled handle in the lead section for improved grip and a flanged mushroom tip end to keep the bar from slipping.

- 50015-10 | 34" ERGO 360° Standard



- 50015-20 | 34" ERGO 360° Combination
- Open ended



- 50015-21 | 34" ERGO 360° Combination Box End
- Chain binder release end



TRANSPORT CHAIN

Transport Chain Assemblies

Grade 43 | Chain Assemblies

3/8^{IN} Chain

5,400 lbs WLL (2,449 kg)

- High strength carbon steel
- Great for general tie-down use & logging
- Packed in polybag with upc and warning label, 10 per drum
- Chain links marked per NACM standards every 6 inches
- NOTE: Not for overhead lifting



Part Number	Length (Feet)	Package Type
49958-38-20	20'	drum/bag
49958-38-20-SP	20'	plastic tub

Grade 70 | Chain Assemblies

- High strength carbon alloy steel
- Zinc plated gold chromate for corrosion resistance
- Clevis hooks made of heat treated alloy steel
- Designed for over-the-road transportation
- Chain links marked per NACM standards every 6 inches
- Packed in polybag with upc and warning label, 10 per drum
- NOTE: Not for overhead lifting

5/16^{IN} Chain

4,700 lbs WLL (2,132 kg)

Part Number	Length (Feet)	Package Type
45881-10-16	16'	drum/bag
45881-10-16-SP	16'	plastic tub
45881-10-20	20'	drum/bag
45881-10-20-SP	20'	plastic tub
45881-10-25	25'	drum/bag
45881-10-25-SP	25'	plastic tub

Color Coded Barrels for Easier Identification!



Also available in single piece stackable and reusable plastic storage tub. (SP)



3/8^{IN} Chain

6,600 lbs WLL (2,994 kg)

Part Number	Length (Feet)	Package Type
45881-11-16	16'	drum/bag
45881-11-16-SP	16'	plastic tub
45881-11-20	20'	drum/bag
45881-11-20-SP	20'	plastic tub
45881-11-25	25'	drum/bag
45881-11-25-SP	25'	plastic tub

1/2^{IN} Chain

11,300 lbs WLL (5,126 kg)

Part Number	Length (Feet)	Package Type
45881-13-20	20'	drum/bag
45881-13-25	25'	drum/bag

Grade 70 | XHD Chain Assembly

3/8^{IN} Chain

6,600 lbs WLL (2,994 kg)

- High strength carbon alloy steel
- Zinc plated gold chromate for corrosion resistance
- Grade 80 clevis hooks made of heat treated alloy steel
- Designed for over-the-road transportation
- Chain links marked per NACM standards every 6 inches
- Stamped aluminum Working Load Limit tag
- Individually UPC coded, packed in heavy duty cardboard box
- NOTE: Not for overhead lifting



19% more material in the neck for added strength

Part Number	Length (Feet)	Package Type
50364-38-10	10'	box
50364-38-20	20'	box

50378-10-10 | Grade 80 J-Hook Chain Assembly

3/8^{IN} x10^{FT}

7,100 lbs WLL (3,221 kg)

- Lightweight performance alloy chain
- Large 15" J-hook and G80 clevis hook
- Great for securing large equipment
- Stamped aluminum Working Load Limit tag
- Chain links marked per NACM standards every 6 inches
- Individually UPC coded, packed in heavy duty cardboard box
- NOTE: Not for overhead lifting



50529-11-10-BX | Grade 100 Chain Assembly

3/8^{IN} x10^{FT}

8,800 lbs WLL (4,000 kg)

- Heat treated high carbon alloy steel
- Rugged black lacquer finish
- Complies with NACM standards
- Blue powder coated clevis grab hooks
- Stamped aluminum Working Load Limit tag
- Individually UPC coded, packed in heavy duty cardboard box
- NOTE: Not for overhead lifting



TRANSPORT CHAIN & CHAIN HARDWARE

Grade 70 Bulk Chain (No Hooks)

45880-12

1/4" x 400'FT
3,150 lbs WLL (1,430 kg)



45880-10

5/16" x 400'FT
4,700 lbs WLL (2,133 kg)



45880-11

3/8" x 200'FT
6,600 lbs WLL (2,996 kg)



45880-13

1/2" x 100'FT
11,300 lbs WLL (5,130 kg)



Chain Links marked per NACM Standards every 6 inches. NOTE: Not for overhead lifting.

Hooks

Clevis Hooks | Grade 70

- Forged & heat treated
- Individually polybagged with UPC
- Retail pack quantity 1



Part Number	Size (Inches)	Working Load Limit (lbs)	Working Load Limit (kgs)
45946-12	1/4"	3,150	1,430
45946-10	5/16"	4,700	2,133
45946-11	3/8"	6,600	2,996
45946-13	1/2"	11,300	5,130

Slip Hooks | Grade 70

- Forged steel with zinc plated gold chromate
- Individually polybagged with UPC
- Retail pack quantity 1



Part Number	Size (Inches)	Working Load Limit (lbs)	Working Load Limit (kgs)
50019-10	1/4"	3,150	1,430
50019-11	5/16"	4,700	2,133
50019-12	3/8"	6,600	2,996
50019-13	1/2"	11,300	5,130

Slip Hooks with Safety Latch | Grade 70

- Forged steel with zinc plated gold chromate
- Individually polybagged with UPC
- Retail pack quantity 1



Part Number	Size (Inches)	Working Load Limit (lbs)	Working Load Limit (kgs)
50019-20	1/4"	3,150	1,430
50019-21	5/16"	4,700	2,133
50019-22	3/8"	6,600	2,996
50019-23	1/2"	11,300	5,130

Chain Fittings

Shackles | Galvanized

- Screw pin style
- Individually polybagged with UPC
- Retail pack quantity 1



Part Number	Size (Inches)	Working Load Limit (lbs)	Working Load Limit (kgs)
50013-31	5/16"	1,500	681
50013-38	3/8"	2,000	900
50013-44	7/16"	3,000	1,362
50013-50	1/2"	4,000	1,816
50013-63	5/8"	6,500	2,951
50013-75	3/4"	9,500	4,313
50013-88	7/8"	11,300	5,125

Quick Links | Zinc Plated

- Individually polybagged with UPC
- Retail pack quantity 1



Part Number	Size (Inches)	Working Load Limit (lbs)	Working Load Limit (kgs)
50016-25	1/4"	880	399
50016-31	5/16"	1,760	799
50016-38	3/8"	2,200	998

CHAIN BINDERS

Chain Binders

All traditional chain load binders are constructed of drop forged steel for strength and durability and are designed for use with Grade 70 transport chain. They are available in traditional Lever, Recoilless and Ratcheting models, and are finished in an E-coat paint. They meet or exceed WSTDA T-6 standards.

Mini Chain Tighteners

- Retail pack 1
- Bulk packaged with UPC

Part Number	Finish	Working Load Limit (lbs)
50025-08	Clear Zinc	175
50025-09	E-Coat	250
50025-10	E-Coat	375



50025-09
50025-10



50025-08

Standard Lever | Drop Forged Steel Construction

- Retail pack 1
- Bulk packaged with UPC

Part Number	Size (Inches)	Working Load Limit (lbs)
45943-12	1/4" - 5/16"	2,600
45943-10	5/16" - 3/8"	5,400
45943-10HD	5/16" - 3/8"	6,600
45943-14*	5/16" - 3/8"	5,400
45943-11	3/8" - 1/2"	9,200
45943-13	1/2" - 5/8"	13,000



* Recoilless Lever Chain Binder

Standard Ratchet | Built-in Thread Safety Stops

- 1 piece handle pinned barrel
- Retail pack 1
- Bulk packaged with UPC

Part Number	Size (Inches)	Working Load Limit (lbs)
45943-22	1/4" - 5/16"	2,600
45943-20	5/16" - 3/8"	5,400
45943-20HD	5/16" - 3/8"	6,600
45943-21	3/8" - 1/2"	9,200
45943-23	1/2" - 5/8"	13,000



XHD™ Ratchet | Built-in Thread Safety Stops

- High visibility yellow E-coat
- Drop forged steel
- 2 Piece handle
- Welded barrel
- Retail pack 1
- Bulk packaged with UPC

Part Number	Size (Inches)	Working Load Limit (lbs)
50360-20	5/16" - 3/8"	6,600
50360-21	3/8" - 1/2"	9,200



Chain Binder Accessories

50140-10 | EZ Binder

Use with 5/16^{IN} G70 - 3/8^{IN} G43 Chain
5,400 lbs WLL (2,450 kg)

- Quick acting ratchet design is easy to tension and release
- Extra long handle with contour grip
- Heavy gauge steel construction
- Corrosion resistant electro zinc plating
- Free wheel function for quick take up
- Swiveling grab hooks for ease of use
- Will take up 12" of chain during tensioning



50117-10 | Lever Binder Lock

Lock your chain and lever in place after tightening with our Lever Binder Lock.



CARGO BARS & LOGISTIC STRAPS

Adjustable Cargo Bars

SL125 | Light Duty Ratcheting Cargo Bar

40IN - 70IN

- Powder coated & chromate weather resistant finish
- Soft grip padded ratchet handle
- Cushioned spring loaded non-slip pads (2" x 4")
- Easy glide tube design for superior ease of use
- No assembly required
- Prevents cargo from sliding and spilling over
- Fits all standard pickup trucks & SUV's



410-PU-1 | Heavy Duty Cargo Bar for Pickups & SUVs

46IN - 61IN

- 2" x 4" Pads



410-PU-2 | Heavy Duty Cargo Bar for Pickups & Vans

60IN - 72IN

- 2" x 4" Pads



43782-15 | Pro-Heavy Duty Aluminum Standard Cargo STA®

89.75IN - 104.5IN

- 4" x 4" Pads



48407-10 | Pro-Heavy Duty Galvanized Steel Economy Cargo STA®

89.75IN - 104.5IN

- 2" x 4" Pads
- Bolt-on feet



49348-11 | Bar Keep™ Cargo Bar Holder

- Fits 4" x 4" pads or 2" x 2" pads
- Holds 2 bars



CAUTION: Due to variations in the wall construction cargo bars do not have a working load limit.

Logistic Straps



Ancra logistic straps are designed to work with traditional horizontal and vertical E & A-track and assembled with spring actuated series E end fittings. Straps are made with heavy duty 6,000 lbs polyester webbing and color coded by length for easy identification. Fixed end lengths are all 48in. For other style logistic straps and end fittings, contact Customer Service at (800) 626-8353 for assistance.



Spring End Fitting

Cam Buckle | Spring End Fitting

833 lbs WLL (378 kg)

- 48" Fixed end
- Bulk packaged



Part Number	Length (Feet)	Color
40602-17	12'	Yellow
40602-18	16'	Gray
40602-19	20'	Blue

Ratchet Buckle | Spring End Fitting

1,333 lbs WLL (605 kg)

- 48" Fixed end
- Bulk packaged



Part Number	Length (Feet)	Color
48672-13	12'	Yellow
48672-14	16'	Gray
48672-15	20'	Blue

Heavy Duty

CARGO BARS & LOGISTIC STRAPS

HEAVY DUTY ACCESSORIES

Corner Protectors

X-TREME Guard® | Lightweight Corner Protectors | Made in USA

- Constructed of high density polyethylene for strength and durability
- Spreads the strap tension over the length of the guard
- More durable than wood and greater memory than aluminum
- Weather and UV resistant, good to -30°F
- Lightweight & made from recycled materials
- Sold in bundles of 10 - each piece UPC labeled



Part Number	Trade Size (Inches)
50089-12	12"
50089-24	24"
50089-36	36"
50089-48	48"



50092-10 | EZ Winder

- Quickly and easily winds straps onto winches for storage when not in use
- Carded package of 1
- Tri-lingual warning tags



43986-10 | Corner Protector Takes up to 4" Webbing

- High density plastic polymer
- Bulk packaged with UPC
- Retail pack quantity 1
- 50 Per box



Heavy Duty

HEAVY DUTY ACCESSORIES

Did you know that correct product labeling is a federal requirement on all heavy duty tie-downs?

Section 2.8.1 of the Web, Sling, and Tie Down Association's (WSTDA) Standard T-1 requires each web tie-down to be marked or labeled with the applicable Working Load Limit (WLL) as well as a manufacturer identification.

Since a 2-piece strap can be separated from itself, Ancra has adopted the standard of applying working load labels to both the fixed and adjustable ends of all our 2", 3" and 4" heavy duty straps. These labels include the required safe working load information as well as the manufacturer, in this case Ancra.

In the United States, a strap with no visible marking reverts to the weakest version of that type of tie-down. This means that 2" x 27', 3,333 lb strap could be rated by an inspector as low as 1,000 lbs, which could lead to heavy fines and possible impounding or delays in delivery.





BUNGEE CORDS & TARP TIES

Bungee Cords
& Tarp Ties

BUNGEE CORDS

Bungee Cords

95400 Series | Standard

- Vinyl coated steel hooks with tip guards
- Strong UV and abrasion resistance
- Stranded first quality latex rubber
- Bulk packaged with UPC tag
- Color coded by length



Part Number	Length (Inches)	Color
95413	13"	Green
95418	18"	Yellow
95424	24"	Blue
95430	30"	Orange
95436	36"	Red

95400 | Starter Pack - Standard

Contains (10) each of 95413, 95418, 95424, 95430, & 95436



95500 Series | EZ Grip | Bulk

- PVC molded grip steel hooks
- Stranded first quality latex rubber
- Strong UV & abrasion resistance
- Bulk packaged with UPC tag
- Color coded by length



Part Number	Length (Inches)	Color
95518	18"	Yellow
95524	24"	Blue
95536	36"	Red
95540	40"	Green
95548	48"	Orange

95500 | Starter Pack - EZ Grip Bulk

Contains (10) each of 95518, 95524, 95536, 95540, & 95548



95500-1 Series | EZ Grip | Clamshell

- PVC molded grip steel hooks
- Stranded first quality latex rubber
- Strong UV & abrasion resistance
- Clamshell packaging
- Color coded by length



Part Number	Length (Inches)	Color
95518-1	18"	Yellow
95524-1	24"	Blue
95536-1	36"	Red
95540-1	40"	Green
95548-1	48"	Orange

95500-1 | Starter Pack - EZ Grip Clamshell

Contains (6) each of 95518-1, 95524-1, 95536-1, 95540-1, & 95548-1



95600 Series | Heavy Duty

- 50% More rubber than standard cords
- HD steel hooks w/corrosion resistant coating & tip guards
- Stranded first quality latex rubber
- Safety orange polyester outer jacket, all lengths
- Bulk packaged with UPC tag



Part Number	Length (Inches)
95618	18"
95624	24"
95632	32"
95640	40"
95648	48"

95600 | Starter Pack - Heavy Duty Bulk

Contains (10) each of 95618, 95624, 95632, 95640, & 95648



SL148 | Carrabungee™ Cord

- "Build-a-Net" technology
- Link multiple cords together
- 24" Length
- Carabiner hooks
- Polyester jacket



XB210-22P | 10^{IN} Mini Cords 22 Piece

Great for bundling and storing tools, cords, blueprints, camping equipment, household items and much more!



SL33 | 10^{IN} Mini Cords 4 Piece

Great for bundling and storing tools, cords, blueprints, camping equipment, household items and much more!



BUNGEE CORDS

Bungee Nets

95480 | Bungee Net with Detachable Hooks

- Great for securing tarps and keeping light cargo and debris from moving around
- Smaller 5" x 5" cross pattern design for greater load coverage
- One size fits most trucks & SUV's
- Minimum size: 48" x 72"
- Maximum stretch: 72" x 108"
- Includes storage bag
- 16 Hooks are detachable

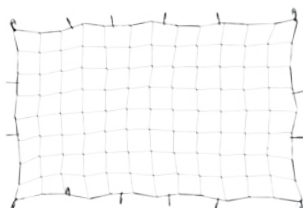

SL50 | 36" 6 Arm Bungee Net

- 6 Attachment points
- Center ring gives infinite shape options
- Great for larger, bulky items



SL56 | 15" x 30" ATV Net

- 10 Hooks
- Fits standard ATV racks
- Stores easily



Tarp & Canopy Ties

SL43 | 10 Piece

- For use with tarps and canopies
- 10 Piece
- Length: 10in



Bungee Cord - Assortments

SL69 | 6 Piece

- Heavy duty cord
- Polybagged
- Safety orange style



Contains:
(2)-24"
(2)-32"
(2)-40"

SL41 | 12 Piece

- Standard cord
- Polybagged
- Multi-colored style



Contains:
(4)-18"
(2)-24"
(1)-30"
(1)-36"
(4)-10" mini

SL64 | 18 Piece

- Standard cord
- Polybagged
- Yellow-jacket style



Contains:
(4)-16"
(4)-18"
(4)-24"
(2)-30"
(4)-10" mini

SL42 | 20 Piece

- Standard cord
- Multi-colored



Contains:
(4)-12"
(2)-18"
(2)-24"
(1)-32"
(6)-canopy
(5)- 10" mini

TARP TIES

Commercial Grade

95800 Series | EPDM Tarp Ties

- Proprietary blend of EPDM with excellent UV properties to resist cracking and extend strap life
- Strong stretch and recovery performance in both hot and cold temperatures
- ½ Inch thick, teardrop ends to help prevent hooks from tearing through strap
- Zinc plated, rust-resistant steel S-hooks
- Color coded, tri-lingual, UPC coded labels applied directly to each strap
- Bulk packaged with UPC
- Retail pack 1

Made in USA 

Part Number	Trade Size (Inches)	Length (Inches) with Hooks
95810	10"	14"
95815	15"	19"
95821	21"	24"
95831	31"	35"
95841	41"	45"



95800 | EPDM Tarp Tie Starter Pack

Contains (10) each of 95810, 95815, 95821, 95831, & 95841

Heavy Duty / Fleet Grade

52200 GL Series | GOLDLINE® EPDM Tarp Ties

- 100% EPDM
- Longer lasting
- Molded EPDM construction for high ozone resistance and strength
- Resiliency of molded natural rubber for good cold weather stretch properties



NOTE: GOLDLINE® Tarp Ties are sold by the box of 50 tarp ties. Individual straps are not UPC coded. Order quantity of 1 = 50 tarp ties conveniently packed in polybags of 10 each.

Made in USA 

Part Number	Trade Size (Inches)	Length (Inches) with Hooks
52210GL	10"	14"
52215GL	15"	19"
52221GL	21"	24"
52231GL	31"	35"
52241GL	41"	45"

SL58 | 10 Piece Assortment



Contains:
(4)-14"
(2)-19"
(2)-24"
(2)-35"

(Hook to Hook Measurement)

49454 | Rubber Rope Reel

- Solid core rubber
- 150' Coils
- Bulk non-packaged

Made in USA 

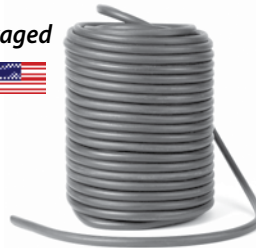

Part Number	Size (Inches)
49454-11	3/8"
49454-13	7/16"

49211-10 | Rubber Rope Hook

- Steel wire with twisted loop
- Bulk 100 per pack





SLINGS & RECOVERY STRAPS

Slings &
Recovery Straps

LIFTING SLINGS

Polyester Eye to Eye

- *Lightweight & economical*
- *Single-ply & double-ply styles*
- *WSTDA industry compliant tri-lingual warning tags*
- *Reinforced loop ends with protective wear sleeve*
- *Flat eye loops on 1" width*
- *Tapered eye loops on 2", 3", & 4" widths*
- *Shrink-wrap package*
- *Durable service inspection tag helps track usage*



All Ancra lifting slings, both eye-to-eye and round sling styles, are built to the Web Sling & Tie Down Association (WSTDA) standards which cover construction, ratings, and markings.

The standard rating for a sling is based on a straight-line pull, or vertical pull, as the WSTDA defines it. This number begins to skew as the rigging style and angle of pull changes. An instruction sheet is included with each sling and the user is responsible for making these calculations.

When the sling is looped through itself to cinch down on the lifted piece, known as a choker-style lift, the lifting capacity is de-rated roughly 20% compared to the vertical rating. This is due to the stress points caused by the sling pinching on itself.

If the lift is being done basket style, utilizing two lifting points, the effective lifting capacity is doubled compared to the vertical rating. Each point can support its original vertical rated capacity.

Per WSTDA requirements, all Ancra lifting slings have these three types of lifts and ratings on their sewn-in tag.

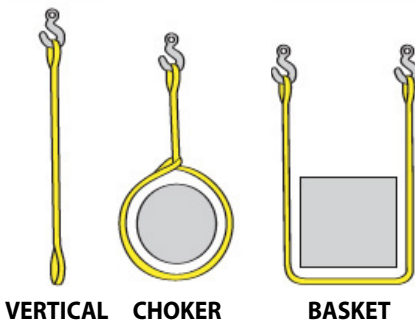

VERTICAL **CHOKER** **BASKET**

EE1 Series | Single Ply Slings

1" Width

Vertical WLL - 1,600 lbs (725 kgs)
Choker WLL - 1,250 lbs (575 kgs)
Basket WLL - 3,200 lbs (1,450 kgs)

Part Number	Length (Feet)
20-EE1-9801X3	3'
20-EE1-9801X4	4'
20-EE1-9801X6	6'
20-EE1-9801X10	10'

2" Width

Vertical WLL - 3,100 lbs (1,400 kgs)
Choker WLL - 2,450 lbs (1,125 kgs)
Basket WLL - 6,200 lbs (2,800 kgs)

Part Number	Length (Feet)
20-EE1-9802X3	3'
20-EE1-9802X4	4'
20-EE1-9802X6	6'
20-EE1-9802X10	10'
20-EE1-9802X12	12'
20-EE1-9802X14	14'

EE2 Series | Double Ply Slings

1" Width

Vertical WLL - 3,100 lbs (1,400 kgs)
Choker WLL - 2,450 lbs (2,250 kgs)
Basket WLL - 6,200 lbs (2,800 kgs)

Part Number	Length (Feet)
20-EE2-9801X4	4'
20-EE2-9801X8	8'

2" Width

Vertical WLL - 6,200 lbs (2,800 kgs)
Choker WLL - 4,950 lbs (2,250 kgs)
Basket WLL - 12,400 lbs (5,600 kgs)

Part Number	Length (Feet)
20-EE2-9802X3	3'
20-EE2-9802X4	4'
20-EE2-9802X6	6'
20-EE2-9802X8	8'
20-EE2-9802X10	10'
20-EE2-9802X12	12'
20-EE2-9802X16	16'
20-EE2-9802X20	20'
20-EE2-9802X30	30'

3" Width

Vertical WLL - 8,800 lbs (3,975 kgs)
Choker WLL - 7,000 lbs (3,175 kgs)
Basket WLL - 17,600 lbs (7,975 kgs)

Part Number	Length (Feet)
20-EE2-9803X10	10'
20-EE2-9803X12	12'
20-EE2-9803X16	16'
20-EE2-9803X20	20'

4" Width

Vertical WLL - 11,000 lbs (4,975 kgs)
Choker WLL - 8,800 lbs (3,975 kgs)
Basket WLL - 22,000 lbs (9,975 kgs)

Part Number	Length (Feet)
20-EE2-9804X6	6'
20-EE2-9804X8	8'
20-EE2-9804X10	10'
20-EE2-9804X12	12'
20-EE2-9804X16	16'
20-EE2-9804X20	20'
20-EE2-9804X30	30'

LIFTING SLINGS

Endless Round

- *Lightweight & durable*
- *Low stretch properties for optimum use in low headroom applications*
- *Continuous looped polyester load yarns inside*
- *Abrasion resistant double wall polyester protective cover*
- *Color coded to industry capacity standards*
- *WSTDA industry compliant tri-lingual warning tags*
- *Shrink-wrap package*
- *Design allows sling to be easily rotated to avoid excess stress on a single bearing point*



1^{IN} Width | Purple

Vertical WLL - 2,600 lbs (1,200 kgs)

Choker WLL - 2,100 lbs (1,000 kgs)

Basket WLL - 5,200 lbs (2,400 kgs)

Part Number	Length (Feet)
20-ENR1X3	3'
20-ENR1X4	4'
20-ENR1X6	6'
20-ENR1X8	8'
20-ENR1X12	12'



2^{IN} Width | Green

Vertical WLL - 5,300 lbs (2,400 kgs)

Choker WLL - 4,200 lbs (1,900 kgs)

Basket WLL - 10,600 lbs (4,800 kgs)

Part Number	Length (Feet)
20-ENR2X3	3'
20-ENR2X4	4'
20-ENR2X8	8'
20-ENR2X12	12'
20-ENR2X20	20'



3^{IN} Width | Yellow

Vertical WLL - 8,400 lbs (3,800 kgs)

Choker WLL - 6,700 lbs (3,000 kgs)

Basket WLL - 16,800 lbs (7,600 kgs)

Part Number	Length (Feet)
20-ENR3X3	3'
20-ENR3X4	4'
20-ENR3X8	8'
20-ENR3X12	12'
20-ENR3X20	20'



4^{IN} Width | Tan

Vertical WLL - 10,600 lbs (4,800 kgs)

Choker WLL - 8,500 lbs (3,800 kgs)

Basket WLL - 21,200 lbs (9,600 kgs)

Part Number	Length (Feet)
20-ENR4X10	10'
20-ENR4X16	16'



5^{IN} Width | Red

Vertical WLL - 13,200 lbs (6,000 kgs)

Choker WLL - 10,600 lbs (4,800 kgs)

Basket WLL - 26,400 lbs (12,000 kgs)

Part Number	Length (Feet)
20-ENR5X4	4'
20-ENR5X6	6'
20-ENR5X12	12'
20-ENR5X20	20'



7^{IN} Width | Blue

Vertical WLL - 21,200 lbs (9,600 kgs)

Choker WLL - 17,000 lbs (7,600 kgs)

Basket WLL - 42,400 lbs (19,200 kgs)

Part Number	Length (Feet)
20-ENR7X6	6'



VEHICLE RECOVERY STRAPS

Polyester Straps

800 Series | Polyester Recovery Straps

15^{FT} - 50^{FT} Length

2^{IN} - 10^{IN} Width

- Abrasion resistant
- UV resistant
- Chemical resistant
- Mildew resistant
- Stores easily using sewn in storage band
- Packed in pre-labeled bins for easy merchandising



Part Number	MVW (lbs)	Length (Feet)	Width (Inches)	Color	Case Pack	End Type
800-215H	6,000	15'	2"	Gray	5	Safety Hook
800-225H	6,000	25'	2"	Gray	5	Safety Hook
800-220	8,000	20'	2"	Gray	6	Twisted/Tapered Loop
800-230	8,000	30'	2"	Gray	6	Twisted/Tapered Loop
800-330	12,000	30'	3"	Gray	4	Twisted/Tapered Loop
800-430	16,000	30'	4"	Gray	3	Twisted/Tapered Loop
800-440	16,000	40'	4"	Blue	2	Twisted/Tapered Loop
800-450	16,000	50'	4"	Red	2	Twisted/Tapered Loop
800-630	24,000	30'	6"	Gray	2	Twisted/Tapered Loop
800-1040	62,500	40'	10"	Blue	1	Twisted/Tapered Loop

MVW (Maximum Vehicle Weight) *The maximum weight of the vehicle being recovered, including cargo load, for which the strap is intended for use.*

Straps & Ropes

SL51 | ATV Tow Rope

13^{FT} x 5/8^{IN}

3,500 lbs MVW (1,587 kg)

- Durable braided polypropylene rope
- Steel safety hooks



95194 | Recovery Rope

13^{FT} Rope w/Safety Hooks

3,500 lbs MVW (1,587 kg)

- 5/8" Rope
- Steel safety hooks
- Diamond braided polypropylene rope
- Bulk bin



SL31 | Tow Strap

15^{FT} x 2^{IN}

5,000 lbs MVW (2,268 kg)

- Polyester webbing
- Steel safety hooks



SL24 | Recovery Strap

20^{FT} x 2^{IN}

9,000 lbs MVW (4,082 kg)

- Polyester webbing
- Twisted sewn loops



900-115H | 3 Point™ Recovery Strap

15^{FT} Recovery Strap

1,000 lbs MVW (454 kg)

- Snap hooks & D-rings
- Great for snowmobiles, ATV's, and other small recreational vehicles
- Soft loop with protective sleeves guard vehicle finish
- Rugged zinc plated hardware





CARGO CONTROL ACCESSORIES

TRUCK & TRAILER HARDWARE

O-Track Hardware



XH8003-12PB | 12/Box
 12^{IN} O-Track Beveled
 1,333 lbs WLL (600 kg)
 • Great for floor mounting



XH8005-12PB | 12/Box
 Single Stud O-Track Fitting
 1,333 lbs WLL (600 kg)
 • Designed for standard
 & beveled logistic track



XH8006-12PB | 12/Box
 Double Stud O-Track Fitting
 2,000 lbs WLL (909 kg)
 • Designed for standard
 & beveled logistic track



TRUCK & TRAILER HARDWARE



EASY MERCHANDISING

All XH series hardware products are packaged in a self-merchandising display box and each piece is individually UPC tagged.

E-Track Hardware



XH8022-12PB | 12/Box
 HD E-Track Fitting with O-Ring
 2,000 lbs WLL (909 kg)
 • Makes E-track useable with standard
 tie-down hooks
 • Low profile



47772-12 | Bulk
 2^{IN} HD E-Track Fitting with O-Ring
 1,833 lbs WLL (833 kg)
 • Makes E-track useable with standard
 tie-down hooks
 • Low profile

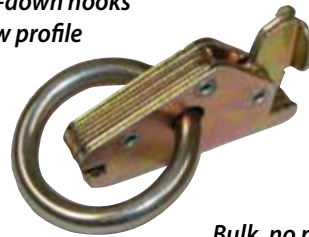

Bulk, no package

XH8016-12PB | 12/Box
 12^{IN} E-Track
 2,000 lbs WLL (909 kg)*
 • Bolt or screw to floors, sidewalls or
 wood studs
 • Painted enamel green finish
 • 12 Gauge steel



XH8023-12PB | 12/Box
 Snap-Loc™
 1,333 lbs WLL (600 kg)*
 • Bolt or screw to floors, sidewalls,
 ceilings, or wood studs
 • Single slot design
 • Electric coated black finish



XH8021-10PB | 10/Box
 7^{IN} E-Track Tie-Off Strap with
 Stamped D-Ring
 1,000 lbs WLL (454 kg)
 • 7" Extension
 • Stamped ring
 • Spring loaded E/A fitting



TRUCK & TRAILER HARDWARE

Anchor Points



XH8039-12PB | 12/Box
1" Flip Ring
 400 lbs WLL (181 kg)
 • Steel wire ring with bracket
 • Surface mount design



XH8032-12PB | 12/Box
1-1/2" HD Flip Ring
 1,666 lbs WLL (750 kg)
 • Steel wire ring with bracket
 • Surface mount design



XH8037-12PB | 12/Box
1" Flip Ring
 250 lbs WLL (113 kg)
 • 4" Oval pan surface mount design



XH8036-12PB | 12/Box
1" Flip Ring
 400 lbs WLL (181 kg)
 • 3-1/2" x 5" Oval recessed mount design



XH8033-12PB | 12/Box
1-1/2" Flip Ring
 1,666 lbs WLL (750 kg)
 • 4-7/16" Square pan recessed mount design



XH8034-8PB | 8/Box
3" Flip Ring
 1,666 lbs WLL (750 kg)
 • 6" Round pan recessed
 • 360 degree rotation



XH8031-8PB | 8/Box
5/8" D-Ring
 5,000 lbs WLL (2,267 kg)
 • Forged steel ring with bracket
 • Surface mount weld-on design



XH8030-8PB | 8/Box
3/4" D-Ring
 6,666 lbs WLL (3,023 kg)
 • Forged steel ring with bracket
 • Surface mount weld-on design



Logistic Track



*NOTE: Working load limit will vary depending upon installation of track. Track is designed to work in combination with recommended tie-downs and fittings. Please reference TTMA RP No. 47-99 for installation. Attach track using screws, rivets or by welding. Contact vehicle manufacturer or qualified installer to determine fastener size and mounting method. Welding of galvanized material may emit toxic fumes. Please use caution and proper ventilation.

48117-21-60.00 | Bulk
5FT Horizontal E-Track
 • Bolt or screw to floors, sidewalls or wood studs
 • Galvanized
 • 12 Gauge steel



48117-25-60.00 | Bulk
5FT Horizontal E-Track
 • Bolt or screw to floors, sidewalls or wood studs
 • Gray powder coat finish
 • 12 Gauge steel



40467-33-72.00 | Bulk
6FT HD Logistic Track
 • Aluminum



50193-30-72.00 | Bulk
6FT Beveled HD Logistic Track
 • Aluminum



NETS & BLANKETS

Utility Pad

SL215 | Multi-Use Utility Pad | Camo

60^{IN} x 62^{IN}

- Heavy duty colorfast poly/cotton blend with continuous quilted stitching for added durability
- One piece UV treated and metal filtered filler
- Machine washable
- Great for moving & storage, garage floors, camping, beach, hunting, vehicle protection, & more



Disclaimer: Do NOT use for bedding

Nets

50199 | Adjustable Pickup Truck Cargo Nets

60^{IN} x 62^{IN}

1,200 lbs WLL (540 kg)

- Intended for securement of cargo being transported in the cargo bed of a standard pickup truck
- Proper use will insure compliance with FMCSA and Canada's National Safety Code Standard 10 against loss of cargo
- Place net over the cargo and secure at four corners of the net using the quick straps with safety hooks provided
- Secure side rings with 2 additional straps

Part Number	Size (Inches)	Bed Type
50199-10	72" x 80"	Short
50199-11	72" x 96"	Long



50199-10



50199-11

D-rings and connectors are spaced to accommodate various heights of loads. Each net comes with six (6), 1-1/4" x 5' long straps with a die cast cam buckle. Each strap has vinyl coated S-hooks with wire keepers to prevent them from disengaging.
Net Openings: 6.0"



10869 | Adjustable Cargo Nets for A or E-Track

2,500 lbs WLL (1,134 kg)

- Spring lever E-clips
- Quick release cam buckles
- Creates a barrier between loads to help prevent load shift and falling cargo
- Actual working load capacity dependent upon track installation (Please reference TIMA RP No. 47-99 or hire a professional installer)
- Openings on sides of net will vary from interior net openings based on trailer width

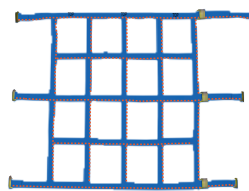

10869-10

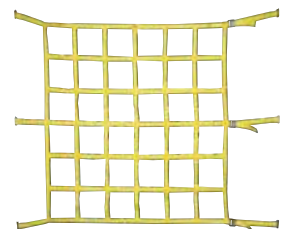

10869-20

Part Number	Width (Inches)	Height (Inches)	Opening (Inches)	Color
10869-10	60" - 72"	46"	9" x 10"	Blue
10869-20	84" - 96"	72"	9" x 10"	Yellow





SAFETY PRODUCTS

SAFETY PRODUCTS

Wearables

50435-L | Size L
50435-XL | Size XL

Reflective Work Gloves

- Split leather palm and fingers
- Breathable high visibility cloth back
- Retro-reflective stripes



50532-12 | Yellow Green
Reflective Vests

- High visibility fluorescent mesh
- Contrasting retro-reflective stripes on front and back
- One size fits most
- hook and loop fastener at front & elastic side straps
- Compliant to CAN/CSA Z96-15 Class 2 & ANSA/ISEA 107-2004 Class 2



50532-13 | Orange Red
Reflective Vests

- Fluorescent mesh
- Contrasting retro-reflective stripes on front and back
- One size fits most
- hook and loop fastener at front & elastic side straps
- Compliant to CAN/CSA Z96-15 Class 2 & ANSA/ISEA 107-2004 Class 2



Toss 'N Tie™

50409-10 | TOSS 'N TIE™
Tie-Down Placement Tool

Don't throw your tie-downs; use TOSS 'N TIE™ to get them over the load!

EASY TO USE

- 1) Unroll cord and attach to a cargo strap or cargo chain
- 2) Toss TOSS 'N TIE™ ball up and over load
- 3) Go to other side, grab cord and pull your tie-down into place



Part Number	Pack Number	Package Type
50409-10-BULK	1	Bulk
50409-10-1PACK	1	Clamshell
50409-10-4PACK	4	Clamshell

Lights & Reflectors

50440-10 | H.E.L.P. Light
3 Puck Light Kit with Bag

- Made with impact resistant plastic
- 15 High output LEDs (12 red, 3 white)
- Rain proof
- Back contains magnet and folding hook
- Three lighting modes:

- Red LEDs on steady (Road Flare)
- Red LEDs double pulse (Emergency Strobe)
- White LEDs on steady (Flashlight)



50437-10PK-SP | LED Flashlight

- 400 Lumens
- Light range 200M
- Blue on-off tactical type tail switch
- Anodized aluminum case
- Adjustable beam size
- 10 Piece shelf pack



50434-10 | Triangle Warning Kit
3 Collapsible Reflective Triangles

- Comes with durable red plastic case
- Certified by AMECA
- In compliance with FMCSA standards
- DOT certified









FLAGS & BANNERS

Flags

<p>49893-10 Fluorescent Red 18" x 18" • Heavy duty mesh • Wooden dowel</p> 	<p>49893-11 Red 18" x 18" • Cotton • Steel wire rod</p> 	<p>49893-12 Fluorescent Red 18" x 18" • Heavy duty mesh • 2 Brass grommets</p> 
<p>49893-13 Fluorescent Orange 18" x 18" • Heavy duty mesh • Wooden dowel</p> 	<p>49893-14 Fluorescent Orange 18" x 18" • Heavy duty mesh • 2 Brass grommets</p> 	<p>50430-10 Magnetic Flag Holder • 2.3" Diameter • Ceramic magnet • Center screw & wing nut for attachment</p> 

Banners

<p>49894-12 2-Sided 14" x 72" • Wide Load/Oversize Load • Yellow vinyl • Grommets & 44" ropes</p> 	<p>49894-10 2-Sided 18" x 84" • Wide Load/Oversize Load • Yellow vinyl • Grommets & 44" ropes</p> 	<p>49894-11 2-Sided 18" x 84" • Wide Load/Oversize Load • Yellow vinyl • Sewn-in ropes</p> 
<p>49894-13 Single Sided 18" x 84" • Oversize Load • Yellow polyester mesh • Grommets & 44" ropes</p> <p>MESH CONSTRUCTION</p> 	<p>49894-14 Single Sided 18" x 84" • Wide Load • Yellow polyester mesh • Grommets & 44" ropes</p> <p>MESH CONSTRUCTION</p> 	<p>49894-15 2-Sided 18" x 84" • Wide Load/Oversize Load • Yellow vinyl • Sewn-in bungee cords</p> 
<p>49895-10 Canada "D" 12" x 96" • Canada 'D' • Vinyl • 10 Grommets</p> 		<p>All Flags and Banners meet FMCSA 393.87 Standards</p>

GLOSSARY

Abrasion	The mechanical wearing of a surface from contact with another object.
Aggregate Working Load Limit	The summation of the Working Load Limit (WLL) of all tie-downs used to secure an article of cargo.
Anchor Point	The location to which a tie-down is attached to a vehicle or article of cargo. If the anchor point is inadequate to support the force of the tie-down system, then the load rating of the tie-down will be limited to the strength of the anchor point.
Breaking Strength	The tensile load in pounds or kilograms at which any part of the securement assembly fails.
Cargo	All articles or material carried by a vehicle, including those used in operation of the vehicle.
Design Factor	The ratio of the breaking strength to the Working Load Limit (WLL).
Direct Tie-Down	A tie-down that is attached directly to the cargo.
Elongation	The measurement of stretch at a specifically applied load, expressed as a percentage of the original length.
Fabrication Efficiency	The synthetic web tie-down assembly break strength, as a percentage of the webbing strength prior to fabrication.
Indirect Tie-Down	A tie-down which passes over the cargo and is secured to the vehicle at both ends. Tension in the tie-down increases the pressure of an article or stack of articles on the deck of the vehicle.
Keeper	A device used on a hook to prevent the hook from inadvertently releasing.
Length	The distance between extreme end bearing points of the synthetic web tie-down assembly, including the fittings.
Lever Load Binder	A chain binder incorporating an overcenter locking action.
Maximum Vehicle Weight (MVW)	The maximum weight of the vehicle being recovered, including cargo load, for which the strap is intended for use.
Planogram	A diagram or model that indicates the placement of retail products on shelves in order to maximize sales.
Proof Load Test	A non-destructive load test to some multiple of the working load limit.
Selvage	The woven or knitted edge of synthetic webbing.
Sew/Stitch Pattern	The pattern of the stitches used to sew the webbing together.
Shoring Bar	A structural bar placed transversely between the walls of a vehicle to prevent cargo from tipping or shifting.
Ultimate Test	A load test of a securement assembly tested to failure.
Warp	A longitudinal load bearing yarn in webbing.
Winch	A device for tensioning a webbing or wire rope tie-down that is fitted with means to lock the initial tension.
Working Load Limit (WLL)	The maximum load a component or assembly should be subjected to during routine use.

INDEX

10869-10	Net	38	20-ENR7X6	Sling, Endless	33	43795-90-40	Winch Strap, 4"	20	47640-31	Winch, Lashing	21
10869-20	Net	38	214-30KP	Winch Strap	20	43795-95-30	Winch Strap, 4"	20	47772-12	E-Track Fitting	36
10936-06	Tie-Down, Contractor Grade	13	30AS21-BK	Axle Strap	17	43986-10	Corner Protector	26	47934-11	Wheel Dolly Strap	16
10936-12	Tie-Down, Contractor Grade	13	30AS21-BL	Axle Strap	17	45143-20	Wheel Dolly Strap	16	47935-11	Wheel Dolly Strap	16
10936-16	Tie-Down, Contractor Grade	13	30AS21-RD	Axle Strap	17	45214-10	Soft-Hook	15	48117-21-60.00	Track	37
10936-20	Tie-Down, Contractor Grade	13	30AS33-BK	Axle Strap	17	45214-12	Soft-Hook	15	48117-25-60.00	Track	37
20-EE1-9801X3	Sling, Eye to Eye	32	30AS33-BL	Axle Strap	17	45214-13	Soft-Hook	15	48407-10	Cargo Bar	25
20-EE1-9801X4	Sling, Eye to Eye	32	30AS33-RD	Axle Strap	17	45214-25	Soft-Hook	15	48487-24	Auto Tie-Down	17
20-EE1-9801X6	Sling, Eye to Eye	32	30ATB	Tire Bonnet	16	45214-26	Soft-Hook	15	48672-13	Logistics Strap	25
20-EE1-9801X10	Sling, Eye to Eye	32	30ATB-MS-BK	Tire Bonnet	16	45880-10	Transport Chain	23	48672-14	Logistics Strap	25
20-EE1-9802X3	Sling, Eye to Eye	32	30ATB-MS-YL	Tire Bonnet	16	45880-11	Transport Chain	23	48672-15	Logistics Strap	25
20-EE1-9802X4	Sling, Eye to Eye	32	30ATB-MS-BL	Tire Bonnet	16	45880-12	Transport Chain	23	48987-20	Tie-Down, Heavy Duty	9
20-EE1-9802X6	Sling, Eye to Eye	32	30ATB-MS-GR	Tire Bonnet	16	45880-13	Transport Chain	23	48987-21	Tie-Down, Heavy Duty	9
20-EE1-9802X10	Sling, Eye to Eye	32	30ATB-MS-RD	Tire Bonnet	16	45881-10-16	Transport Chain	22	48987-24	Tie-Down, Heavy Duty	9
20-EE1-9802X12	Sling, Eye to Eye	32	30ATB-MS-OR	Tire Bonnet	16	45881-10-16-SP	Transport Chain	22	48987-25	Tie-Down, Heavy Duty	9
20-EE1-9802X14	Sling, Eye to Eye	32	30RT-BK	Tire Bonnet	16	45881-10-20	Transport Chain	22	48987-28	Tie-Down, Heavy Duty	9
20-EE2-9801X4	Sling, Eye to Eye	32	30RT-YL	Tire Bonnet	16	45881-10-20-SP	Transport Chain	22	48987-29	Tie-Down, Heavy Duty	9
20-EE2-9801X8	Sling, Eye to Eye	32	30RT-RD	Tire Bonnet	16	45881-10-25	Transport Chain	22	48987-90-27	Tie-Down, Heavy Duty	9
20-EE2-9802X3	Sling, Eye to Eye	32	30RT-OR	Tire Bonnet	16	45881-10-25-SP	Transport Chain	22	48987-90-30	Tie-Down, Heavy Duty	9
20-EE2-9802X4	Sling, Eye to Eye	32	30RT-BL	Tire Bonnet	16	45881-11-16	Transport Chain	22	48987-92-27	Tie-Down, Heavy Duty	9
20-EE2-9802X6	Sling, Eye to Eye	32	30TB	Tire Bonnet	16	45881-11-16-SP	Transport Chain	22	48987-92-30	Tie-Down, Heavy Duty	9
20-EE2-9802X8	Sling, Eye to Eye	32	30TB-MS	Tire Bonnet	16	45881-11-20	Transport Chain	22	49023-20	Auto Tie-Down	17
20-EE2-9802X10	Sling, Eye to Eye	32	40467-33-72.00	Track	37	45881-11-20-SP	Transport Chain	22	49023-21	Auto Tie-Down	17
20-EE2-9802X12	Sling, Eye to Eye	32	40602-17	Logistic Strap	25	45881-11-25	Transport Chain	22	49023-22	Auto Tie-Down	17
20-EE2-9802X16	Sling, Eye to Eye	32	40602-18	Logistic Strap	25	45881-11-25-SP	Transport Chain	22	49207-137	Winch	21
20-EE2-9802X20	Sling, Eye to Eye	32	40602-19	Logistic Strap	25	45881-13-20	Transport Chain	22	49211-10	Rubber Rope Hook	30
20-EE2-9802X30	Sling, Eye to Eye	32	40888-10	Tie-Down, Motorsports	14	45881-13-25	Transport Chain	22	49288-10	Hardware	15
20-EE2-9803X10	Sling, Eye to Eye	32	40888-26	Tie-Down, Motorsports	14	45943-10	Chain Binder	24	49346-10	Tie-Down, Heavy Duty	9
20-EE2-9803X12	Sling, Eye to Eye	32	40888-34	Tie-Down, Motorsports	14	45943-10HD	Chain Binder	24	49346-11	Tie-Down, Heavy Duty	9
20-EE2-9803X16	Sling, Eye to Eye	32	410-PU-1	Cargo Bar	25	45943-11	Chain Binder	24	49346-12	Tie-Down, Heavy Duty	9
20-EE2-9803X20	Sling, Eye to Eye	32	410-PU-2	Cargo Bar	25	45943-12	Chain Binder	24	49346-13	Tie-Down, Heavy Duty	9
20-EE2-9804X6	Sling, Eye to Eye	32	41659-10-27	Winch Strap, 2"	20	45943-13	Chain Binder	24	49346-14	Tie-Down, Heavy Duty	9
20-EE2-9804X8	Sling, Eye to Eye	32	41659-10-30	Winch Strap, 2"	20	45943-14	Chain Binder	24	49346-15	Tie-Down, Heavy Duty	9
20-EE2-9804X10	Sling, Eye to Eye	32	41659-11-30	Winch Strap, 2"	20	45943-20	Chain Binder	24	49346-90-27	Tie-Down, Heavy Duty	9
20-EE2-9804X12	Sling, Eye to Eye	32	41659-13-27	Winch Strap, 2"	20	45943-20HD	Chain Binder	24	49346-90-30	Tie-Down, Heavy Duty	9
20-EE2-9804X16	Sling, Eye to Eye	32	41659-13-30	Winch Strap, 2"	20	45943-21	Chain Binder	24	49346-91-27	Tie-Down, Heavy Duty	9
20-EE2-9804X20	Sling, Eye to Eye	32	41660-10-30	Winch Strap, 3"	20	45943-22	Chain Binder	24	49346-91-30	Tie-Down, Heavy Duty	9
20-EE2-9804X30	Sling, Eye to Eye	32	41660-14-30	Winch Strap, 3"	20	45943-23	Chain Binder	24	49346-93-27	Tie-Down, Heavy Duty	9
20-ENR1X3	Sling, Endless	33	42313-10	Winch Bar	21	45946-10	Hook, Clevis	23	49346-93-30	Tie-Down, Heavy Duty	9
20-ENR1X4	Sling, Endless	33	42313-12	Winch Bar	21	45946-11	Hook, Clevis	23	49348-11	Cargo Bar Holder	25
20-ENR1X6	Sling, Endless	33	42313-17	Winch Bar	21	45946-12	Hook, Clevis	23	49380-10	Tie-Down, Motorsports	14
20-ENR1X8	Sling, Endless	33	42313-19	Winch Bar	21	45946-13	Hook, Clevis	23	49380-11	Tie-Down, Motorsports	14
20-ENR1X12	Sling, Endless	33	43563-10	Winch	21	45982-11	Tie-Down, Heavy Duty	9	49380-12	Tie-Down, Motorsports	14
20-ENR2X3	Sling, Endless	33	43564-147	Winch	21	45982-15	Tie-Down, Heavy Duty	9	49454-11	Rubber Rope Reel	30
20-ENR2X4	Sling, Endless	33	43564-167	Winch	21	45982-19	Tie-Down, Heavy Duty	9	49454-13	Rubber Rope Reel	30
20-ENR2X8	Sling, Endless	33	43565-127	Winch	21	45982-34	Tie-Down, Heavy Duty	9	49494-212	Tie-Down, Motorsports	14
20-ENR2X12	Sling, Endless	33	43573-10	Winch	21	45982-36	Tie-Down, Heavy Duty	9	49498-10	Tie-Down, Motorsports	15
20-ENR2X20	Sling, Endless	33	43579-20	Winch	21	45982-43	Tie-Down, Heavy Duty	9	49498-11	Tie-Down, Motorsports	15
20-ENR3X3	Sling, Endless	33	43782-15	Cargo Bar	25	45982-90-27	Tie-Down, Heavy Duty	9	49498-12	Tie-Down, Motorsports	15
20-ENR3X4	Sling, Endless	33	43795-10-27	Winch Strap, 4"	20	45982-90-30	Tie-Down, Heavy Duty	9	49603-10	Wheel Chock	15
20-ENR3X8	Sling, Endless	33	43795-10-30	Winch Strap, 4"	20	45982-95-27	Tie-Down, Heavy Duty	9	49716-10	Winch	21
20-ENR3X12	Sling, Endless	33	43795-10-40	Winch Strap, 4"	20	45982-95-30	Tie-Down, Heavy Duty	9	49716-11	Winch	21
20-ENR3X20	Sling, Endless	33	43795-10-50	Winch Strap, 4"	20	47295-10	Tie-Down, Motorsports	14	49723-10	Winch Cap	21
20-ENR4X10	Sling, Endless	33	43795-10-60	Winch Strap, 4"	20	47295-11	Tie-Down, Motorsports	14	49893-10	Flag	41
20-ENR4X16	Sling, Endless	33	43795-11-30	Winch Strap, 4"	20	47295-12	Tie-Down, Motorsports	14	49893-11	Flag	41
20-ENR5X4	Sling, Endless	33	43795-13-30	Winch Strap, 4"	20	47295-14	Tie-Down, Motorsports	14	49893-12	Flag	41
20-ENR5X6	Sling, Endless	33	43795-14-30	Winch Strap, 4"	20	47295-16	Tie-Down, Motorsports	14	49893-13	Flag	41
20-ENR5X12	Sling, Endless	33	43795-15-30	Winch Strap, 4"	20	47439-10	Tie-Down, Motorsports	15	49893-14	Flag	41
20-ENR5X20	Sling, Endless	33	43795-90-30	Winch Strap, 4"	20	47439-11	Tie-Down, Motorsports	15	49894-10	Banner	41

INDEX

49894-11	Banner	41	50435-L	Work Gloves	40	95418	Bungee Cord, Standard	28	SL16	Tie-Down, Consumer	10
49894-12	Banner	41	50435-XL	Work Gloves	40	95424	Bungee Cord, Standard	28	SL18	Tie-Down, Consumer	10
49894-13	Banner	41	50437-10PK-SP	Flashlight	40	95430	Bungee Cord, Standard	28	SL24	Recovery Strap	34
49894-14	Banner	41	50440-10	HELP Lights	40	95436	Bungee Cord, Standard	28	SL27	Tie-Down, Consumer	10
49894-15	Banner	41	50529-11-10-BX	Transport Chain	22	95480	Bungee Net	29	SL30	Tie-Down, Consumer	10
49895-10	Banner	41	50532-12	Safety Vest	40	95500	Bungee Cord, EZ Grip	28	SL31	Recovery Strap	34
49958-38-20	Transport Chain	22	50532-13	Safety Vest	40	95500-1	Bungee Cord, EZ Grip	28	SL32	Tie-Down, Consumer	10
49958-38-20-SP	Transport Chain	22	52210GL	Tarp Tie, Goldline	30	95518	Bungee Cord, EZ Grip	28	SL33	Bungee Cord, Mini	28
49970-102	Tie-Down, Motorsports	15	52215GL	Tarp Tie, Goldline	30	95518-1	Bungee Cord, EZ Grip	28	SL38	Tie-Down, Consumer	10
50013-31	Shackle	23	52221GL	Tarp Tie, Goldline	30	95524	Bungee Cord, EZ Grip	28	SL41	Bungee Assortment	29
50013-38	Shackle	23	52231GL	Tarp Tie, Goldline	30	95524-1	Bungee Cord, EZ Grip	28	SL42	Bungee Assortment	29
50013-44	Shackle	23	52241GL	Tarp Tie, Goldline	30	95536	Bungee Cord, EZ Grip	28	SL43	Canopy Tie	29
50013-50	Shackle	23	556	Tie-Down, Heavy Duty	9	95536-1	Bungee Cord, EZ Grip	28	SL46	Tie-Down, Consumer	10
50013-63	Shackle	23	556-WHK	Tie-Down, Heavy Duty	9	95540	Bungee Cord, EZ Grip	28	SL47	Tie-Down, Consumer	10
50013-75	Shackle	23	557-15	Tie-Down, Heavy Duty	9	95540-1	Bungee Cord, EZ Grip	28	SL48	Tie-Down, Consumer	10
50013-88	Shackle	23	557-15WHK	Tie-Down, Heavy Duty	9	95548	Bungee Cord, EZ Grip	28	SL50	Bungee Net	29
50015-10	Winch Bar	21	557	Tie-Down, Heavy Duty	9	95548-1	Bungee Cord, EZ Grip	28	SL51	Recovery Rope	34
50015-20	Winch Bar	21	557-WHK	Tie-Down, Heavy Duty	9	95600	Bungee Cord, Heavy Duty	28	SL56	Bungee Net	29
50015-21	Winch Bar	21	557-40	Tie-Down, Heavy Duty	9	95618	Bungee Cord, Heavy Duty	28	SL58	Tarp Tie Assortment	30
50016-25	Quick Link	23	557-40WHK	Tie-Down, Heavy Duty	9	95624	Bungee Cord, Heavy Duty	28	SL64	Bungee Assortment	29
50016-31	Quick Link	23	557-50	Tie-Down, Heavy Duty	9	95632	Bungee Cord, Heavy Duty	28	SL66	Tie-Down, Consumer	10
50016-38	Quick Link	23	557-50WHK	Tie-Down, Heavy Duty	9	95640	Bungee Cord, Heavy Duty	28	SL69	Bungee Assortment	29
50019-10	Hook, Slip	23	557-60	Tie-Down, Heavy Duty	9	95648	Bungee Cord, Heavy Duty	28	SL81	Tie-Down, Consumer	11
50019-11	Hook, Slip	23	557-60WHK	Tie-Down, Heavy Duty	9	95800	Tarp Tie Assortment	30	SL91	Tie-Down, Consumer	10
50019-12	Hook, Slip	23	800-215H	Recovery Strap	34	95810	Tarp Tie	30	SL100	Tie-Down, Consumer	11
50019-13	Hook, Slip	23	800-225H	Recovery Strap	34	95815	Tarp Tie	30	SL101	Tie-Down, Consumer	11
50019-20	Hook, Slip	23	800-220	Recovery Strap	34	95821	Tarp Tie	30	SL102	Tie-Down, Consumer	11
50019-21	Hook, Slip	23	800-230	Recovery Strap	34	95831	Tarp Tie	30	SL125	Cargo Bar	25
50019-22	Hook, Slip	23	800-330	Recovery Strap	34	95841	Tarp Tie	30	SL148	Carabungee	28
50019-23	Hook, Slip	23	800-430	Recovery Strap	34	96011	Tent Strap, 1"	18	SL215	Utility Pad	38
50025-08	Chain Binder	24	800-440	Recovery Strap	34	96012	Tent Strap, 1"	18	XB210-22P	Bungee Cord, Mini	28
50025-09	Chain Binder	24	800-450	Recovery Strap	34	96013	Tent Strap, 1"	18	XC012-1P	Tie-Down, Commercial	12
50025-10	Chain Binder	24	800-630	Recovery Strap	34	96014	Tent Strap, 1"	18	XC108-2P	Tie-Down, Commercial	12
50089-12	Corner Protector	26	800-1040	Recovery Strap	34	96021	Tent Strap, 2"	18	XH8003-12PB	Track	36
50089-24	Corner Protector	26	900-115H	Recovery Strap, 3-Point	34	96022	Tent Strap, 2"	18	XH8005-12PB	Fitting	36
50089-36	Corner Protector	26	95180	Tie-Down, Bulk Bin	11	96023	Tent Strap, 2"	18	XH8006-12PB	Fitting	36
50089-48	Corner Protector	26	95181	Tie-Down, Bulk Bin	11	96024	Tent Strap, 2"	18	XH8016-12PB	Track	36
50092-10	Web Winder	26	95182	Tie-Down, Bulk Bin	11	96031	Tent Strap, 2"	18	XH8021-10PB	Fitting	36
500-C6-RD	Auto Tie-Down	17	95183	Tie-Down, Bulk Bin	11	96032	Tent Strap, 2"	18	XH8022-12PB	Fitting	36
500-C8-BK	Auto Tie-Down	17	95184	Tie-Down, Bulk Bin	11	96041	Tent Strap, Cam	18	XH8023-12PB	Hardware	36
500-C8-BL	Auto Tie-Down	17	95185	Tie-Down, Bulk Bin	11	96061	Canopy Tie, White	18	XH8030-8PB	D-Ring	37
500-C8-RD	Auto Tie-Down	17	95186	Tie-Down, Bulk Bin	11	96062	Canopy Tie, White	18	XH8031-8PB	D-Ring	37
500-C10-BK	Auto Tie-Down	17	95187	Tie-Down, Bulk Bin	11	96100	Rope Puller	5	XH8032-12PB	Flip Ring	37
500-RAS-BK	Auto Tie-Down	17	95188	Tie-Down, Bulk Bin	11	96101	Web Puller	5	XH8033-12PB	Flip Ring	37
50117-10	Binder Lock	24	95189	Tie-Down, Bulk Bin	11	96111	Cable Puller	4	XH8034-8PB	Flip Ring	37
50140-10	Chain Binder	24	95190	Tie-Down, Bulk Bin	11	96112	Cable Puller	4	XH8036-12PB	Flip Ring	37
50193-30-72.00	Track	37	95191	Tie-Down, Bulk Bin	11	96114	Cable Puller	4	XH8037-12PB	Flip Ring	37
50199-10	Net	38	95192	Tie-Down, Bulk Bin	11	96121	Cable Puller	4	XH8039-12PB	Flip Ring,	37
50199-11	Net	38	95193	Tie-Down, Bulk Bin	11	96122	Cable Puller	4	XH8088-2P	Stake Pocket Anchor	11
50360-20	Chain Binder	24	95194	Tie-Down, Bulk Bin	11, 34	96140	Fence Pliers	5	XR015-1P	Tie-Down, Commercial	12
50360-21	Chain Binder	24	95370	Tie-Down, Retractable	13	96142	Fence Pliers	5	XR015-4P	Tie-Down, Commercial	12
50364-38-10	Transport Chain	22	95371	Tie-Down, Retractable	13	96146	Bin Wheel	5	XR015-C1P	Tie-Down, Commercial	12
50364-38-20	Transport Chain	22	95372	Tie-Down, Retractable	13	96147	Wire Grip	5	XR108-2P	Tie-Down, Commercial	12
50378-10-10	Transport Chain	22	95380	Tie-Down, Retractable	13	96148	Wire Stretcher, Woven	5	XR115-C2P	Tie-Down, Commercial	12
50409-10-1PK	Toss 'N Tie	40	95381	Tie-Down, Retractable	13	96149	Wire Stretcher, Fence	5			
50409-10-4PK	Toss 'N Tie	40	95382	Tie-Down, Retractable	13	APS-15192	Tie-Down, Commercial	13			
50409-10-bulk	Toss 'N Tie	40	95391	Tie-Down, Retractable	11, 13	APS-3	Tie-Down, Contractor Grade	13			
50430-10	Flag Holder	41	95400	Bungee Cord, Standard	28	SL01	Tie-Down, Consumer	10			
50434-10	Triangle Warning Kit	40	95413	Bungee Cord, Standard	28	SL05	Tie-Down, Consumer	10			



DESIGNER AND MANUFACTURER OF CARGO RESTRAINT SYSTEMS

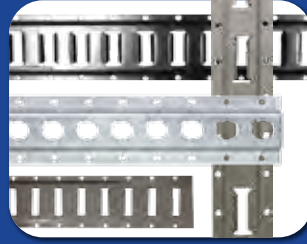

Web Winches

Ancra winches comply with DOT, WSTDA-T3 and Canadian Standard 905 regulations. Available in different base configurations to suit a variety of needs and load requirements.

All winches shown below are right hand models. Left hand models may be available on special orders. All winches shown below are bottom mount unless otherwise specified.

Black powder coat is the standard finish for all winches.

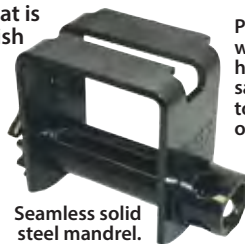

Seamless solid steel mandrel.

Powder coating withstands 250 hours of standard salt spray testing to ensure years of service.

Stamped working load limit and Ancra name certify quality.



43563-10
Standard Weld-On
Weight: 8.6 lbs./3.9 kg.
WLL: 5,500 lbs./2,500 kg.



43573-10
Storable Weld-On
Weight: 9.1 lbs./4.1 kg.
WLL: 5,500 lbs./2,500 kg.



43564-12
Standard Storable Portable w/ 2SS
Weight: 11.1 lbs./5. kg.
WLL: 5,500 lbs./2,500 kg.



43564-147
Standard Portable w/ 2SS Lighter 7mm heat treated frame
Weight: 7.7 lbs./3.5 kg.
WLL: 5,500 lbs./2,500 kg.



43579-20
Low Profile Side Mount Weld-On
Weight: 7.3 lbs./3.3 kg.
WLL: 5,500 lbs./2,500 kg.



43565-157
Standard C Track Slider Lighter 7mm heat treated frame
Weight: 7.6 lbs./3.5 kg.
WLL: 6,000 lbs./2,730 kg.



43565-127
Storable C Track Slider Lighter 7mm heat treated frame
Weight: 8.2 lbs./3.7 kg.
WLL: 6,000 lbs./2,730 kg.



49207-137
Standard Double L Track Slider Lighter 7mm heat treated frame
Weight: 6.5 lbs./2.9 kg.
WLL: 5,500 lbs./2,500 kg.



49207-187
Low Profile Double L Track Slider Lighter 7mm heat treated frame
Weight: 6.2 lbs./2.8 kg.
WLL: 5,500 lbs./2,500 kg.

Special Application Winches

Web Winches



48101-103
3-Bar Low Profile Side Mount Weld-On
Weight: 9.5 lbs./4.3 kg.
WLL: 6,000 lbs./2,730 kg.



49706-10
Standard Slider Wilson Track
Weight: 12.5 lbs./5.7 kg.
WLL: 5,500 lbs./2,500 kg.



49246-10-BP
Standard Slider Utility Trailer Track
Weight: 13 lbs./5.9 kg.
WLL: 5,500 lbs./2,500 kg.

Combo Winch



41681-10
Standard Combination Weld-On
Weight: 10.6 lbs./4.8 kg.
WLL: 5,500 lbs./2,500 kg.

SilverCap OverDrive Ratcheting Cap

PATENTED

Convert any winch into a ratcheting winch by adding Ancra's OverDrive Ratcheting Cap. The lubricated cap with a Grime Guard Weather-Tight Seal fits over the existing winch cap without having to remove the winch from the trailer, making it faster than conventional winches.



49723-10
Weight: 3.45 lbs./1.56 kg.



SilverCap OverDrive
Turns Any Winch Into A Ratcheting Winch





Winch Track

For standard C track and Double L track slider winches

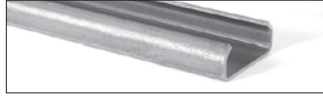

42357-11
Steel C Track - Formed from high strength 1/4" steel plate
 Weight: 39 lbs./17.73 kg.
 Length: 6'

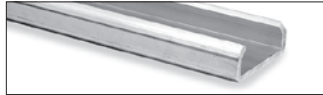

42357-21
Aluminum C Track - High strength aluminum extrusion
 Weight: 19 lbs./8.64 kg.
 Length: 6'

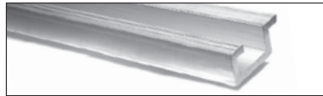

49242-10-120
Aluminum Double L Track - Designed for Double L slider winches. Weight: 26.25 lbs./11.92 kg. Length: 10'

PortaWinch

Versatile solution to turn stake pockets into anchoring points on flatbed trailers

PORTAWINCH™ (3-Bar Style) **PATENTED**

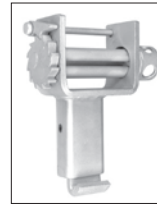

49716-10
 Standard outward off-set
 Weight: 11.5 lbs./5.2 kg.
 WLL: 5,500 lbs./2,500 kg.

49716-11
 Inward off-set for track-mounted tarp clearance.
 Weight: 11.5 lbs./5.2 kg.
 WLL: 5,500 lbs./2,500 kg.

Covered by multiple U.S. and International Patents.

Ergo 360 Winch Bars

Easily rotates to any angle to provide the leverage needed to tension a strap



The Ergo 360 Bar is simply a better alternative to standard winch bars. The ergonomic design keeps the handle and tip in parallel alignment and in your "Power Zone" making it safer and easier to use. Available in 3 models standard, combination, and combination box end.



50015-10
Standard Ergo Bar, 34", Painted, Weight: 5.0 lbs./2.27 kg.



50015-20
Combination Ergo Bar, 34", Painted, Weight: 6.5 lbs./2.95 kg.



50015-21
Combination Box End Ergo Bar, 38-5/8", Painted, Weight: 6.0 lbs./2.72 kg.

Winch Bars

Tapered and angled at the end for easy operation, Ankra's winch bar handles are knurled at two sections, and the mushroom tip helps keep the bar from slipping from the winch cap. They are heat-treated for extra strength and cycle tested to simulate years of heavy use. Combination winch bars can be used to release tension on chain binders. Use caution to avoid injury. Not to be used as a cheater bar.



Flanged mushroom tip helps keep the bar from slipping from the winch cap.



42313-10
Standard Painted, Weight: 5.0 lbs./2.27 kg.



42313-12
Combination Box End, Painted Silver and Yellow, Weight: 6.5 lbs./2.95 kg.



42313-19
Combination Chrome, Weight: 6.5 lbs./2.95 kg.



42313-17
Standard Chrome, Weight: 5.0 lbs./2.27 kg.



Standard 2" Winch Strap WLL: 3,333 lbs./1,515 kg.



41659-10-27
27-ft. with Flat Hook

41659-10-30
30-ft. with Flat Hook



41659-13-27
27-ft. with Wire Hook

41659-13-30
30-ft. with Wire Hook

Standard 3" Winch Strap WLL: 5,400 lbs./2,450 kg.



41660-10-27
27-ft. with Flat Hook

41660-10-30
30-ft. with Flat Hook



41660-14-27
27-ft. with Chain Anchor

41660-14-30
30-ft. with Chain Anchor

Standard 4" Winch Strap WLL: 5,400 lbs./2,450 kg.



43795-10-27
27-ft. with Flat Hook

43795-10-30
30-ft. with Flat Hook



43795-11-27
27-ft. with Delta Ring

43795-11-30
30-ft. with Delta Ring



43795-13-30
30-ft. with Twisted Loop



43795-15-27
27-ft. with Chain Anchor

43795-15-30
30-ft. with Chain Anchor

Premium 4" X-TREME Winch Strap WLL: 5,400 lbs./2,450 kg.

Delivers greater abrasion resistance over conventional web straps

The ultimate winch straps for extreme applications. Ancra's new X-TREME webbing delivers greater durability, strength and abrasion resistance. Testing shows 80% retained strength over standard webbing.



43795-91-30
30-ft. with Delta Ring



43795-90-27
27-ft. with Flat Hook

43795-90-30
30-ft. with Flat Hook



43795-95-30
30-ft. with Chain Anchor



Roll-On/Roll-Off Container Strap 4" x 5-ft. with Container Hook-FMCSA Compliant



49526-10

4-in. x 5-ft. Strap w/ 48968-11 Container Hook.
WLL: 5,400 lbs./2,450 kg.



49526-11

4-in. x 5-ft. Strap w/ 48968-11 Container Hook and Sewn Loop end.
WLL: 5,400 lbs./2,450 kg.

Coil Racks Available in both light duty and heavy duty models for your specific applications



49344-10

Light Duty, 10 gauge steel, Weight: 5.7 lbs./2.60 kg.



49344-12

Heavy Duty, 1/4 steel sheet per ASTM A36, Weight: 15.63 lbs./7.09 kg.

Transport Chain

Grade 70 Transport Chain meets NACM standards

Chain Assemblies with Clevis Hooks



5/16" Chain Assemblies

45881-10-16 5/16" x 16" WLL: 4,700 lbs.

45881-10-20 5/16" x 20" WLL: 4,700 lbs.

45881-10-25 5/16" x 25" WLL: 4,700 lbs.

3/8" Chain Assemblies

45881-11-16 3/8" x 16" WLL: 6,600 lbs.

45881-11-20 3/8" x 20" WLL: 6,600 lbs.

45881-11-25 3/8" x 25" WLL: 6,600 lbs.

1/2" Chain Assemblies

45881-13-20 1/2" x 20" WLL: 11,300 lbs.

45881-13-25 1/2" x 25" WLL: 11,300 lbs.

Bulk Chain Clevis Hooks



5/16" Chain x 400'

45880-10 Wt: 408 lbs.

3/8" Chain x 200'

45880-11 Wt: 296 lbs.

1/2" Chain x 100'

45880-13 Wt: 251 lbs.

1/4" Chain x 400'

45880-12 Wt: 262 lbs.

5/16" Clevis Hook

45946-10 Wt: .85 lbs.

3/8" Clevis Hook

45946-11 Wt: 1.10 lbs.

1/2" Clevis Hook

45946-13 Wt: 2.10 lbs.

1/4" Clevis Hook

45946-12 Wt: .40 lbs.

Load Binders Drop forged steel meeting FMCSA and DOT specifications. In three popular models.

Lever Load Binders



45943-10

Accepts 5/16"-3/8" Chain
WLL: 5,400 lbs. Wt. 7.9 lbs.

45943-10HD HEAVY DUTY

Accepts 5/16"-3/8" Grade 70 Chain
WLL: 6,600 lbs. Wt. 9.4 lbs.

45943-11

Accepts 3/8"-1/2" Chain
WLL: 9,200 lbs. Wt. 11.9 lbs.

45943-13

Accepts 1/2"-5/8" Chain
WLL: 13,000 lbs. Wt. 20.8 lbs.

45943-12

Accepts 1/4"-5/16" Chain
WLL: 2,600 lbs. Wt. 3.5 lbs.

Recoilless Lever Load Binder



45943-14

Accepts 5/16"-3/8" Chain
WLL: 5,400 lbs. Wt. 9.0 lbs.

Lever Binder Locking Clip



50117-10

Securely Holds Binder Handle
Weight: .40 lbs./0.18 kg.

Ratchet Load Binders



45943-20

Accepts 5/16"-3/8" Chain
WLL: 5,400 lbs. Wt. 10.4 lbs.

45943-20HD HEAVY DUTY

Accepts 5/16"-3/8" Grade 70 Chain
WLL: 6,600 lbs. Wt. 10.5 lbs.

45943-21

Accepts 3/8"-1/2" Chain
WLL: 9,200 lbs. Wt. 11.8 lbs.

45943-23

Accepts 1/2"-5/8" Chain
WLL: 13,000 lbs. Wt. 15.7 lbs.

45943-22

Accepts 1/4"-5/16" Chain
WLL: 2,600 lbs. Wt. 3.57 lbs.



Ratchet Strap Assemblies Meets DOT and WSTDA T-1 standards for synthetic web tiedowns 2" Long-Wide Handle Ratchet Buckle Straps WLL: 3,333 lbs./1,515 kg.



45982-10
27 ft. with Flat Hooks

45982-11
30 ft. with Flat Hooks



45982-15
27 ft. with Chain Anchor

45982-34
30 ft. with Chain Anchor



45982-42
27 ft. with Wire Hooks

45982-43
30 ft. with Wire Hooks



45982-19
27 ft. with Twisted Snap Hooks

45982-36
30 ft. with Twisted Snap Hooks

3" Ratchet Buckle Straps WLL: 5,400 lbs./2,450 kg.



48987-20
27 ft. with Flat Hooks

48987-21
30 ft. with Flat Hooks



48987-24
27 ft. with Chain Anchor

48987-25
30 ft. with Chain Anchor

4" Ratchet Buckle Straps WLL: 5,400 lbs./2,450 kg.



49346-10
27 ft. with Flat Hooks

49346-11
30 ft. with Flat Hooks



49346-14
27 ft. with Chain Anchor

49346-15
30 ft. with Chain Anchor

Corner Protectors Full line of corner protectors to protect your straps and cargo



42098-11
Fiber Reinforced Rubber - For use with up to 3" web straps
Weight: .63 lb./ .29 kg.



42098-12
Fiber Reinforced Rubber - For use with up to 4" web straps
Weight: .75 lb./ .34 kg.



49584-10
12" Plastic - For use with up to 4" web straps
Weight: .47 lb./ .21 kg.



49377-10
Steel - For use with chain
Weight: 1.10 lbs./ .50 kg.



49577-10
Steel - For use with chain
Weight: .90 lb./ .41 kg.



49756-10
Steel - For use with chain and straps
Weight: 1.26 lbs./ .57 kg.



49377-11
Rubber Coated Steel
For use with chain and extends 4" to protect load.
Weight: 1.9 lbs./ .86 kg.



41516-11
Aluminum 6061-T6
Suitable for 2" webbing.
Weight: .63 lbs./ .29 kg.



43986-10
High Density Polymer - For up to 4" web straps
Weight: .06 lb./ .03 kg.

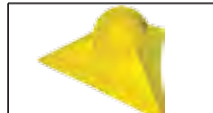

49913-10
Tarp Protector
Yellow plastic.
Weight: .21 lb./ .09 kg.

BE SURE YOU'RE SECURED If any part of the load securement system is loose — even if the required number of straps are used per regulation but are not tensioned properly — the load is considered unsecured. It is your responsibility to ensure the cargo is secure.



Ancra X-TREME - Engineered for Strength And Durability

Ancra Ratchet Buckle Strap Assemblies have redefined the industry standard. Now with the tested and proven 80% retained strength of Ancra X-TREME webbing and the integrity of our ratchet buckles, these assemblies surpass the others. A complete line of Ancra's standard and heavy-duty assemblies and accessories can meet all your specific requirements.

- Custom lengths and a wide range of end hardware are available
- Complies with WSTDA T-1 Standards
- Webbing meets or exceeds WSTDA T-4 Standards
- Standard fixed end length is 18-in., unless otherwise specified



Premium 2" X-TREME Ratchet Straps WLL: 3,333 lbs./1,515 kg.

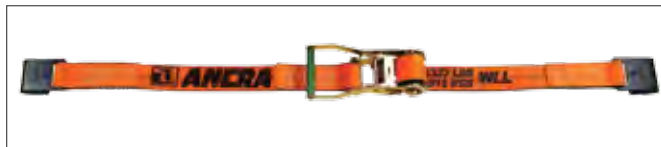

45982-90-27
27 ft. with Flat Hooks



45982-90-30
30 ft. with Flat Hooks

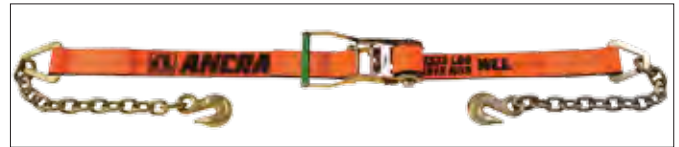

45982-93-30
30 ft. with Chain Anchors

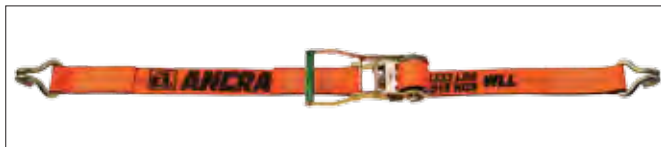

45982-95-27
27 ft. with Wire Hooks



45982-95-30
30 ft. with Wire Hooks

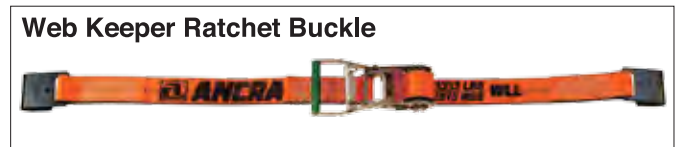

45982-90-27-WK
27 ft. Web Keeper with Flat Hooks



45982-90-30-WK
30 ft. Web Keeper with Flat Hooks

Premium 3" X-TREME Ratchet Straps WLL: 5,400 lbs./2,450 kg.

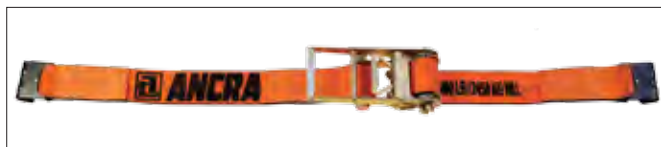

48987-90-27
27 ft. with Flat Hooks



48987-90-30
30 ft. with Flat Hook

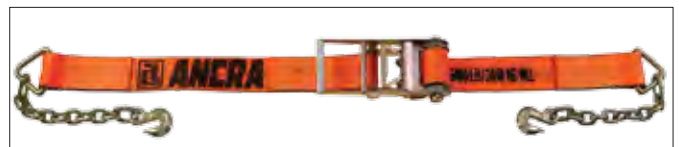

48987-92-27
27 ft. with Chain Anchors



48987-92-30
30 ft. with Chain Anchors

Premium 4" X-TREME Ratchet Straps WLL: 5,400 lbs./2,450 kg.



49346-90-27
27 ft. with Flat Hooks



49346-90-30
30 ft. with Flat Hooks



49346-91-27
27 ft. with Chain Anchors



49346-91-30
30 ft. with Chain Anchors



49346-93-27
27 ft. with Wire Hooks



49346-93-30
30 ft. with Wire Hooks

Top Premium Brand Tarp Ties

Made in the USA and known for quality, durability, and resistance to the elements, these tarp ties offer good stretch recovery and maintain their strength over the entire life of the tarp ties. The two lines include the longest lasting, larger cross section Goldline® Heavy Duty EPDM tarp ties best recognized by truckers, and the standard cross section Silverline Elite® EPDM. Our natural rubber tarp ties are best suited for colder climates and are our most economical offering. Ancra's tarp tie offering provides you the customer with product options that can be chosen and suited to your application.



- Quantity 50 per box
- Designed to hold tarp covers on trucks and trailers
- Not to be used to restrain or secure cargo
- Wear safety glasses and use caution when using tarp ties
- Molded EPDM construction for high Ozone resistance and strength resiliency or molded natural rubber for good cold weather stretch properties

**Truckers Choice
for Over 40 Years!**

GOLDLINE®
Made in USA

SILVERLINE®
ELITE
EPDM
Made in USA

**NATURAL
RUBBER**

- 52210GL**
10" Goldline HD EPDM
- 52215GL**
15" Goldline HD EPDM
- 52221GL**
21" Goldline HD EPDM
- 52231GL**
31" Goldline HD EPDM
- 52241GL**
41" Goldline HD EPDM

- 52210SE**
10" Silverline Elite EPDM
- 52215SE**
15" Silverline Elite EPDM
- 52221SE**
21" Silverline Elite EPDM
- 52231SE**
31" Silverline Elite EPDM
- 52241SE**
41" Silverline Elite EPDM

- 52210C**
10" Natural Rubber
- 52215C**
15" Natural Rubber
- 52221C**
21" Natural Rubber
- 52231C**
31" Natural Rubber
- 52241C**
41" Natural Rubber

X-TREME GUARD™

Ancra's new high-density polyethylene X-TREME GUARD™ Corner Protector distributes strap tension over the length of the guard to prevent your cargo from being crushed by the straps and protects your webbing from cuts and abrasion. Made in lengths of 12-, 24-, 36- and 48-inches, this durable guard is strong yet lightweight, and crack/ weather resistant to -30°.

- Constructed of High Density Polyethylene for strength and durability
- Protect cargo from being crushed by the straps and the webbing from cuts and abrasion
- Spread the strap tension over the length of the guard
- More durable than wood and greater memory than aluminum
- Weather and UV resistant, Good to -30°F
- Made from recycled materials



50089-12
8" x 1' long
Weight: .8 lbs./ .36 kg.



50089-24
8" x 2' long
Weight: 1.7 lbs./ .78 kg.



50089-36
8" x 3' long
Weight: 2.7 lbs./ 1.23 kg.



50089-48
8" x 4' long
Weight: 3.6 lbs./ 1.63 kg.



Flags & Banners Meets FMCSA 393.87 Standards



49894-10

Wide Load/Oversize Load, 2-sided,
84" x 18" Vinyl
Yellow with four 44" ropes & grommets

49894-12

Wide Load/Oversize Load, 2-sided,
72" x 14" Vinyl
Yellow with four 44" ropes & grommets



49894-11

Wide Load/Oversize Load, 2-sided,
84" x 18" Vinyl
Yellow with four grommets, Sewn in Ropes,
Top and Bottom



49894-13

Oversize Load Mesh Sign, Single Sided
84" x 18" Polyester
Yellow with 4 grommets and four 44" ropes

49894-14

Wide Load Mesh Sign, Single Sided
84" x 18" Polyester
Yellow with 4 grommets and four 44" ropes



49895-10

Canadian "D" Sign
96" x 12"
Red/White Vinyl
10 Grommets



49893-10

Flourescent Red Safety Flag
18" x 18"
Heavy Duty Mesh
Wooden dowel



49893-11

Red Safety Flag
18" x 18"
Cotton
Steel wire rod



49893-12 49893-14

Flourescent Red (-12) or Orange (-14)
Safety Flag
18" x 18"
Heavy Duty Mesh
2 brass grommets

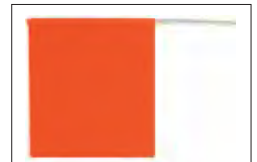

49893-13

Flourescent Orange
Safety Flag
18" x 18"
Heavy Duty Mesh
Wooden dowel

Web Winders Rolls all your winch straps neatly and quickly. Helps to extend the life of your winch straps.



50092-10

EZ Winder Strap Winder quickly and easily
winds webbing onto your winch for storage.



50391-10

Premium Cargo Strap Winder
Constructed of zinc-plated steel for maximum durability,
the new Strap Winder quickly assists in winding winch
straps into rolls for storage. Designed to clip into trailer
stake pocket or side rail.
Weight: 2.7 lb./1.2 kg.





Lift-A-Deck

THE DECK SYSTEM SPECIALISTS

Decking System

PATENTED

U.S. Patent No. 6,074,143

The most popular patented solution for decking loads in trailer and van bodies. With Ancra's patented adjustable second deck in your trailer, you can carry double the amount of palletized freight, or you can mix loads with only part of the vehicle double decked. The Ancra Lift-A-Deck® II system is the most versatile you can install. With many track styles to choose from, installations can be made on any type of vehicle construction.



Standard & Low Profile Beams w/ Low Profile Foot and Channel Assembly



49414-15

Standard LAD Beam
Adjustment range: 95.1" - 105.6"
Weight: 18.1 lbs./8.2 kg.
Decking WLL: 2,200 lbs./999 kg.
Shoring WLL: 2,200 lbs./999 kg.

49414-19

Heavy Duty LAD Beam
Adjustment range: 95.1" - 105.6"
Weight: 19.7 lbs./8.9 kg.
Decking WLL: 3,000 lbs./1,360 kg.
Shoring WLL: 2,500 lbs./1,135 kg.

Wide Top Beam w/ Low Profile Foot and Channel Assembly

The textured Beam top surface is 4-1/2" wide to increase the contact area for cargo on the beam deck.



50080-11

Wide Top LAD Beam Assembly
Adjustment range 95.1" - 105.6" / Weight: 24.9 lbs./11.3 kg.
Decking WLL: 4,000 lbs./1,816 kg. Not recommended for shoring.

PATENTED



Poly Deck Board

- Lighter than plywood - Increase trailer capacity
- Ergonomic - Convenient hand slot
- Stackable - Nests for storage
- Durable - Reduces purchase frequency
- Recyclable - Energy savings



50105-11

For beams set at 16" & 24" centers.
48" x 48" x 2.7"H / Weight: 21 lbs./9.53 kg.

Lift-A-Deck II Track Options - Other Track Styles Available



50072-14-72.00

Flanged Double Track
Beveled, Weight: 6.8 lbs./ 3.1 kg.



50058-18-72.00

Flanged Single Track
Beveled, Weight: 4.2 lbs./ 1.9 kg.

Beam Release Bar

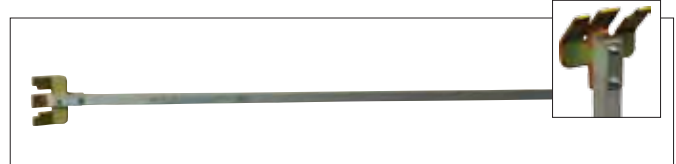

49445-12

Length: 52 inches. Weight: 2.5 lbs./1.14 kg.

Lift-A-Deck II Logistic Straps



12-ft. 16-ft. 20-ft.
40602-100 40602-101 40602-102
6,000 lb. Polyester Webbing with
Cam Buckle and Single Stud Fitting.
Working Load Limit: 833 lbs./378 kg.



12-ft. 16-ft. 20-ft.
48672-16 48672-17 48672-18
6,000 lb. Polyester Webbing with Ratchet
Buckle and Double Stud Fitting. Fixed End: 48-in.
Working Load Limit: 1,500 lbs./680 kg.

Beam Release Bar Holder



50055-10

Weight: .44 lbs./ .2 kg.



Logistic Track

Ankra Series E, A and F Track were designed to team with Ankra end fittings, Beam Sockets, and Decking/Shoring Beams for the strongest, most reliable support. Steel constructed and tested for strength, Ankra Track comes in 10 ft. (3 m) lengths for a wide range of cargo restraint applications. To withstand corrosion, Ankra galvanized track has a G-90 hot dip finish with a surface chemical treatment.

Series E Logistic Track - Made with high grade 12-gauge steel



48117-25-120.00

Gray Powdercoat

Weight: 16.6 lbs./7.5 kg.
Length: 10 ft./3 m.

48117-25-60.00

Gray Powdercoat

Weight: 8.3 lbs./3.77 kg.
Length: 5 ft./1.5 m.



48117-21-120.00

Galvanized

Weight: 17.2 lbs./7.80 kg.
Length: 10 ft./3 m.

48117-21-60.00

Galvanized

Weight: 8.6 lbs./3.90 kg.
Length: 5-ft./1.5 m.



48117-32-120.00

Black Powdercoat

Weight: 16.6 lbs./7.5 kg., Length: 10 ft./3 m.

Vertical

40838-10

Gray Powdercoat

Weight: 13.5 lbs./6.1 kg.
Length: 10 ft./3 m.

40838-11

Galvanized

Weight: 14 lbs./6.4 kg.
Length: 10 ft./3 m.

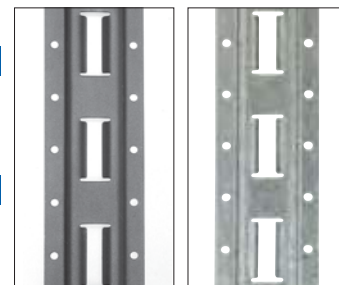

Series F Logistic Track

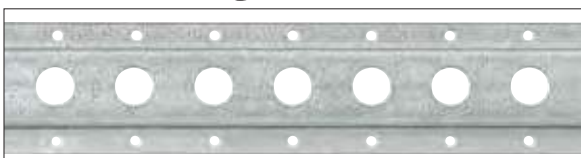

40849-14

Galvanized 1.62 in. hole spacing & 3/4" hole dia.
Weight: 6.0 lbs./2.7 kg., Length: 10 ft./3 m. 15-gauge.



49313-13

Galvanized 1.62 in. hole spacing.
Weight: 12.2 lbs./5.53 kg., Length: 10 ft./3 m. 12-gauge.

Series A Logistic Track



42948-10

Gray Powdercoat

Weight: 15.0 lbs./6.8 kg., Length: 10 ft./3 m. 12-gauge.



49359-10

Aluminum

Weight: 8 lbs./3.6 kg., Length: 10 ft./3 m.

Shoring Bars – F Series with new easy push button design

Round Shoring Bar



Square Shoring Bar



Adjustable in 2 in. increments with recommended install length of 81-117 in.



49439-10

For 3/4-in. hole diameter track (U.S.)
Shoring WLL: 500 lbs./227 kg., Wt: 20.0 lbs./9.1 kg.

49439-11

For 1-in. hole diameter track (Canada)
Shoring WLL: 500 lbs./227 kg., Wt: 20.0 lbs./9.1 kg.



49439-20

For 3/4-in. hole diameter track (U.S.)
Shoring WLL: 1,000 lbs./454 kg., Wt: 28.0 lbs./12.71 kg.

49439-21

For 1-in. hole diameter track (Canada)
Shoring WLL: 1,000 lbs./454 kg., Wt: 28.0 lbs./12.71 kg.



Series E and A Decking/Shoring Beams with Patented Flat Latch

PATENTED U.S. Patent No. 6,895,867

All Ankra Decking/Shoring Beams are equipped with our patented Flat Latch. The Flat Latch eliminates bent triggers, jammed beams, costly beam replacement and repairs, and out-of-service problems. The Flat Latch can't damage interior trailer walls. The flat latch channel assembly can be purchased separately to retro-fit older trigger style beams.



Flat Latch

Standard Duty Aluminum E and A Decking Beams - Decking & Shoring WLL: 2,200 lbs.

43638-50 Adjustment range 85.7-96.6 in. Wt: 16.0 lbs./7.3 kg.

43638-51 Adjustment range 92.9-103.8 in. Wt: 18.8 lbs./8.5 kg.

Heavy Duty Aluminum E and A Decking Beams - Decking WLL: 3,000 lbs. Shoring WLL: 2,500 lbs.

49039-50 Adjustment range 84.7-95.6 in. Wt: 20.5 lbs./9.3 kg.

49039-51 Adjustment range 92.9-103.8 in. Wt: 22.5 lbs./10.2 kg.

49039-52 Adjustment range 93.8-106.9 in. Wt: 24.25 lbs./11.0 kg.

Cargo Sta Load Bars - Available in Aluminum and Steel Bar models for light to medium duty applications. Bolt-On Feet



Aluminum Cargo Sta

43782-15 6061 T6 Aluminum, Length/Weight: 89.75 - 104.5 in. 8.95 lbs./4.07 kg. Long Tube Diameter: 1.50 in.

Steel Cargo Sta

48407-10 Galvanized Steel Tubing, Length/Weight: 89.75 - 104.5 in. 11.72 lbs./5.33 kg. Long Tube Diameter: 1.50 in.

Jack Bars - Ankra's jack mechanism makes quick work of securing loads and is available in three models for light to medium duty applications.



Heavy Duty One-Piece - Galvanized finish for corrosion resistance.

49205-25 Weight: 16.2 lbs./7.35 kg. Adjustment range: 85.0" - 104.0" Black Handle

49205-26 Weight: 16.6 lbs./7.54 kg. Adjustment range: 85.0" - 114.0" Red Handle

Heavy-Duty One-Piece Jack Bar with Hoops -

Built-in hoops for restraining small items and packages. One-Piece Galvanized

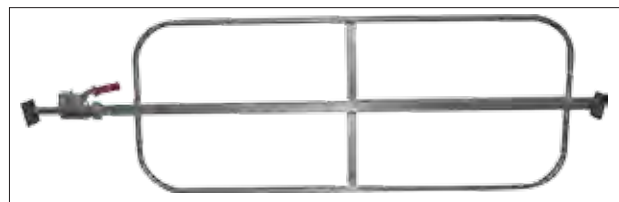

49205-27

Weight: 20.0 lbs./9.08 kg. Adjustment range: 85.0" - 114.0" Red Handle

49205-28

Weight: 19.6 lbs./9.0 kg. Adjustment range: 85.0" - 104.0" Black Handle

Universal Jack Bar - This jack bar features a patented design which allows for 3 adjustment range settings, increasing its versatility for use in half load applications.



Patented Safety Snap Pin



49205-31 Adjustment range- Fully extended: 85-114-in. Mid extension: 70-99-in. Fully retracted: 51-80-in.

Weight: 18.2 lbs./8.26 kg. **PATENTED** U.S. Patent No. 6,736,371.



Accessories

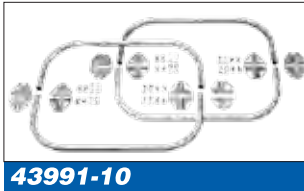

43991-10

Cargo Sta Hoop Set

Designed to help restrain the movement of small packages of cargo within your truck or trailer. For 43782 and 48407 round tube bars. Tube Diameter: 1.5 in. Weight: 10.0 lbs./4.5 kg.



49348-11

Bar Keep Cargo Bar Holder

Constructed of high quality steel and finished with black powder coating for corrosion resistance. Holds two standard or heavy-duty cargo bars. Weight: 6.68 lbs./3.03 kg.



40921-10

Standard Beam Socket

For use w/ commercial grade Douglas Fir 2"x6" lumber. Weight: .70 lb./32 kg.



40921-11

Heavy-Duty Beam Socket

For use w/ commercial grade Douglas Fir 2"x6" lumber. Internally welded plate for added strength. Weight: .85 lb./39 kg.

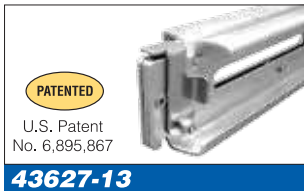

43627-13

Replacement Channel Assembly

With patented flat latch. 11 Gauge. For aluminum beams 43638, 49039 and 50158. Weight: 3.8 lbs./1.73 kg.



40386-11

Series E/A Rope Tie Off

With spring actuated fitting for rope use in Series E or A track WLL: 1,333lbs./605 kg. Weight: .40 lbs./18 kg.

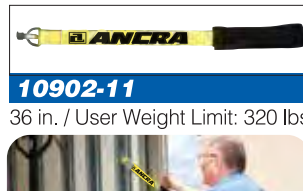

10902-11

36 in. / User Weight Limit: 320 lbs.



Driver Assist Strap

Helping Hand. Ancra's Driver Assist Strap lends a hand to drivers and dock workers climbing into and out of trailers. The 36" strap with reinforced handle connects to existing E or A track, offering a convenient additional hand grip for a more secure entry and exit. Assembled with high strength components for a rated user weight limit of 320 lbs. Patent pending.

Series E Cam Buckle Straps with Spring End Fittings

Popular straps for securing light to medium loads. Comes in 3 color coded sizes. **WLL: 833 lbs./378 kg.**



40602-17

12 ft, - Yellow Webbing. Weight: 1.65 lbs.



40602-18

16 ft, - Gray Webbing. Weight: 1.80 lbs.



40602-19

20 ft, - Blue Webbing. Weight: 1.95 lbs.

Series E Ratchet Buckle Straps with Spring End Fittings

Low profile ratchet buckle makes tensioning more convenient for securing loads. Three standard color coded sizes. **WLL: 1,333 lbs./605 kg.**



48672-13

12 ft, - Yellow Webbing. Weight: 2.25 lbs.



48672-14

16 ft, - Gray Webbing. Weight: 2.40 lbs.



48672-15

20 ft, - Blue Webbing. Weight: 2.55 lbs.

Torque Limiting Ratchet Straps with Spring End Fittings

Reduces the possibility of damage to logistics track and sidewalls by limiting the pre-load torque placed on the strap assembly. Patented ratchet mechanism limits strap tension to 300 lbs., enough to secure your load, but not enough to cause damage from over tightening. **WLL: 1,333 lbs./605 kg**



48672-33

12 ft, - Yellow Webbing. Weight: 2.50 lbs.



48672-34

16 ft, - Gray Webbing. Weight: 2.65 lbs.



48672-35

20 ft, - Blue Webbing. Weight: 2.80 lbs.



Utility Tiedowns – Versatile and reliable for securing a wide range of light- to medium-duty cargo.

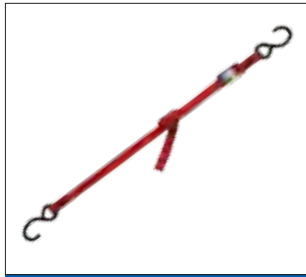

41048-10
Cam Buckle Tiedown
1" x 5-1/2' Red
Vinyl Coated S Hooks
Fixed End: 6 in.
WLL: 400 lbs./181 kg.
Weight: 1.60 lbs./.73 kg.



43887-10
Mini Ratchet Strap with D-Ring and Wire Hooks
WLL: 1,000 lbs./454 kg.
1" x 16'
Weight: 1.56 lbs./.71 kg.
43887-11 1" x 20'
Weight: 1.69 lbs./.77 kg.



49368-10
Ratcheting Tiedowns
1" x 15' 4-pack
1" red Ratchet strap with vinyl-coated S Hooks secures cargo, equipment and household furnishings.
Weight: 4.7 lbs./2.14 kg.
WLL: 266 lbs./121 kg.



49368-11
Cam Buckle Tiedowns
1" x 6' 4-pack
1" black Cam strap with scratch-resistant vinyl-coated S Hooks. A simple way to secure your possessions.
Weight: 3.7 lbs./1.69 kg.
WLL: 266 lbs./121 kg.



49368-12
Combo 4 Pack
Contains two each 1" multipurpose Ratchet and Cam Buckle tie downs with scratch-resistant vinyl coating.
Weight: 4.2 lbs./1.91 kg.
WLL: 266 lbs./121 kg.



95002
Ratcheting Tiedowns
1" x 10' 2-pack
1" black Ratchet straps with vinyl-coated S Hooks in an interactive package.
Weight: 2.25 lbs./1.0 kg.
WLL: 550 lbs./250 kg.



95007
Ratcheting Tiedowns
1" x 12' Endless Loop, 2-pack, 1" Ratchet straps in an interactive package.
Weight: 1.75 lbs./.79 kg.
WLL: 550 lbs./250 kg.



95003
Retractable Ratcheting Tiedowns
1" x 6' 2-pack
1" black Retractable Ratchet straps with scratch-resistant vinyl-coated S Hooks in an interactive package.
Weight: 3.20 lbs./1.45 kg.
WLL: 500 lbs./227 kg.



95004
Cam Buckle Tiedowns
1" x 8' 4-pack
1" red Cam straps with scratch resistant vinyl-coated S Hooks in an interactive package.
Weight: 3.8 lbs./1.72 kg.
WLL: 400 lbs./180 kg.



95005
Ratcheting Tiedowns
1" x 10' 4-pack
1" black Ratchet straps with vinyl-coated S Hooks in an interactive package.
Weight: 4.6 lbs./2.1 kg.
WLL: 550 lbs./250 kg.



49603-10
TrackStar Motorcycle Wheelchock
Quick Connect to aircraft style L track. Fits tire widths from 3.5" to 5.5". Comes complete with mounting kit.
Weight: 7.0 lbs./3.18 kg.



Specifications

Working Load Limit (WLL)

The maximum load a component or assembly should be subjected to during routine use.

Rated Load Capacity

Ratings are generally established and/or regulated by industry or legislative standards and may vary from industry to industry. The working load limit rating (WLL) is established by Federal DOT Standards at 1/3 of the Breaking Strength of the assembly.

Note: All strengths referenced in this brochure unless noted, are based on a straight pull application.

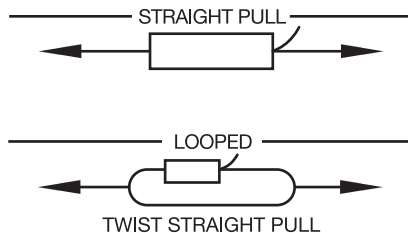

IMPORTANT NOTE:

It is the owner's and user's responsibility to determine suitability of a product for any particular use. Check all applicable industry, trade association, federal, state and local regulations. Read all operating instructions and warnings carefully.

All ratings shown in this catalog are based on the product being new, and used in normal environmental conditions. Special consideration must be given to item selection when unusual conditions can be expected. Particular caution should be exercised to avoid exposing the product to sharp edges, acids, alkalis and temperatures above 194°F.

Products are subjected to age, wear, and deterioration, all of which cause a reduction in the product's working load limit. We recommend that all products be regularly inspected. Any worn, deformed, misused or overloaded products should be replaced.

CAUTION! The component with the lowest working load capacity in the entire restraint system will determine its strength. Each component of the entire system plays an important part in restraining cargo. It is important that tie downs be attached to anchorage that are of sufficient strength to properly secure the load. For example, if one anchors a standard web binder assembly with a rated WLL of 5,000 lbs. to a device with a WLL of 1,000 lbs., then that system is only as good as the anchorage and would be limited to a 1,000 lbs. capacity WLL.

The purpose of this catalog is to assist our customers in the selection of cargo restraint products suitable for their specific applications. Because we continuously strive to offer new and improved products, part numbers and specifications are subject to change without notice. Please contact your Ancra Representative or our Customer Service Department for any new information.

Lift-@-Deck

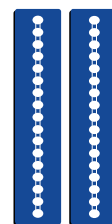

THE DECK SYSTEM SPECIALISTS

TM



NORTH AMERICA'S LARGEST DESIGNER & MANUFACTURER
OF LOAD MAXIMIZING SYSTEMS



ANCRA
INTERNATIONAL

3 STEP PROCESS

TO INCREASE PROFITS FOR YOUR FLEET

1

Evaluation

Work with customer service professionals to determine the best Lift-A-Deck II system for your fleet's application.

2

Testing

Ancra will assist in collecting and analyzing data, the test data collected will specifically show how you benefit from utilizing Lift-A-Deck II.

3

Training

A comprehensive training video will ensure properly trained loading professionals utilizing Lift-A-Deck II.

Key Training Benefits

Helps ensure all employees are trained to use the Lift-A-Deck II system properly.

Better training ensures the fleet owner is gaining maximum loading efficiencies.

THE DECK SYSTEM SPECIALISTS

& FEATURES BENEFITS



Ankra Poly Deckboard
P/N: 50105-11

*Over 20% Lighter than typical plywood
100% Recyclable Material*



LOAD FREIGHT EASILY & SECURELY WITH LIFT-A-DECK II

- + Easily Operated by a Single Person
- + Deck at Multiple Heights
- + Deck System Stores at the Ceiling
- + Low Profile Trigger Assembly
- + Maximize Profits
- + Increase Load Average
- + Reduced Damage Claims by Avoiding Double Stacking of Freight

THE DECK SYSTEM SPECIALISTS

NARROW ALUMINUM PROFILE

AIRCRAFT STYLE CARGO TRACK CREATES A SECOND DECK FOR PALLETIZED FREIGHT.



THOUSANDS OF
**SYSTEMS
IN USE**

FITS MOST TRAILERS



Available for 96- or
102-inch trailer widths
Height can be specified

CONVENIENT

New shorter foot slide is designed for inspecting both locking lugs while installed in the trailer.

LOW PROFILE TRIGGER ASSEMBLY

Large surface area of foot assembly on the system track enables the beam to take abuse from Forklifts without binding in the track.



THE DECK SYSTEM SPECIALISTS

CONFIGURATIONS

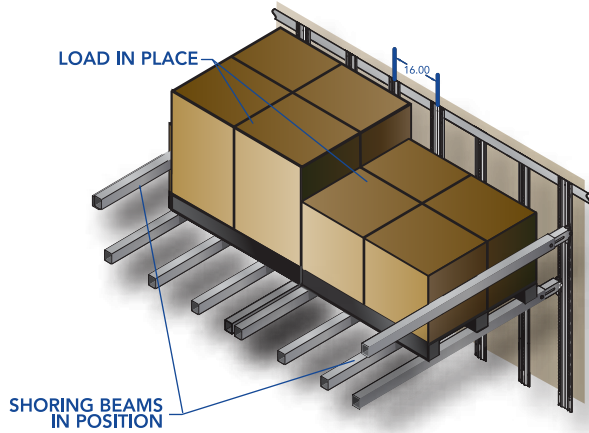

SINGLE & DOUBLE SYSTEM ON 16-IN. CENTERS
(DOUBLE-SINGLE-SINGLE-DOUBLE)
 + Pallets rest on 4 individual beams

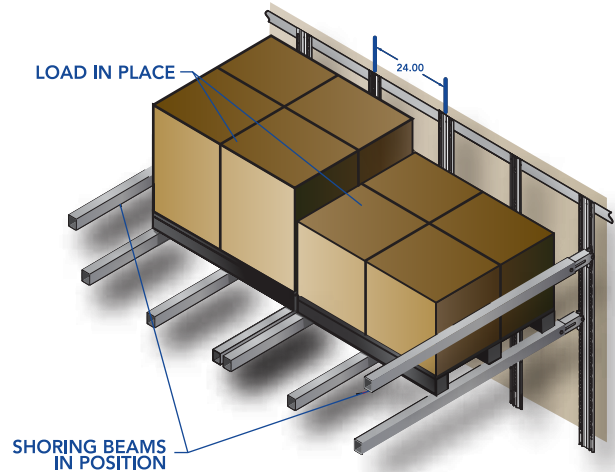

SINGLE & DOUBLE SYSTEM ON 24-IN. CENTERS
(DOUBLE-SINGLE-DOUBLE)
 + Pallets rest on 3 individual beams

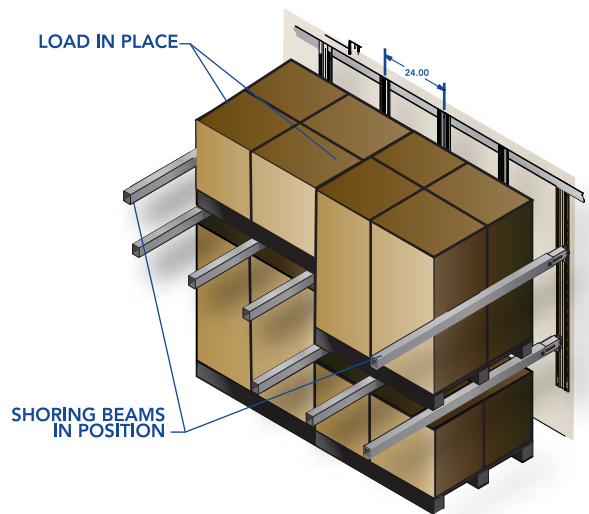

SINGLE & DOUBLE SYSTEM ON 24-IN. CENTERS
(DOUBLE-SINGLE-DOUBLE)
 + Ability to deck at multiple heights

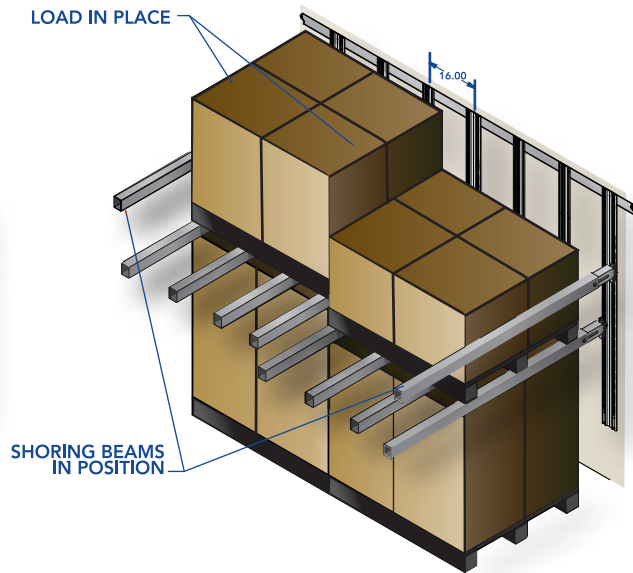

SINGLE & DOUBLE SYSTEM ON 16-IN. CENTERS
(DOUBLE-SINGLE-SINGLE-DOUBLE)
 + Ability to deck at multiple heights

CUSTOMIZATION

An Ankra Deck System Specialist can assist in determining the Lift-A-Deck II configuration that best meets your fleet's needs.

MAXIMIZE PROFITS

Increase load average and maximize profits for every load with the easily adapted Lift-A-Deck II system.

TRACK



49562-17-72.00

*Standard Single Row S-Track
72-inch
Weight - 2.70 lbs.*



50058-18-72.00

*Low Profile Single Row Flanged S-Track
72-inch / Weight - 4.20 lbs.*



50072-14-72.00

*Double Row Flanged S-Track
72-inch / Weight - 6.78 lbs.*

PRECISE

System track precision machined, no lubrication required.

BROAD

Widest choice of track types to meet every application.

CUSTOM

Custom lengths and profiles for specific needs of every fleet.

**STANDARD
TRACK LENGTH
72 INCHES**



ACCESSIBLE

Beam access slot allows easy beam removal and replacement.

THE DECK SYSTEM SPECIALISTS

DECKING SHORING BEAMS

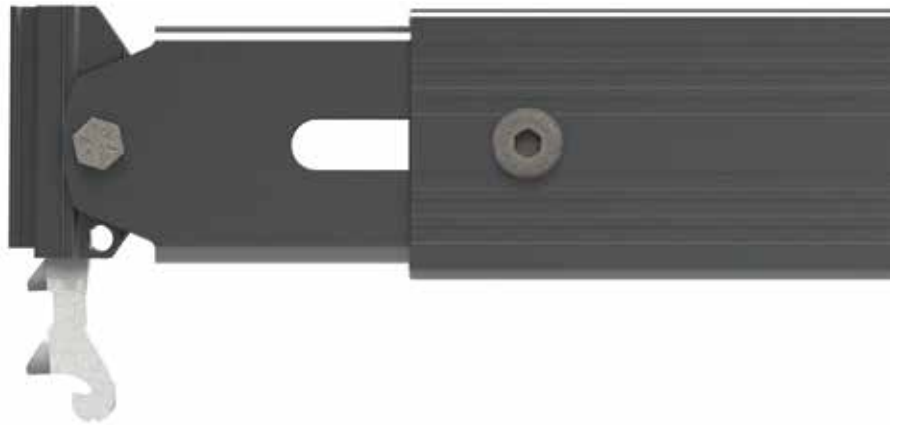

REDESIGNED

Updated foot assembly is engineered to allow the inspection of both locking lugs without removing beams from their track.

SECURE

High strength design prevents beams from jamming in the track if hit by a forklift.

CONVENIENT

When not in use, beams conveniently store in the ceiling. No more beams left behind on loading docks.



49414-15

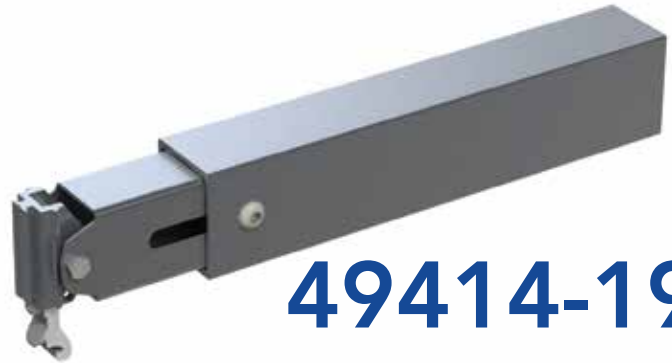

49414-19

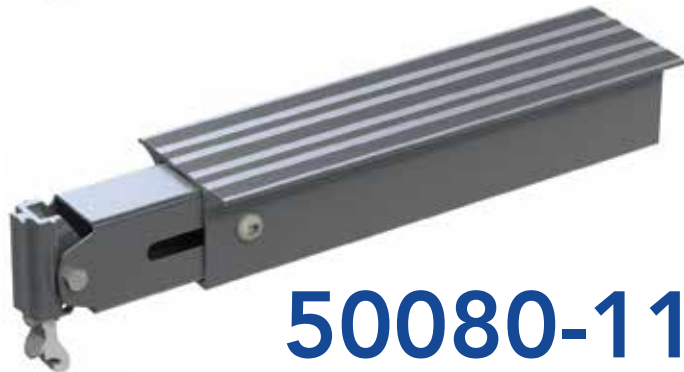

50080-11



50312-10

	WLL Decking	WLL Shoring	Max Cargo	Weight
49414-15 Standard Duty Beam	2,200 lbs	2,200 lbs	550 lbs	18.1 lbs
49414-19 Heavy Duty Beam	3,000 lbs	2,500 lbs	750 lbs	19.7 lbs
50080-11 Wide Flanged Beam	4,000 lbs	Not Recommended	1,000 lbs	24.9 lbs
50312-10 Reinforced Wide Flanged Beam	4,000 lbs	2,500 lbs	1,000 lbs	26.7 lbs

*Max cargo is the maximum recommended cargo weight per beam, to allow for expected 4G transport dynamics.