

INSTALLATION GUIDE

AMP Research Power Step

MADE IN USA

APPLICATION

AMP Part

Ram 1500	Crew Cab	2009-2012	77158-01A
Ram 2500/3500	Crew Cab	2010-2012	77158-01A

Note: The application works only on the Crew Cab model Vehicles.

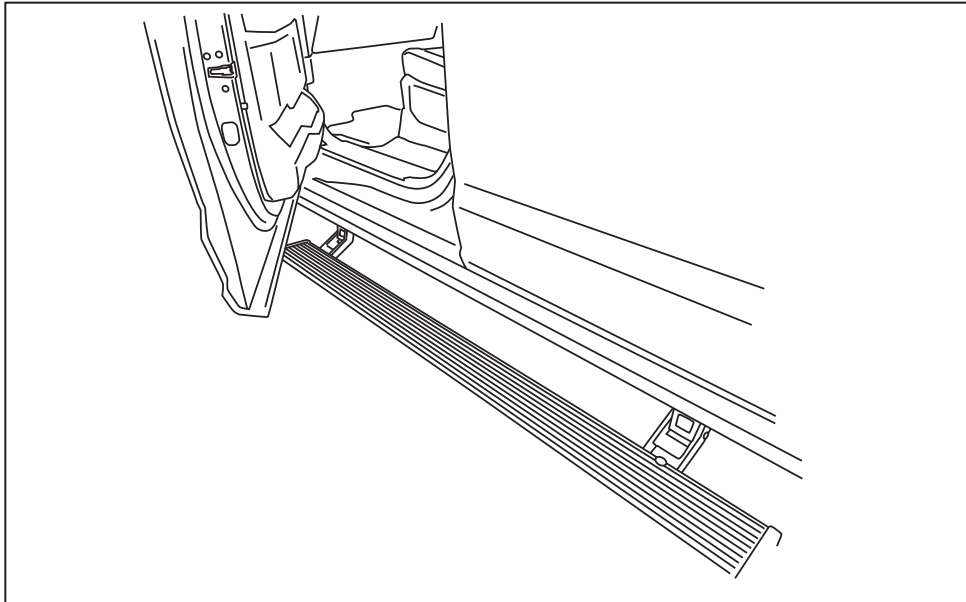

INSTALLATION TIME

3-5 Hours

Professional installation recommended

SKILL LEVEL



4= Experienced

TOOLS REQUIRED

- Safety goggles
- Measuring tape
- 10 mm socket
- 13 mm socket
- 1/2" socket
- Ratchet wrench and extension
- Wire crimpers
- Wire stripper / cutter
- 3/16" hex key wrench (allen wrench)
- 4mm hex key wrench (allen wrench)
- Electrical tape
- Weather proof caulking (silicone sealer)
- Silicone spray

WARRANTY

5-Year Limited Warranty

Invented, engineered and manufactured exclusively by AMP Research in the USA. May be covered by one of the following patents: 6,641,158; 6,830,257; 6,834,875; 6,938,909; 7,055,839; 7,380,807; 7,398,985; 7,584,975 ©2012 AMP Research. All rights reserved. Printed in USA.

INSTALLATION GUIDE

Attaching motor to Linkage assembly.

EXPLODED VIEW

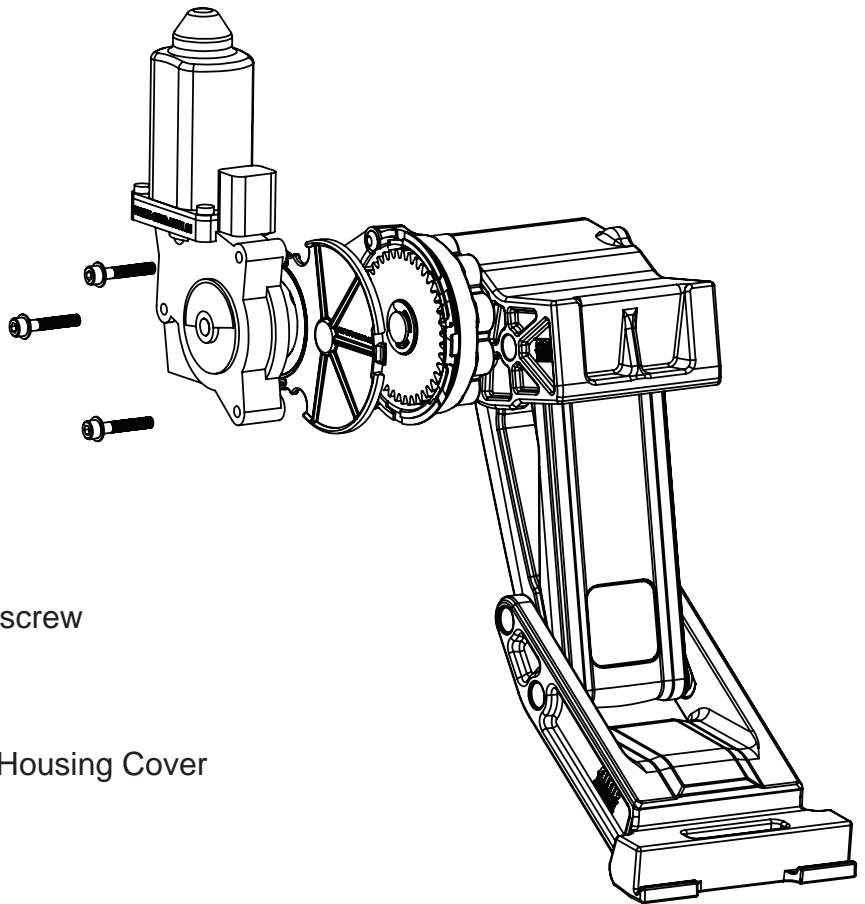

80-03129-90	Motor
19-03179-90	Socket cap screw
19-03133-90	Washer
19-03138-90	Drive Gear Housing Cover

CAUTION: HANDLE WITH CARE.

To ensure our customers receive all components with full integrity, we pack the motors separate from their linkage assemblies. This requires that the installer position and fasten the motor before continuing with the install. Please follow the instructions below and handle the assembly carefully.

CAUTION: Dropping the assembly or any excessive impact MAY cause damage to the motor.

Instructions:

1. Position the gear cover in place as shown if not already in place.
2. Seat motor into position on the three mounting bosses. This may require an adjustment of the gear by moving the swing arms.
3. After seating into place, fasten the motor with the three motor mount screws with 4mm Hex Head. Tighten screws to 36 in-lbs (4N-m). **Do not over torque.**

AMP RESEARCH POWERSTEP™ – Ram Crew Cab

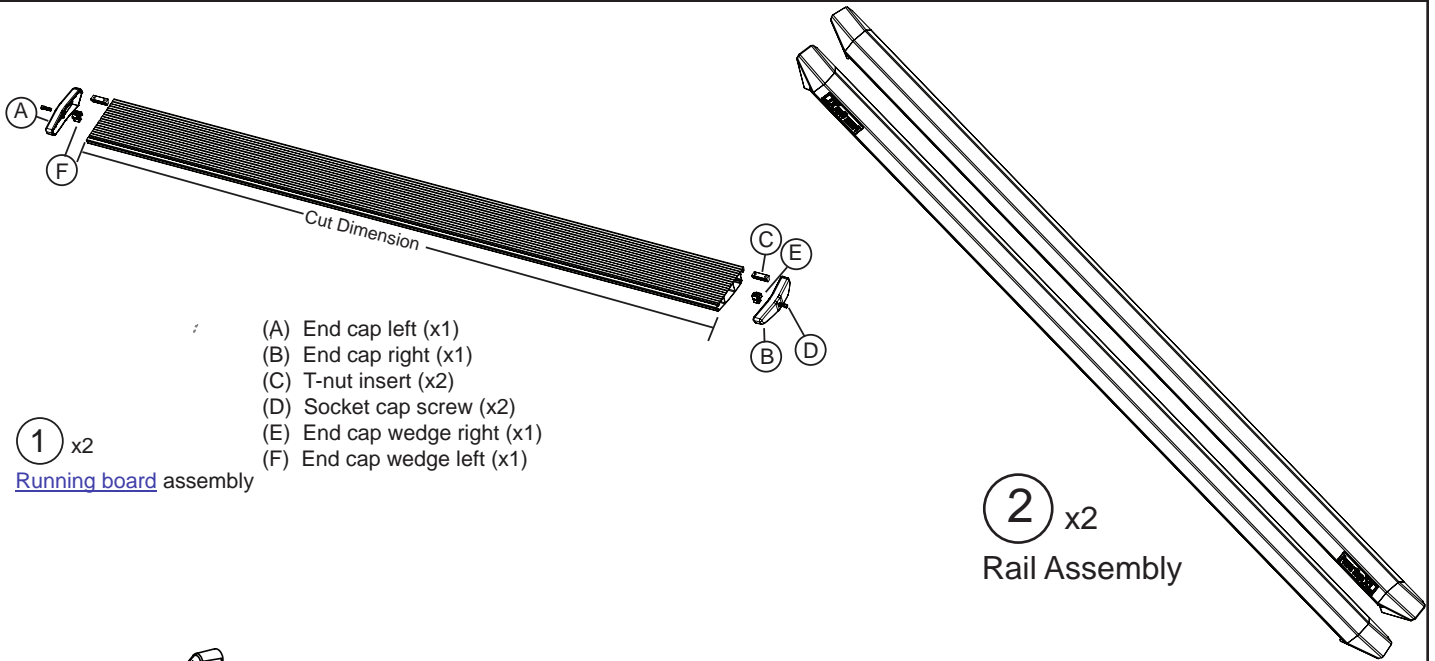

- (A) End cap left (x1)
- (B) End cap right (x1)
- (C) T-nut insert (x2)
- (D) Socket cap screw (x2)
- (E) End cap wedge right (x1)
- (F) End cap wedge left (x1)

1 x2
Running board assembly

2 x2
Rail Assembly

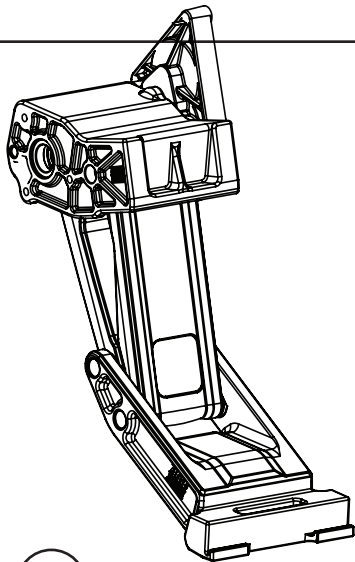

3
Motor Linkage assembly
Driver

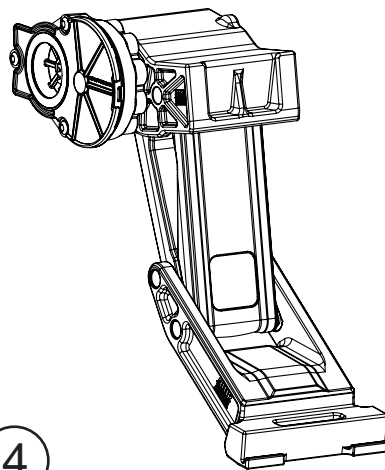

4
Motor Linkage assembly
Passenger

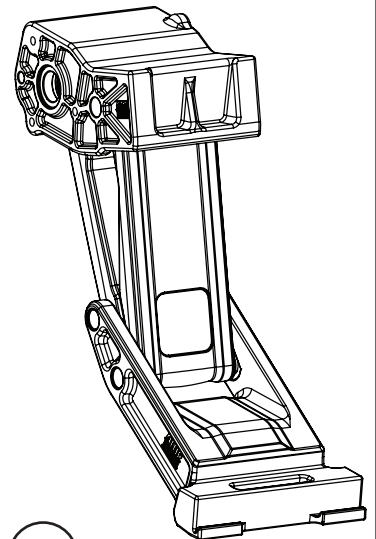

5 x2
Idler Linkage assembly

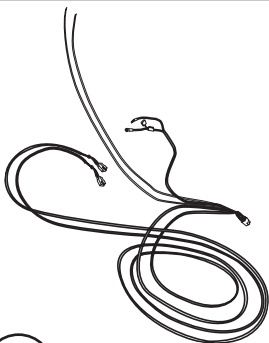

6
Wire harness

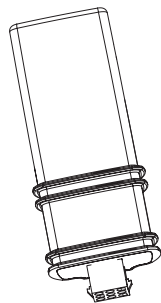

7
A06 Controller



8 x4
Posi-Tap™

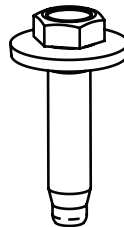

9 x16
M8 Hex Bolt w
Conical washer

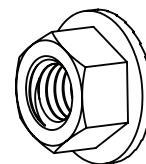

10 x12
5/16-18
Flange Nut

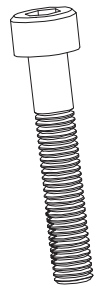

11 x6
M5 Hex Bolt

AMP RESEARCH POWERSTEP™ – Ram Crew Cab



12 x6
M5 Washer

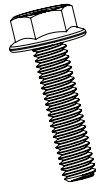

13 x4
M6 Flange Bolt

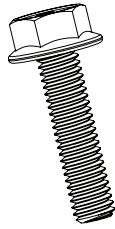

14 x4
5/16 Flange Bolt

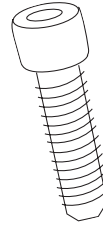

15 x8
Socket Cap Screw

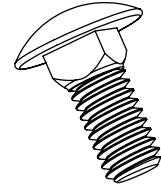

16 x8
5/16-18
Carriage Bolt

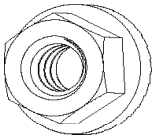

17 x8
1/4-20
Flange nut

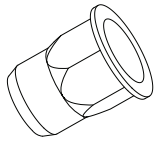

18 x8
Rivet Nut



19 x8
Button Head Torx
Screw



20 x8
Washer

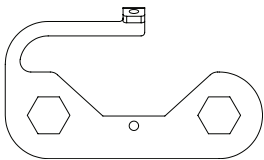

21 x4
Reinforcement Bracket

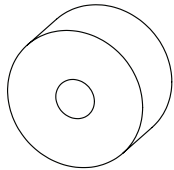

22 x4
Upper Mount
Spacer



23 x4
Blind Rivet

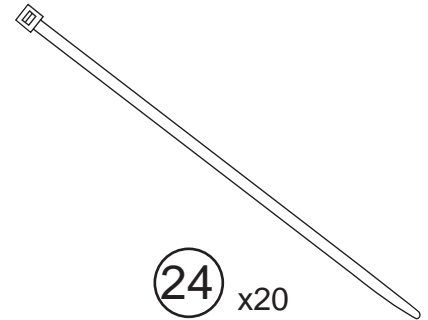

24 x20
Cable tie (7")

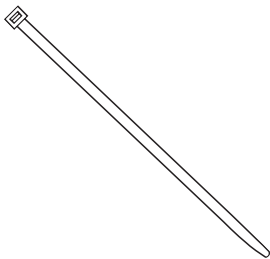

25 x2
Cable tie (11")

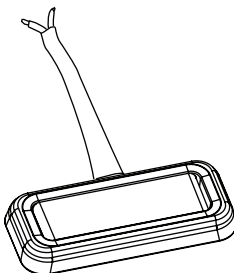

26 x4
LED Lamp

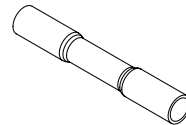

27 x8
Butt Connector

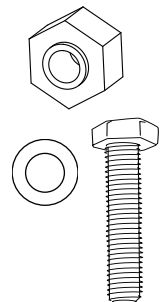

28
Rivet Nut Tool

AMP RESEARCH POWERSTEP™ – Ram Crew Cab

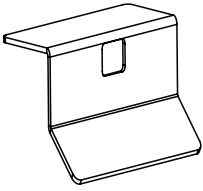

29 x4
LED Light Bracket

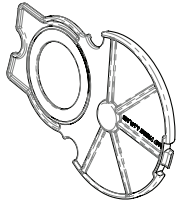

30 x2
Gear Cover

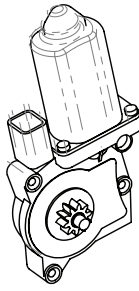

31 x2
Motor

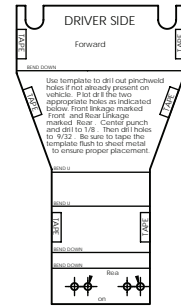

32 x2
Drill Templates
(Driver & Passenger)

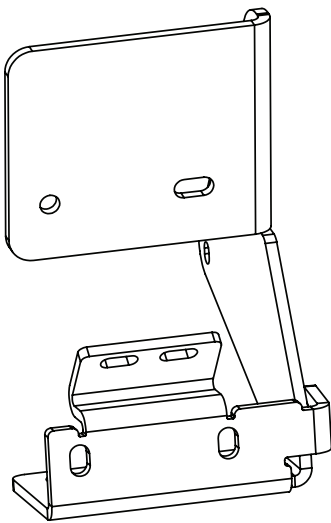

33
Linkage Mounting
Bracket Passenger

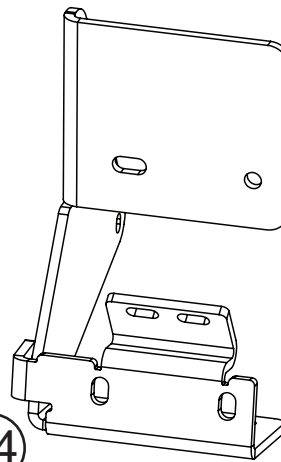

34
Linkage Mounting
Bracket Driver

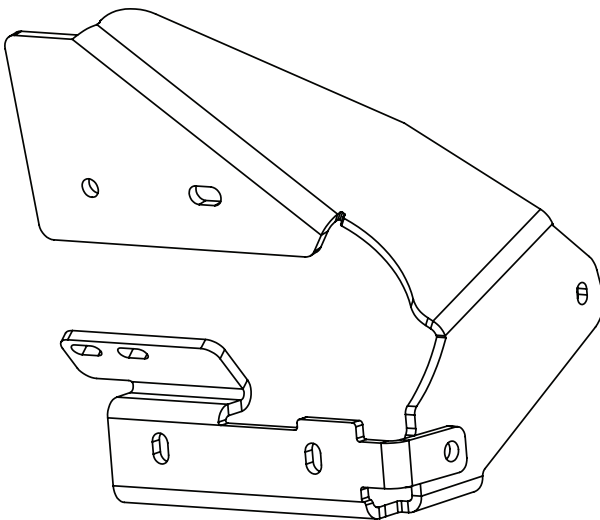

35
Rail Mounting
Bracket Passenger

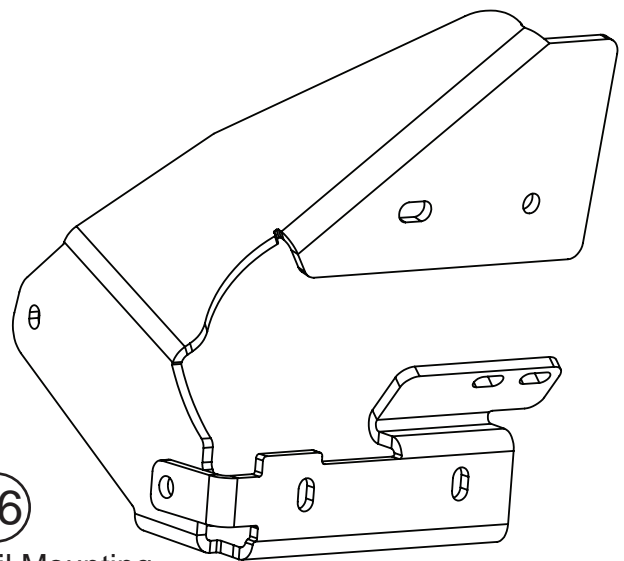

36
Rail Mounting
Bracket Driver

HARDWARE MOUNTING OVERVIEW (passenger side shown)

Locate forward most and rearward most mounting provisions on inner sill of truck. Remove tape from sill drain hole at both mounting points.

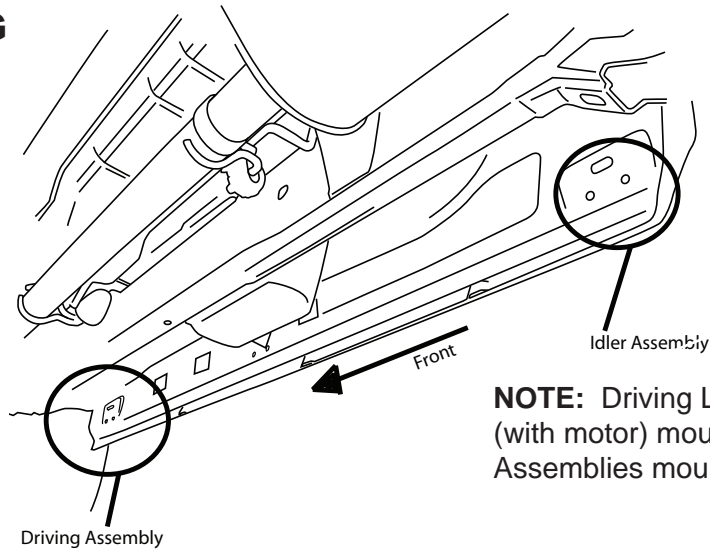

NOTE: Driving Linkage Assemblies (with motor) mount in the front; Idler Assemblies mount in the rear.

1

Set Reinforcement Plate in place and locate with rivet nuts. Drill hole using an 1/8" drill bit. After drilling apply paint to prevent rusting

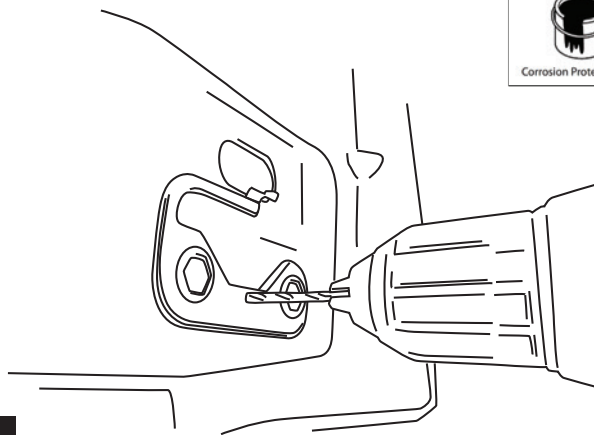

2

Once hole is drilled insert a piece of string or wire through hole in Reinforcement Plate. Set plate into position.

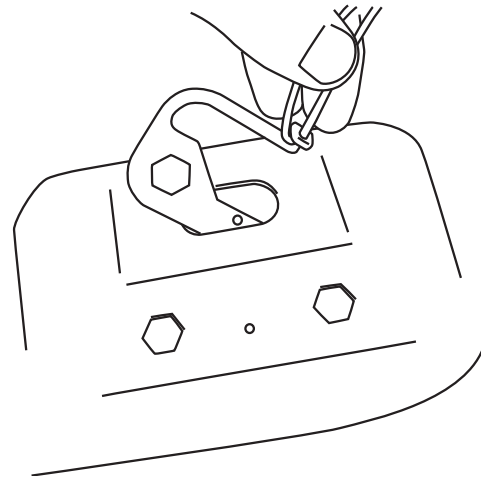

3

Set rivet nuts into place for alignment. Insert pop rivet through hole in plate and secure in place. Once pop rivet is installed remove string or wire from Reinforcement Plate. **NOTE: Verify plate is pulled flush to the body before securing pop rivet.**

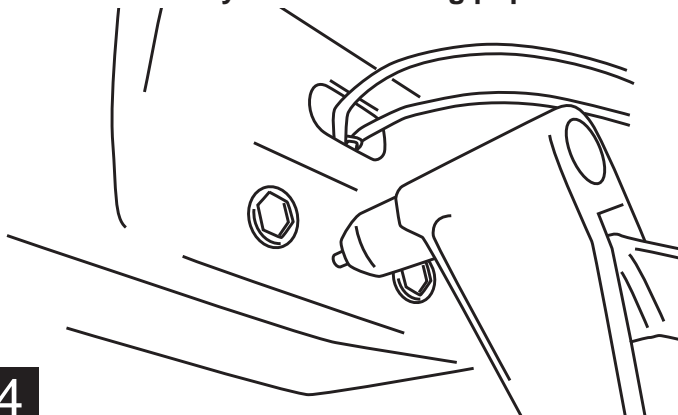

4

Assemble Hex Bolt (lubricated with soapy water), Washer, Rivet Tool, and Rivet Nut together as shown and place into hex cutouts in sill. An extra Hex Bolt and M8 Washer is supplied to install rivet nuts.

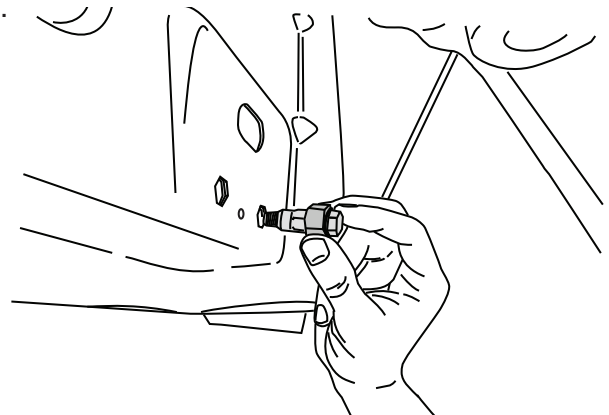

5

AMP RESEARCH POWERSTEP™ – Ram Crew Cab

With Rivet Nut Tool held in place with 19mm wrench, tighten Hex Bolt until Rivet Nut deforms and secures itself to the sheet metal (110 in-Lbs. or 4 turns). Remove Hex Bolt and Rivet Nut Tool. Repeat for each of the four mentioned mounting locations.

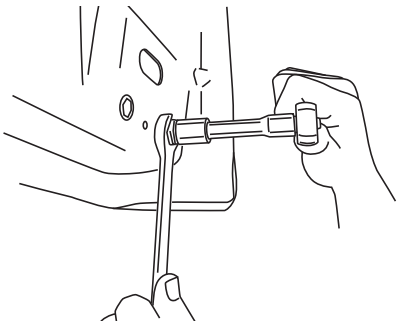

WARNING: Rivet Nuts not properly collapsed will not hold securely to sheet metal.

NOTE: Hold Rivet tool with wrench while loosening bolt.

6

Once rivet nuts are in place use a screwdriver to push back tab in hole to avoid interference with linkage mount.

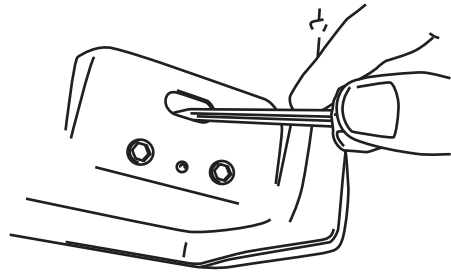

7

NOTE: Models with holes in Pinch Weld Skip to Step #12

Fold both the passenger and driver side templates in the proper direction noted on the template. Thread in hex bolts and slide slots in template up to bolts. Next use tape and apply tape on all surfaces on template that is labeled "Tape". Start at Hex bolts and make sure template is flat on each surface. Work your way down and out.

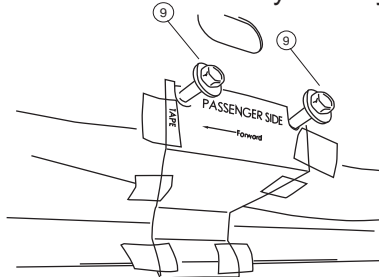
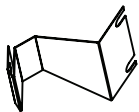

8

Mark appropriate holes as indicated with a center punch. Front linkage marked "Front" and Rear linkage marked "Rear".

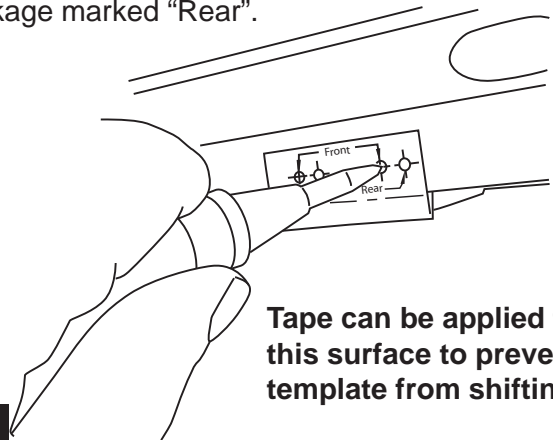

Tape can be applied to this surface to prevent the template from shifting.

9

Using a marker draw cross hatch to verify bit does not walk while drilling.

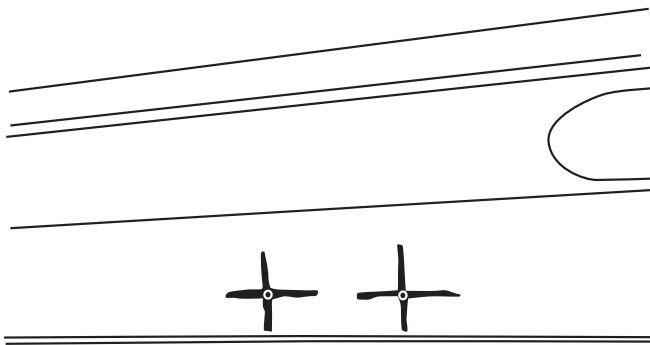

Pre drill hole using an 1/8" drill bit. Next drill holes to 9/32". Deburr all surfaces. NOTE: Filing of hole may be required if drill bit wandered. After drilling apply paint to prevent rusting.

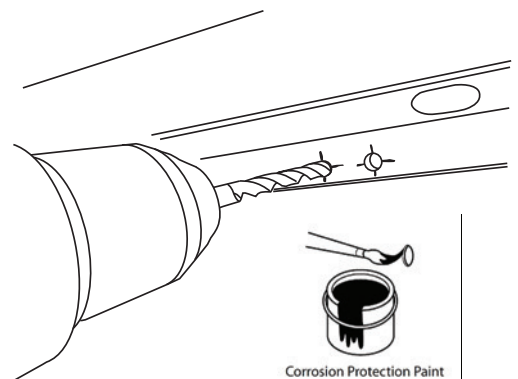

Corrosion Protection Paint

11

10

AMP RESEARCH POWERSTEP™ – Ram Crew Cab

Install Brackets onto vehicle. On Passenger side install Rear Rail Mounting Bracket (35) and Front Linkage Mounting Bracket (33) using the Hardware provided. 4 Conical washer bolts (9), 4 Button Head Torx (19), washers (20) and Flange Nuts (21). Once bolts are tightened up to vehicle torque Conical washer bolts (9) to 16 ft-lbs and Button head Torx to 6ft-lbs.

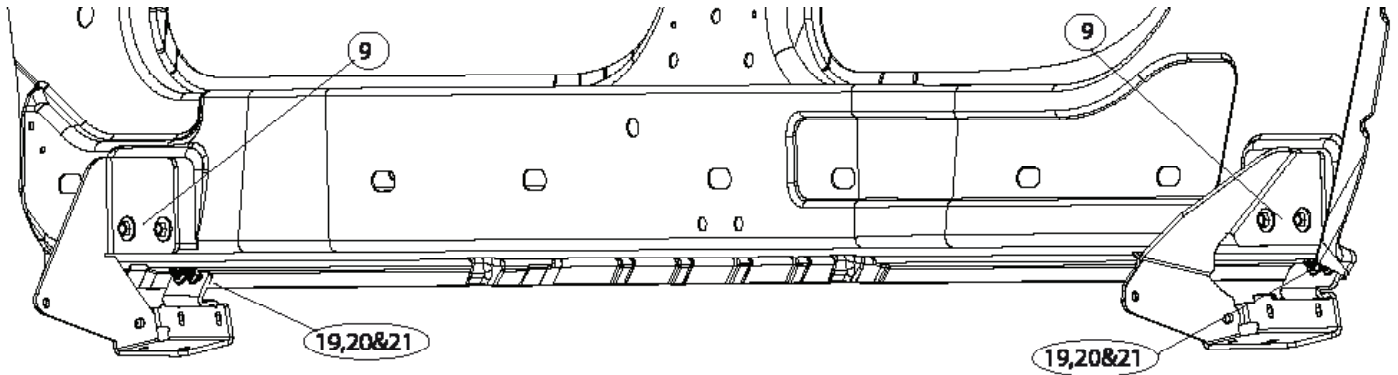

12

Insert and position Carriage bolts (16) into slot on rail (4). Insert from either end of rail. Using Flange Nuts (17) provided assemble rail to Brackets onto the rail. Next install Flange Bolt (14) and Flange Nut (17) onto bracket tab. Driver side shown. Dimensions shown are for reference. **Torque flange nuts to 16ft-lbs.**

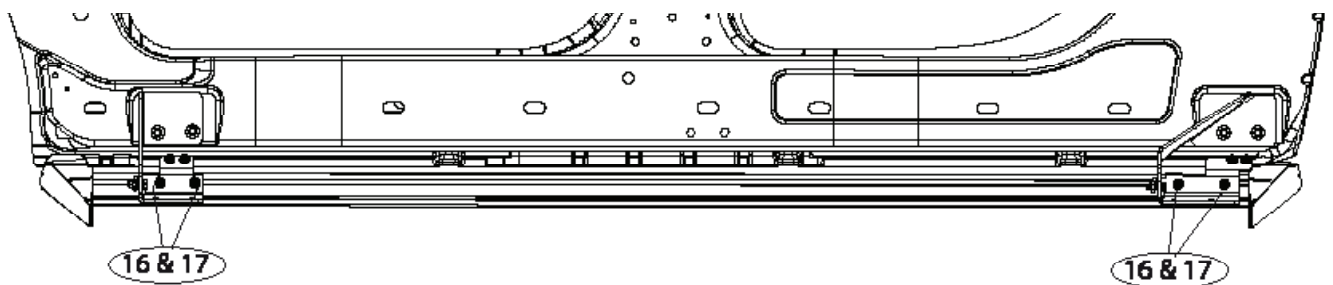

Note: Badge on rail sits towards the rear of the vehicle!

13

AMP RESEARCH POWERSTEP™ – Ram Crew Cab

Thread supplied bolts 2x (9) into Front Drive Linkage. Repeat step for Rear Idler Linkage. Do not tighten.

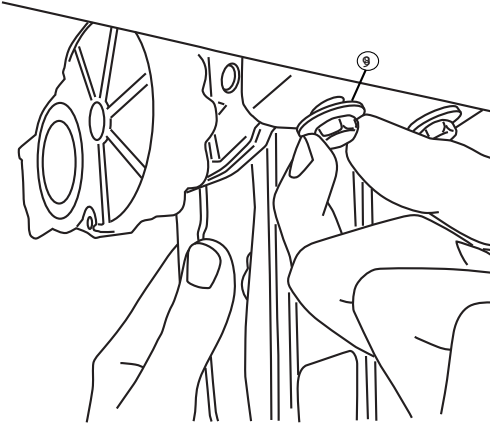

Install provided spacer (22) and M6 bolt (13) into upper mount as shown on both the Drive and Idler linkages. Do not tighten.

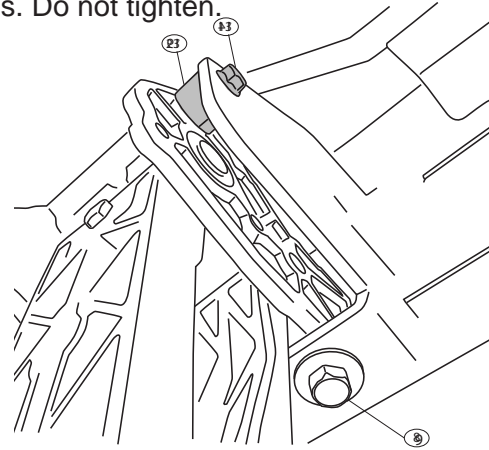

14

15

Slide mounting T-nut into position, Center board in rail pocket. Tighten fasteners to 10 ft-lbs.

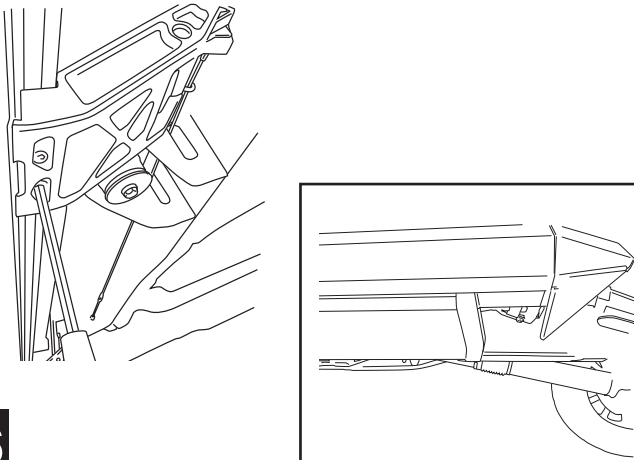

16

17

Using a 13mm socket Torque linkage bolts 4x (9) from step 3 to 16 ft-lbs. Next use a 10mm socket, torque linkage spacer bolt 2x (13) from step 6 to 8 ft-lbs. Once linkages are tight cycle board to verify steps deploy under own weight.

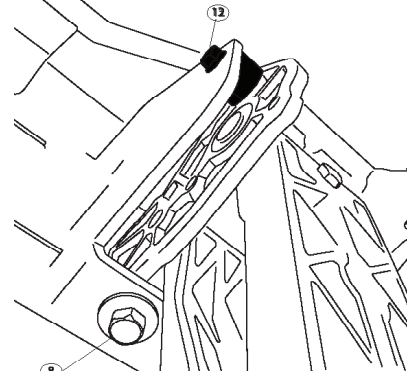

Once linkages are tightened to the bracket tighten bracket tab Flange bolt (14) and Nut (10). Torque to 16 ft-Lbs.

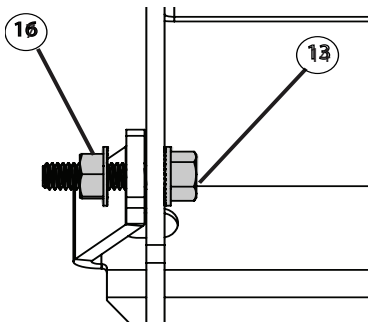

18

Attach motor to linkage. Using a 4mm hex Torque to 36 in-Lbs.

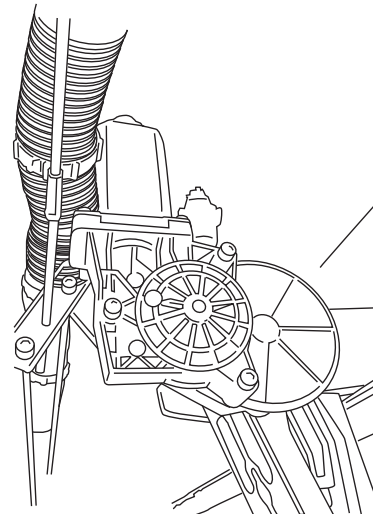

19

AMP RESEARCH POWERSTEP™ – Ram Crew Cab

Prepare large tie-wraps for mounting Power Step Controller. Loosely loop tie-wraps around large bundle of wires behind battery in engine compartment.

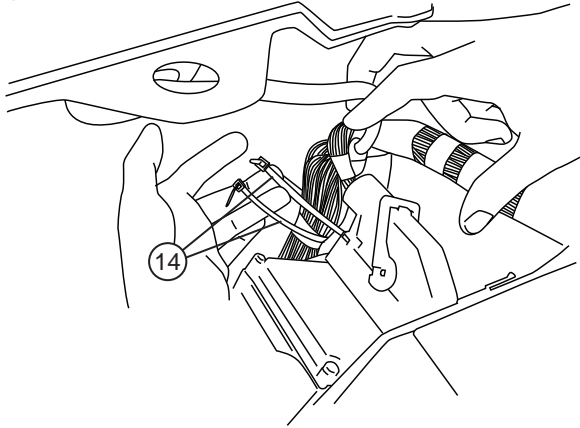

Insert controller into tie-wrap loops and cinch down securely. The tie-wraps should cinch down into channels on controller surface.

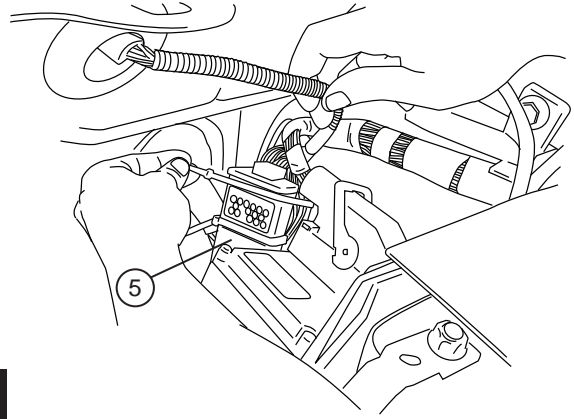

20

21

Remove fuse from Power Step Wire Harness.

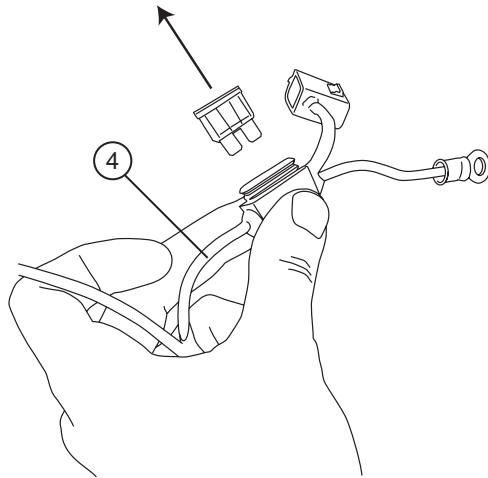

Connect power leads from Controller, Red to positive battery terminal and Black to the vehicle body ground as shown.

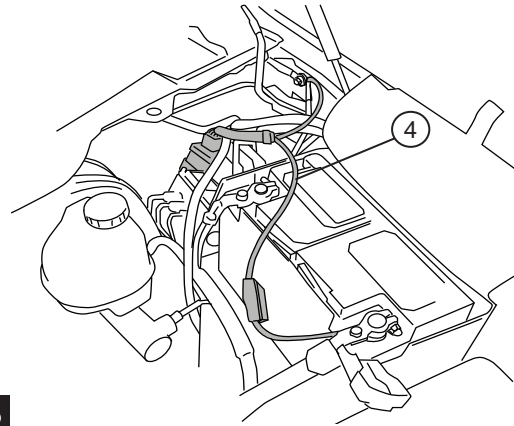

22

23

Splice Power Step trigger wires into the Door Ajar wires with provided Posi-Tap™ splicers. The Power Step trigger wires color coordinate with the factory Door Ajar wires. Follow the steps below to correctly splice wires.

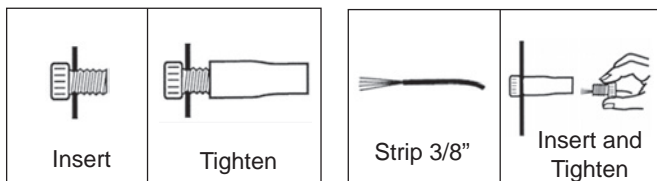

Route the trigger wires of Power Step Harness (Purple wires) down toward the fuse box located in front of the battery.

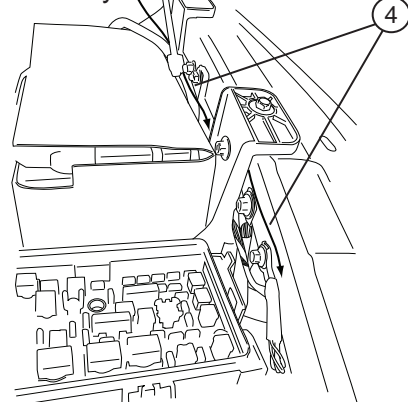

24

25

AMP RESEARCH POWERSTEP™ – Ram Crew Cab

Remove fuse box lid and fuse box power lead with 13mm wrench. While depressing release tabs, lift fuse box to view bottom side.

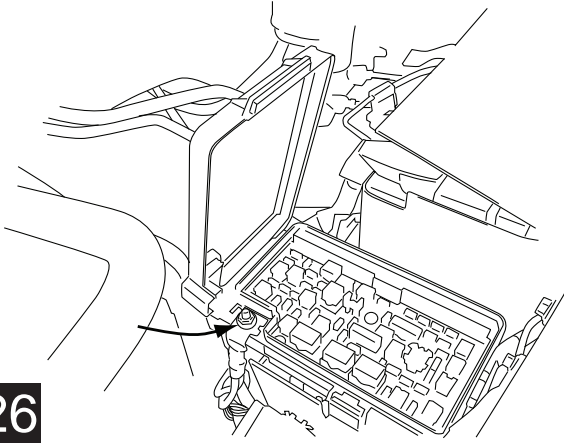

26

Locate and remove Black Connector with Gray latch on bottom side of fuse box (labeled "G" where connected to fuse box).

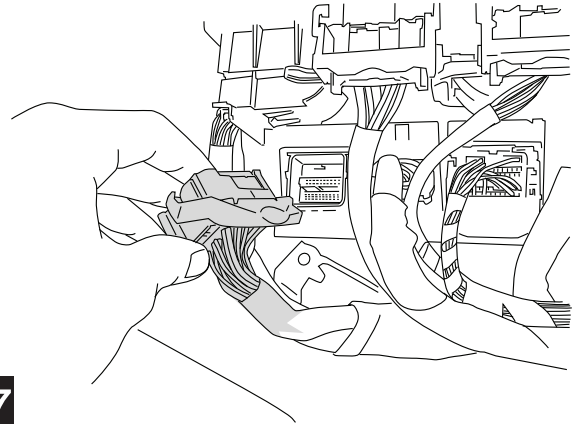

27

Locate the vehicle's Door Ajar Switch wires on the removed connector as indicated in chart and diagram below according to vehicle model year.

Model Year
2011- 2012

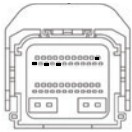

CAVITY	COLOR	FUNCTION
11	VIOLET	DRIVER DOOR AJAR SWITCH SENSE
12	VIOLET / WHITE	PASSENGER DOOR AJAR SWITCH SENSE
16	VIOLET / GRAY	LEFT REAR DOOR AJAR SWITCH SENSE
14	VIOLET / YELLOW	RIGHT REAR DOOR AJAR SWITCH SENSE

Model Year
2009- 2010

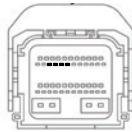

CAVITY	COLOR	FUNCTION
14	VIOLET	DRIVER DOOR AJAR SWITCH SENSE
15	VIOLET / WHITE	PASSENGER DOOR AJAR SWITCH SENSE
16	VIOLET / GRAY	LEFT REAR DOOR AJAR SWITCH SENSE
17	VIOLET / YELLOW	RIGHT REAR DOOR AJAR SWITCH SENSE

28

Splice Power Step trigger wires into the Door Ajar wires with provided Posi-Tap™ splicers. The Power Step trigger wires color coordinate with the factory Door Ajar wires. Follow the steps below to correctly splice wires.

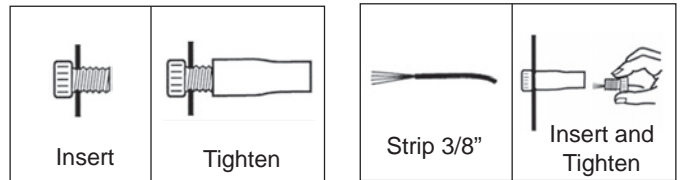

29

With Posi-Taps securely in place, carefully replace connector and drop wire bundles and fuse box back into place. Reattach fuse box power lead that was removed in previous step.

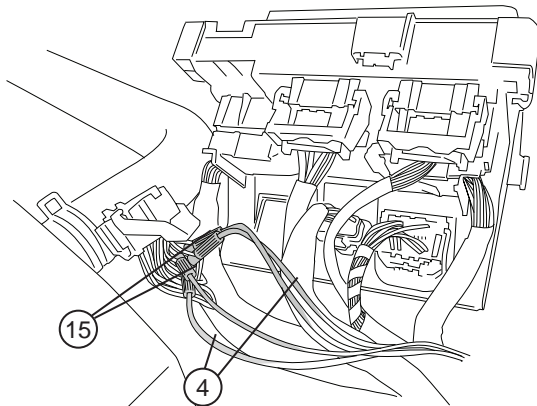

30

Route the two Wire Harness legs down over the wheel wells toward Motor Linkages, long leg across to the passenger side. Secure harness with tie wraps.

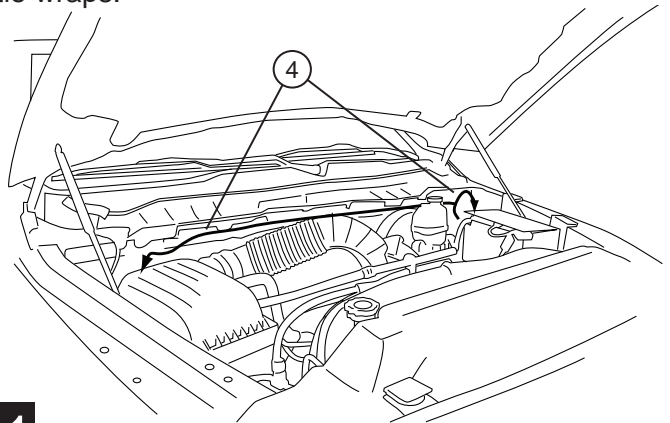

31

AMP RESEARCH POWERSTEP™ – Ram Crew Cab

On driver side, run Wire Harness leg down and along underside of the vehicle floor and frame to front Drive Linkage. Connect harness to motor and secure harness with tie wraps. Route remainder of wire harness towards rear linkage assembly for LED lights

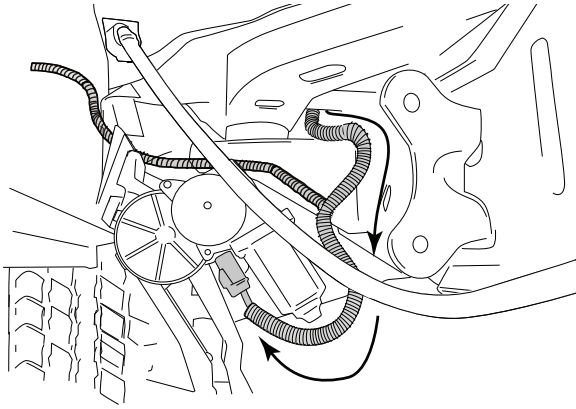

32

On Passenger Side, run Wire Harness leg down and along underside of the vehicle floor and frame to front Drive Linkage. Connect harness to motor and secure harness with tie wraps. Route remainder of wire harness towards rear linkage assembly for LED lights

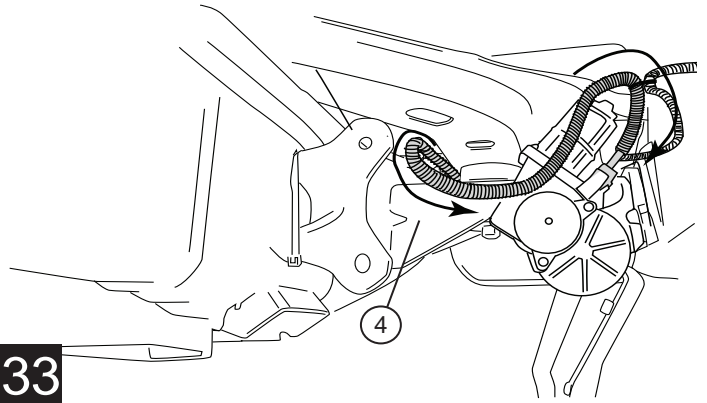

33

Affix LED lamp (20) to LED Bracket (22) as shown..

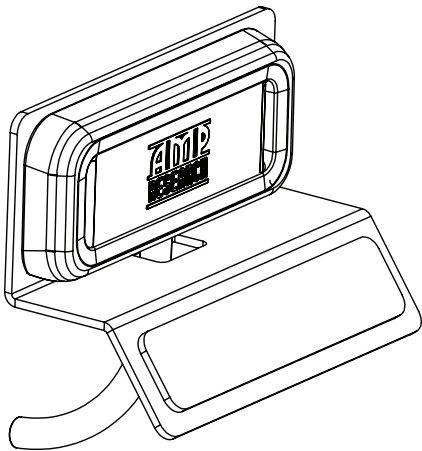

34

Affix LED light bracket assembly to rail. Mount front light rearward of front linkage and mount rear light just forward of rear linkage.

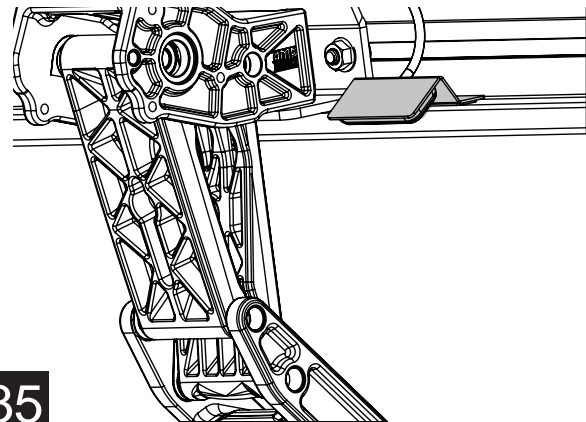

35

Using supplied butt connectors, connect the lamp wires. Red to Red, Black to Black. Once Crimped use heat gun to shrink tube. Close and wrap conduit with electrical tape. Secure all loose wires with cable ties. Pull lamp wires upward to avoid any wire snagging.

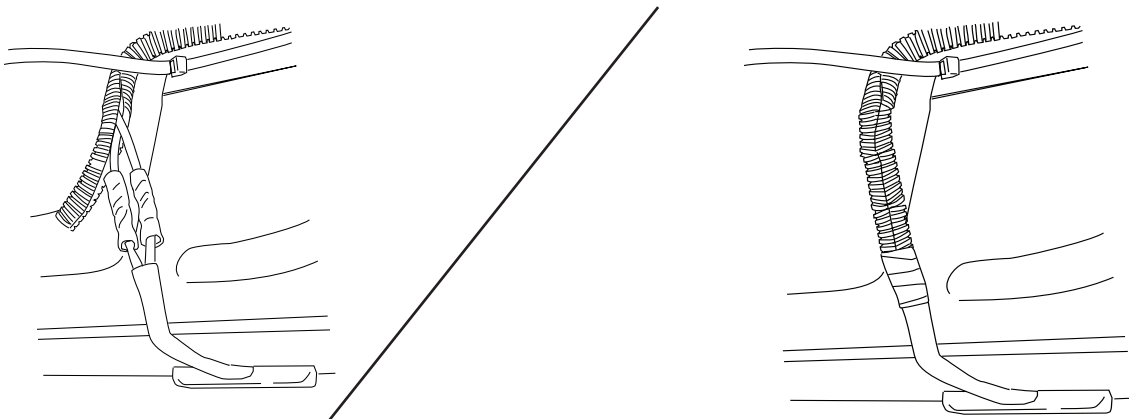

36

Reinstall Fuse and check that all doors activate the Power Step and the LED Lights work when doors open and close. Reinstall any remaining trim panels.

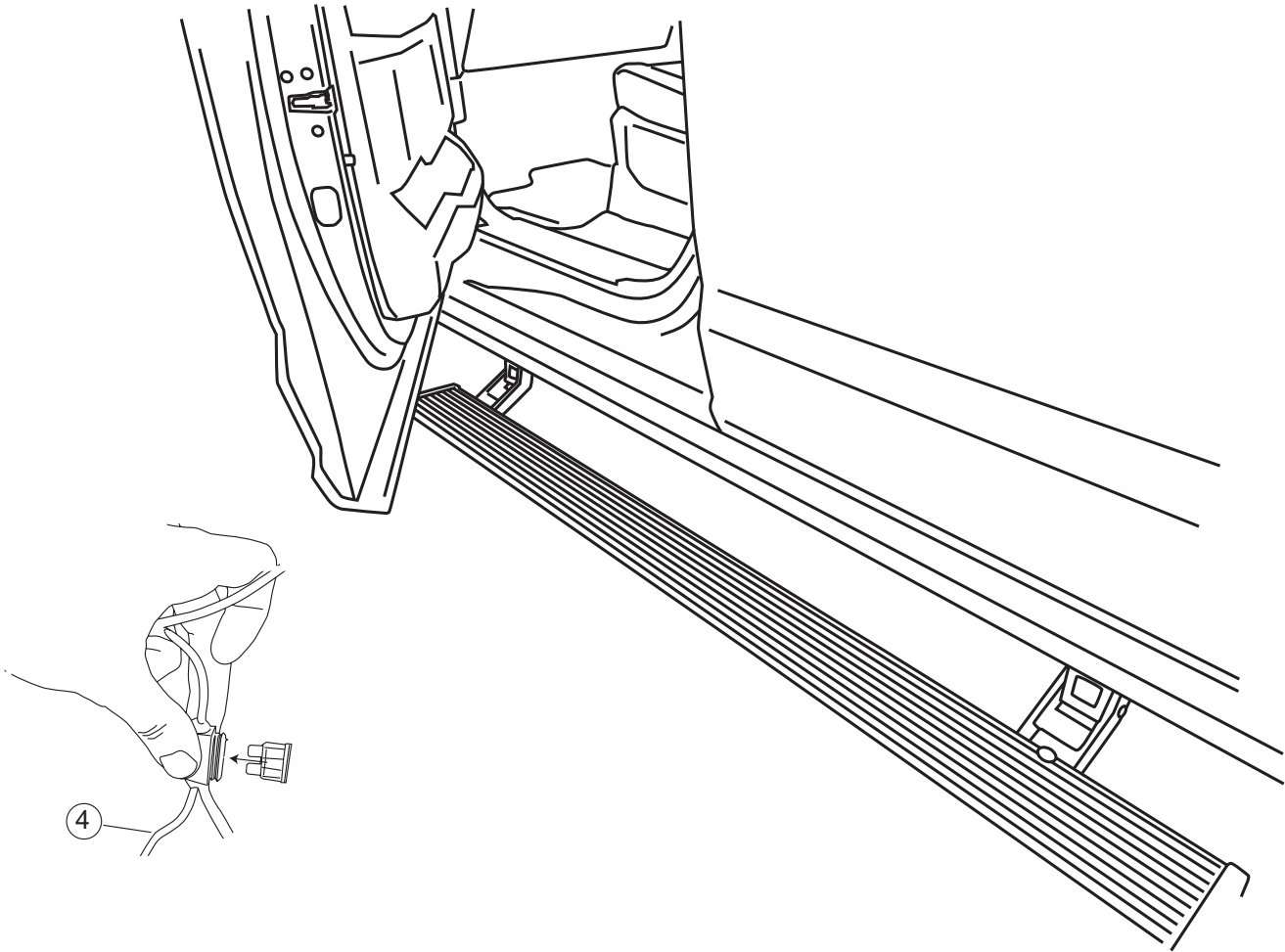

FINAL SYSTEM CHECK

Check that all doors activate the PowerStep and the LED lights work when doors open and close.

NORMAL OPERATION: When the doors open, PowerStep automatically deploys from under the vehicle.

When the doors are closed, PowerStep will automatically return to the stowed/retracted position. **Note that there is a 2-second delay before the PowerStep returns to the stowed/retracted position.**

CORRECT OPERATION OF LIGHTS: All four lamps will illuminate upon opening any door of vehicle. Lamps will stay on until restowing of both Power Steps or until 5 minutes has expired with the doors open. When the lights timeout after 5 minutes, they can be reilluminated by closing and opening any door of vehicle.