

INSTALLATION GUIDE

AMP RESEARCH Power Step

MADE IN USA

APPLICATION

AMP Part #

Ford F150 - SuperCrew 2015

77151-01A

Note: The application works only on the Super Crew model Vehicles.

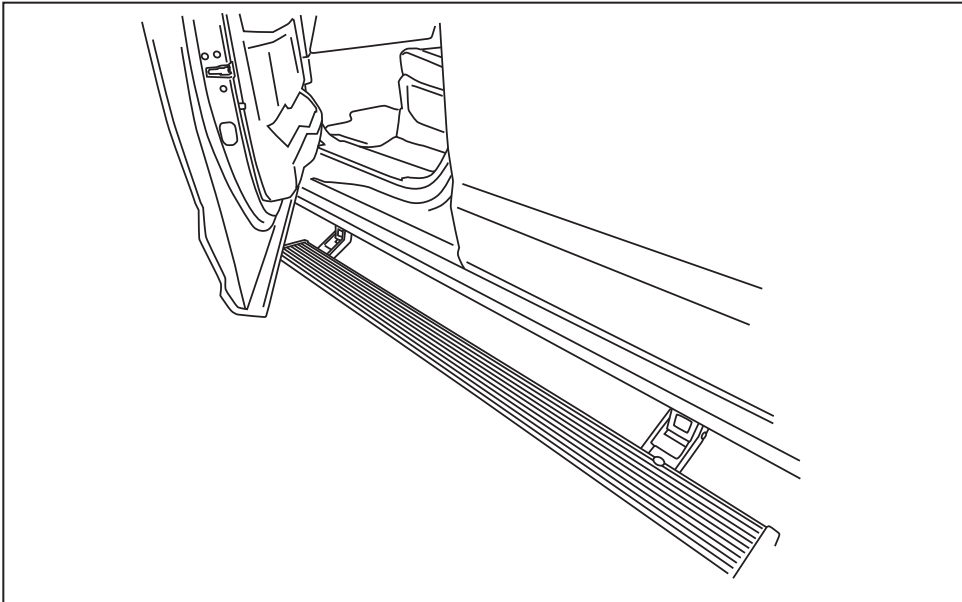

INSTALLATION TIME

3-5 Hours

Professional installation recommended

SKILL LEVEL



4= Experienced

TOOLS REQUIRED

- Safety goggles
- Measuring tape
- 10 mm socket
- 13 mm socket
- 1/2" socket
- Ratchet wrench and extension
- Wire crimpers
- Wire stripper / cutter
- 3/16" hex key wrench (allen wrench)
- 4mm hex key wrench (allen wrench)
- Electrical tape
- Weather proof caulking (silicone sealer)
- Silicone spray

INSTALLATION GUIDE

Attaching motor to Linkage assembly.

EXPLODED VIEW

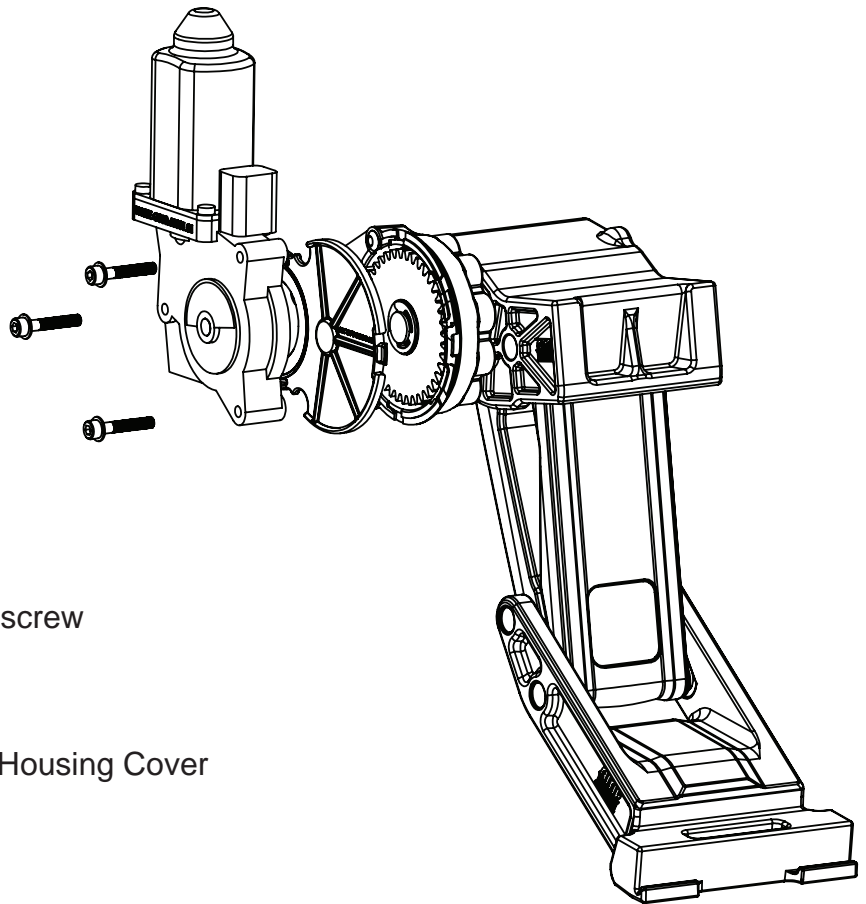

80-03129-90	Motor
19-03179-90	Socket cap screw
19-03133-90	Washer
19-03138-90	Drive Gear Housing Cover

CAUTION: HANDLE WITH CARE.

To ensure our customers receive all components with full integrity, we pack the motors separate from their linkage assemblies. This requires that the installer position and fasten the motor before continuing with the install. Please follow the instructions below and handle the assembly carefully.

CAUTION: Dropping the assembly or any excessive impact MAY cause damage to the motor.

Instructions:

1. Position the gear cover in place as shown if not already in place.
2. Seat motor into position on the three mounting bosses. This may require an adjustment of the gear by moving the swing arms.
3. After seating into place, fasten the motor with the three motor mount screws with 4mm Hex Head. Tighten screws to 36 in-lbs (4N-m). **Do not over torque.**

AMP RESEARCH POWERSTEP™ – FORD F150

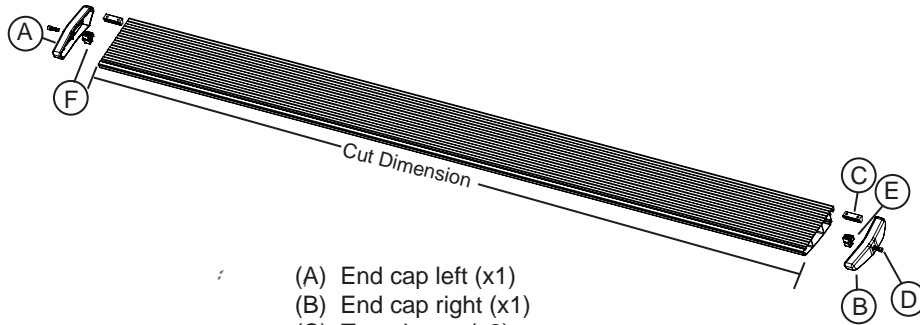

- (A) End cap left (x1)
- (B) End cap right (x1)
- (C) T-nut insert (x2)
- (D) Socket cap screw (x2)
- (E) End cap wedge right (x1)
- (F) End cap wedge left (x1)

1 x2

Running board assembly

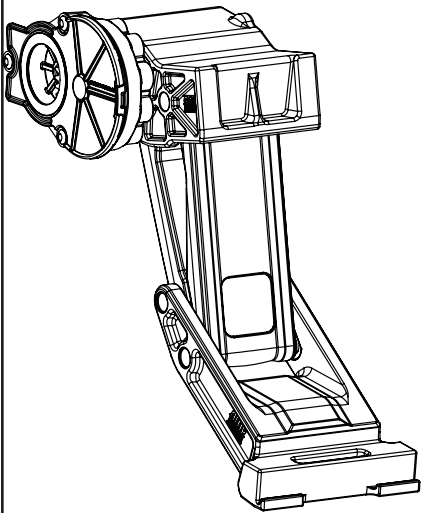

2 x2

Motor Linkage assembly

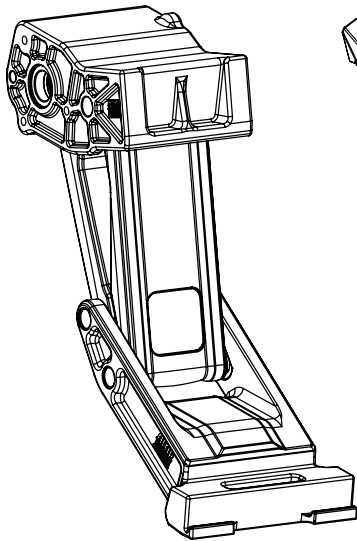

3 x2

Idler Linkage assembly

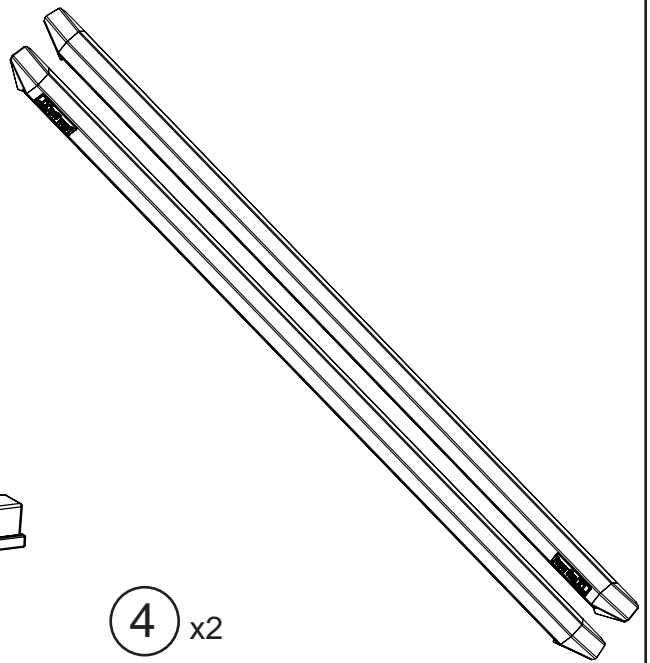

4 x2

Rail Assembly

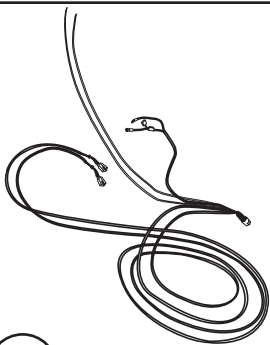

5

Wire harness

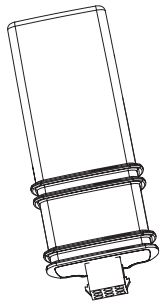

6

A06 Controller



7 x2

Posi-Lock™

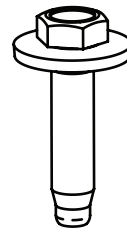

8 x8

M8 Hex Bolt w
Conical washer

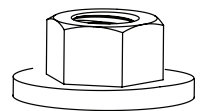

9 x16

M8 Nut w Conical
washer

AMP RESEARCH POWERSTEP™ – FORD F150

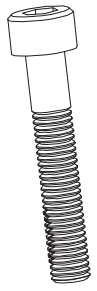

10 x6
M5 Hex Bolt



11 x6
M5 Washer

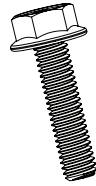

12 x4
M6 Flange Bolt

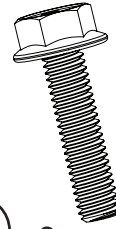

13 x6
5/16 Flange Bolt

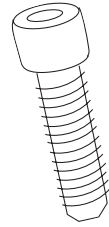

14 x8
Socket Cap Screw

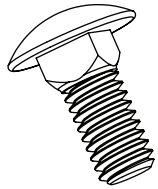

15 x10
5/16-18
Carriage Bolt

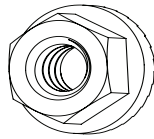

16 x16
5/16-18
Flange nut

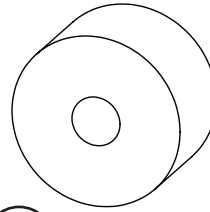

17 x4
Upper Mount
Spacer

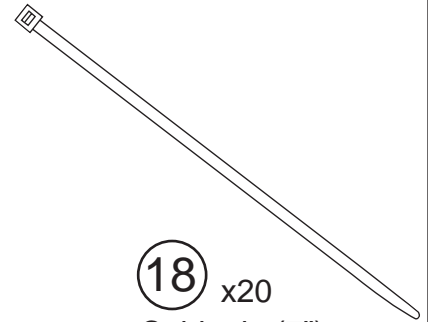

18 x20
Cable tie (7")

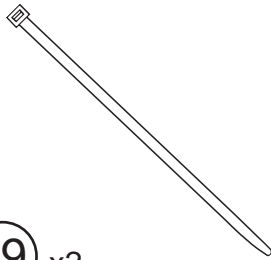

19 x2
Cable tie (11")

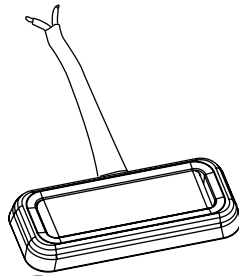

20 x4
LED Lamp

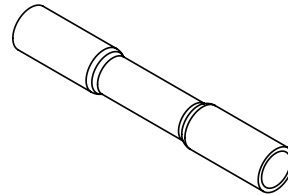

21 x8
Butt Connector

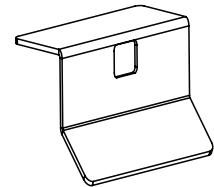

22 x4
LED Light Bracket

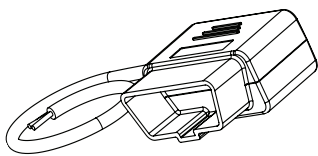

23
OBD II Plug

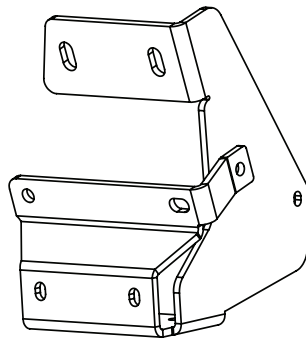

24 x4
Linkage Mounting
Bracket

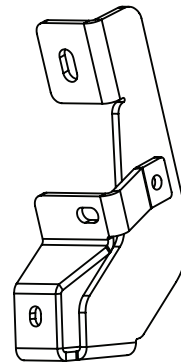

25 x2
Rail Mounting
Bracket

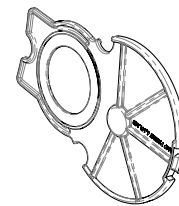

26 x2
Gear Cover

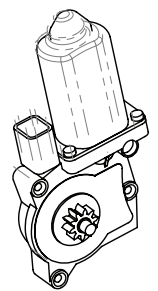

27 x2
Motor

AMP RESEARCH POWERSTEP™ – FORD F150

Insert and position Carriage bolts (15) into slot on rail (4). Insert from either end of rail. Using Flange Nuts (16) provided assemble Brackets 2x (24) & 1x (25) onto the rail (4). Next install Flange Bolt (13) and Flange Nut (16) onto bracket tab. Driver side shown. Dimensions shown are for reference. **Do not tighten this will allow for rail adjustment when mounted onto vehicle.**

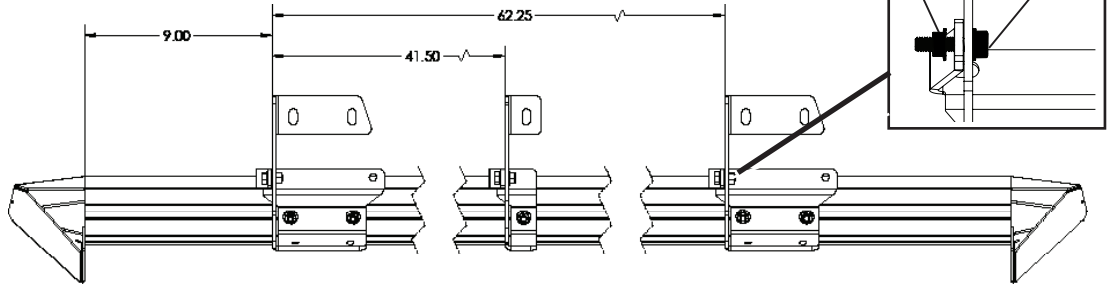
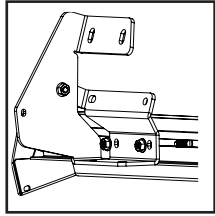

Rear Of Vehicle

Front Of Vehicle

1

Note: Badge on rail sits towards the rear of the vehicle!

Set rail up into position. Starting with the rear bracket work towards the two front brackets. Slide Brackets over captive studs and use provided Nuts 8x (9). Snug to body and torque to 16 ft-lbs

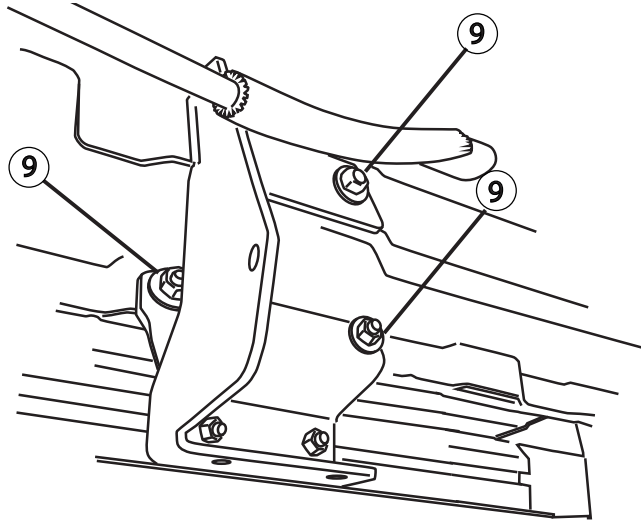

2

Start from rear of vehicle and Torque 5x Flange Nuts (16) to 16 ft-lbs.

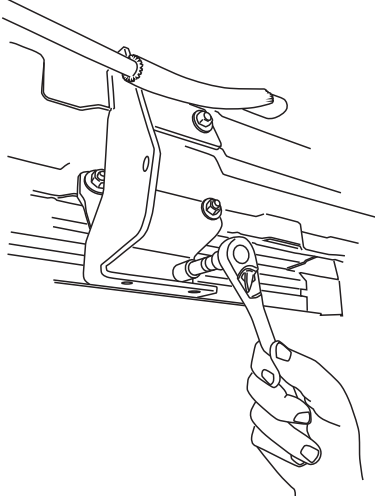

3

Thread supplied bolts 2x (8) into Front Drive Linkage. Repeat step for Rear Idler Linkage. Do not tighten.

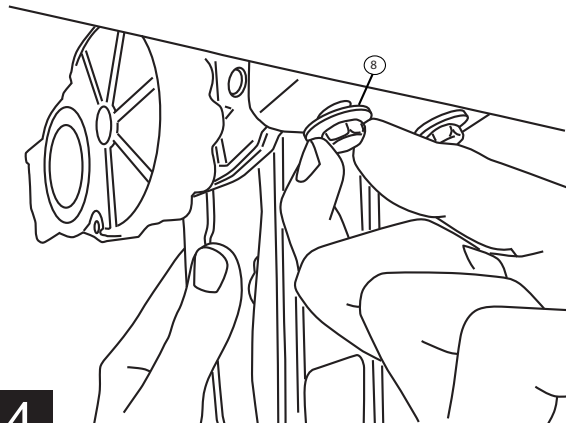

4

AMP RESEARCH POWERSTEP™ – FORD F150

Install provided spacer (17) and M6 bolt (12) into upper mount as shown on both the Drive and Idler linkages. Do not tighten.

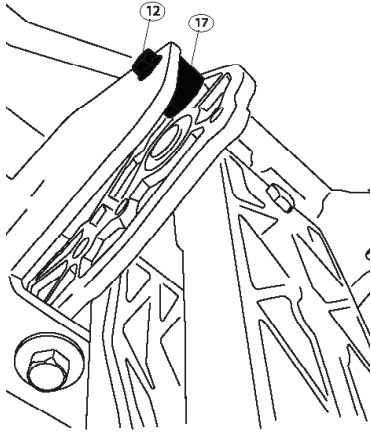

5

Slide mounting T-nut into position, Center board in rail pocket. Tighten fasteners to 10 ft-lbs.

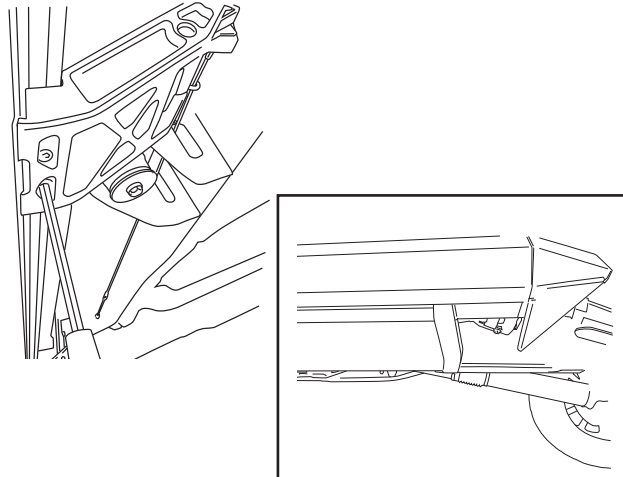

6

Using a 13mm socket Torque linkage bolts 4x (8) from step 5 to 16 ft-lbs Next use a 10mm socket, torque linkage spacer bolt 2x (12) from step 6 to 8 ft-lbs. Once linkages are tight cycle board to verify steps deploy under own weight.

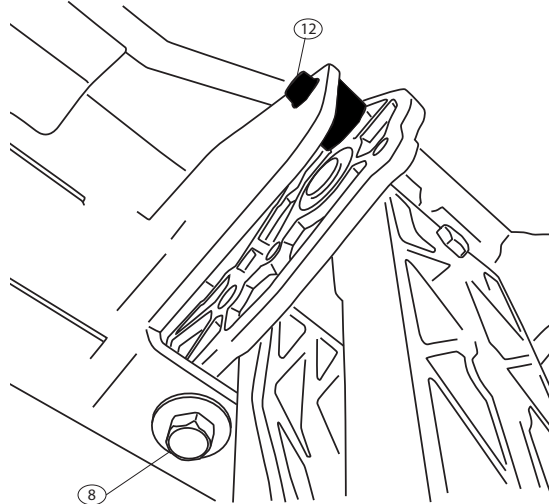

7

Attach motor to harness. Using a 4mm hex Torque to 36 in-Lbs.

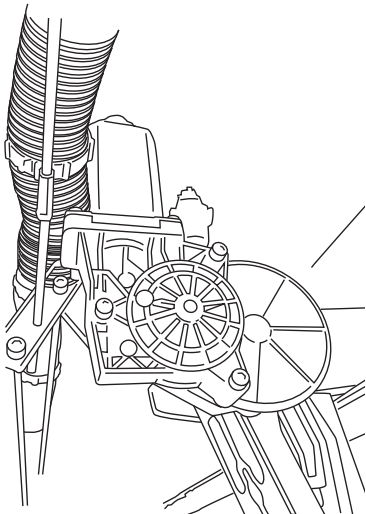

8

Torque bolts on mounting brackets to 16ft-lbs.

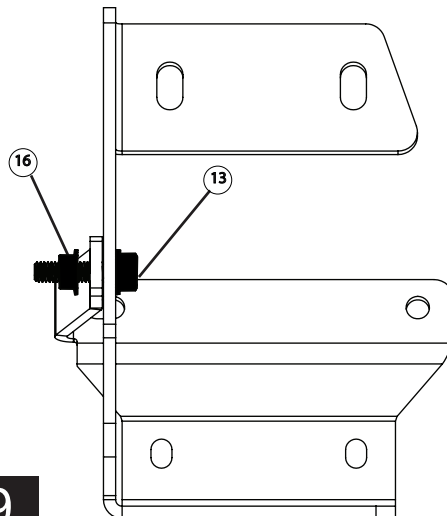

9

AMP RESEARCH POWERSTEP™ – FORD F150

Attach wire harness to controller (make sure connector locking tabs fully engage). Mount controller with the two 11" tie wraps to factory conduit, just forward of battery.

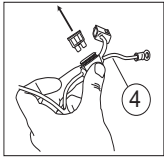

Remove fuse from wire harness

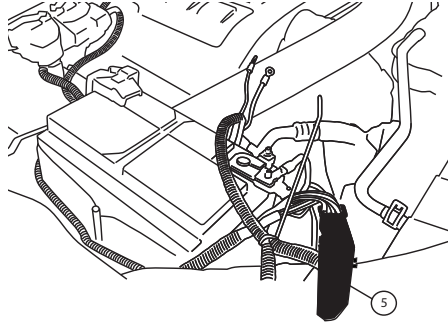

10

Connect red and black power leads to battery. Red lead goes to positive. Route shorter leg of harness down passenger-side wheel well and longer leg of harness down along driver side wheel well. Secure with tie wraps.

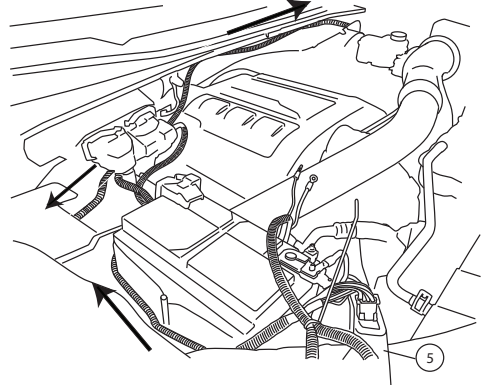

11

Remove driver side front kick panel and door sill plate. Roll back carpet to access hole for passing trigger wires into cab of vehicle.

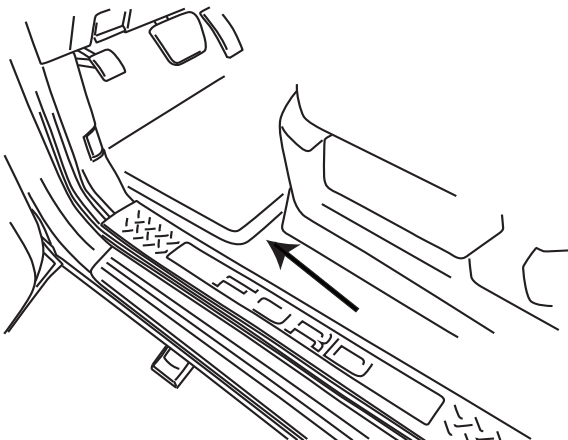

12

Remove grommet in floor panel above front linkage on driver side. Poke small hole into grommet and thread the two trigger wires through and up into the cabin of vehicle. Seal grommet with silicone sealer.



13

Connect harness to motor. Secure harness with tie wraps.

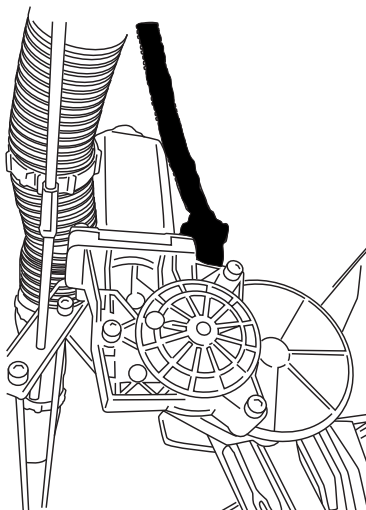

14

Affix LED lamp (20) to LED Bracket (22) as shown..

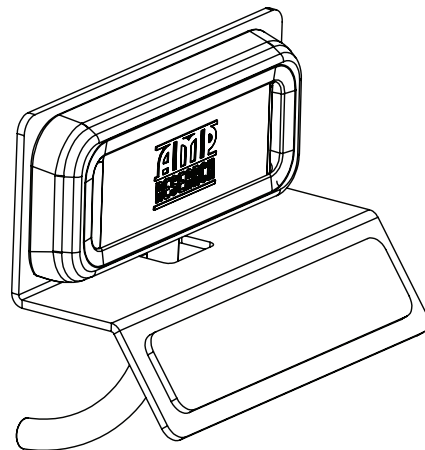

15

Affix LED light bracket assembly to rail. Mount front light rearward of front linkage and mount rear light just forward of rear linkage.

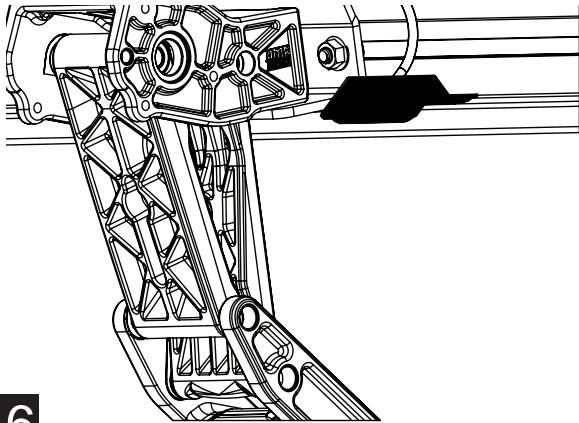

16

Using supplied butt connectors, connect the lamp wires. Red to Red, Black to Black. Once Crimped use heat gun to shrink tube. Close and wrap conduit with electrical tape. Secure all loose wires with cable ties. Pull lamp wires upward to avoid any wire snagging.

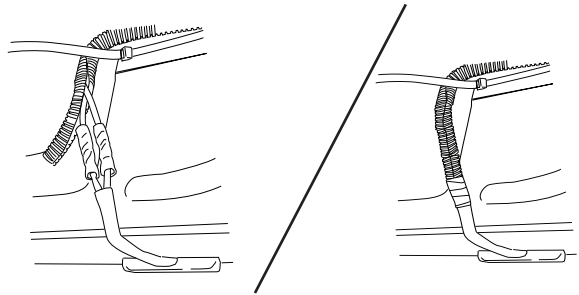

17

OBD II install: Use Supplied Posi Twist connectors to attach the Plug and Play Module to the Harness. Attach matching colors on the harness to the wires on the module. Plug in module to OBD II port on the vehicle. Secure harness with supplied tie wraps.

Note: If the OBD II pass thru harness (76404-01A) was purchased see install sheet supplied in packaging. The pass through harness allows for an open port for other accessories. See next page for a brief description.

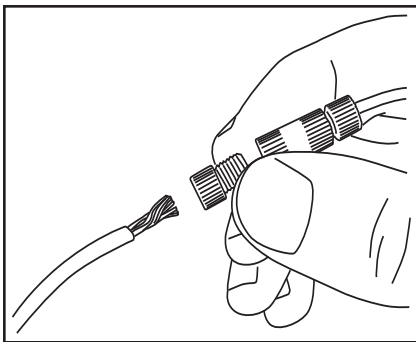

OBD II Connector located below steering column.

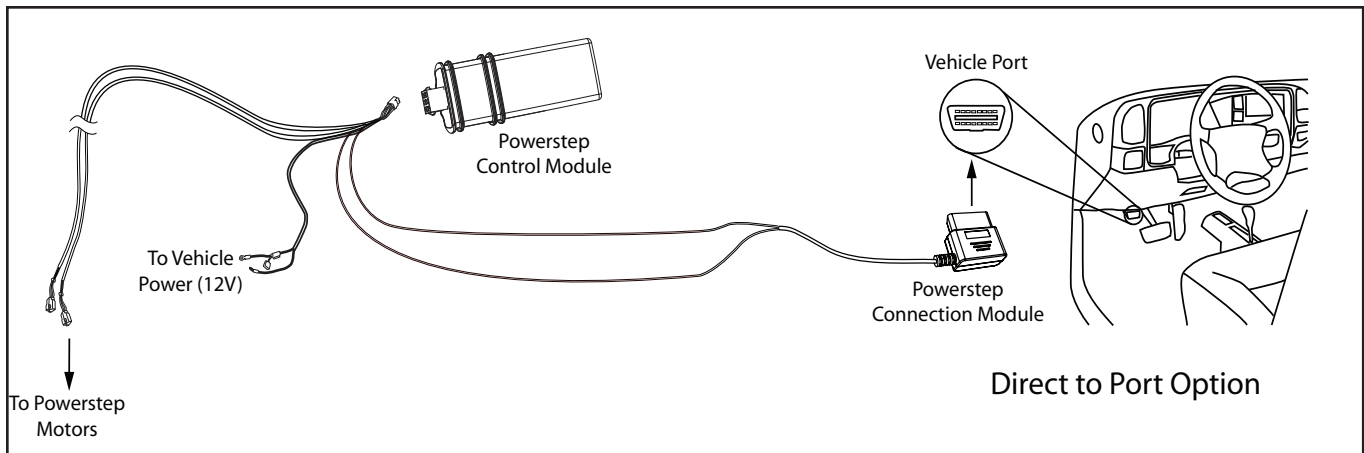
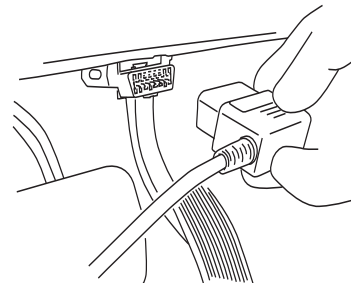

18

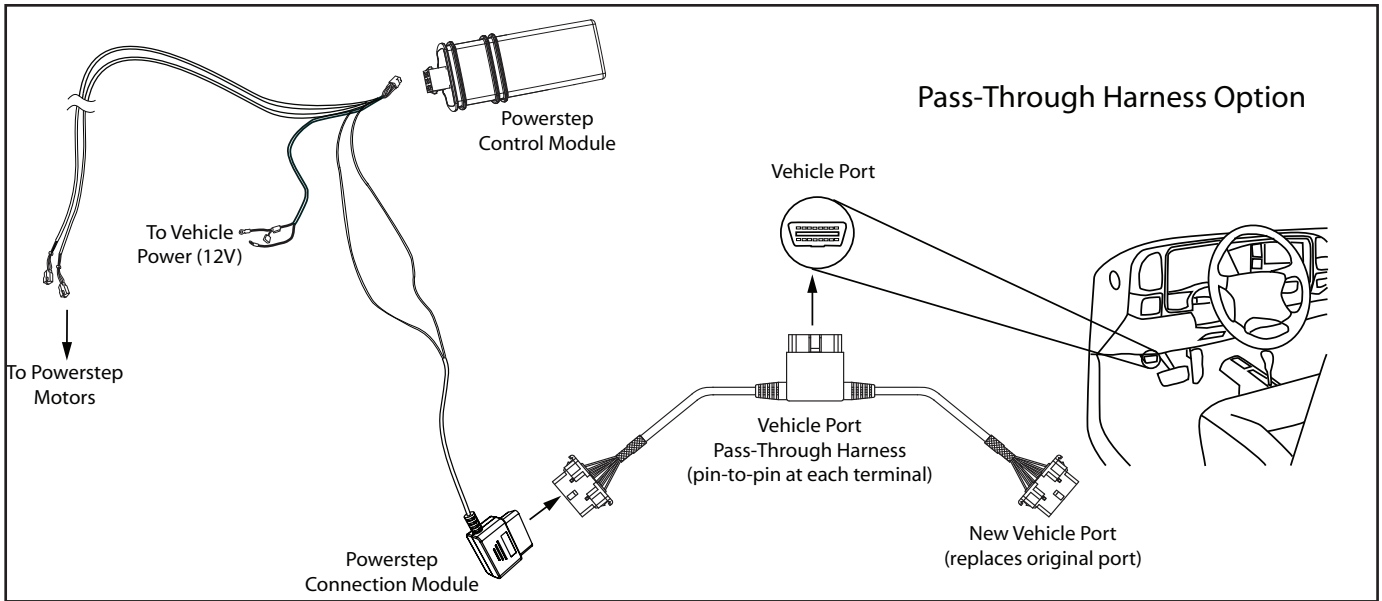

Check that all doors activate the Power Step and the LED Lights work when doors open and close. Reinstall any remaining trim panels.

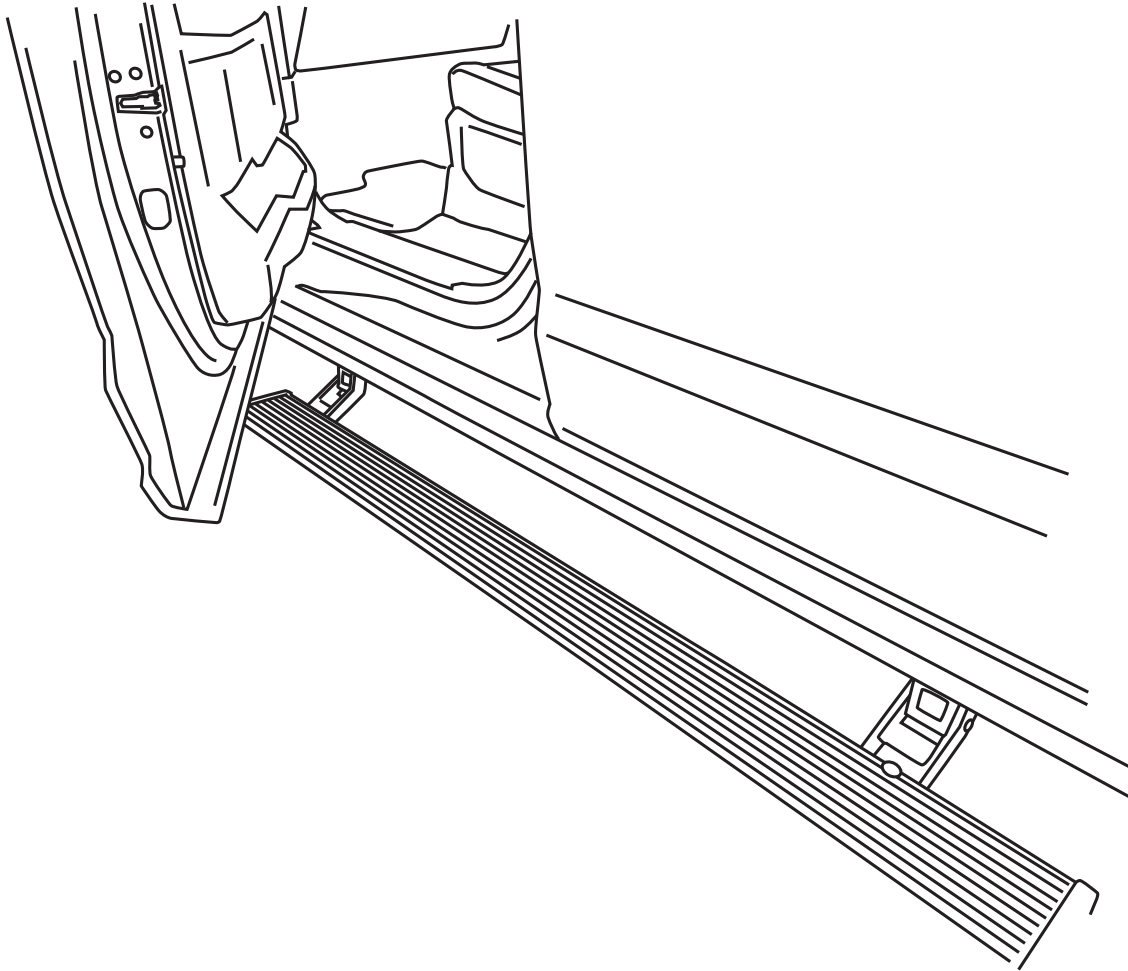

FINAL SYSTEM CHECK

Check that all doors activate the PowerStep and the LED lights work when doors open and close.

NORMAL OPERATION: When the doors open, PowerStep automatically deploys from under the vehicle.

When the doors are closed, PowerStep will automatically return to the stowed/retracted position. **Note that there is a 2-second delay before the PowerStep returns to the stowed/retracted position.**

CORRECT OPERATION OF LIGHTS: All four lamps will illuminate upon opening any door of vehicle. Lamps will stay on until restowing of both Power Steps or until 5 minutes has expired with the doors open. When the lights timeout after 5 minutes, they can be reilluminated by closing and opening any door of vehicle.



PowerStep™

Congratulations on your purchase of the genuine AMP Research PowerStep! Here's what you should know...

POWER-DEPLOYABLE RUNNING BOARDS OPERATION: AMP Research PowerStep running boards automatically move when the doors are opened to assist entering and exiting the vehicle.



Automatic power deploy:

The running boards will extend down and out when the doors are opened.

Automatic power stow:

The running boards will return to the stowed position when the doors are closed. There will be a 2-second delay before the running boards move to the stowed position.

Automatic stop:

If an object is in the way of the moving running board, the running board will automatically stop. To reset, clear any obstruction, then simply open and close the door to resume normal operation.



Manually set in the deployed (OUT) position for access to the roof:

The running boards can be manually set in the deployed position by firmly holding the step down with your foot while at the same time closing the door. To resume normal operation, open and close the door.

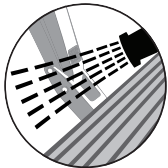

Maintenance: In adverse conditions, debris such as mud, dirt, and salt may become trapped in the running board mechanism, possibly leading to unwanted noise. If this occurs, manually set the running boards to the deployed position and flush the front and rear hinge arms with a high-pressure car wash wand.

Avoid spraying the motors directly. After washing, apply silicone spray lubricant to the hinge pivot pins. Do not apply silicone, wax or protectants like Armor All® to the running board stepping surface.

Caution! Keep hands away when the running board is in motion.