

# INSTALLATION GUIDE

# **AMP** Power Step RESEARCH MADE IN USA

APPLICATION

AMP Part #

Pass Through Harness

76404-01A

(Works with the following applications: 76127-01A, 76134-01A, 76141-01A, 76147-01A, 76151-01A, 76154-01A )

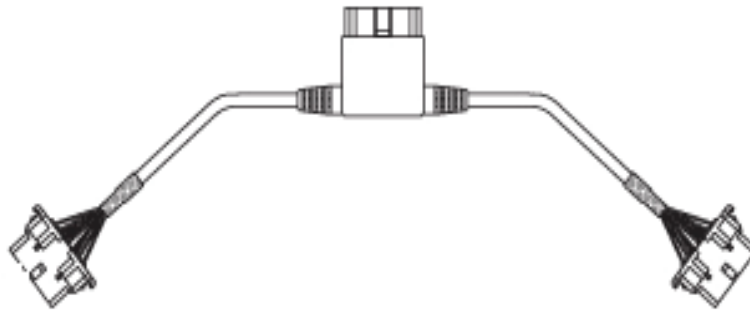

1

19-03972-90  
Pass Through  
Wire harness

Pass-Through Harness Option

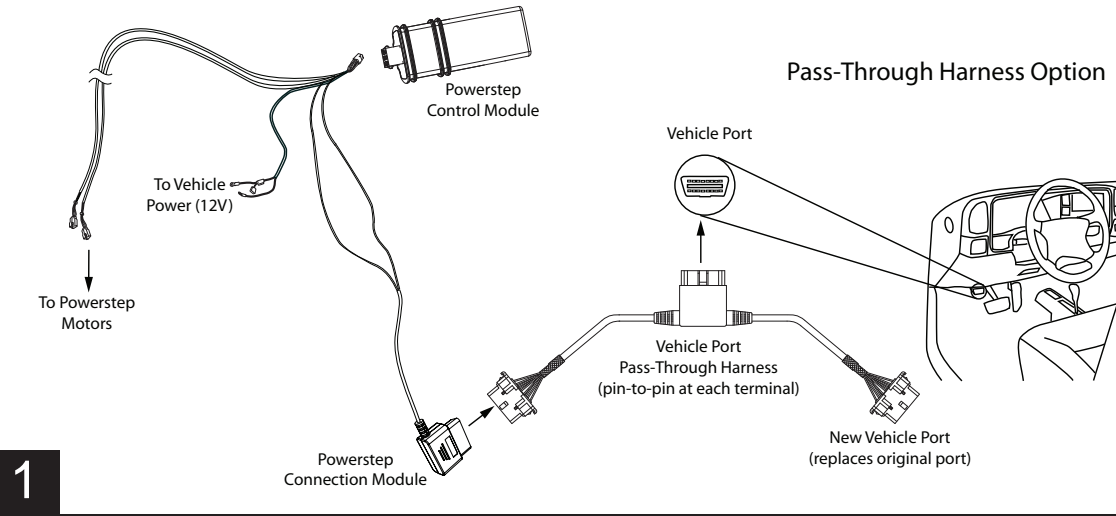

1

Locate OBD II Port located on underside of dash and remove two 6mm screws holding it in place.

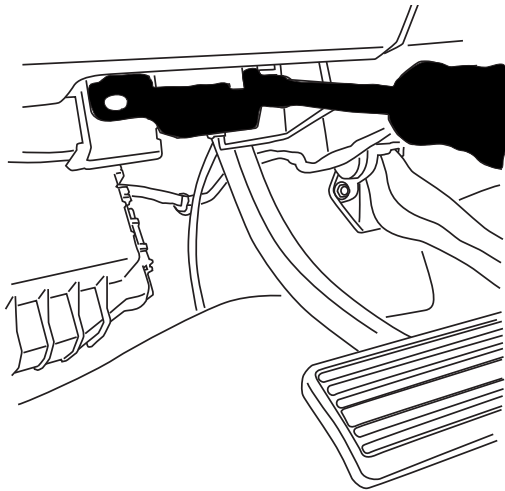

2

1. Plug harness into vehicle port. 2. Reinstall open port with 2 screws removed from step 2.  
3. Plug in powerstep module and use tie wraps to pull harness up and out of the way.

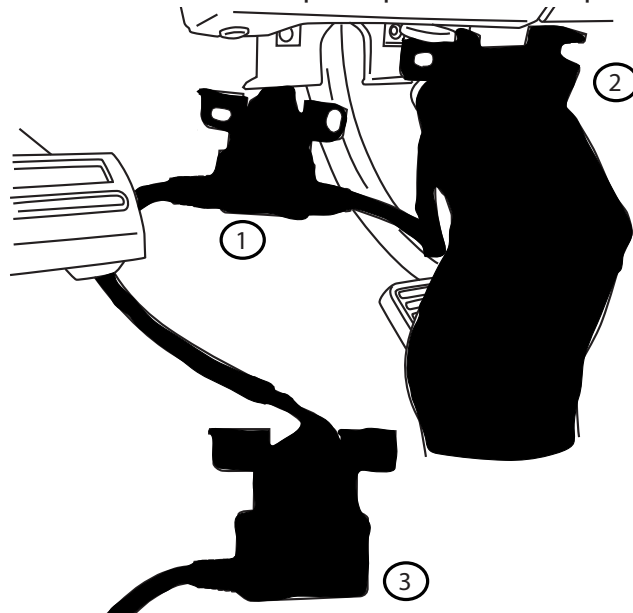

4

**POWER-DEPLOYABLE RUNNING BOARDS OPERATION:** AMP Research PowerStep running boards automatically move when the doors are opened to assist entering and exiting the vehicle.



**Automatic power deploy:**

The running boards will extend down and out when the doors are opened.

**Automatic power stow:**

The running boards will return to the stowed position when the doors are closed. There will be a 2-second delay before the running boards move to the stowed position.

**Automatic stop:**

If an object is in the way of the moving running board, the running board will automatically stop. To reset, clear any obstruction, then simply open and close the door to resume normal operation.



**Manually set in the deployed (OUT) position for access to the roof:**

The running boards can be manually set in the deployed position by firmly holding the step down with your foot while at the same time closing the door. To resume normal operation, open and close the door.

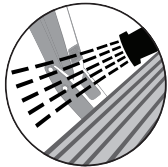

**Maintenance:** In adverse conditions, debris such as mud, dirt, and salt may become trapped in the running board mechanism, possibly leading to unwanted noise. If this occurs, manually set the running boards to the deployed position and flush the front and rear hinge arms with a high-pressure car wash wand.

Avoid spraying the motors directly. After washing, apply silicone spray lubricant to the hinge pivot pins. Do not apply silicone, wax or protectants like Armor All® to the running board stepping surface.

**Caution!** Keep hands away when the running board is in motion.

**WARNING**

Be sure to read and precisely follow the provided instructions when installing this product. Failure to do so could place the vehicle occupants in a potentially dangerous situation. After installing or reinstalling, re-check to insure that the product is properly installed.