

# INSTALLATION GUIDE



**PowerStep**  
MADE IN USA

**SMART  
SERIES**



TM

APPLICATION	LENGTH	MODEL YR	PART #
Ford F150 SuperCab	75"	2021	86152-01A
Ford F150 SuperCrew	85"	2021	86152-01A

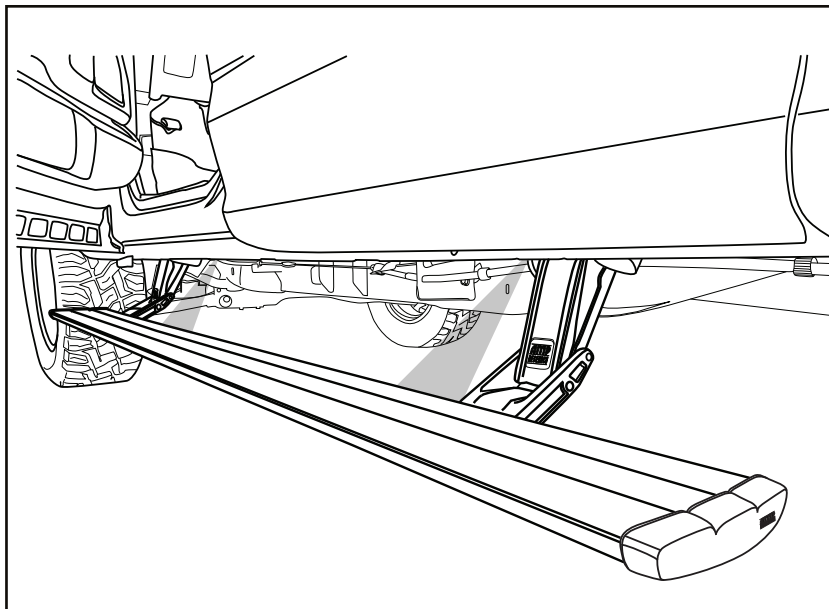

## INSTALLATION TIME

**2-3 Hours**

Professional installation recommended

## SKILL LEVEL



4= Experienced

## TOOLS REQUIRED

- Safety goggles
- 10 mm socket
- 13 mm socket
- 13 mm end wrench
- Ratchet wrench and extension
- Wire stripper
- 9/32" & 19/64" Drill Bit
- 3/16" hex key wrench ( allen wrench)
- 4mm hex key wrench ( allen wrench)
- Electrical tape
- Weather proof caulking (silicone sealer)

## INSTALLATION GUIDE

### Attaching motor to linkage assembly

The motors must be attached to the linkage assemblies before continuing the installation process.

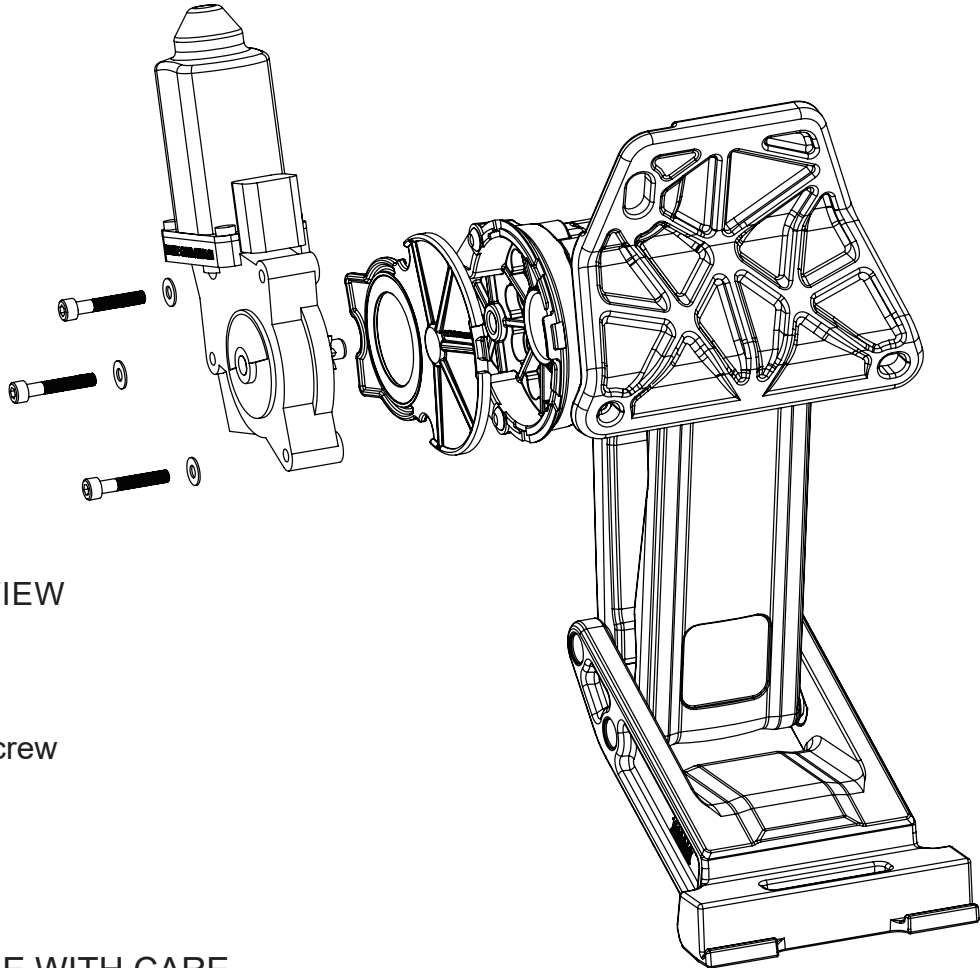

#### EXPLODED VIEW

- Motor
- Socket cap screw
- Washer

#### CAUTION: HANDLE WITH CARE.

To insure our customers receive all components with full integrity, we pack the motors separate from their linkage assemblies. This requires that the installer position and fasten the motor before continuing with the install. Please follow the instructions below and handle the assembly carefully.

**CAUTION:** Dropping the assembly or any excessive impact MAY cause damage to the motor.

#### Instructions:

1. Position the gear cover in place as shown if not already in place.
2. Seat motor into position on the three mounting bosses. This may require an adjustment of the gear by moving the swing arms.
3. After seating into place, fasten the motor with the three motor mount screws with 4mm allen wrench. Tighten screws to 36 in-lbs (4N-m). Do not over torque.

**Note: Some Applications require modification.**

**Application**

**Cut Length**

Super Cab  
Super Crew

75" (Trim 10")  
85" (No Modification Required)

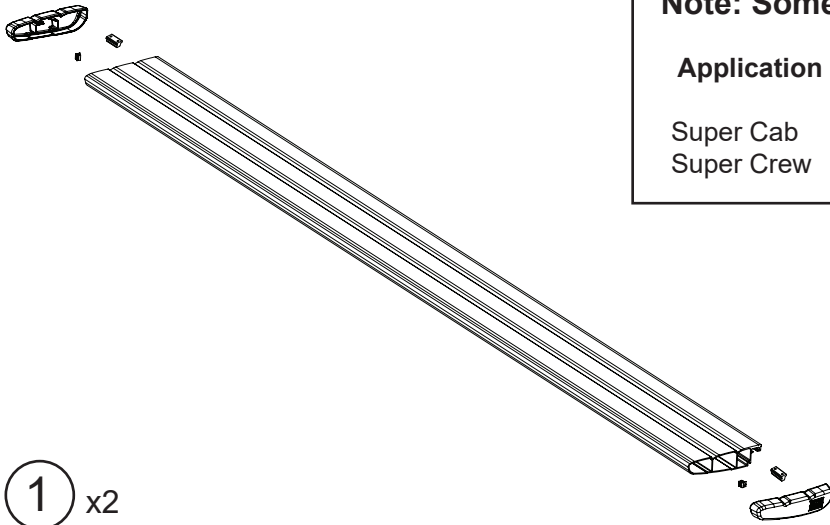

① x2

Running board assembly

- (A) End cap left (x1)
- (B) End cap right (x1)
- (C) T-nut insert (x2)
- (D) (S) Style clips (x2)

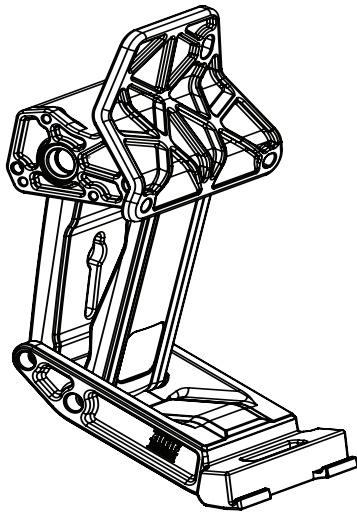

② x2

Idler linkage assembly

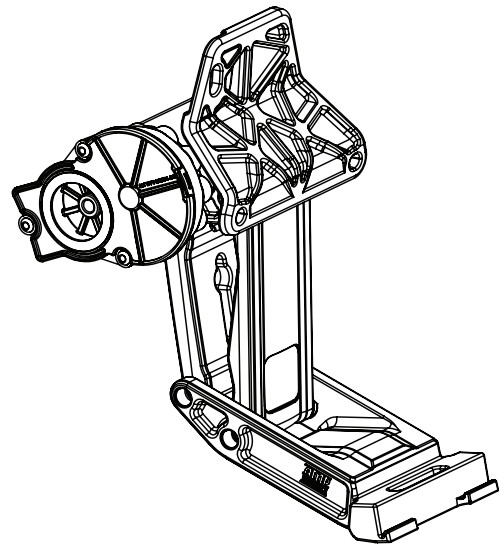

③ x2

Motor linkage assembly

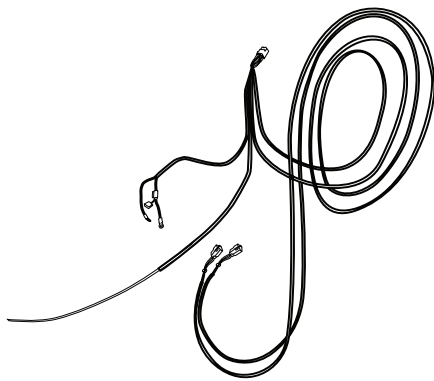

④

Wire harness

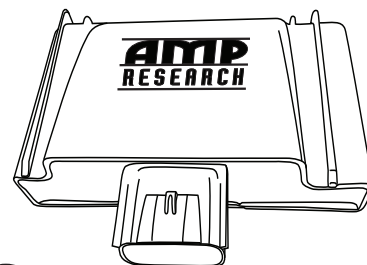

⑤

Controller SSA

PARTS LIST AND  
HARDWARE  
IDENTIFICATION



6  
Posi-Lock™ (Grey)

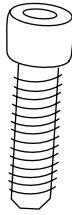

7 x8  
Socket cap screw

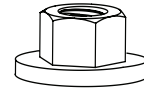

8 x12  
Nut with Conical Washer



9  
Grommet (Only needed  
on SuperCab)

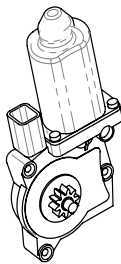

10 x2  
Motor

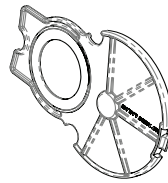

11 x2  
Gear Cover

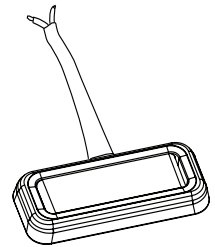

12 x4  
LED Light



13 x4  
Grommet

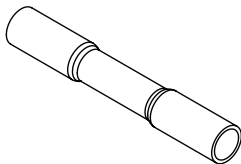

14 x8  
Butt Connector

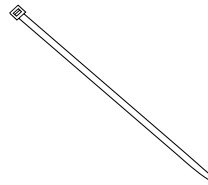

15 x20  
Cable Ties 7"

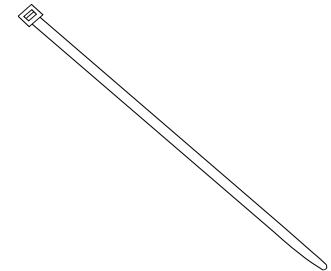

16 x2  
Cable Ties 11"

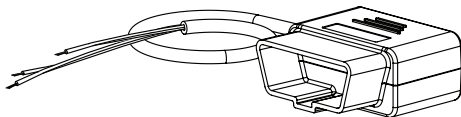

17  
ODB II Plug FD21 (smart series)



18  
Posi-Taps™ (Red/Black)



19 x2  
(S) Style Clip (Only used  
when trimming board length)

Locate mounting points; first and last set of studs on the inner sill.  
 Motor Linkage mounts toward the front of the truck and Idler mount toward the rear.  
 Driver side shown below.

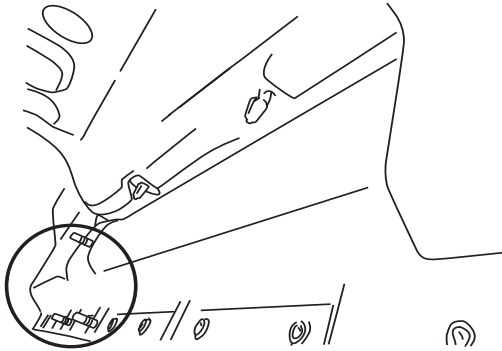

**1** Driver Side Rear Stud Location

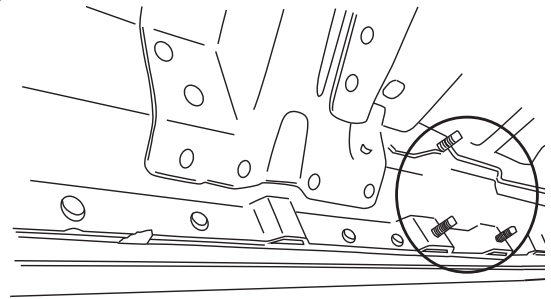

Driver Side Front Stud Location

Mount drive and Idler linkage assemblies. Repeat for passenger side. Make sure linkages sit square, fully resting on studs before tightening. Torque to 16 ft. lbs (22N·m)

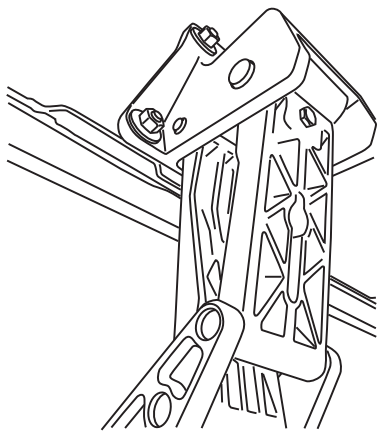

**2** Idler Linkage (Rear)

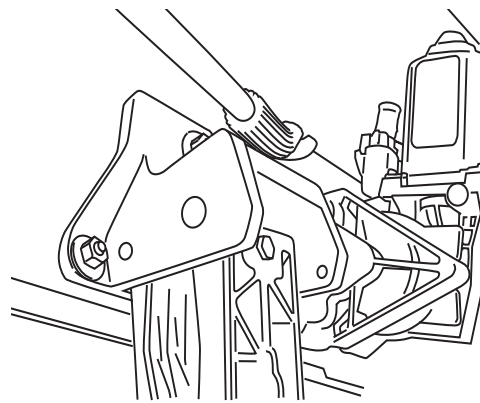

Drive Linkage (Front)

Remove fuse from wire harness

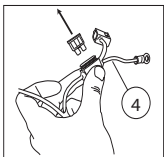

Connect red power lead to battery. Connect black ground lead to 13mm bolt outside of fender wall. Attach wire harness to controller (make sure the connector locking tabs fully engage). Mount controller with the two 11" tie wraps to factory conduit, just forward of battery.

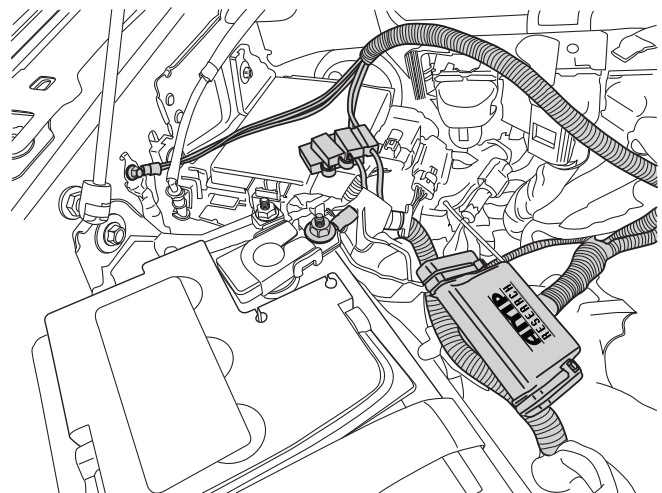

**3**

Route shorter leg of harness down passenger-side wheel well and longer leg of harness down along driver-side wheel well. Attach wire harness with supplied 7" cable ties (15).

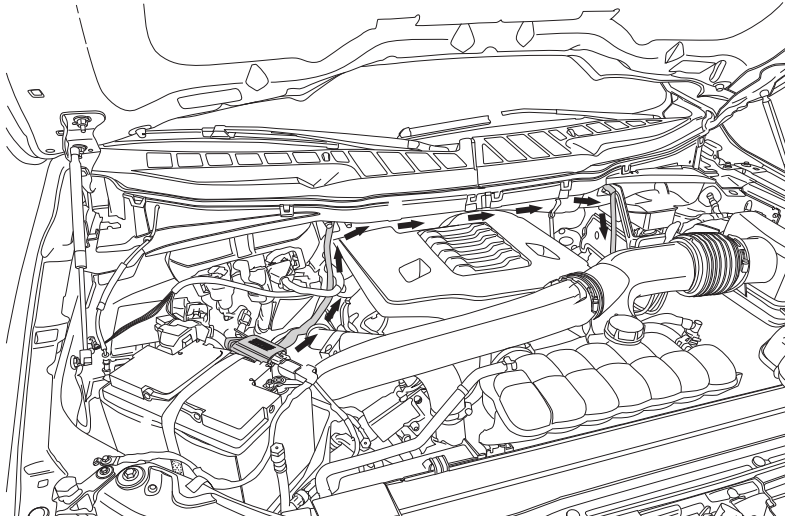

4

Route factory harness underneath vehicle and plug in motors (both sides). Route remaining LED light wires back towards rear of vehicle.

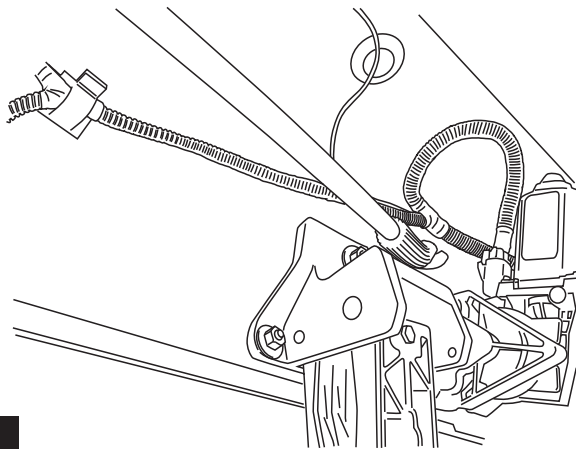

5

Remove driver side front kick panel and door sill plate. Roll back carpet to access hole for passing trigger wire into cab of vehicle.

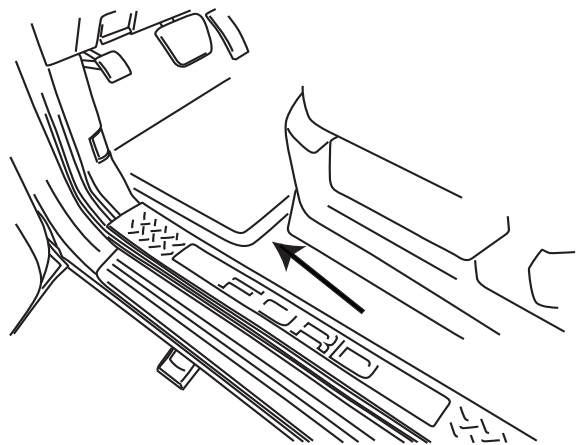

6

**On Supercrew models,** remove grommet in floor panel above front linkage on driver side. Poke small hole into grommet and thread the trigger wire through and up into the cabin of vehicle. Seal grommet with silicone sealer.

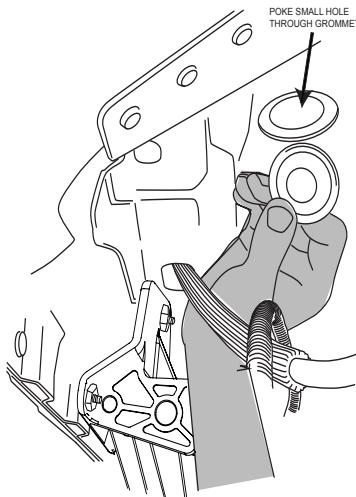

7

**On Super Cab models,** use a 9/32" drill bit to drill hole through floor and insert grommet (#9) that is supplied with kit. Thread the wire through and apply silicone sealant.

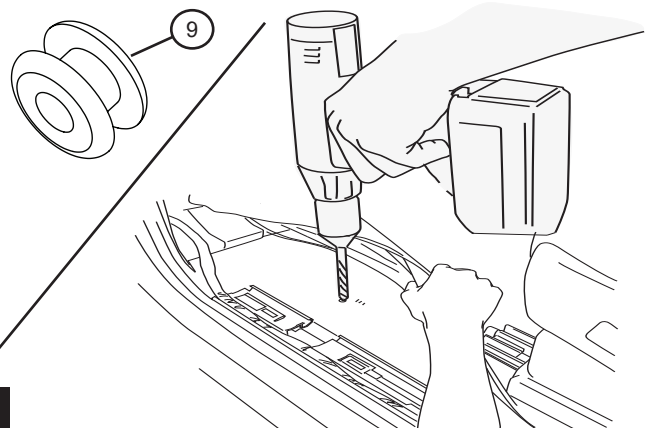

8

Locate black module just above e-brake pedal, and proceed to remove it for easier access. To remove module from bracket, push tab as shown and slide bracket downward.

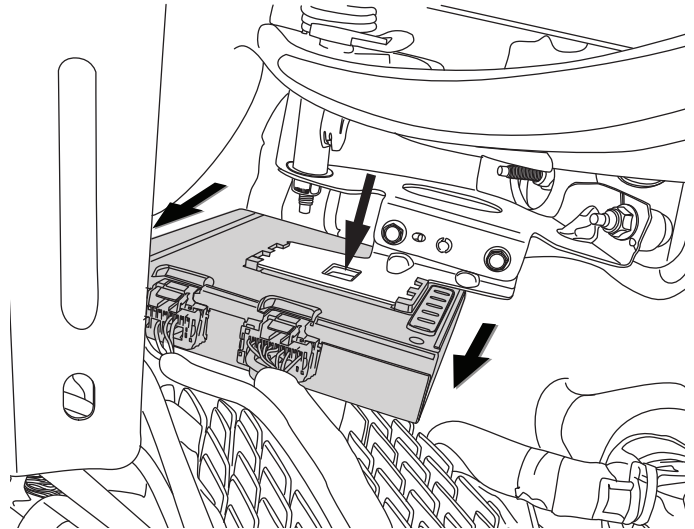

8

Locate the following wires and connect the blue and white wires of the Powerstep Connection module with supplied Posi-Tap™ to the following wire colors listed below.

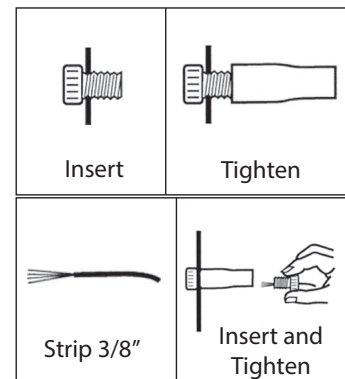
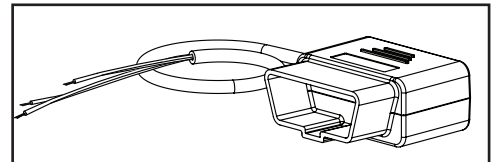
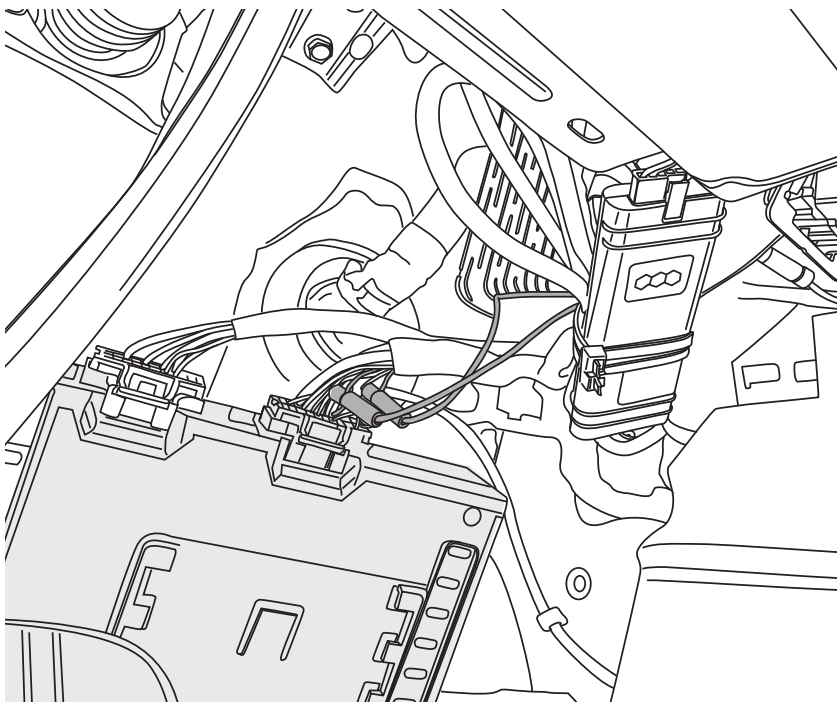

Factory Can Wire	Powerstep Connection Module wire color
Green w/blue stripe	White
White w/green stripe	Blue

After connecting wires, slide module back on to bracket, and ensure locking tab engages.

9

**OBD II connection:** Use Supplied Posi-Lock™ connector to attach the Powerstep Connection Module to the Harness. Plug in Powerstep Connection module to OBD II port on the vehicle. Secure harness with supplied tie wraps. *Note: If the OBD II pass thru harness (76404-01A) was purchased see install sheet supplied in packaging. The pass through harness allows for an open port for other accessories. See below for a brief description.*

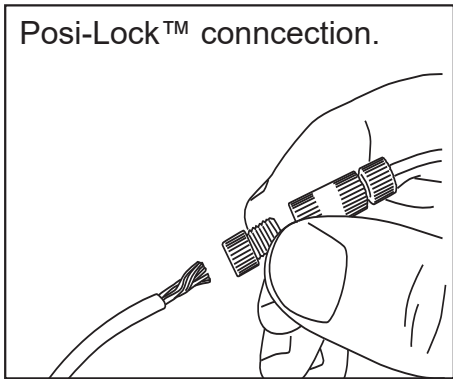
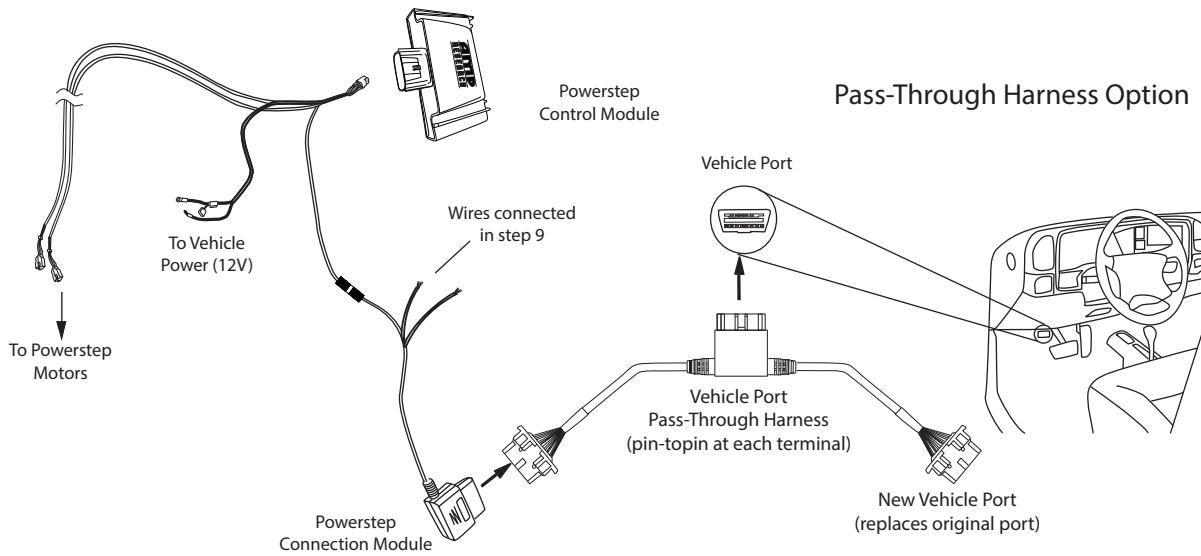
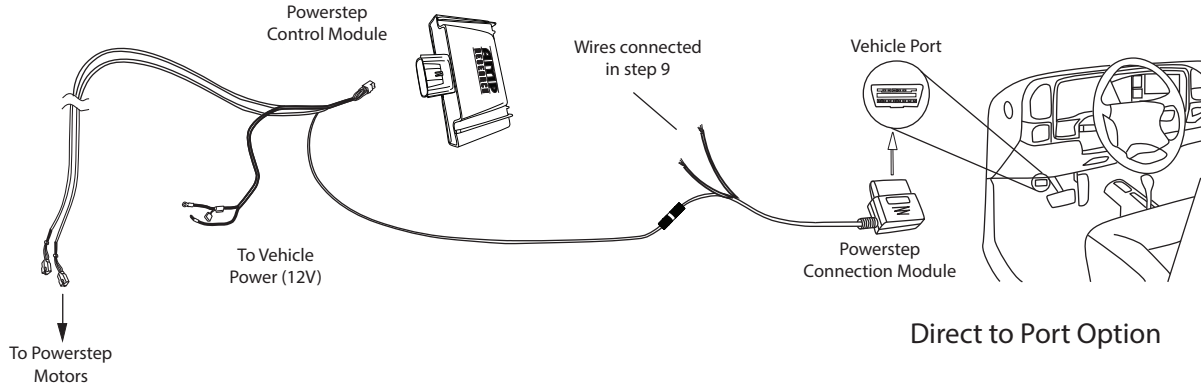

OBD II Module located below steering column.

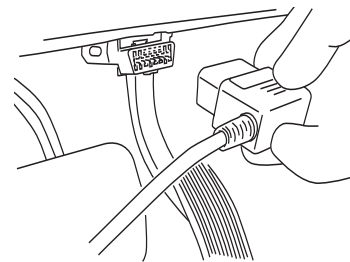



Attach step, sliding the mounting T-nut into position. Torque to 10 ft lbs (13.5 Nm)

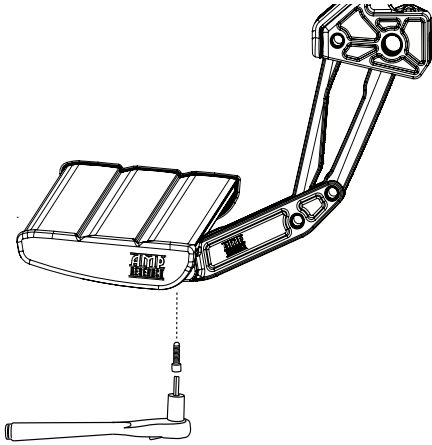

On each side of the vehicle measure from the rear linkage to end of the board. Measurement should be approximately 11" as shown below.

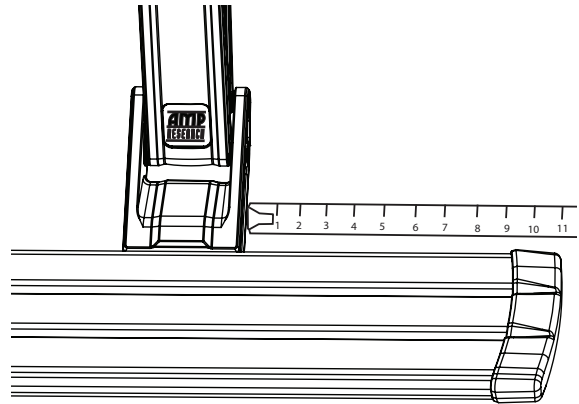

12

13

On each side of the vehicle use tape to mark the led drill location two sections from studs as shown below. Use tape to indicate. Locations are approximately 23" & 66" from front door edge.

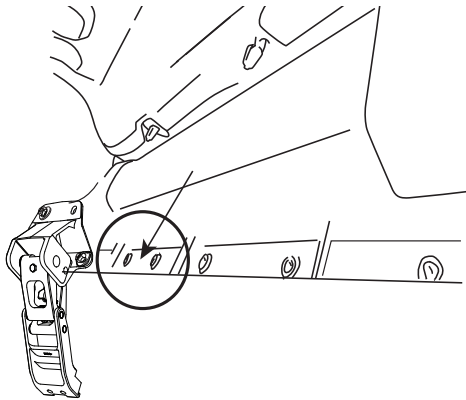

**Drive Side Rear Mounted**

(In between two rivets just forward of mounting location, as shown above)

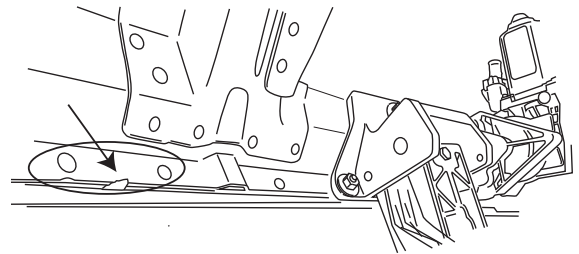

**Drive Side Front Mounted**

(Just under left edge of body-brace, as shown above)

14

Mark hole location 1/2" midpoint of the rocker with tape and center punch and drill 19/64" hole into pinch weld. Deburr hole and insert grommet (#13) for LED Wire.

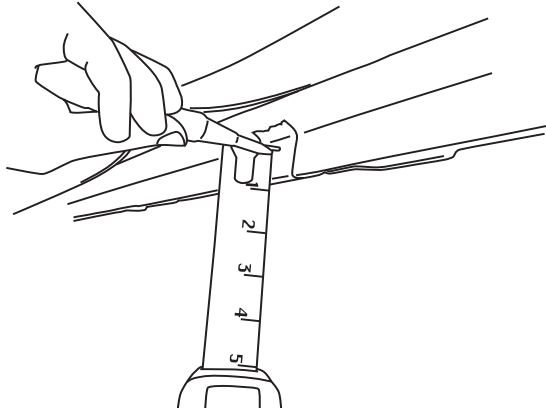

Route LED wires through through grommet, clean surface, and stick on to rocker panel as shown below.

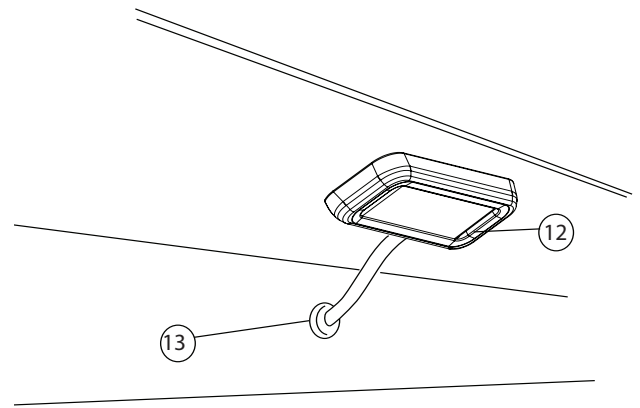

15

16

Using supplied butt connectors, connect the lamp wires. Red to Red, Black to Black. Heat the shrink tubing on the connectors to seal wires.

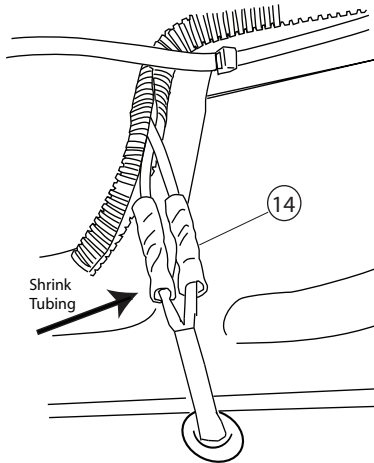

Close and wrap with conduit and electrical tape. Secure all loose wires with cable ties with lamp wires pulled upward to avoid any wire snagging.

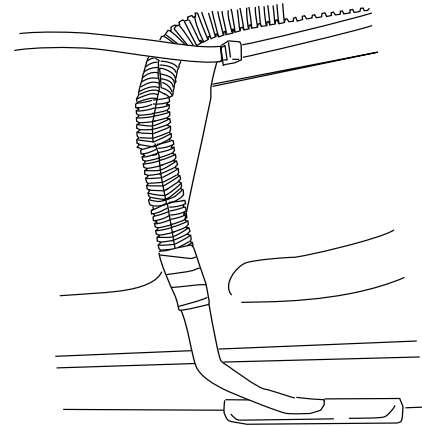

17

18

Reinstall fuse.

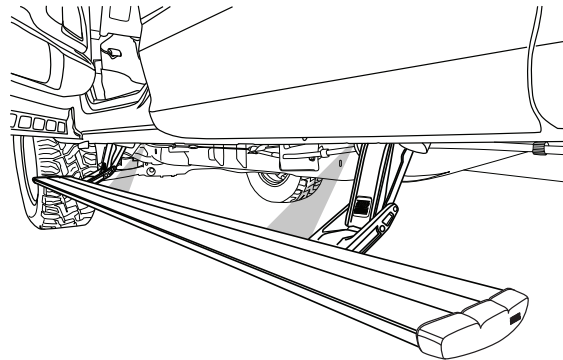
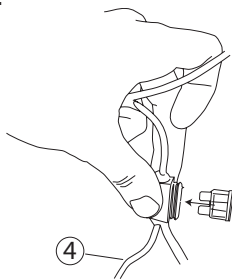

### FINAL SYSTEM CHECK

Check that all doors activate the PowerStep and the LED lights work when doors open and close.

**NORMAL OPERATION:** When the doors open, PowerStep automatically deploys from under the vehicle.

When the doors are closed, PowerStep will automatically return to the stowed/retracted position. **Note that there is a 2-second delay before the PowerStep returns to the stowed/retracted position.**

**CORRECT OPERATION OF LIGHTS:** All four lamps will illuminate upon opening any door of vehicle. Lamps will stay on until restowing of both Power Steps or until 5 minutes has expired with the doors open. When the lights timeout after 5 minutes, they can be reilluminated by closing and opening any door of vehicle.

19



**PowerStep** SMART SERIES  
MADE IN USA

Congratulations on your purchase of the genuine AMP Research PowerStep! Here's what you should know...

**POWER-DEPLOYABLE RUNNING BOARDS OPERATION:** AMP Research PowerStep running boards automatically move when the doors are opened to assist entering and exiting the vehicle.

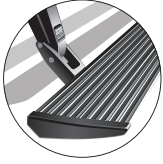

**Automatic power deploy:**

The running boards will extend down and out when the doors are opened.

**Automatic power stow:**

The running boards will return to the stowed position when the doors are closed. There will be a 2-second delay before the running boards move to the stowed position.

**Automatic stop:**

If an object is in the way of the moving running board, the running board will automatically stop. To reset, clear any obstruction, then simply open and close the door to resume normal operation.



**Manual over-ride:**

Use Power Step app to manually set in the deployed (OUT) position for access to the roof. The steps can be manually set in the retracted (IN) position as well.

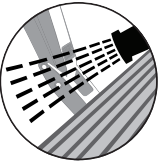

**Maintenance:** In adverse conditions, debris such as mud, dirt, and salt may become trapped in the running board mechanism, possibly leading to unwanted noise. If this occurs, manually set the running boards to the deployed position and flush the front and rear hinge arms with a high-pressure car wash wand.

Avoid spraying the motors directly. After washing, apply silicone spray lubricant to the hinge pivot pins. Do not apply silicone, wax or protectants like Armor All® to the running board stepping surface.

**Caution!** Keep hands away when the running board is in motion.

**WARNING**

Be sure to read and precisely follow the provided instructions when installing this product. Failure to do so could place the vehicle occupants in a potentially dangerous situation. After installing or reinstalling, re-check to insure that the product is properly installed.



The material that your product is made from can be recycled. Please also consider recycling the packaging that your product came in.



Discover other running boards and step bars on our website.