

INSTALLATION GUIDE

AMP Research Power Step

MADE IN USA

APPLICATION

AMP Part #

Override Switch
(To be used on all powersteps except 75134-01A & 75141-01A)

79105-01A

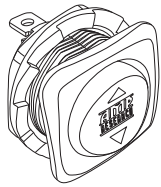

1
Override Switch

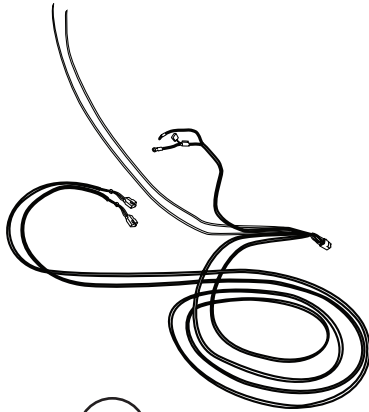

2
Harness

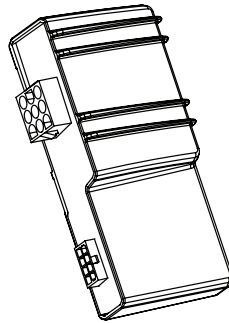

3
Controller

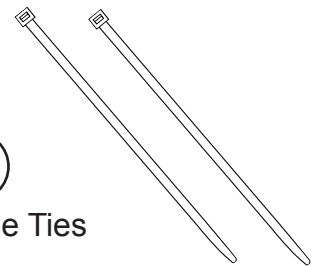

4
Cable Ties

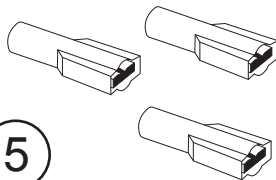

5
Connectors

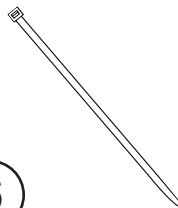

6
Cable Ties (x10)

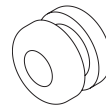

7
Grommet

TOOLS REQUIRED

- cordless drill
- 13/16", 9/32" & 1/8" drill
- Wire crimpers
- Wire stripper/cutter

Invented, engineered and manufactured exclusively by AMP Research in the USA. May be covered by one of the following patents: 6,641,158; 6,830,257; 6,834,875; 6,938,909; 7,055,839; 7,380,807; 7,398,985; 7,584,975 ©2012 AMP Research. All rights reserved.

AMP RESEARCH POWERSTEP™ – OVERRIDE SWITCH

Plug 9 pin and 8 pin connector onto controller. Make sure locking tabs fully engage.

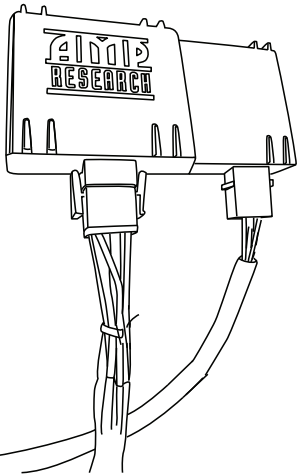

1

Mount controller with the two tie wraps provided. . Route override switch harness across firewall and into the cab of vehicle. A grommet is provided if needed/ Use 9/32 drill for grommet.

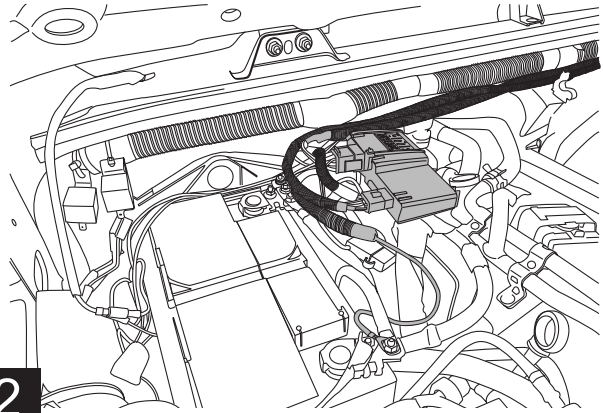

2

Depending on vehicle configuration select desired switch location on dash. Before drilling hole check behind panels for obstructions. **Note: Wires may be present behind dash panels.**

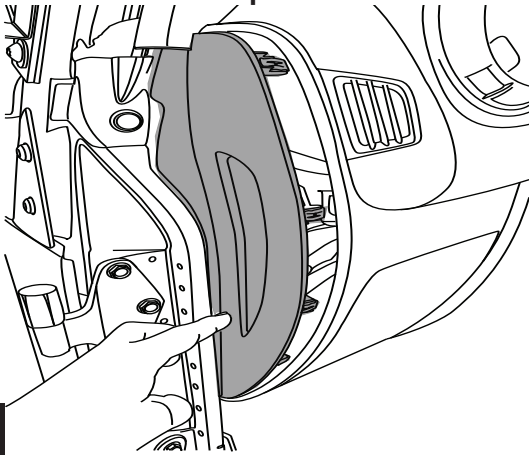

3

Once switch position is selected, mark and drill out mounting hole. Pre drill using 1/8" drill bit. Final drill size will be 13/16". **We recommend using a step drill!**

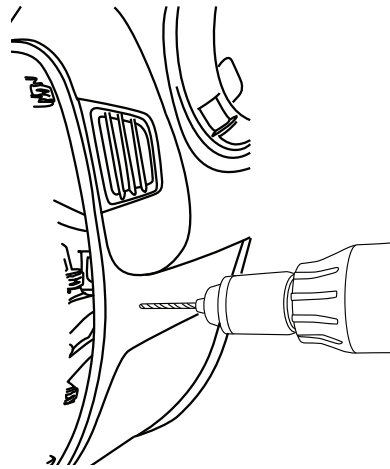

4

Once Hole is drilled and switch wires are pulled into vehicle crimp supplied connectors onto the 3 wires.

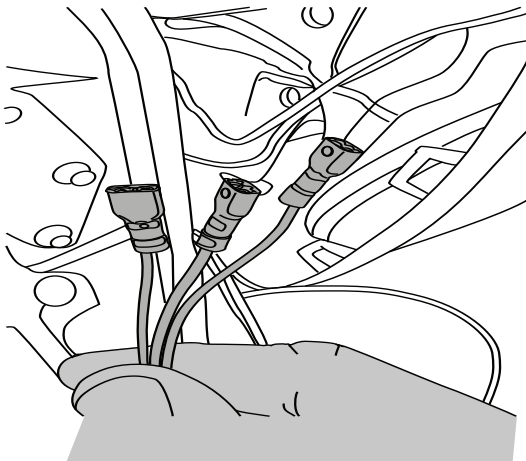

5

Mount switch in drilled hole and tighten nut on switch. Slide terminals with wire colors shown below

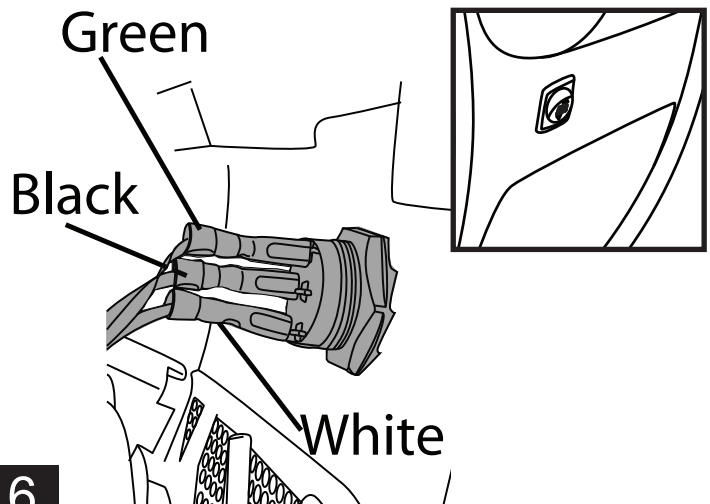

6

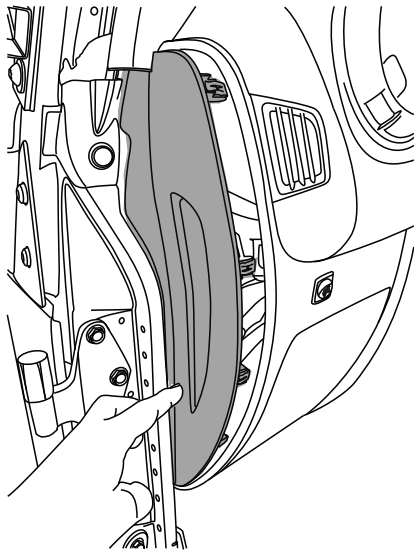

Reinstall all trim panels that were removed to install switch onto dash.

7

Installation complete. Verify switch operates properly.

Toggle Up: Running Boards Retract and remain in the Stowed Position

Neutral / Auto: Running Boards in Auto position operate with doors opened and closed.

Toggle Down: Running Boards Deploy and remain in Deployed Position

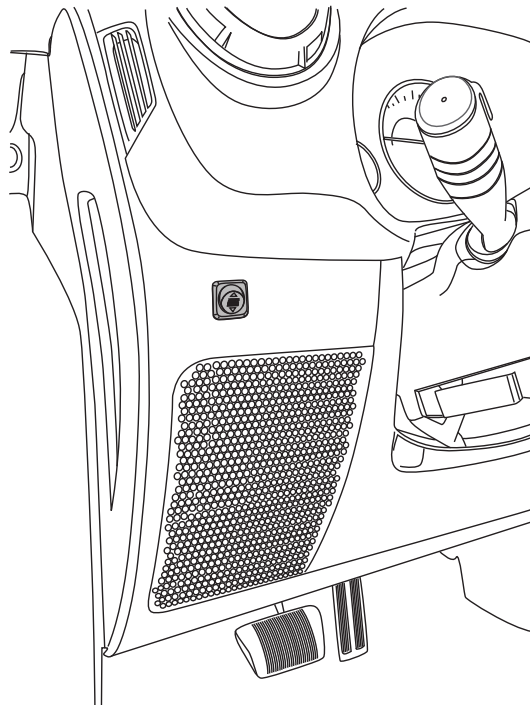

Note: Running Boards will return to Auto Operation in the next door cycle after 30 minutes.

8

POWER-DEPLOYABLE RUNNING BOARDS OPERATION: AMP Research PowerStep running boards automatically move when the doors are opened to assist entering and exiting the vehicle.



Automatic power deploy:

The running boards will extend down and out when the doors are opened.

Automatic power stow:

The running boards will return to the stowed position when the doors are closed. There will be a 2-second delay before the running boards move to the stowed position.

Automatic stop:

If an object is in the way of the moving running board, the running board will automatically stop. To reset, clear any obstruction, then simply open and close the door to resume normal operation.



Manually set in the deployed (OUT) position for access to the roof:

The running boards can be manually set in the deployed position by firmly holding the step down with your foot while at the same time closing the door. To resume normal operation, open and close the door.

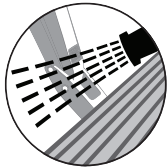

Maintenance: In adverse conditions, debris such as mud, dirt, and salt may become trapped in the running board mechanism, possibly leading to unwanted noise. If this occurs, manually set the running boards to the deployed position and flush the front and rear hinge arms with a high-pressure car wash wand.

Avoid spraying the motors directly. After washing, apply silicone spray lubricant to the hinge pivot pins. Do not apply silicone, wax or protectants like Armor All® to the running board stepping surface.

Caution! Keep hands away when the running board is in motion.