

Installation Instructions

PowerStep™ Xtreme

MADE IN USA

APPLICATION

AMP Part

Chevrolet Silverado1500 / GMC Sierra 1500 - Double Cab *	2014-18	78154-01A
Chevrolet Silverado1500 / GMC Sierra 1500- Crew Cab	2014-18	78154-01A
Chevrolet Silverado HD / GMC Sierra HD - Double Cab * (excludes diesel engine)	2015-18	78154-01A
Chevrolet Silverado HD / GMC Sierra HD- Crew Cab (excludes diesel engine)	2015-18	78154-01A

* Modification required to running board assembly. See Item 1 on page 3.

INSTALLATION TIME

2-3 Hours

Professional installation recommended

SKILL LEVEL



4= Experienced

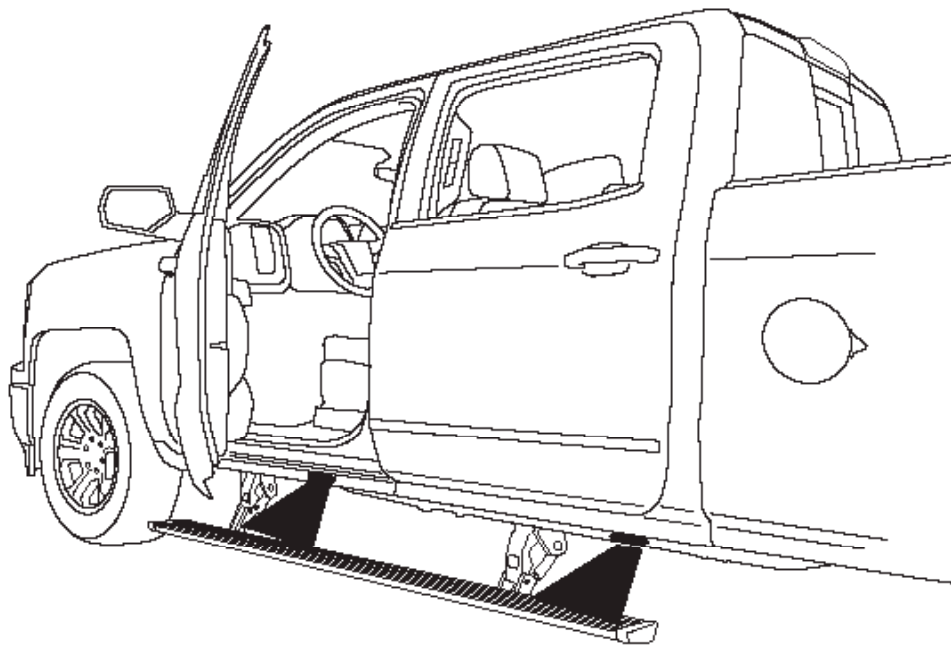

TOOLS REQUIRED

- Safety goggles
- Measuring tape
- Flat blade screwdriver
- Power Drill
- 9/32" drill bit
- 13 mm socket
- Ratchet wrench and extension
- 13mm end wrench
- Wire crimpers
- Wire stripper / cutter
- 3/16" hex key wrench (allen wrench)
- 4mm hex key wrench (allen wrench)
- Electrical tape
- Weather proof caulking (silicone sealer)
- Silicone spray

Invented, engineered and manufactured exclusively by AMP Research in the USA. May be covered by one of the following patents: 6,641,158; 6,830,257; 6,834,875; 6,938,909; 7,055,839; 7,380,807; 7,398,985; 7,584,975

INSTALLATION GUIDE

Attaching motor to Linkage assembly

The motors must be attached to the Linkage assemblies before continuing the installation process.

EXPLODED VIEW

- Motor
- Gear Cover
- Socket cap screw
- Washer

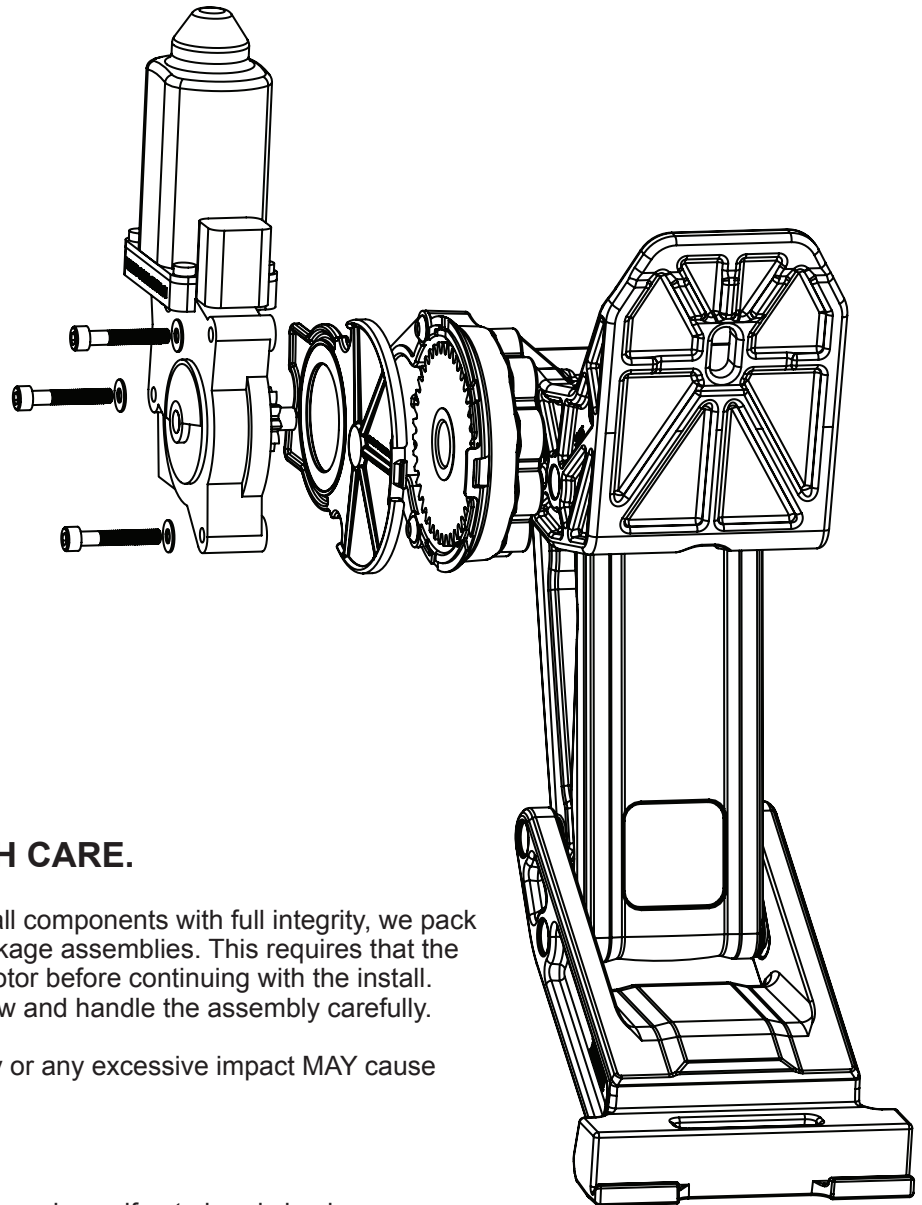

CAUTION: HANDLE WITH CARE.

To ensure our customers receive all components with full integrity, we pack the motors separate from their Linkage assemblies. This requires that the installer position and fasten the motor before continuing with the install. Please follow the instructions below and handle the assembly carefully.

CAUTION: Dropping the assembly or any excessive impact MAY cause damage to the motor.

Instructions:

1. Position the gear cover in place as shown if not already in place.
2. Seat motor into position on the three mounting bosses. This may require an adjustment of the gear by moving the swing arms.
3. After seating into place, fasten the motor with the three motor mount screws with 4mm Hex Head. Tighten screws to 36 in-lbs (4N-m). **Do not over torque.**

Note: Some Applications require modification.

Application	Cut Length
Crew Cab	79" (No Modification Required)
Extended Cab	72" (Trim 7")

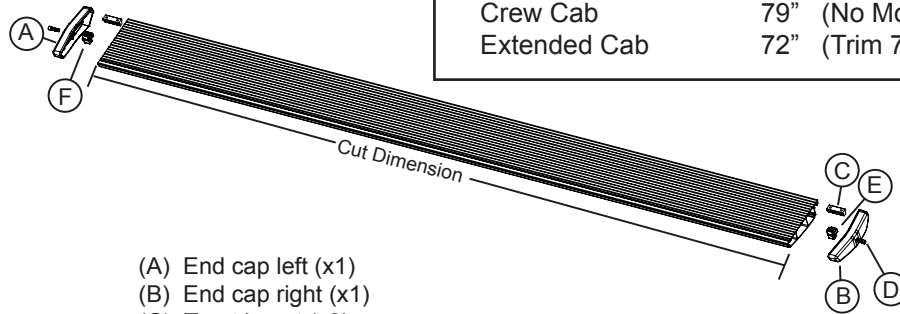

- (A) End cap left (x1)
- (B) End cap right (x1)
- (C) T-nut insert (x2)
- (D) Socket cap screw (x2)
- (E) End cap wedge right (x1)
- (F) End cap wedge left (x1)

1 x2
Running board assembly

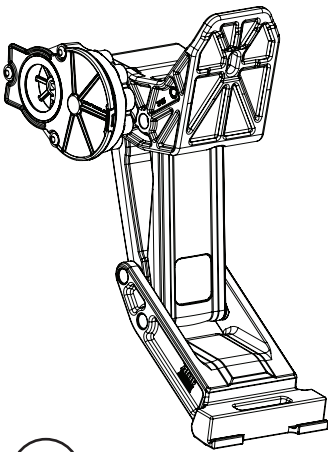

2 x4
Motor Linkage assembly

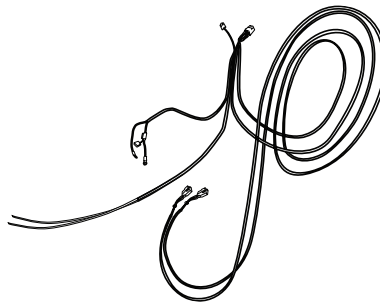

3
Wire harness

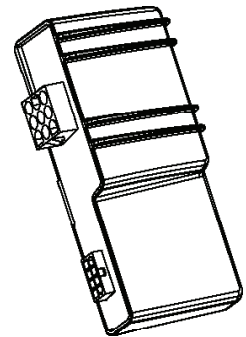

4
Controller

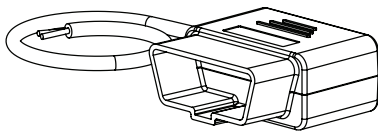

5
OBD II Plug

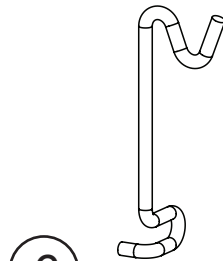

6
Brake Cable Bracket

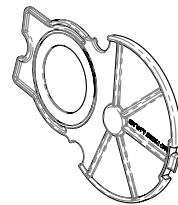

7 x4
Gear Cover

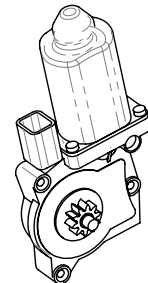

8 x4
Motor

AMP RESEARCH POWERSTEP™ – CHEVROLET / GMC

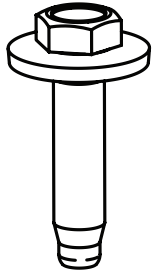

9 x4
Hex Bolt w
Conical washer

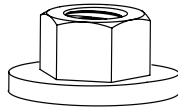

10 x4
Nut w Conical
washer

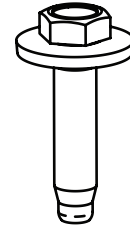

11 x5
Hex Bolt w
Conical washer

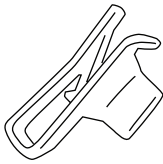

12 x4
U-nut

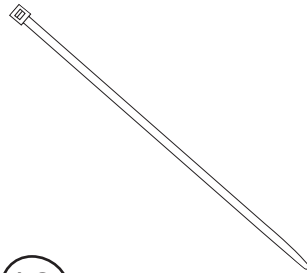

13 x20
Cable tie (7")

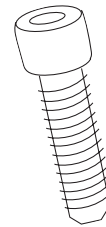

14 x8
Socket Cap Screw

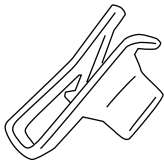

15
U Nut

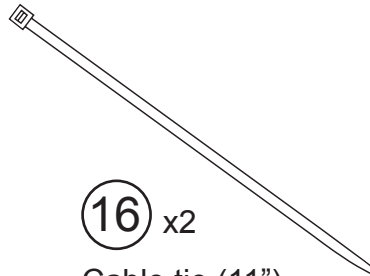

16 x2
Cable tie (11")

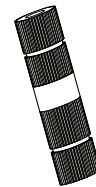

17 x2
Posi-Lock™

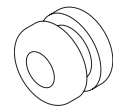

18
Grommet

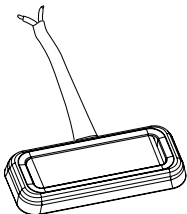

19 x4
LED Lamp

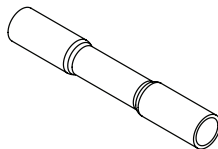

20 x8
Butt Connector

1500 Models Only!

Install U Nut (16) into position just forward of brake cable T junction. Use supplied bolt (12) to hold Brake cable rod into position.

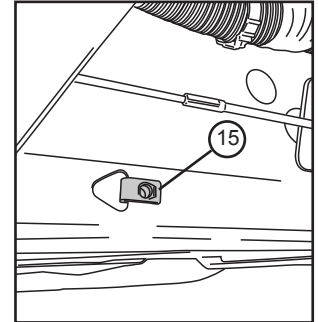
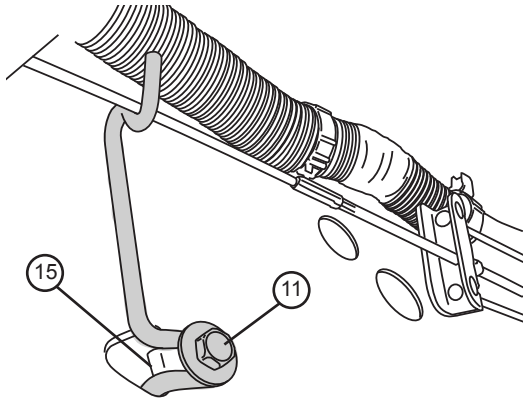

1

Front Drive Linkage: Thread supplied bolt (9) in about half way into the first sheetmetal tab / hole from front. Set linkage over bolt and Tighten lower bolt (9) to 16ft-lbs(22N m). Finger tighten nut (11) onto bolt (9). Install bolt (11) and torque to 16 ft-lb (22N m). Next torque lower nut (10) to 16 ft-lb (22N m) using wrench to hold lower bolt in place.

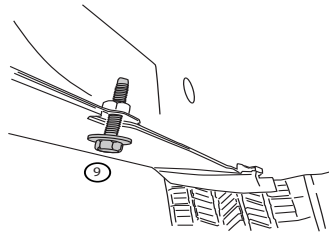

Note: Threaded nut may not be present on some vehicles. Bolt will assemble the same as step 3.

NOTE: U Nut may not be needed on some model trucks.

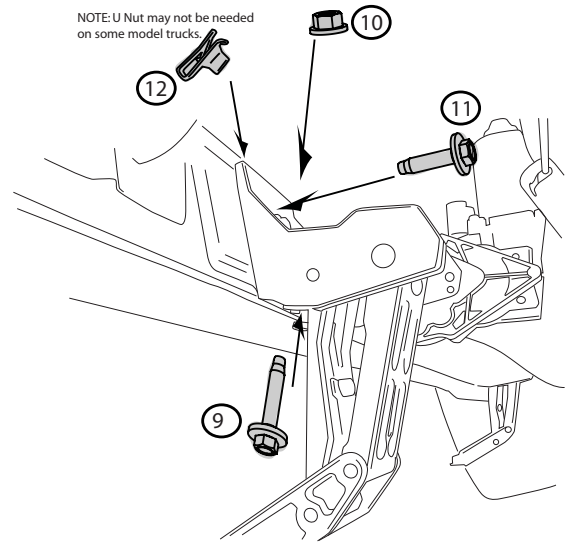

2

Rear Drive Linkage: Install driver side Motor Linkage in fourth sheetmetal tab / hole from front. Linkage will then clear parking brake cable.

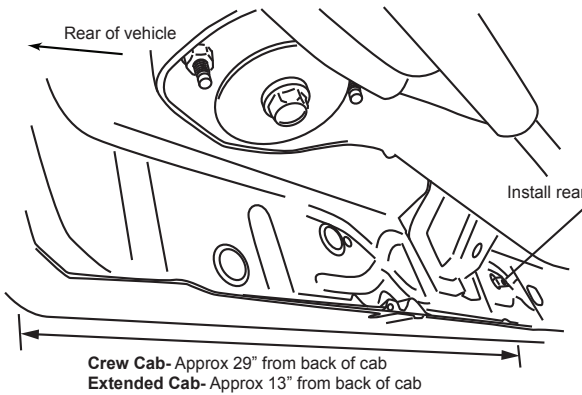

Note: U-nut may be needed if threaded insert is not present on vehicle

NOTE: U Nut may not be needed on some model trucks.

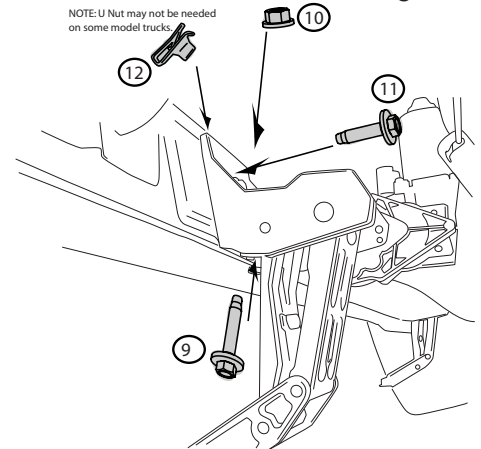

3

Set linkage into second to last sheetmetal tab / hole from rear. Use supplied bolt (9) and nut(10) to hold in position. Install bolt (11) into upper mounting hole and snug both bolts. Torque upper bolt (12) to 16ft-lbs(22N m) first and then torque lower bolt (9) and nut (10) to 16 ft-lb (22N m). Repeat linkage installation on Passenger side.

AMP RESEARCH POWERSTEP™ – CHEVROLET / GMC

Slide mounting T-nut into position, aligning the end of the board with the rear edge of the back door. Mount board and tighten fasteners to 10 ft-lbs. Insure linkages are squared to body prior to torquing fasteners.

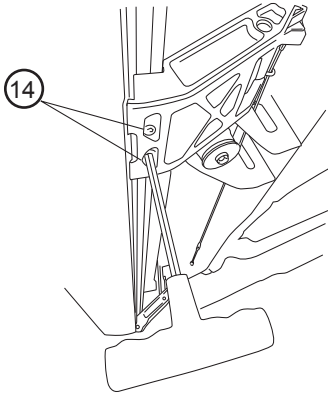

4

Using the two 11" cable ties, mount controller to support arm next to battery. Plug in harness (Ensure that locking tabs engage)

CAUTION:
Do not ground wrench when engaged with nut.

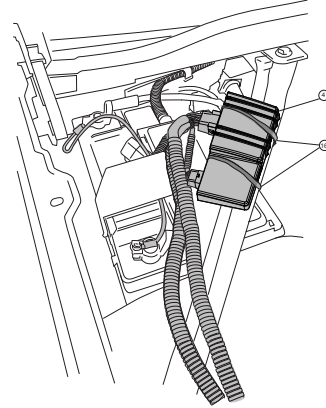

5

Remove power fuse. Attach power lead (RED wire) to positive pole on the battery. Attach ground lead to negative battery pole.

Route long end of wire harness above engine and down through drivers side wheel well. Zip tie harness to cowling clips on fire wall. Route short end down passengers side.

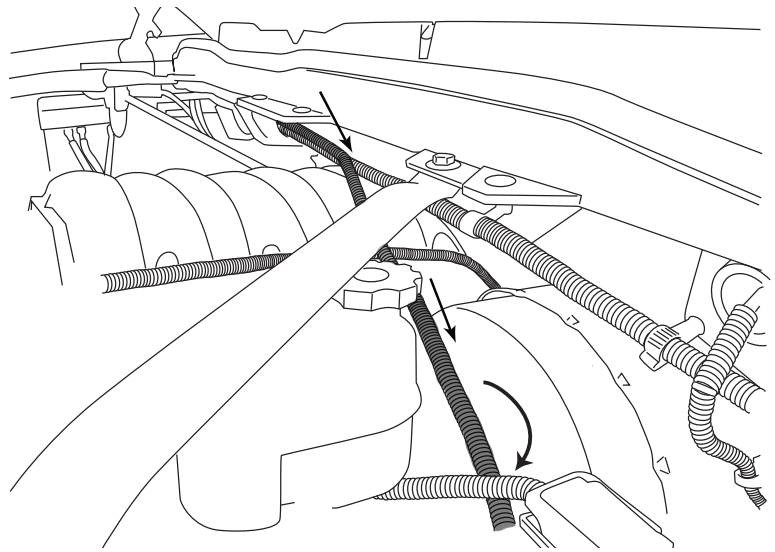

6

Pull up front door sill plate covers as shown.

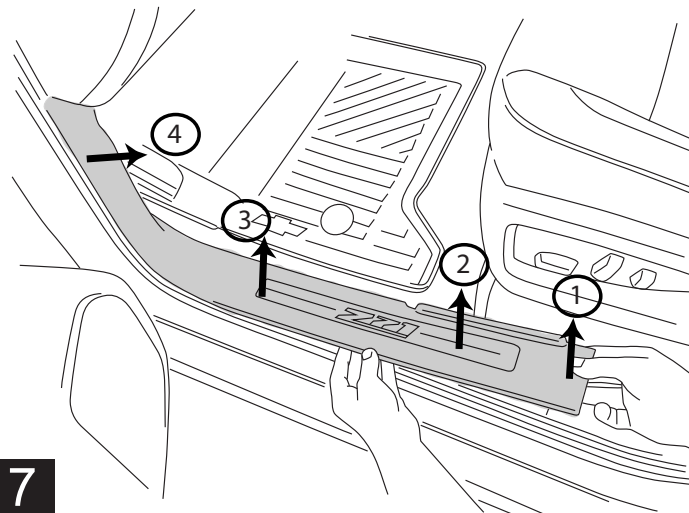

7

Pull up the carpet and drill 9/32" hole in metal and insert supplied rubber grommet (18).

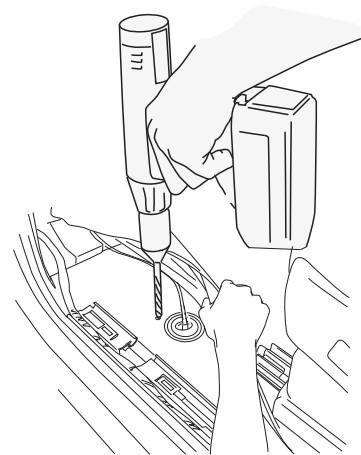

8

Route wire harness along the frame and back towards rear linkages. Secure with zip ties. Push both wires through rubber grommets.

NOTE: Seal holes with silicone glue and cover with tape so carpet does not stick to glue.

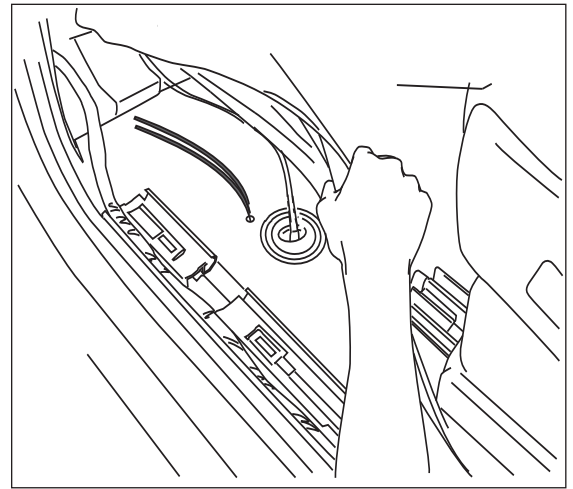
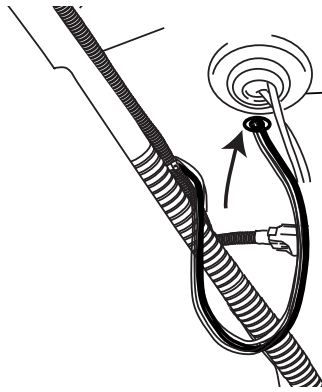

9

On each side of the vehicle measure from the front edge of door line on the pinch weld to the specified lengths below. Measure at 23" for front LED Light and 63" for rear LED Light.

Affix lamp to rocker panel surface. Make sure the lamp is affixed to a clean, flat surface. There is a step down midway across the surface. Affix lamp just outside of step down.

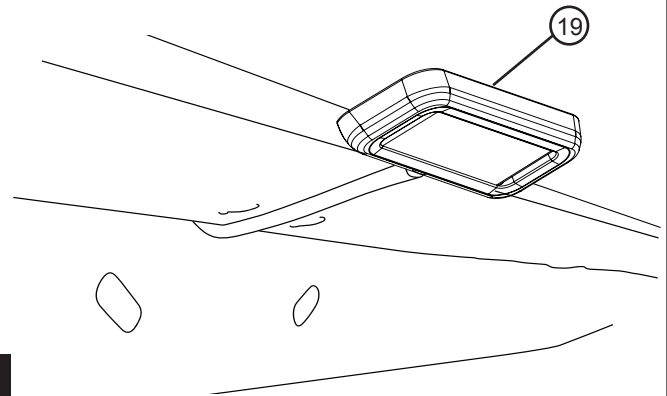
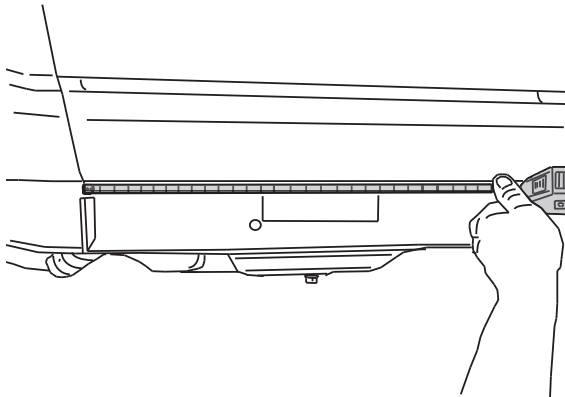

10

11

Using supplied butt connectors, connect the lamp wires. Red to Red, Black to Black. Once Crimped use heat gun to shrink tube. Close and wrap conduit with electrical tape. Secure all loose wires with cable ties. Pull lamp wires upward to avoid any wire snagging.

Connect harness to motor. Secure harness with tie wraps.

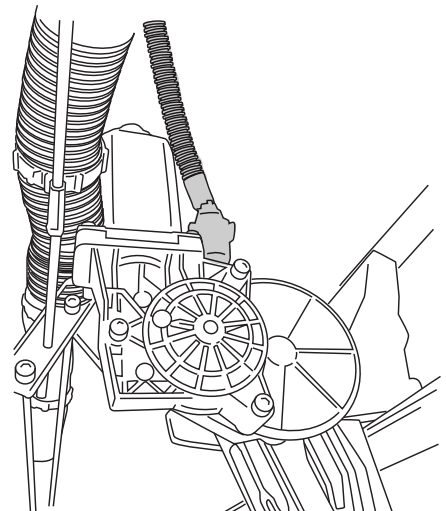
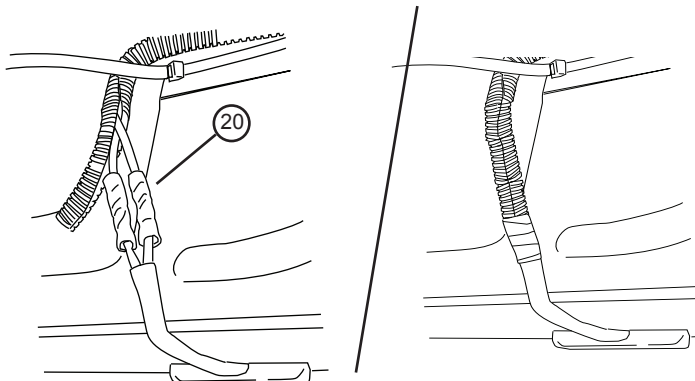

12

13

OBD II install: Use Supplied Posi Twist connectors to attach the Plug and Play Module to the Harness. Attach matching colors on the harness to the wires on the module. Plug in module to OBD II port on the vehicle. Secure harness with supplied tie wraps.

Note: If the OBD II pass thru harness (76404-01A) was purchased see install sheet supplied in packaging. The pass through harness allows for an open port for other accessories. See below for a brief description.

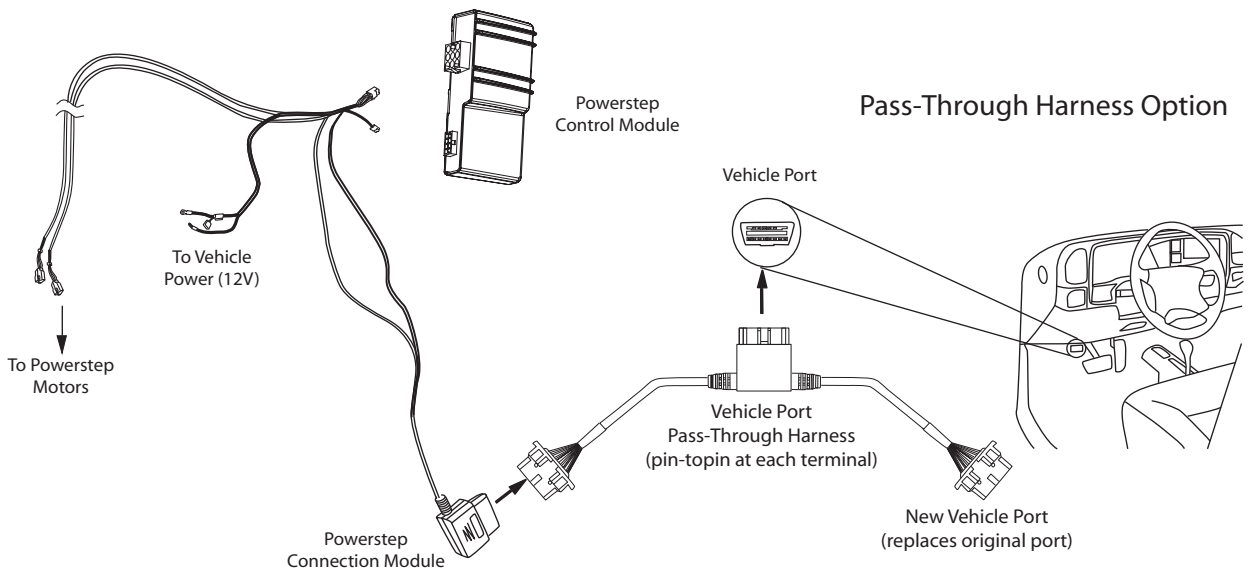
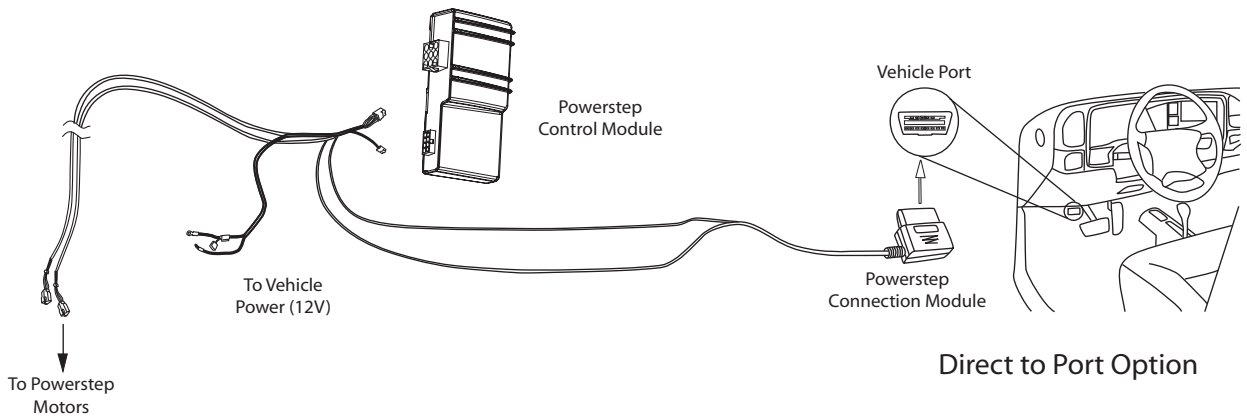
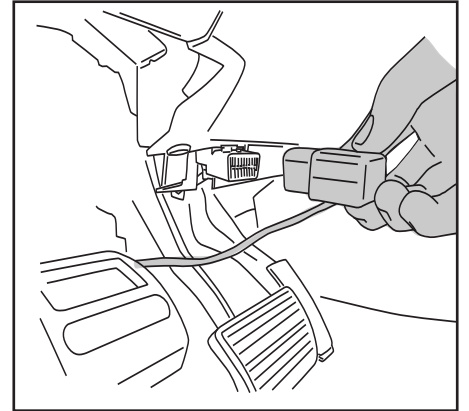
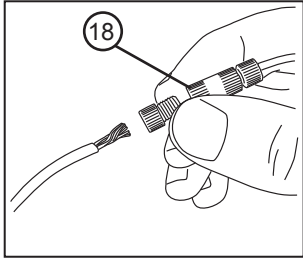

Reinstall fuse. Check that all doors activate the Power Step and the LED Lights work when doors open and close. Reinstall any remaining trim panels.

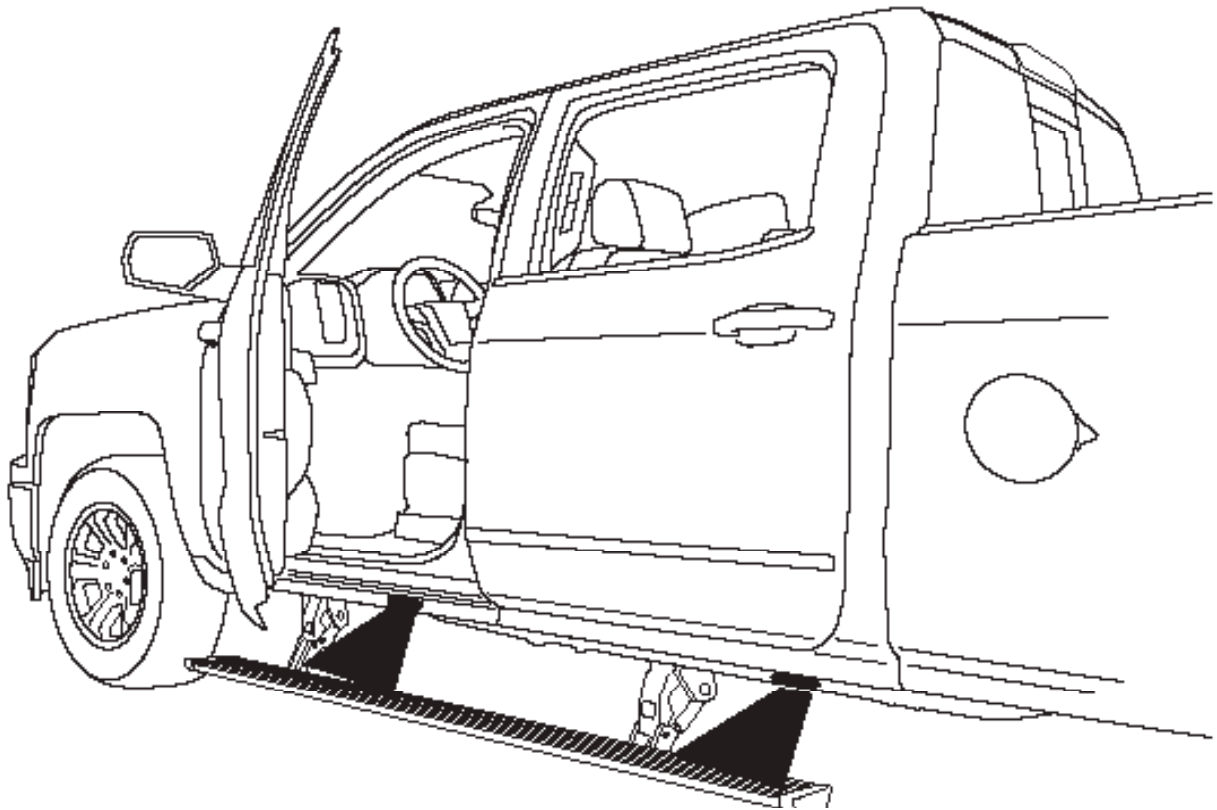
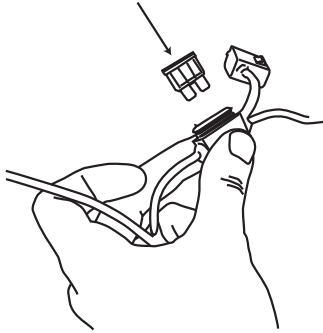

FINAL SYSTEM CHECK

Check that all doors activate the PowerStep and the LED lights work when doors open and close.

NORMAL OPERATION: When the doors open, PowerStep automatically deploys from under the vehicle. When the doors are closed, PowerStep will automatically return to the stowed/retracted position. **Note that there is a 2-second delay before the PowerStep returns to the stowed/retracted position.**

CORRECT OPERATION OF LIGHTS: All four lamps will illuminate upon opening any door of vehicle. Lamps will stay on until restowing of both Power Steps or until 5 minutes has expired with the doors open. When the lights timeout after 5 minutes, they can be reilluminated by closing and opening any door of vehicle.

POWER-DEPLOYABLE RUNNING BOARDS OPERATION: AMP Research PowerStep running boards automatically move when the doors are opened to assist entering and exiting the vehicle.



Automatic power deploy:

The running boards will extend down and out when the doors are opened.

Automatic power stow:

The running boards will return to the stowed position when the doors are closed. There will be a 2-second delay before the running boards move to the stowed position.

Automatic stop:

If an object is in the way of the moving running board, the running board will automatically stop. To reset, clear any obstruction, then simply open and close the door to resume normal operation.



Manually set in the deployed (OUT) position for access to the roof:

The running boards can be manually set in the deployed position by firmly holding the step down with your foot while at the same time closing the door. To resume normal operation, open and close the door.

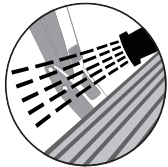

Maintenance: In adverse conditions, debris such as mud, dirt, and salt may become trapped in the running board mechanism, possibly leading to unwanted noise. If this occurs, manually set the running boards to the deployed position and flush the front and rear hinge arms with a high-pressure car wash wand.

Avoid spraying the motors directly. After washing, apply silicone spray lubricant to the hinge pivot pins. Do not apply silicone, wax or protectants like Armor All® to the running board stepping surface.

Caution! Keep hands away when the running board is in motion.