

INSTALLATION GUIDE

AMP RESEARCH Power Step

MADE IN USA

APPLICATION
Toyota Tundra CrewMax

MODEL YR
2007 - 2019

PART #
77137-01A

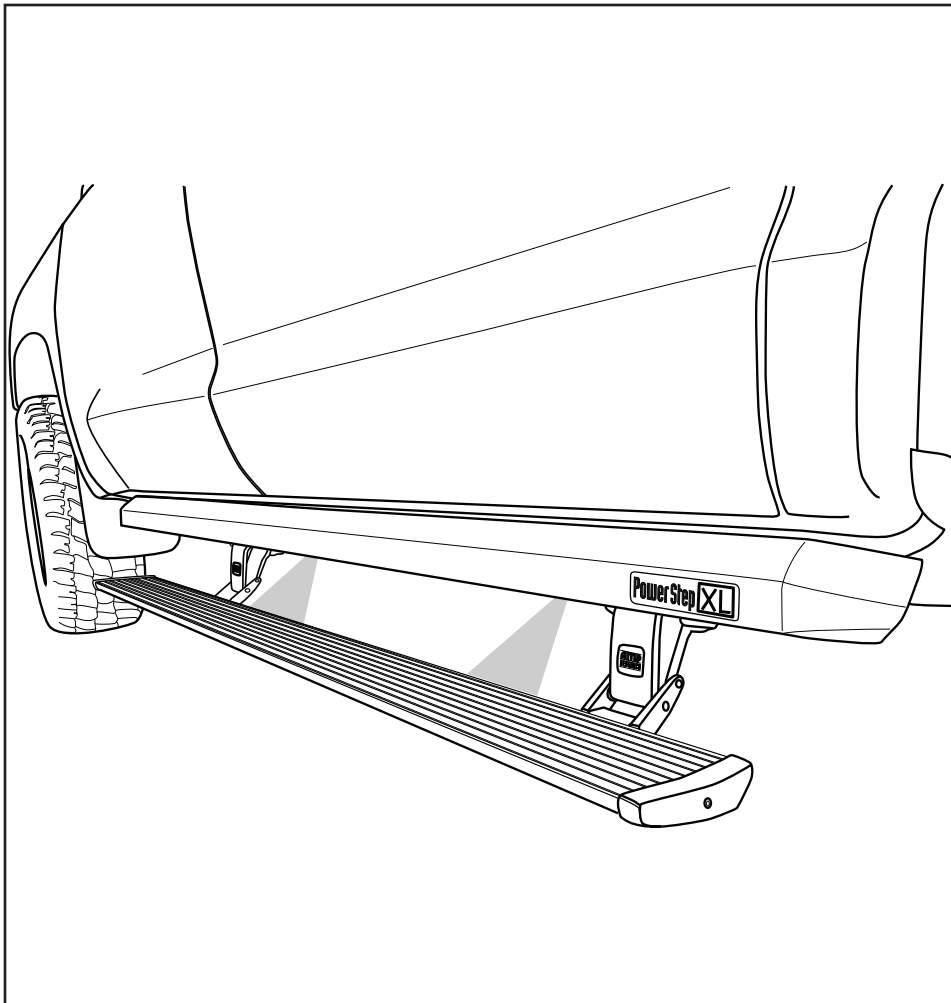

INSTALLATION TIME

3-5 Hours

Professional installation recommended

SKILL LEVEL



4= Experienced

TOOLS REQUIRED

- Measuring tape
- 13 mm socket
- 10 mm socket
- Ratchet wrench and extension
- 13mm end wrench
- Wire stripper / cutter
- 3/16" hex key wrench (allen wrench)
- 5mm hex key wrench (allen wrench)
- 4mm hex key wrench (allen wrench)
- Electrical tape

Invented, engineered and manufactured exclusively by AMP Research in the USA. May be covered by one of the following patents: 6,641,158; 6,830,257; 6,834,875; 6,938,909; 7,055,839; 7,380,807; 7,398,985; 7,584,975 ©2012 AMP Research. All rights reserved. Printed in USA.

EXPLODED VIEW

- Motor
- Hex Head Bolt

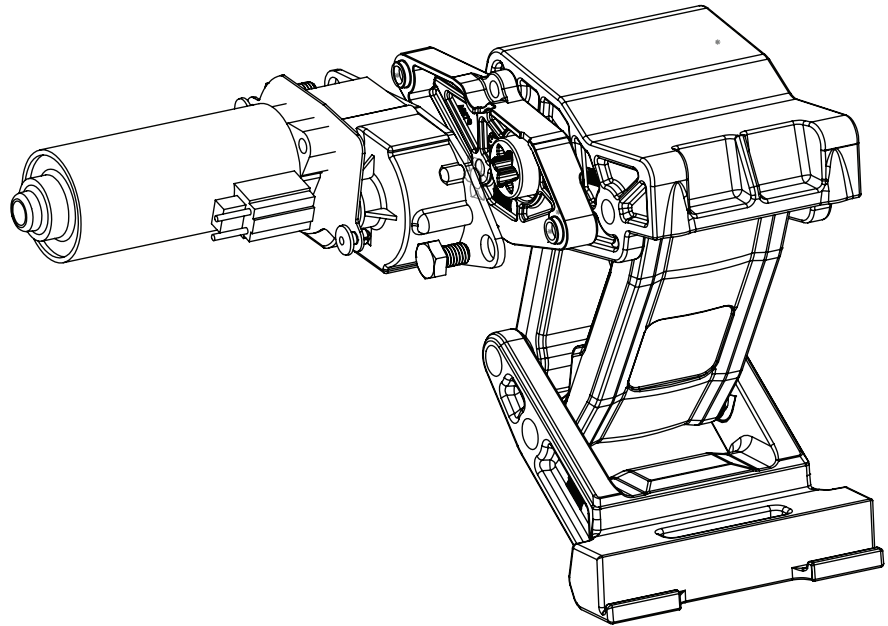

CAUTION: HANDLE WITH CARE.

To ensure our customers receive all components with full integrity, we pack the motors separate from their linkage assemblies. This requires that the installer position and fasten the motor before continuing with the install. Please follow the instructions below and handle the assembly carefully.

CAUTION: Dropping the assembly or any excessive impact MAY cause damage to the motor.

Instructions:

1. Position the gear cover in place as shown if not already in place.
2. Seat motor into position on the three mounting bosses. This may require an adjustment of the gear by moving the swing arms.
3. After seating into place, fasten the motor with the three motor mount screws with 4mm Hex Head. Tighten screws to 36 in-lbs (4N-m). **Do not over torque.**

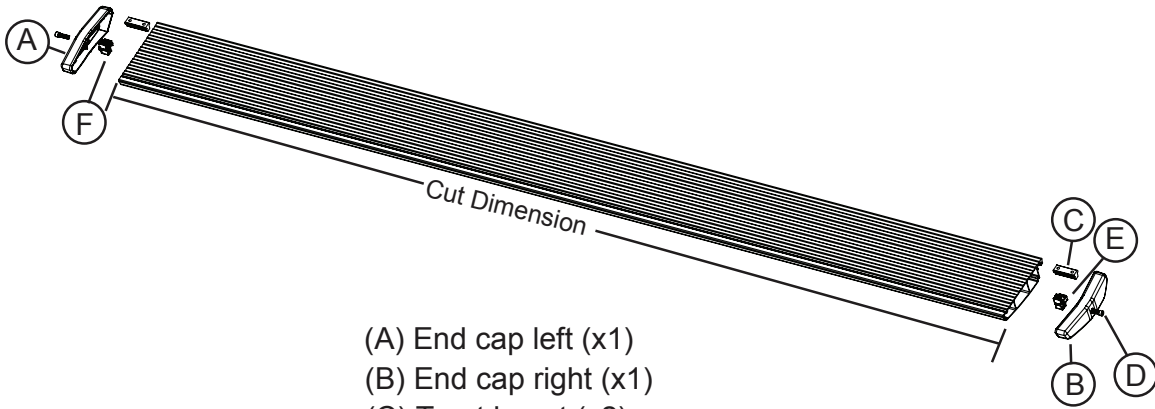

- (A) End cap left (x1)
- (B) End cap right (x1)
- (C) T-nut insert (x2)
- (D) Socket cap screw (x2)
- (E) End cap wedge right (x1)
- (F) End cap wedge left (x1)

1 x2

Running board assembly



2 x2

Rail Assembly

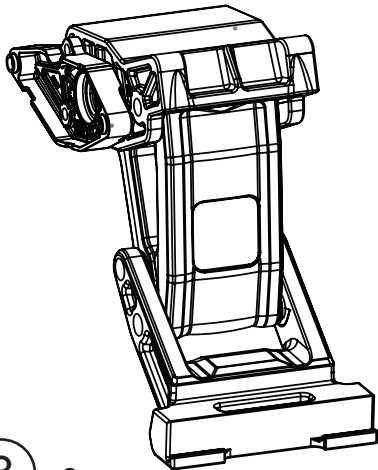

3 x2

Motor linkage assembly

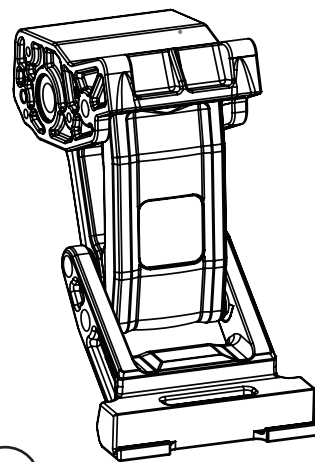

4 x2

Idler linkage assembly

AMP RESEARCH POWERSTEP™ – TOYOTA TUNDRA

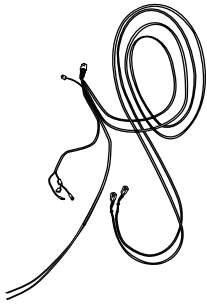

5

Wire harness

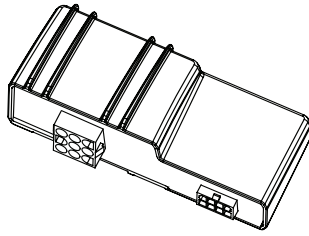

6

Controller STA

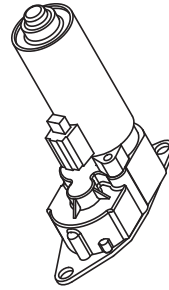

7 x2

Motor

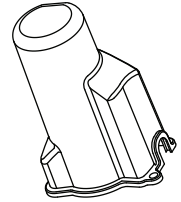

8 x2

Motor Cover



9 x6

Cinch Fastener

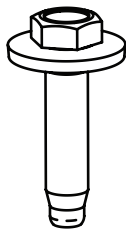

10 x20

M8 Hex Bolt w
Conical washer

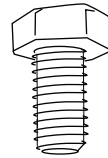

11 x4

M8 Head Hex Bolt

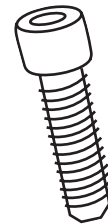

12 x8

Socket Cap Screw

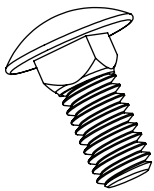

13 x10

5/16-18
Carriage Bolt

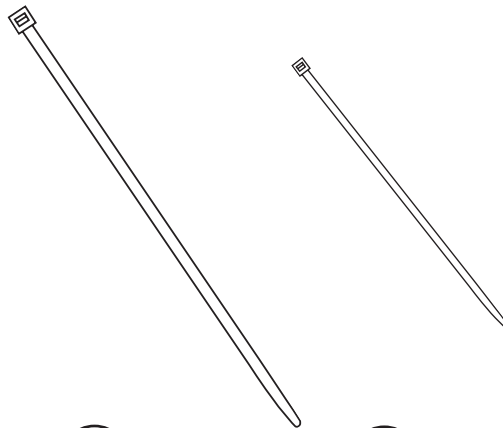

14 x2

Cable tie (11")

15 x20

Cable tie (7")



16 x4

Posi-Tap™

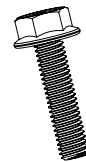

17 x4

M6 Flange Bolt

AMP RESEARCH POWERSTEP™ – TOYOTA TUNDRA

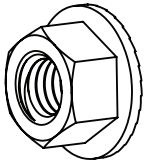

18 x10
5/16-18
Flange Nut

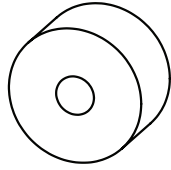

19 x4
Upper Mount
Spacer

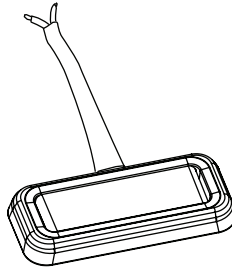

20 x4
LED Lamp

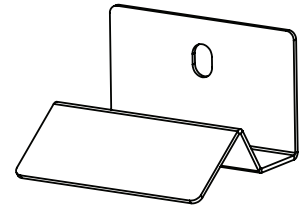

21 x4
LED Light Bracket

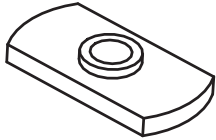

22 x4
Nut Plates



23 x4
Button Head
Bolts

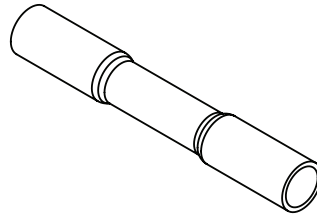

24 x8
Butt Connector

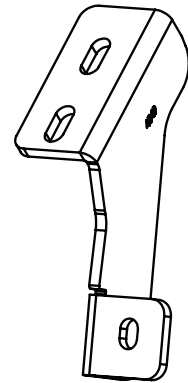

25 x2
Rail Support
Bracket # 4549

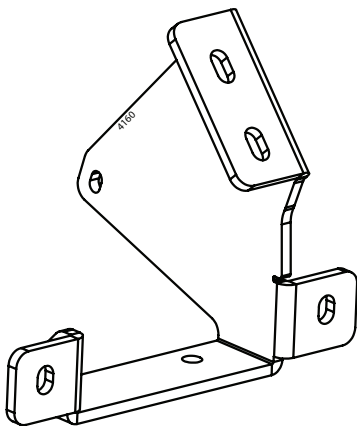

26
Linkage mounting
bracket REAR # 4160

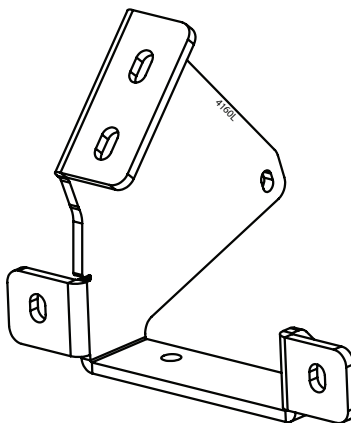

27
Linkage mounting
bracket REAR # 4160L

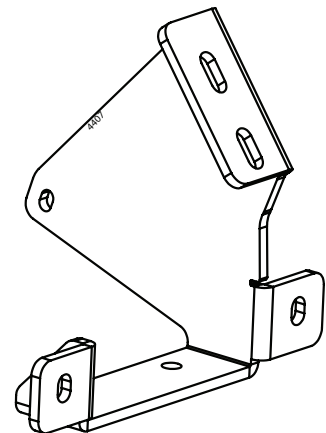

28 x2
Linkage mounting bracket,
FRONT # 4407

Install Front linkage mounting bracket #28 (part# 4407 Front) using supplied Conical Washer bolts #10. Use second set of mounting holes from front. Do not tighten to allow for adjustment. Take note of bracket orientation.

Driver side shown.

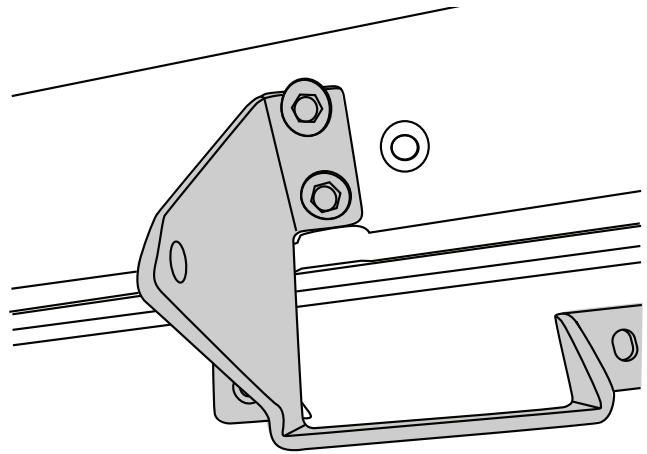

1

Install Rear linkage mounting bracket #27 (part # 4160L Rear) using supplied Conical Washer bolts #10. Use last set of mounting holes. Do not tighten to allow for adjustment. Take note of bracket orientation.

Driver side shown.

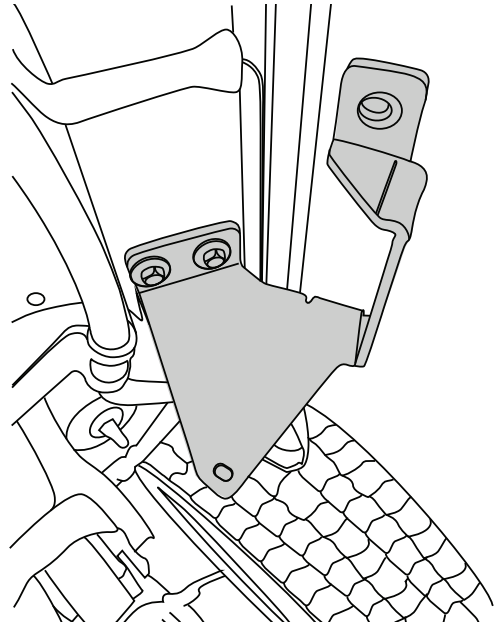

2

Install Rail support bracket #25 (part #4549) using supplied conical washer assembly in middle mounting position on body. Use supplied conical washer bolts #10. Do not tighten to allow for adjustment.

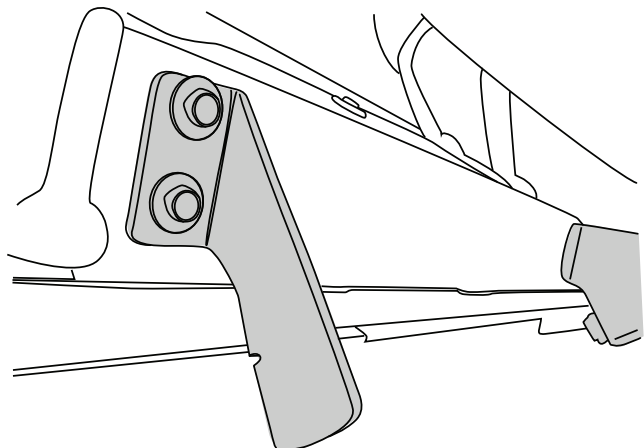

3

AMP RESEARCH POWERSTEP™ – TOYOTA TUNDRA

Install 5 Carriage Bolts #13 into rail. Align bolts with bracket and use supplied Flange nuts #18 to attach Rail to brackets. Do not tighten to allow for adjustment. Insert Threaded nut plate onto rail pocket. Light brackets will need to go rearward of Front linkage bracket and forward of Rear linkage bracket. Leave loose to allow for adjustment.

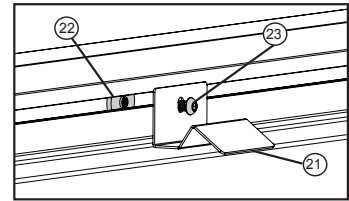
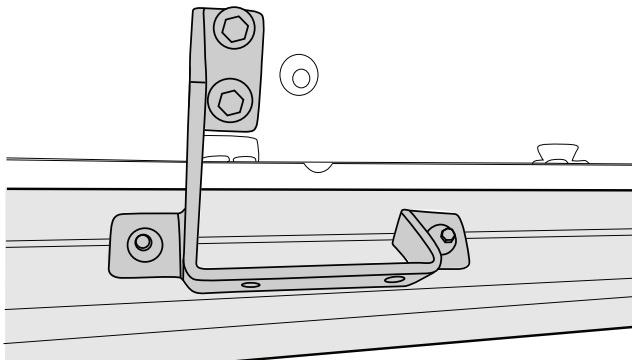

4

Slide rail into position as show. Torque bolts from step 3-5 to 16ft-lbs. Next torque flange nuts that attach rail to brackets to 16ft-lbs.

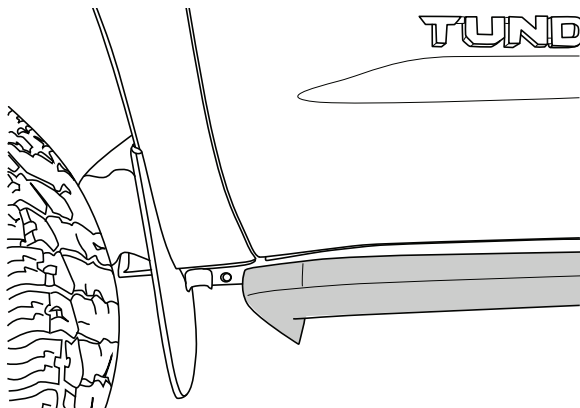

5

On Driver side mount Front drive linkage and rear idler linkage. Thread supplied Conical washer bolts #10 into linkages. Install provided spacer #19 and M6 flange bolt #17 into upper mount as shown on both Drive and Idler linkages. Do not tighten.

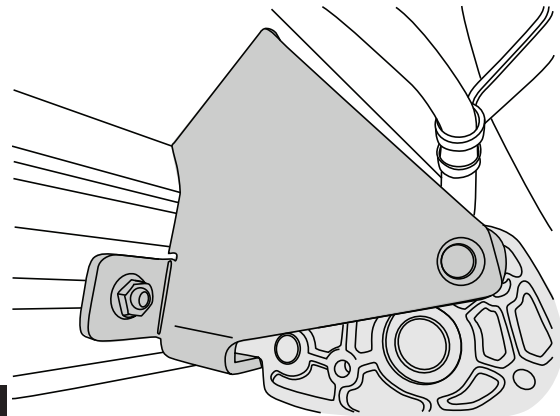

6

Slide mounting T-nut into position. Center Board in rail pocket. Tighten fasteners to 10ft-lb.

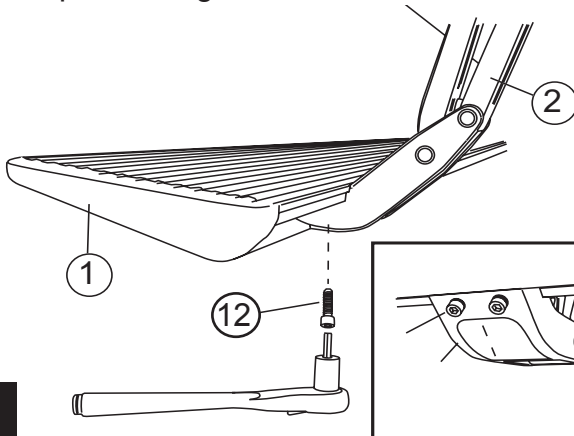

7

Using a 13 mm socket torque linkage bolts to 16ft-lbs. Next use a 10mm socket torque linkage spacer bolt #19 to 8 ft-lbs. Once linkages are tight cycle board to verify steps deploy under own weight and clear rail endcaps.

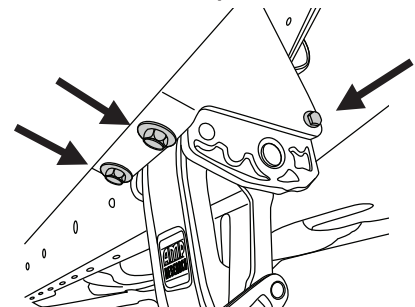

8

AMP RESEARCH POWERSTEP™ – TOYOTA TUNDRA

Install controller #6 under hood on driver side fender apron. Secure to factory wiring loom with 11" cable ties #14.

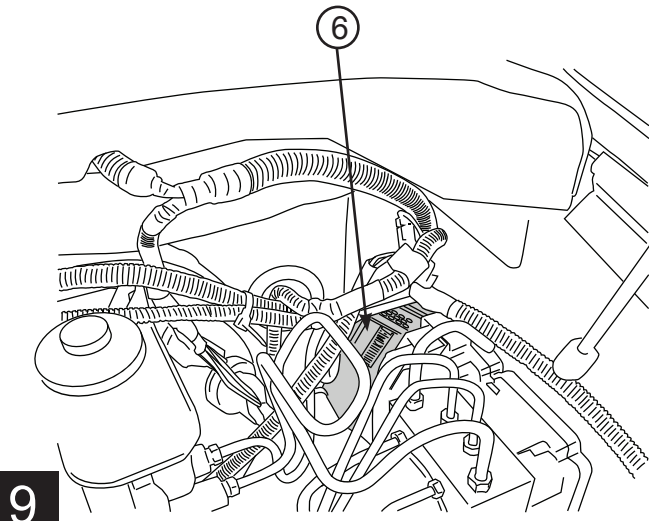

Remove power fuse. Connect wire harness to controller and secure locking clip. Connect red power lead to positive battery terminal and black ground lead to grounding lug on fender apron.

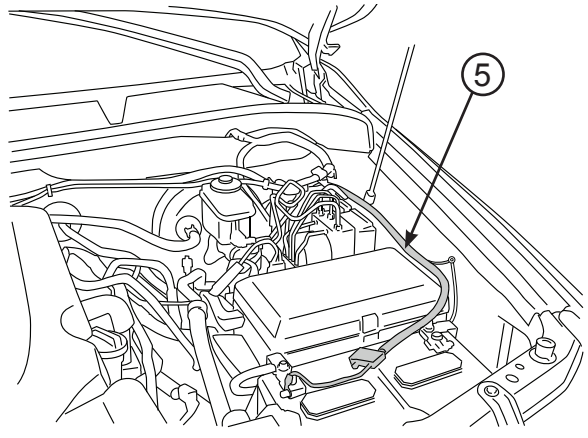

Route longest leg of wire harness across fire wall to passenger side and under vehicle outside of frame rail.

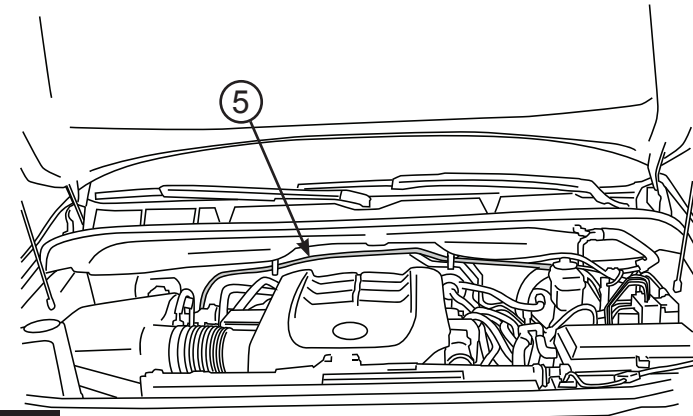

Route shorter leg of wire harness down driver side fender well and under vehicle outside of frame rail.

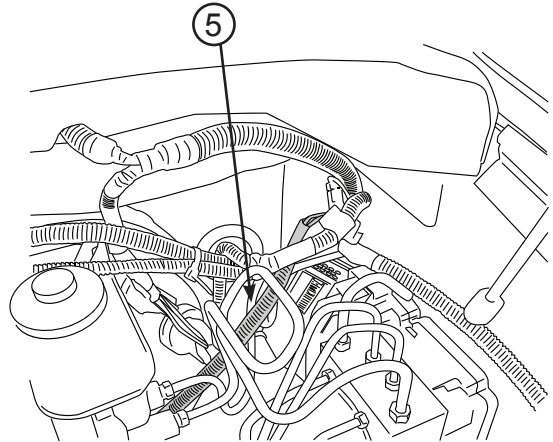

Remove driver and passenger front sill plates and kick panels. Pull up carpet. Locate rubber grommets under carpet in forward floorboards. Cut a slit in the rubber grommets and pass the trigger wires up through grommets under carpet on both the driver and passenger side.

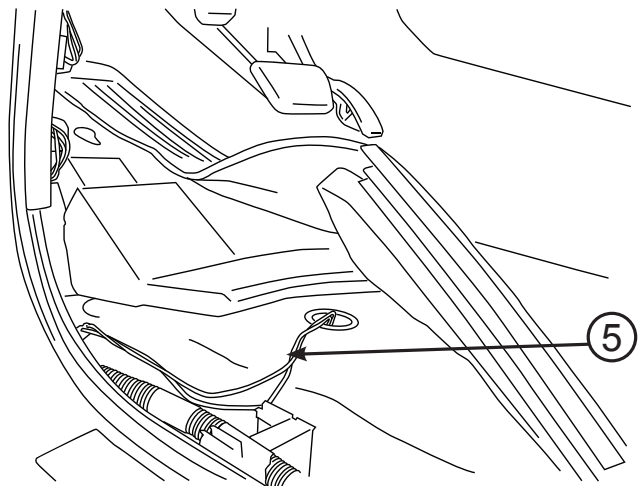

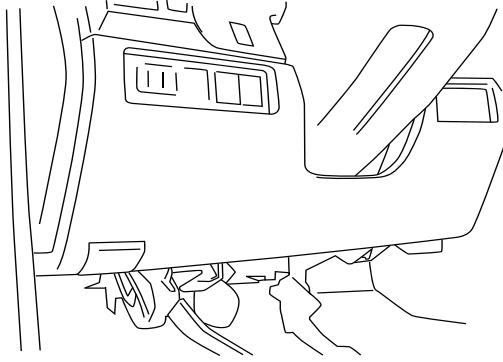

Remove trim panel below steering column

14

Posi-Tap™ instructions

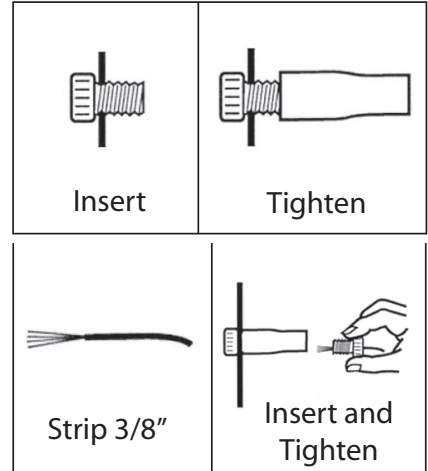

15

2007 - 2017 model years: Locate main electrical junction box located under dash to the left of the steering column. Connect grey Power Step wire to 18 gage black or dark charcoal wire (*Driver Rear*) in pin 2 of upper left connector shown.

2018 model years: Locate the 18 gage pink w/red stripe wire (*Driver Rear*) in Pin 24.

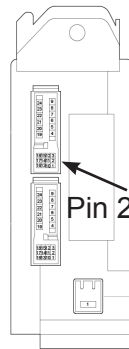
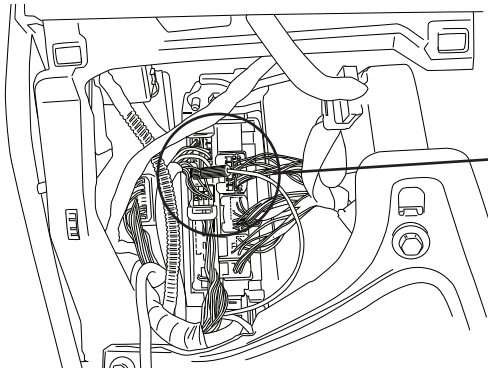

2007 - 2017 Model Years

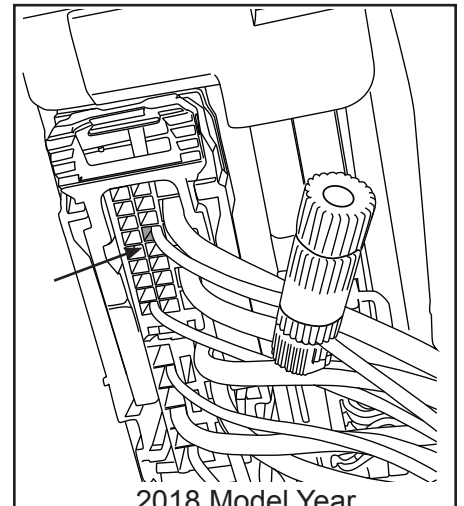

2018 Model Year

16

Locate 20 pin connector at bottom of panel on left. Connect blue Power Step wire to 18 gage blue wire (*Driver Front*) in pin 15 of connector shown. Plugs are located to the left of E Brake Pedal.

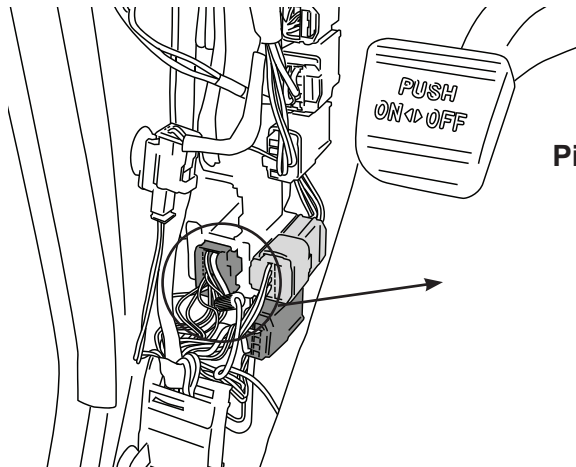

2007-2013 Model Years

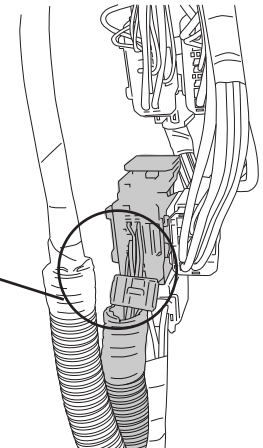
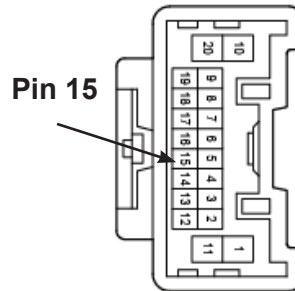

2014 - 2018 Model Years

17

Locate the 22 pin connector at the bottom of the passenger side kick panel area. See pin connector locations for corresponding model years.

(07-13 Model yrs) plug color Grey Pin 1 (*Passenger Rear*) wire color will be Blue and pin 9 (*Passenger Front*) wire will be White.

(2014-17 Model yrs) plug color white Pin 3 (*Passenger Rear*) wire color will be Tan and pin 10 (*Passenger Front*) wire will be Green.

(2018 Model yrs) plug color white Pin 3 (*Passenger Rear*) wire color will be Tan and pin 22 (*Passenger Front*) wire will be Green.

2007-2013 Model Years

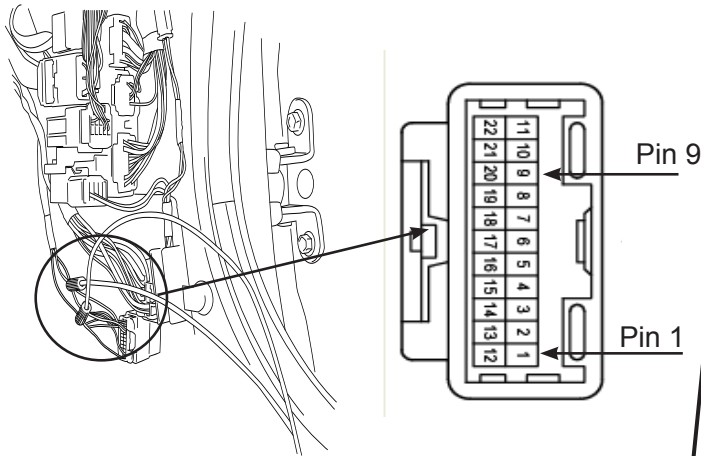

2014-18 Model Years

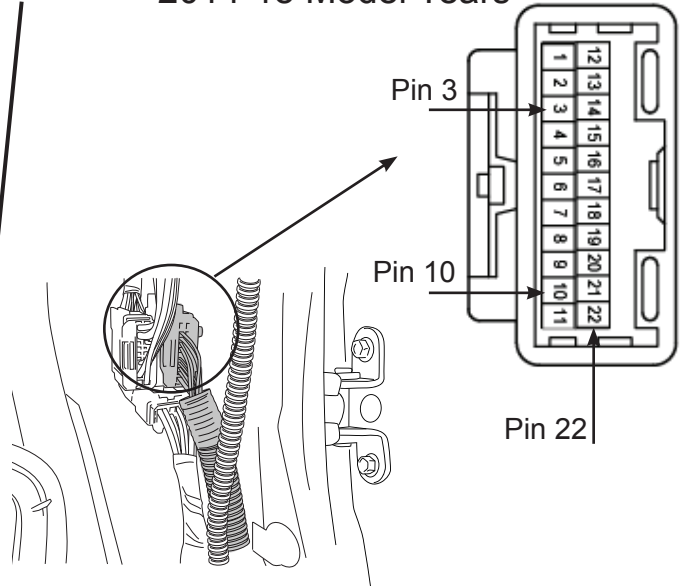

18

Insert plug from wire harness onto motor.

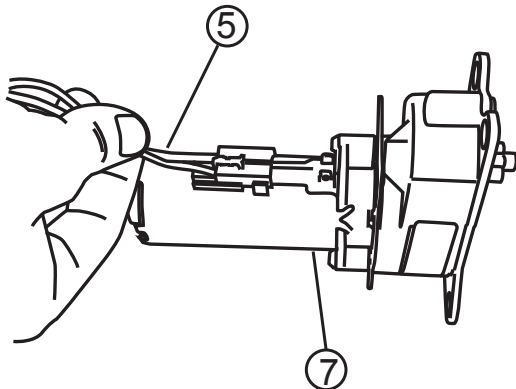

19

Slide rubber grommet on wire harness into slot of motor cover. Install motor cover onto motor.

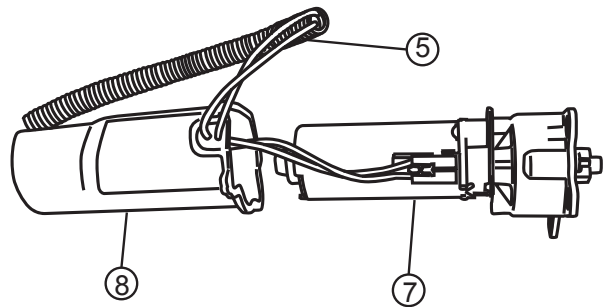

20

Partially separate the plastic rivet from the pin by bending the pin back and forth. Slide motor cover over motor and insert plastic push pin rivets in mounting holes of motor cover. Drive pin flush with rivet head. Use pliers to ease installation.

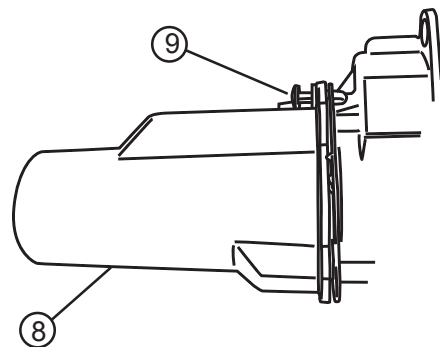

21

AMP RESEARCH POWERSTEP™ – TOYOTA TUNDRA

Affix LED lamp (20) to LED Bracket (21) as shown..

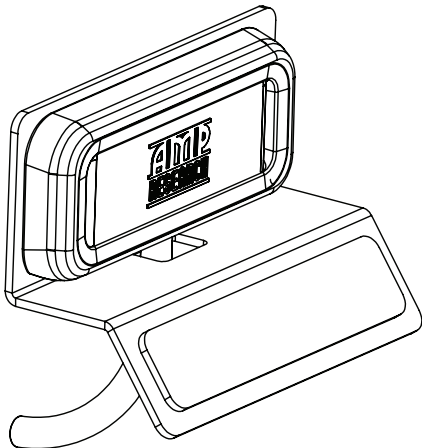

Affix LED light bracket assembly to rail. Mount front light rearward of front linkage and mount rear light just forward of rear linkage.

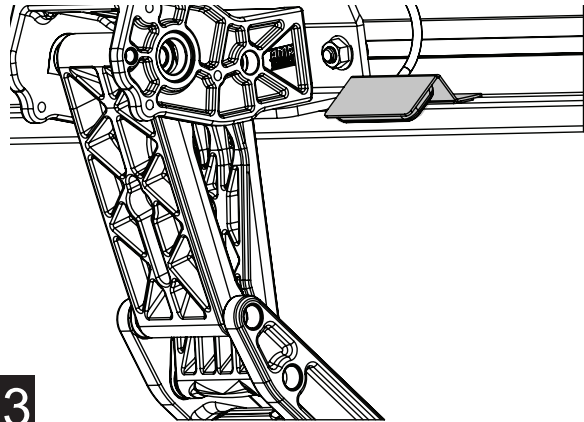

22

23

Using supplied butt connectors, connect the lamp wires. Red to Red, Black to Black. Once Crimped use heat gun to shrink tube.

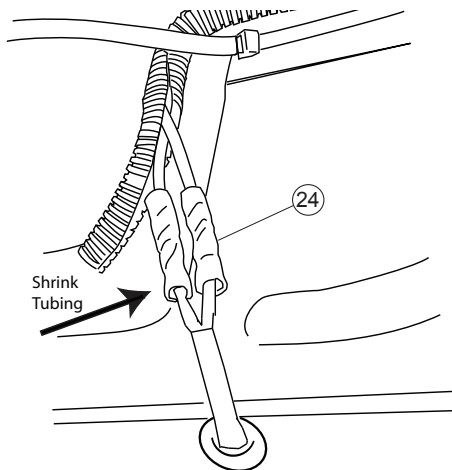

Close and wrap with conduit and electrical tape. Secure all loose wires with cable ties, with lamp wires pulled upward to avoid any wire snagging.

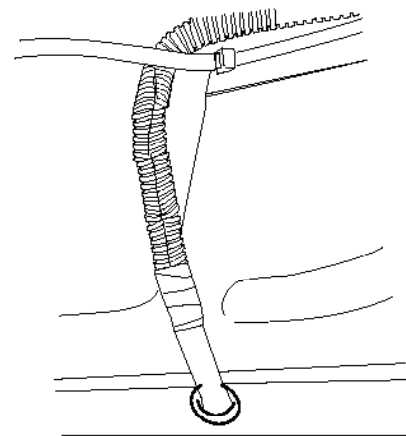

24

25

Reinstall fuse.

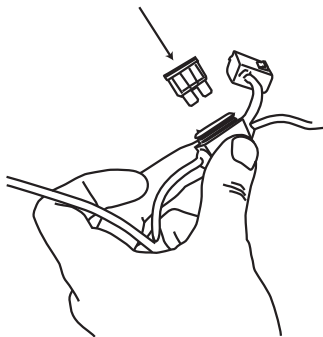

26

Check that all doors activate the Power Step and the LED Lights work when doors open and close. Reinstall any remaining trim panels.

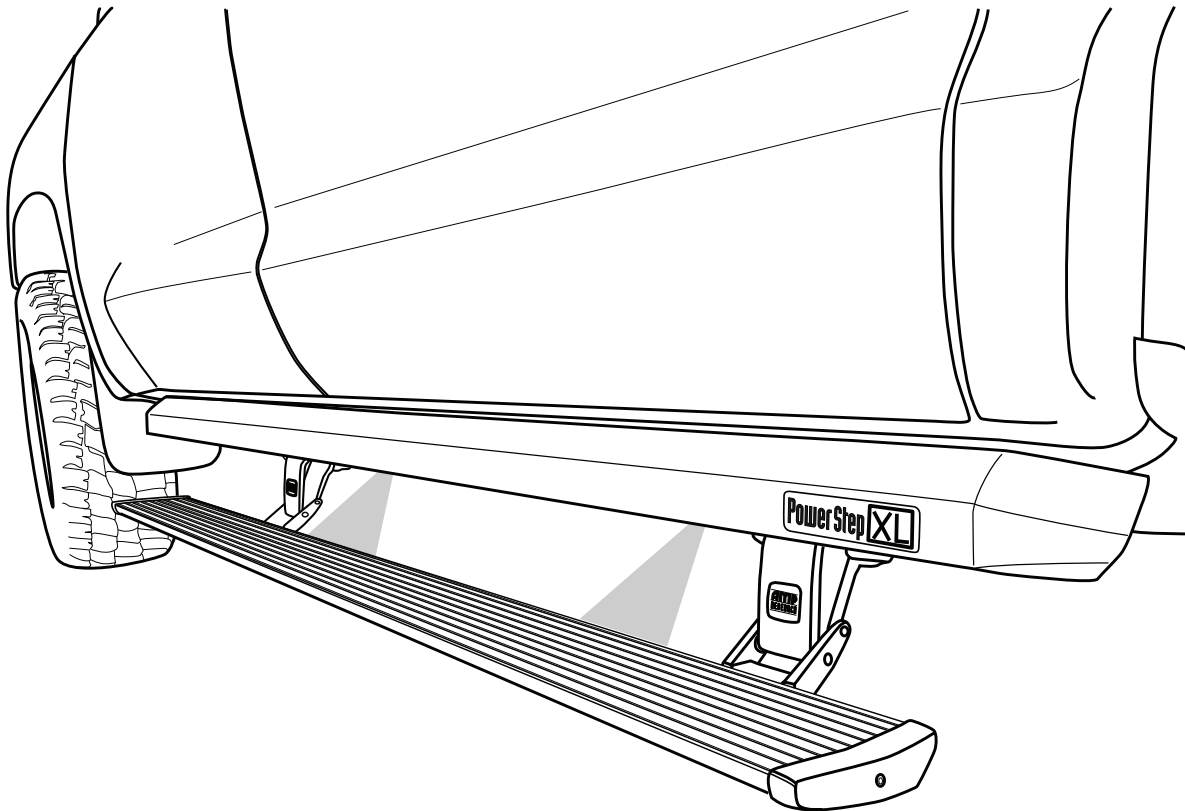

FINAL SYSTEM CHECK

Check that all doors activate the PowerStep and the LED lights work when doors open and close.

NORMAL OPERATION: When the doors open, PowerStep automatically deploys from under the vehicle. When the doors are closed, PowerStep will automatically return to the stowed/retracted position. **Note that there is a 2-second delay before the PowerStep returns to the stowed/retracted position.**

CORRECT OPERATION OF LIGHTS: All four lamps will illuminate upon opening any door of vehicle. Lamps will stay on until restowing of both Power Steps or until 5 minutes has expired with the doors open. When the lights timeout after 5 minutes, they can be reilluminated by closing and opening any door of vehicle.

POWER-DEPLOYABLE RUNNING BOARDS OPERATION: AMP Research PowerStep running boards automatically move when the doors are opened to assist entering and exiting the vehicle.

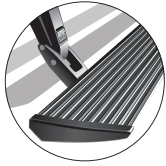

Automatic power deploy:

The running boards will extend down and out when the doors are opened.

Automatic power stow:

The running boards will return to the stowed position when the doors are closed. There will be a 2-second delay before the running boards move to the stowed position.

Automatic stop:

If an object is in the way of the moving running board, the running board will automatically stop. To reset, clear any obstruction, then simply open and close the door to resume normal operation.



Manually set in the deployed (OUT) position for access to the roof:

The running boards can be manually set in the deployed position by firmly holding the step down with your foot while at the same time closing the door. To resume normal operation, open and close the door.

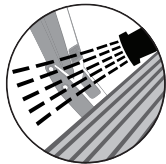

Maintenance: In adverse conditions, debris such as mud, dirt, and salt may become trapped in the running board mechanism, possibly leading to unwanted noise. If this occurs, manually set the running boards to the deployed position and flush the front and rear hinge arms with a high-pressure car wash wand.

Avoid spraying the motors directly. After washing, apply silicone spray lubricant to the hinge pivot pins. Do not apply silicone, wax or protectants like Armor All® to the running board stepping surface.

Caution! Keep hands away when the running board is in motion.