

INSTALLATION GUIDE

AMP **RESEARCH** Power Step MADE IN USA

APPLICATION	LENGTH	MODEL YR	PART #
Ford Expedition MAX	90"	2020	76337-01A

INSTALLATION TIME

2-3 Hours

Professional installation recommended

SKILL LEVEL



4= Experienced

TOOLS REQUIRED

- Safety goggles
- 10 mm socket
- 13 mm socket
- 13 mm end wrench
- Ratchet wrench and extension
- Wire stripper
- 9/32" & 19/64" Drill Bit
- 3/16" hex key wrench (allen wrench)
- 4mm hex key wrench (allen wrench)
- Electrical tape
- Weather proof caulking (silicone sealer)

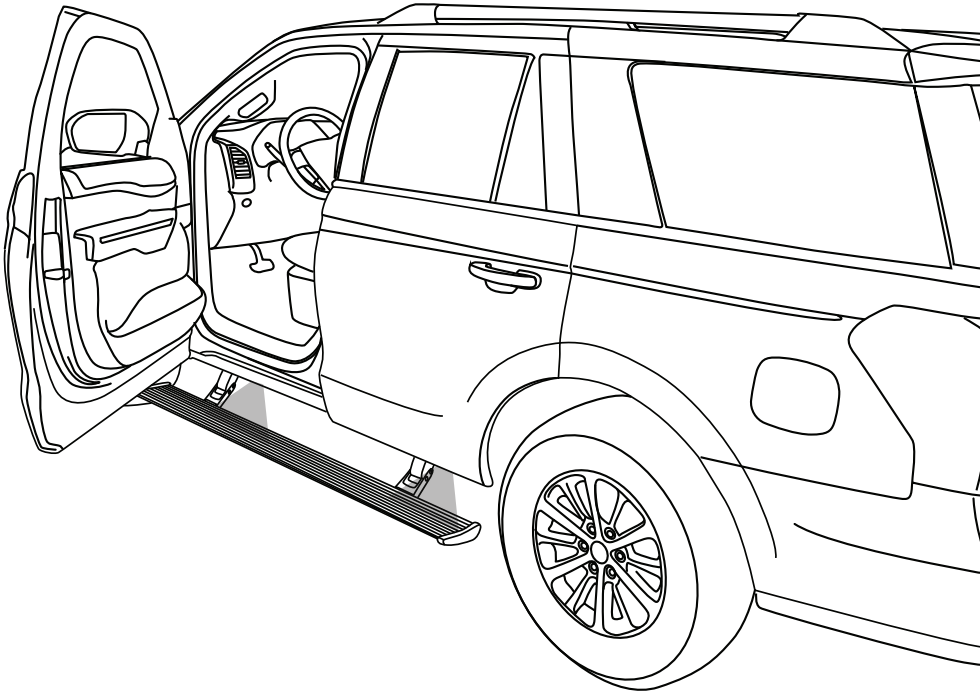

INSTALLATION GUIDE

Attaching motor to linkage assembly

The motors must be attached to the linkage assemblies after linkage installation, after Step 1.

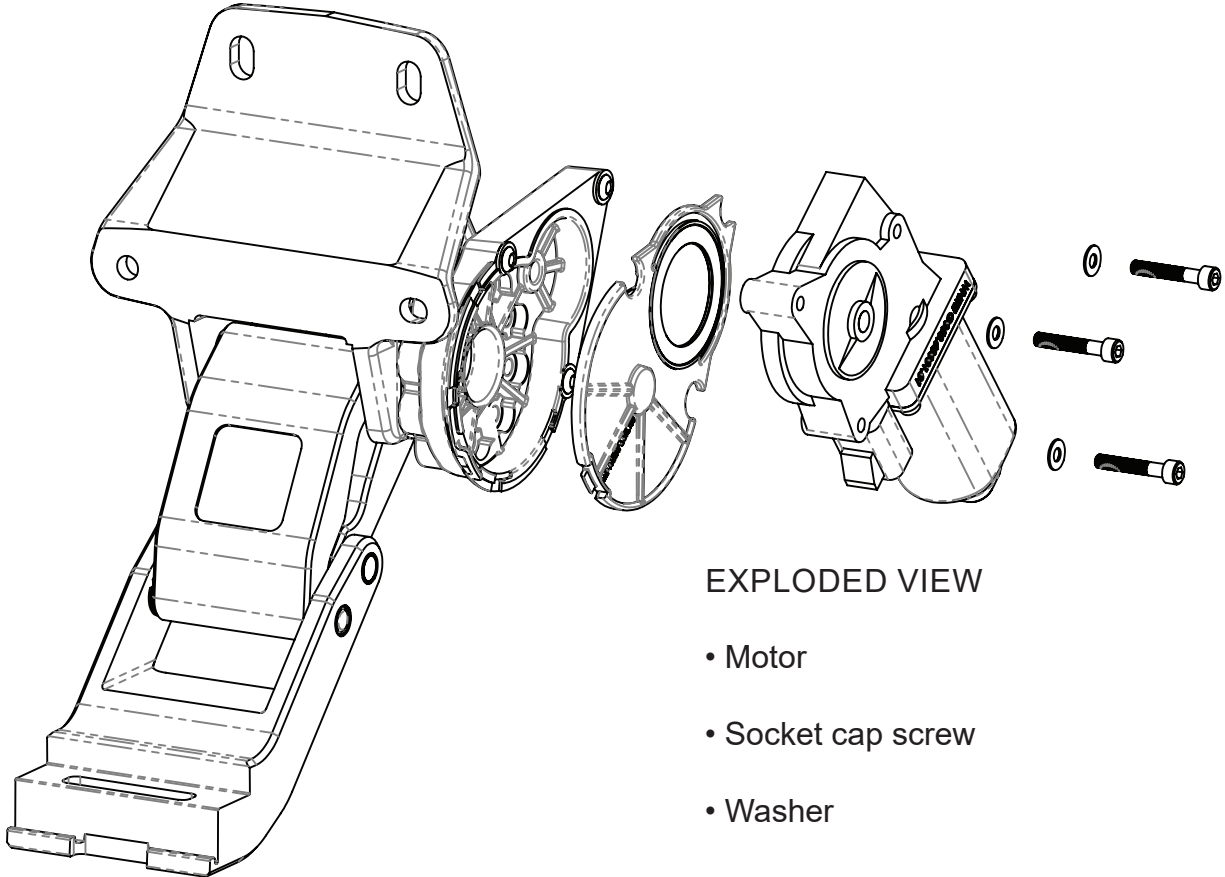

EXPLODED VIEW

- Motor
- Socket cap screw
- Washer

CAUTION: HANDLE WITH CARE.

To insure our customers receive all components with full integrity, we pack the motors separate from their linkage assemblies. This requires that the installer position and fasten the motor before continuing with the install. Please follow the instructions below and handle the assembly carefully.

CAUTION: Dropping the assembly or any excessive impact MAY cause damage to the motor.

Instructions:

1. Position the gear cover in place as shown if not already in place.
2. Seat motor into position on the three mounting bosses. This may require an adjustment of the gear by moving the swing arms.
3. After seating into place, fasten the motor with the three motor mount screws with 4mm allen wrench. Tighten screws to 36 in-lbs (4N-m). Do not over torque.

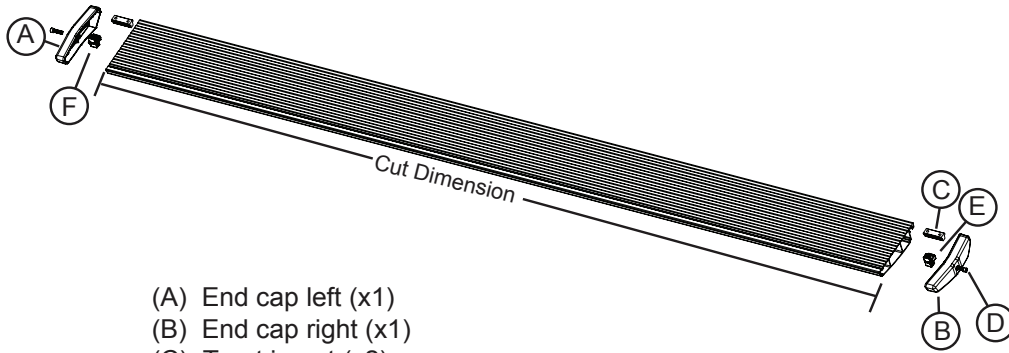

- (A) End cap left (x1)
- (B) End cap right (x1)
- (C) T-nut insert (x2)
- (D) Socket cap screw (x2)
- (E) End cap wedge right (x1)
- (F) End cap wedge left (x1)

1 x2

Running board assembly

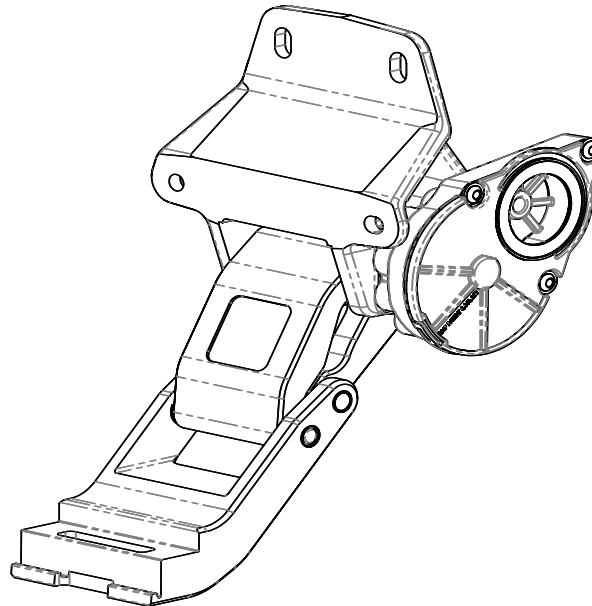

2 x4

Motor linkage assembly

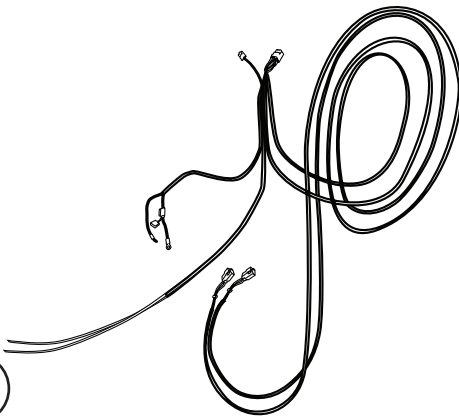

3

Wire harness

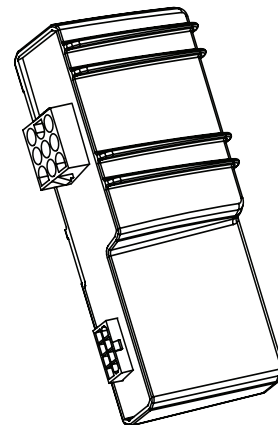

4

Controller XTA

PARTS LIST AND
HARDWARE
IDENTIFICATION



5 x2
Posi-Lock™ (Grey)

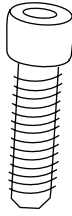

6 x8
Socket cap screw

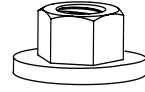

7 x12
Nut with Conical Washer

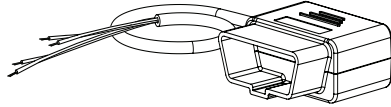

8
ODB II Plug

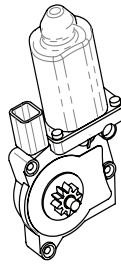

9 x4
Motor

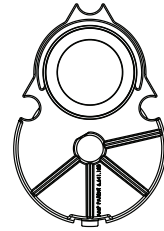

10 x4
Gear Cover

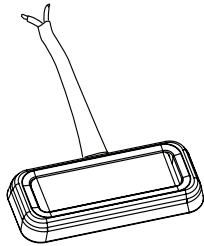

11 x4
LED Light



12 x4
Grommet

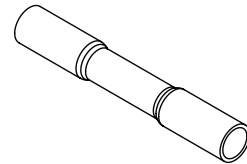

13 x8
Butt Connector

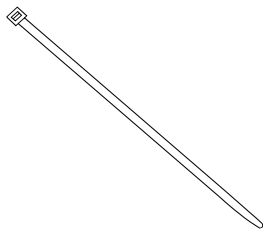

14 x20
Cable Ties 7"

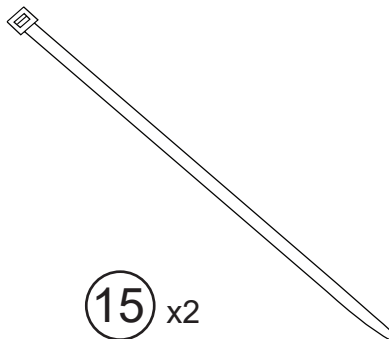

15 x2
Cable Ties 11"



16 x2
Posi-Tap™ (Pink)

Locate mounting points; first and last set of studs on the inner sill. Driver side shown below.

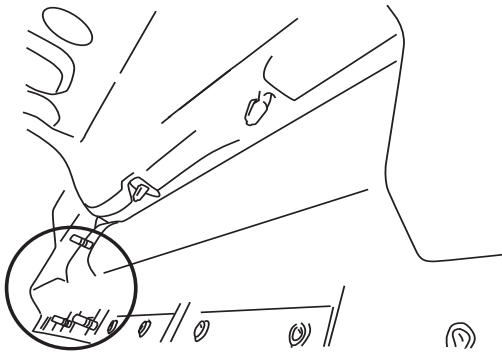

Driver Side Rear Stud Location

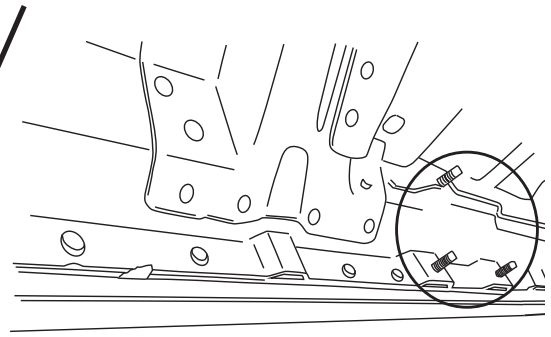

Driver Side Front Stud Location

1

Mount front drive linkage assembly. **Install the nut(12), on the motor side of the linkage, as the linkage goes on, due to little install clearance.** An open end wrench is needed at shallow angles, down and at the opposite angle upward.

Repeat for passenger side. Make sure linkages sit square, fully resting on studs before tightening. Torque to 16 ft. lbs (22Nm).

**Drive Linkage (Front)
Motor Angle**

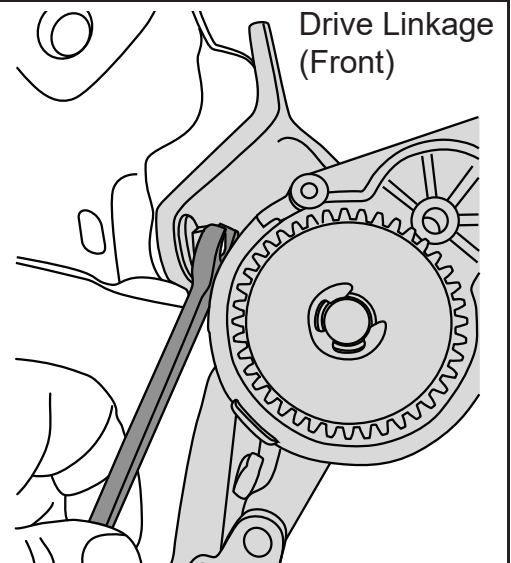
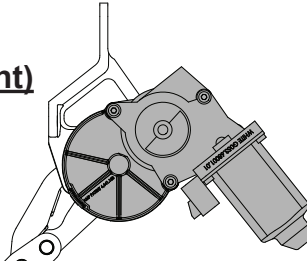

Drive Linkage
(Front)

2

Mount rear Motor linkage assembly with three nuts(12). (Driver side rear linkage is recommended for the motor to be installed first). Repeat for passenger side. Make sure linkages sit square, fully resting on studs before tightening. Torque to 16 ft. lbs (22Nm).

**Drive Linkage (Rear)
Motor Angle**

It is recommended to install the motor first onto the Driver side rear linkage.

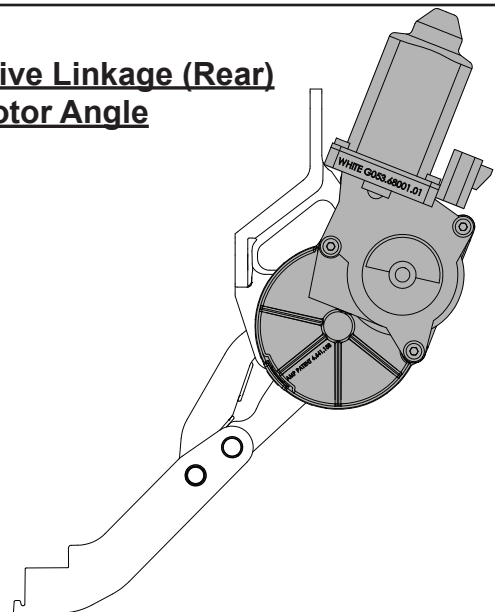

3

Remove fuse from wire harness

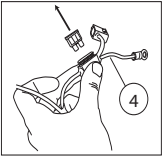

Attach wire harness to controller (make sure connector locking tabs fully engage). Mount controller with the two 11" tie wraps to factory conduit, just forward of battery.

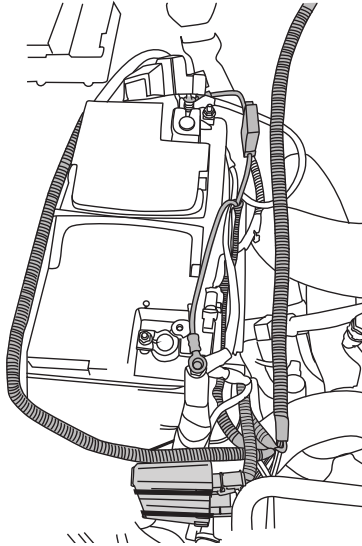

4

Connect red and black power leads to battery accessory studs. Red lead goes to positive. Route shorter leg of harness down passenger-side wheel well and longer leg of harness down along driver side wheel well. Secure with tie wraps.

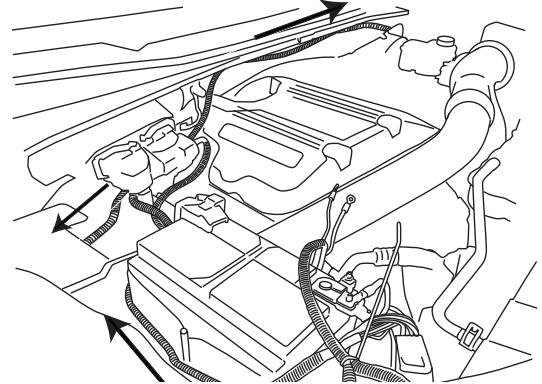

5

Route factory harness underneath vehicle and plug in motors (both sides). Route remaining LED light wires back towards rear of vehicle.

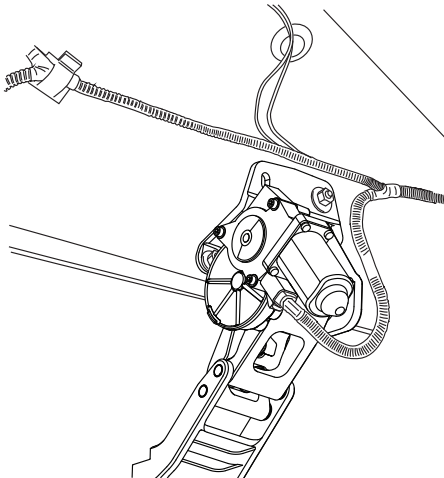

6

Remove driver side front kick panel and door sill plate. Roll back carpet to access hole for passing trigger wires into cab of vehicle.

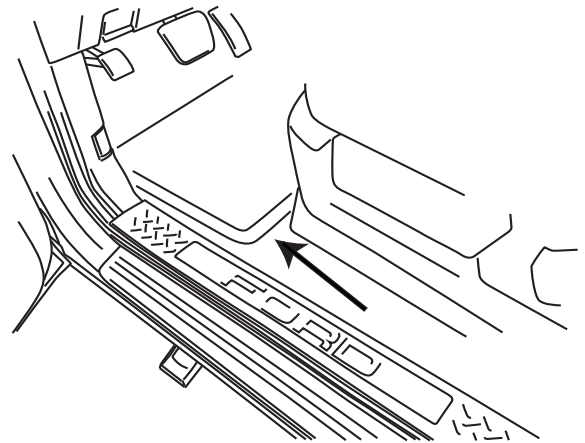

7

Remove grommet in floor panel above front linkage on driver side. Poke small hole into grommet and thread the two trigger wires through and up into the cabin of vehicle. Seal grommet with silicone sealer.

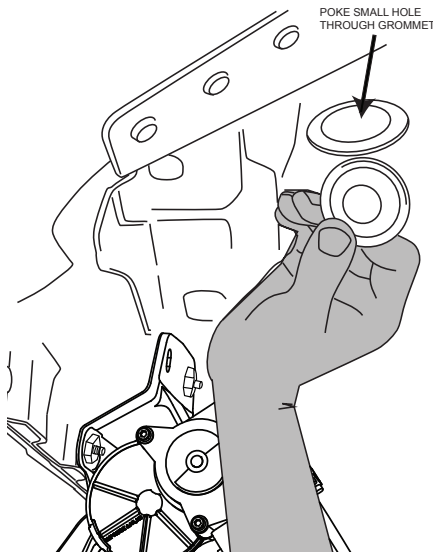

8

Locate OBD port and remove bolt and nut holding it in place with 8mm socket to gain better access to back side of plug.

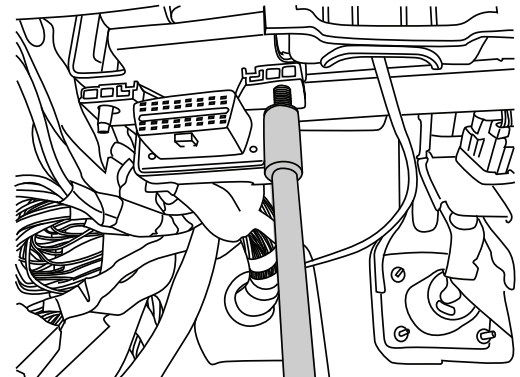

9

Locate the following wires and connect with supplied Posi-Tap™ to the following wire colors listed below.

Factory Can Wire	OBD Module wire Color
Grey with Orange Stripe	White Wire
Purple with Orange Stripe	Blue Wire

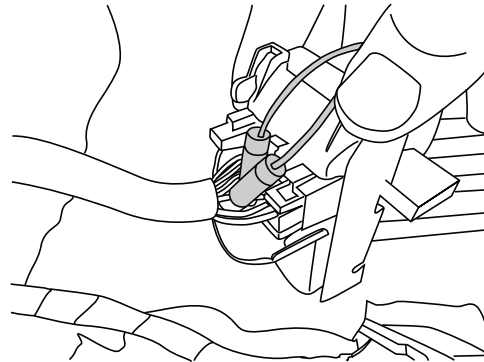
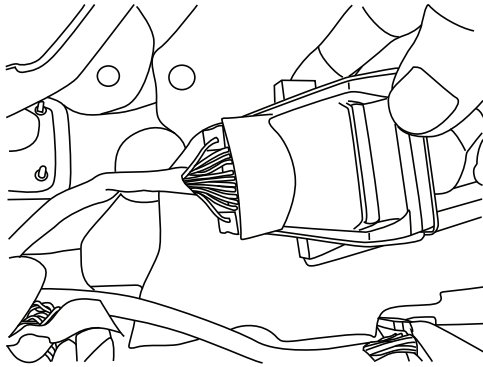

10

Use supplied Posi-Lock™ connectors to attach the 2 purple wires of the obd harness to the main harness. Attach matching colors on the harness to the wires on the module. Lastly reinstall Factory OBD port removed in step 11. Plug in module to OBD port on the vehicle.

Reinstall sill plate removed from step 8.

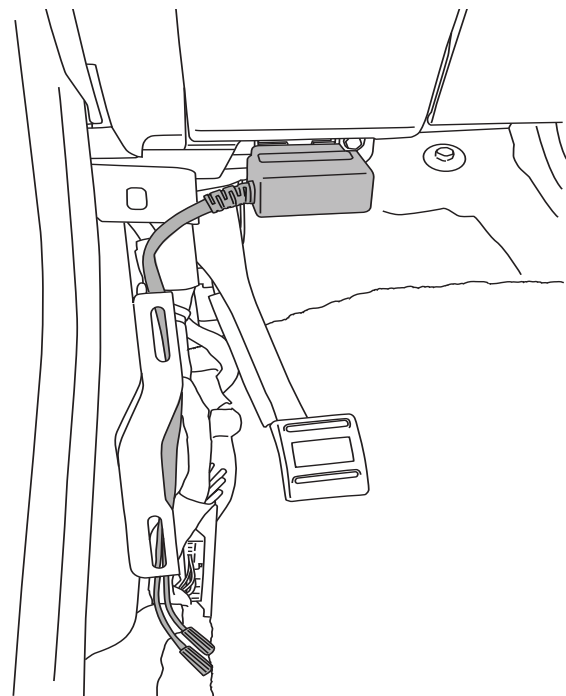

11

OBD II install: Use Supplied Posi Twist connectors to attach the Plug and Play Module to the Harness. Attach matching colors on the harness to the wires on the module. Plug in module to OBD II port on the vehicle. Secure harness with supplied tie wraps.

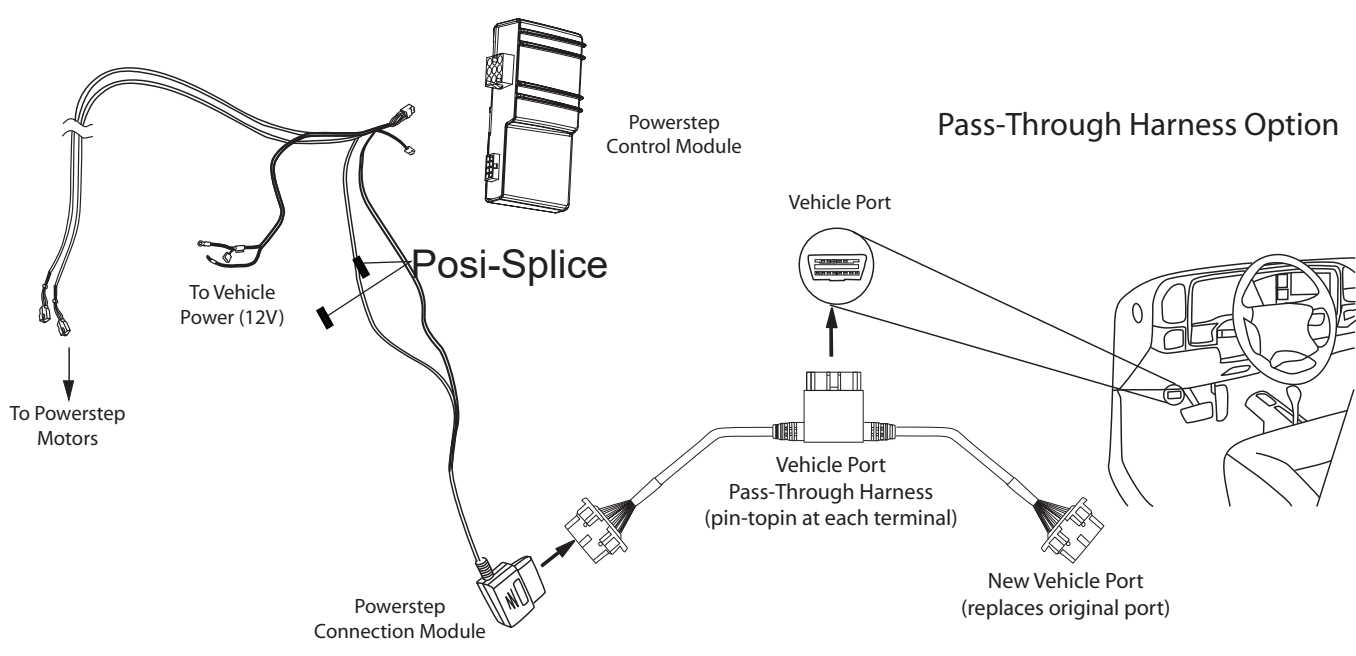
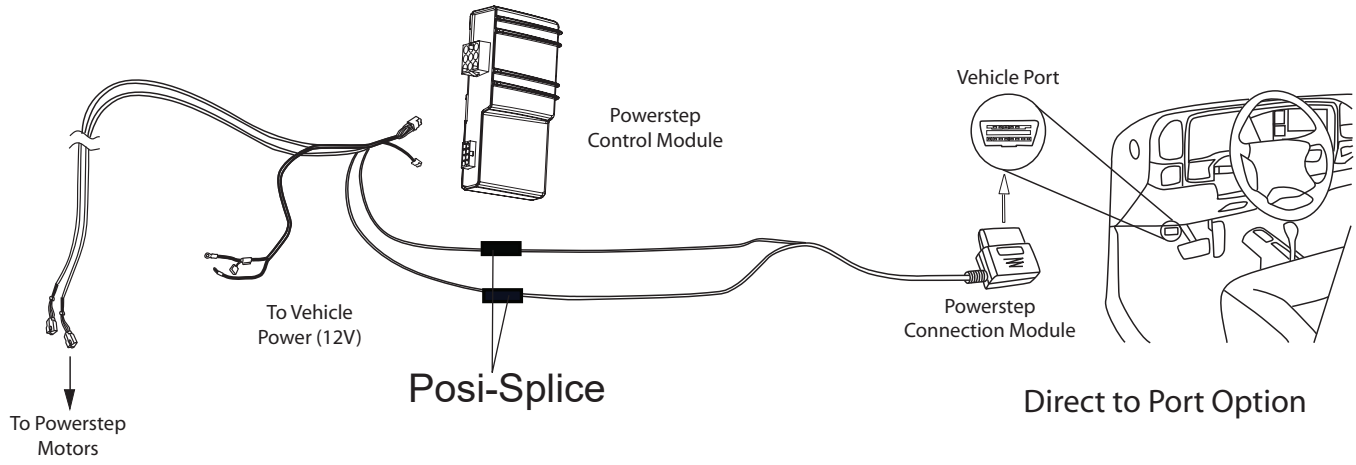

Attach step, sliding the mounting T-nut into position. Torque to 10 ft lbs (13.5 Nm)

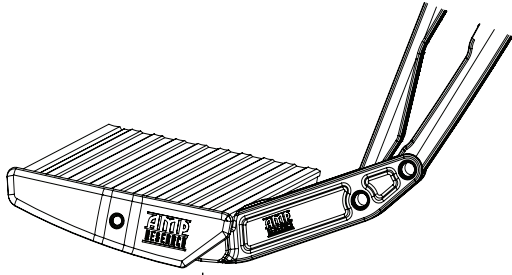

13

The boards should be centered on the rocker on each side of the vehicle.

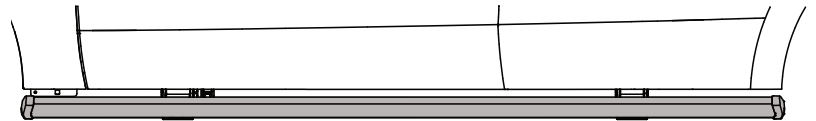

Drive Side Shown
Front of Vehicle



14

On each side of the vehicle there are factory holes to route the led wires and grommets through. The third hole from the front of the pinchweld (not including the fender mount) is to be used for the front LEDs. Use the hole just in front of the rear Linkage for the rear LEDs.

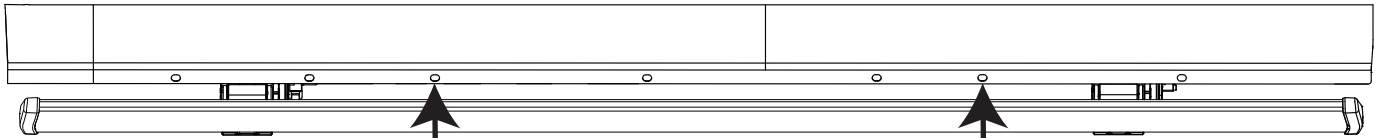

Drive Side Shown
Front of Vehicle



Front LED Hole

Rear LED Hole

15

Insert grommet (12) for LED Wire into labeled holes above. Route LED (11) wires though through grommet, clean surface, and stick on to rocker panel as shown below. The lights go on behind the weather stripping, which might need to be pulled out of the way slightly to install.

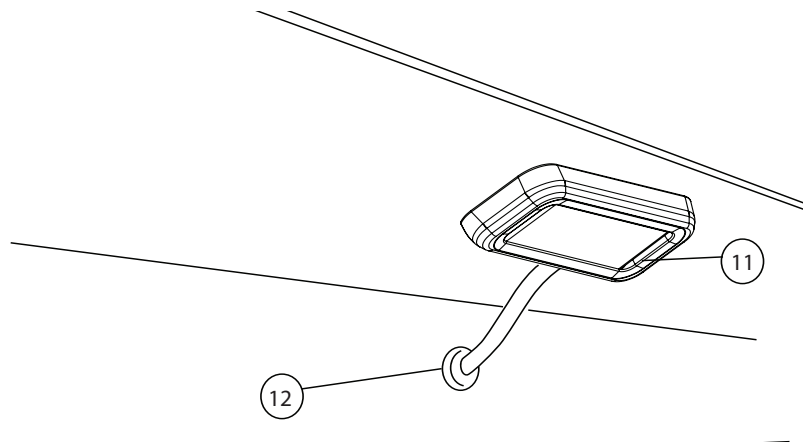

16

Using supplied butt connectors, connect the lamp wires. Red to Red, Black to Black. Heat the shrink tubing on the connectors to seal wires.

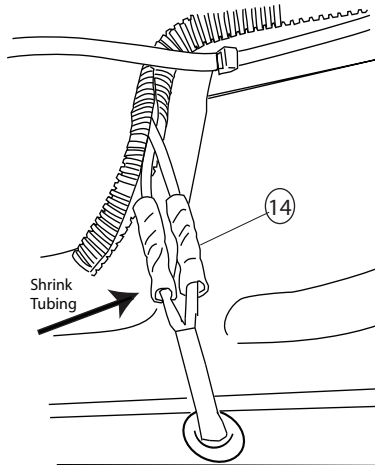

Close and wrap with conduit and electrical tape. Secure all loose wires with cable ties with lamp wires pulled upward to avoid any wire snagging.

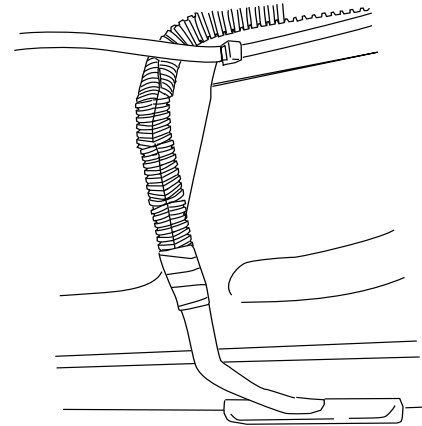

17

18

Replace fuse.

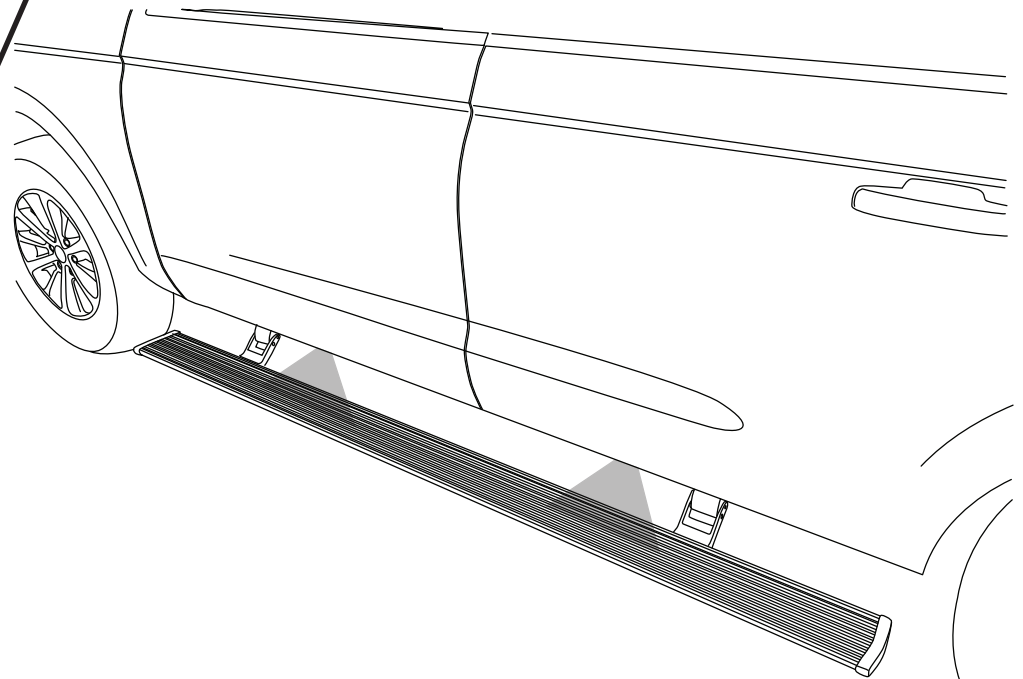
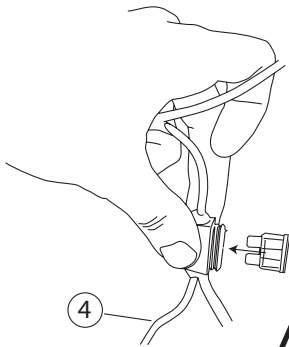

FINAL SYSTEM CHECK

Check that all doors activate the PowerStep and the LED lights work when doors open and close.

NORMAL OPERATION: When the doors open, PowerStep automatically deploys from under the vehicle. When the doors are closed, PowerStep will automatically return to the stowed/retracted position. **Note that there is a 2-second delay before the PowerStep returns to the stowed/retracted position.**

CORRECT OPERATION OF LIGHTS: All four lamps will illuminate upon opening any door of vehicle. Lamps will stay on until restowing of both Power Steps or until 5 minutes has expired with the doors open. When the lights timeout after 5 minutes, they can be reilluminated by closing and opening any door of vehicle.



PowerStep™

Congratulations on your purchase of the genuine AMP Research PowerStep! Here's what you should know...

POWER-DEPLOYABLE RUNNING BOARDS OPERATION: AMP Research PowerStep running boards automatically move when the doors are opened to assist entering and exiting the vehicle.

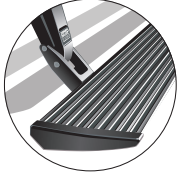

Automatic power deploy:

The running boards will extend down and out when the doors are opened.

Automatic power stow:

The running boards will return to the stowed position when the doors are closed. There will be a 2-second delay before the running boards move to the stowed position.

Automatic stop:

If an object is in the way of the moving running board, the running board will automatically stop. To reset, clear any obstruction, then simply open and close the door to resume normal operation.



Manually set in the deployed (OUT) position for access to the roof:

The running boards can be manually set in the deployed position by firmly holding the step down with your foot while at the same time closing the door. To resume normal operation, open and close the door.

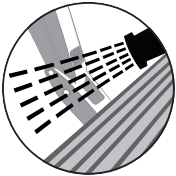

Maintenance: In adverse conditions, debris such as mud, dirt, and salt may become trapped in the running board mechanism, possibly leading to unwanted noise. If this occurs, manually set the running boards to the deployed position and flush the front and rear hinge arms with a high-pressure car wash wand. Avoid spraying the motors directly. After washing, apply silicone spray lubricant to the hinge pivot pins. Do not apply silicone, wax or protectants like Armor All® to the running board stepping surface.

Caution! Keep hands away when the running board is in motion.