

INSTALLATION GUIDE

AMP RESEARCH Power Step

MADE IN USA

APPLICATION

AMP Part #

Ram 1500	Crew Cab	2019 - 2020
Ram 1500	Quad Cab	2019 - 2020

76240-01A
76240-01A

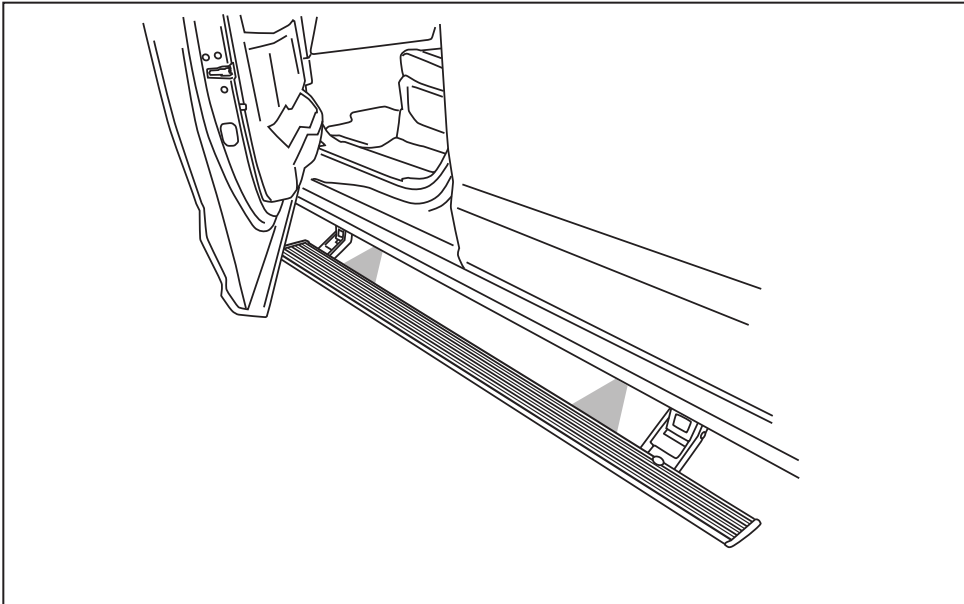

INSTALLATION TIME

3-5 Hours

Professional installation recommended

SKILL LEVEL



4= Experienced

TOOLS REQUIRED

- Safety goggles
- Measuring tape
- 10 mm socket
- 13 mm socket
- 1/2" socket
- Ratchet wrench and extension
- Wire crimpers
- Wire stripper / cutter
- 3/16" hex key wrench (allen wrench)
- 4mm hex key wrench (allen wrench)
- Electrical tape
- Weather proof caulking (silicone sealer)
- Silicone spray

EXPLODED VIEW

- Motor
- Socket cap screw
- Washer
- Drive Gear Housing Cover

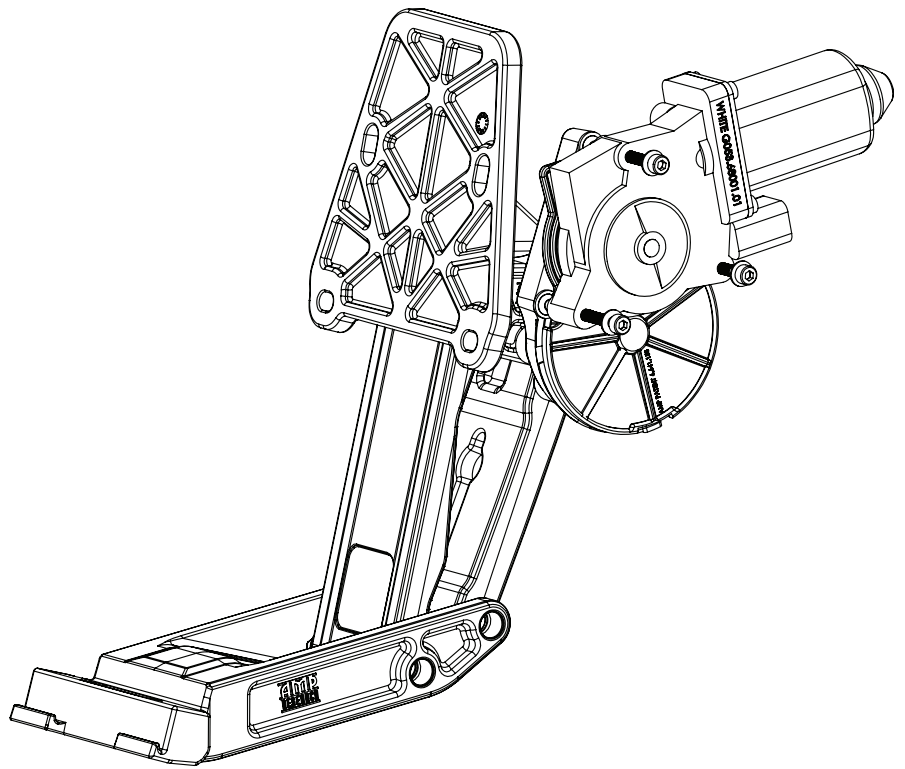

CAUTION: HANDLE WITH CARE.

To ensure our customers receive all components with full integrity, we pack the motors separate from their linkage assemblies. This requires that the installer position and fasten the motor before continuing with the install. Please follow the instructions below and handle the assembly carefully.

CAUTION: Dropping the assembly or any excessive impact MAY cause damage to the motor.

Instructions:

1. Position the gear cover in place as shown if not already in place.
2. Seat motor into position on the three mounting bosses. This may require an adjustment of the gear by moving the swing arms.
3. After seating into place, fasten the motor with the three motor mount screws with 4mm Hex Head. Tighten screws to 36 in-lbs (4N-m). **Do not over torque.**

AMP RESEARCH POWERSTEP™ – Ram

Note: Some Applications require modification.

Application	Cut Length
Crew Cab	79" (No Modification Required)
Quad Cab	72" (Trim 7")

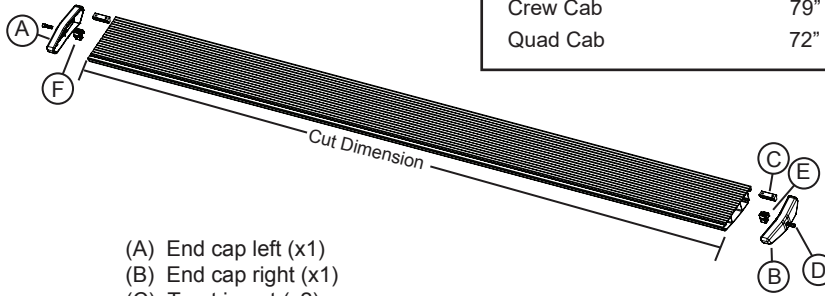

- (A) End cap left (x1)
- (B) End cap right (x1)
- (C) T-nut insert (x2)
- (D) Socket cap screw (x2)
- (E) End cap wedge right (x1)
- (F) End cap wedge left (x1)

1 x2

Running board assembly

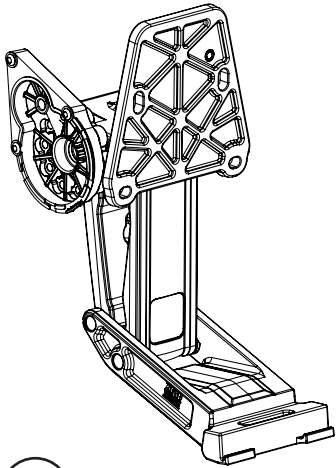

2

Motor Linkage assembly
Driver

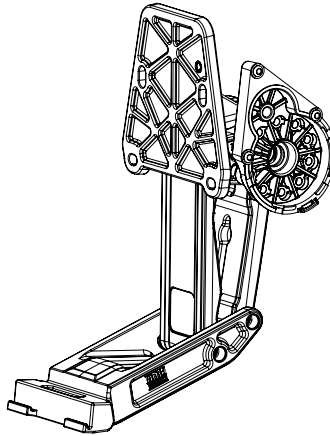

3

Motor Linkage assembly
Passenger

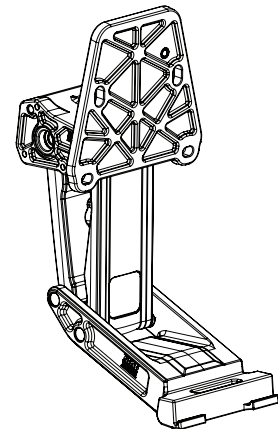

4 x2

Idler Linkage assembly

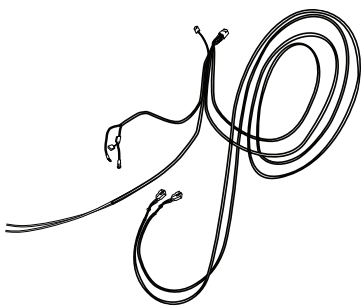

5

Wire harness

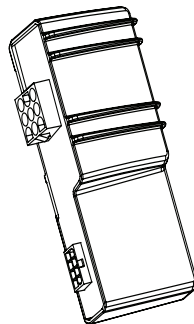

6

Controller STA



7 x2

Posi Lock

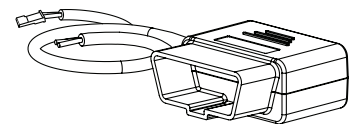

8

OBD II Plug

AMP RESEARCH POWERSTEP™ – Ram Crew Cab

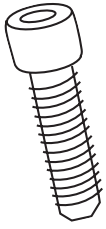

9 x8
Socket Cap Screw

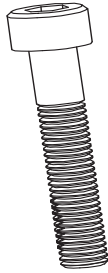

10 x6
M5 Socket Cap Screw

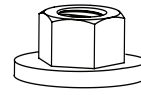

11 x12
Nut with Conical Washer

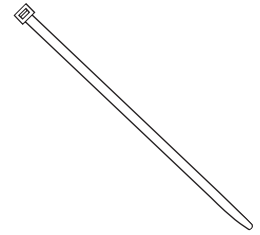

12 x20
Cable tie (7")

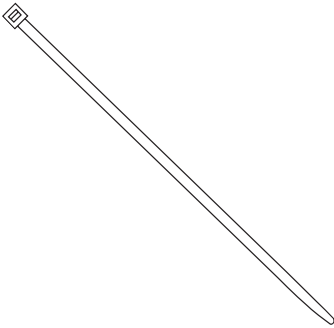

13 x2
Cable tie (11")

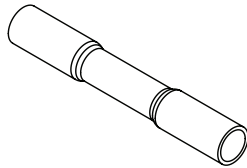

14 x8
Butt Connector

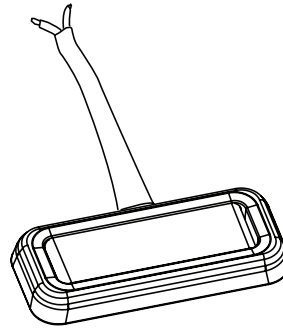

15 x4
LED Lamp

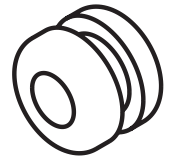

16 x4
Grommet

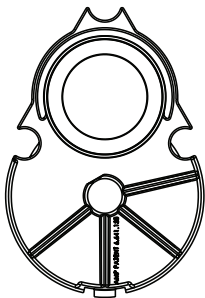

17 x2
Gear Cover

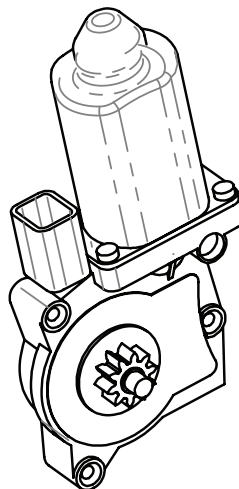

18 x2
Motor

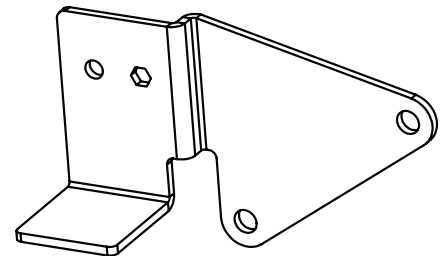

19
Harness Relocation
Bracket

AMP RESEARCH POWERSTEP™ – Ram

On Drivers side of vehicle towards front of body remove harness bracket with 10mm socket or wrench. Remove plug from bracket. And replace with supplied bracket using two of the three factory screws.

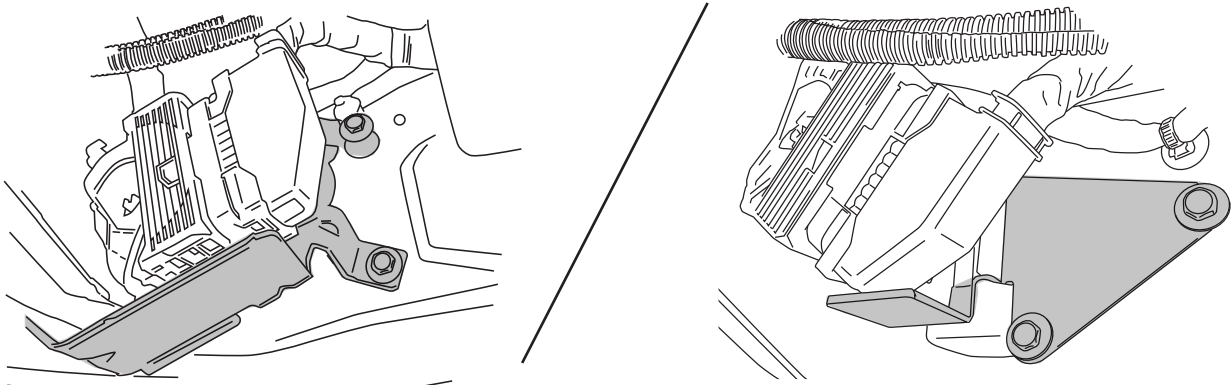

1

Locate mounting points. First and last set of studs on the inner sill. Motor linkage mounts towards the front of the truck and Idler towards the rear. Driver side shown below.

Note: Studs may have excess paint buildup. We recommend using a wire wheel or thread repairing dies to clean excess paint buildup.

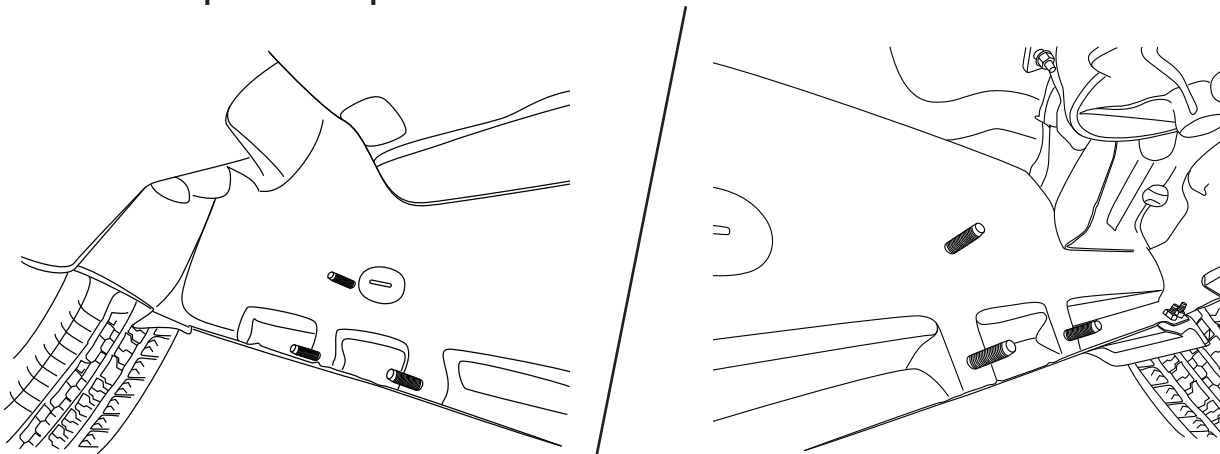

2

Attach motor to linkage. See page 2 for torque specs. Driver side motor orientation shown.

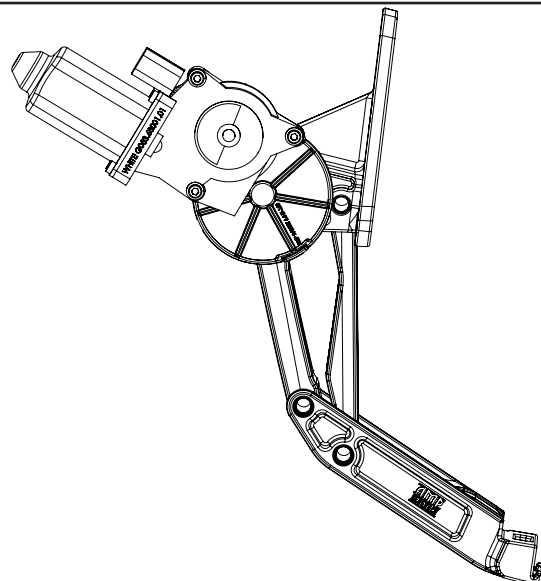

3

AMP RESEARCH POWERSTEP™ – Ram

Slide the front mounting T-nut into position, place the board(1) about 7 1/2 inches from the front edge of the front door. Use fasteners(9) to attach boards, finger tighten only. Align the rear T-nut and bolt it to the rear linkage. Then tighten all 4 fasteners to 10 ft-lbs.

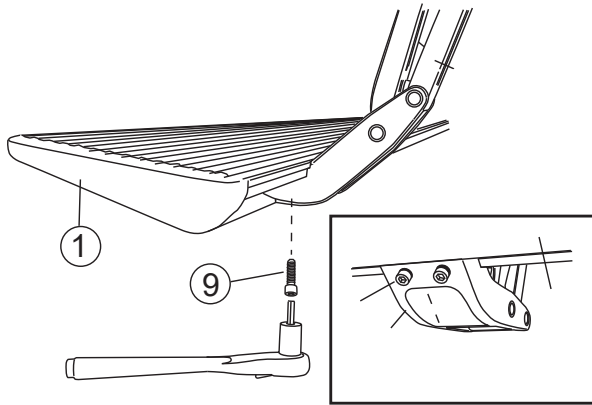

Front of vehicle
←
Driver side shown

Driver Front Door

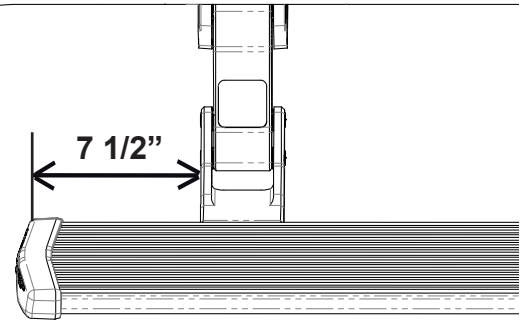

Torque to 10 ft.lbs.

4

Mount drive and Idler linkage assemblies. Repeat for passenger side. Make sure linkages sit square, fully resting on studs before tightening. Torque to 16ft-lbs (22Nm)

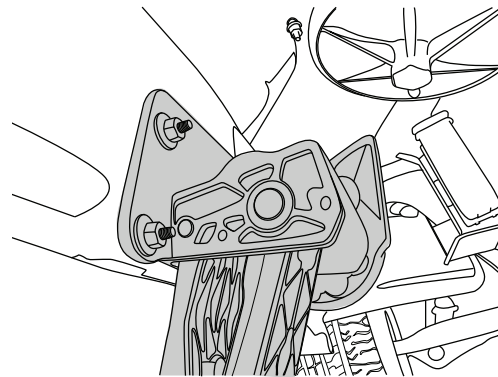
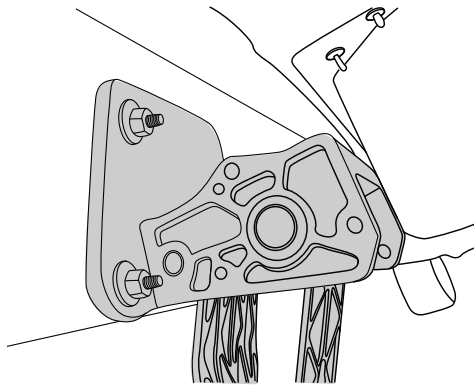

5

Attach wire harness to controller (make sure connector locking tabs fully engage). Mount controller with the two 11" tie wraps(13) to factory conduit, just rearward of battery.

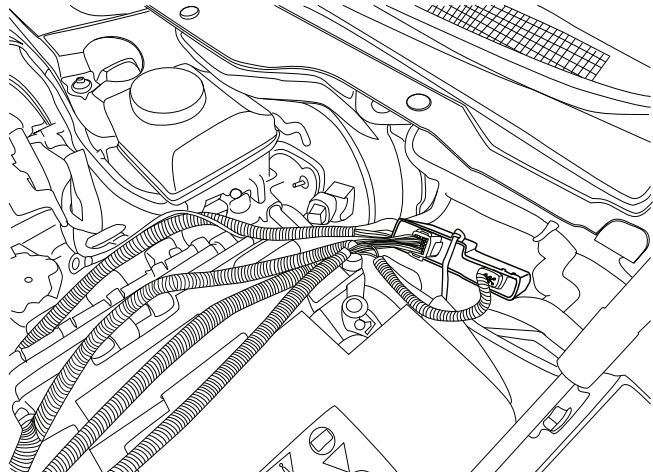
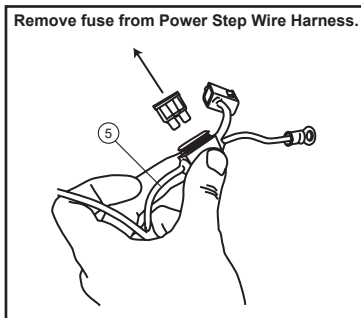

6

AMP RESEARCH POWERSTEP™ – Ram

Connect red and black power leads to battery. Red lead goes to positive.

Secure with cable ties.

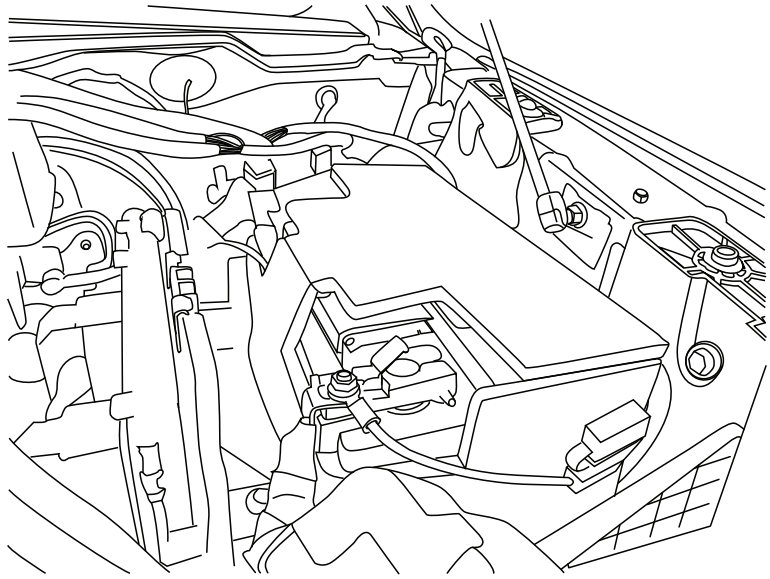

7

Route shorter leg of harness down Driver-side wheel well and longer leg of harness across firewall and down along passenger side wheel well. Attach wire harness with supplied 7" cable ties (12).

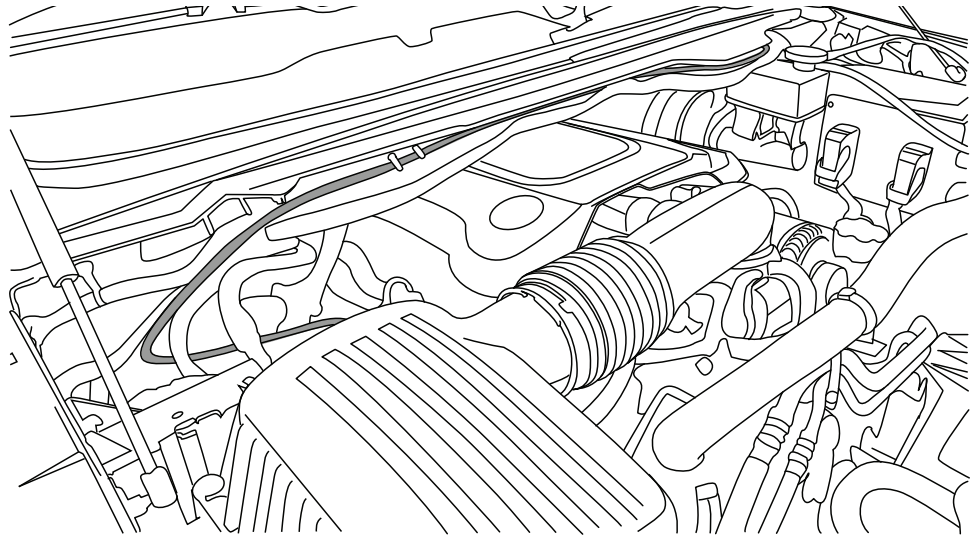

8

Locate rubber boot below steering column. Poke hole to fish trigger wires thru.

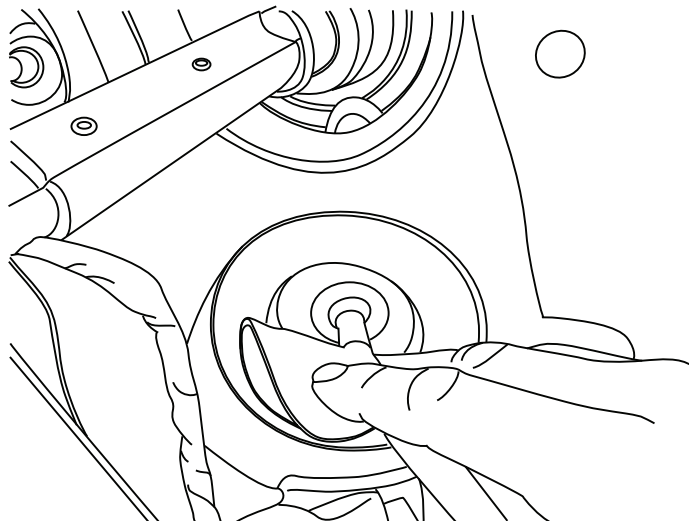

9

Plug OBD (8) to port, tuck wires up and away to prevent snagging when entering and exiting the vehicle.

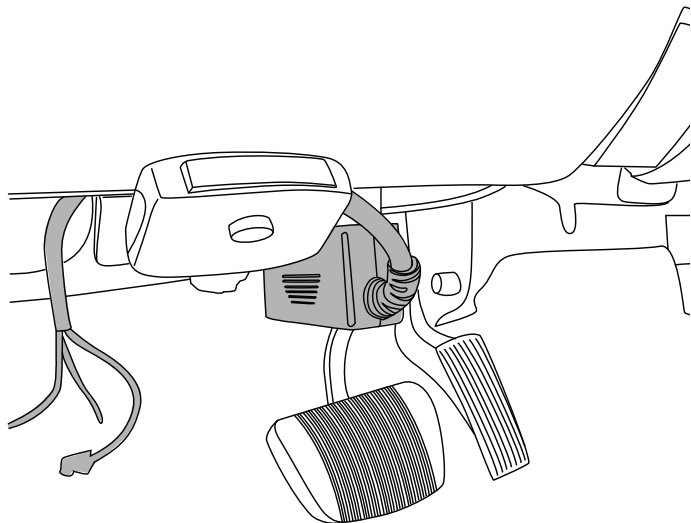

Locate side access cover of dash and remove to gain better access to 2 pin plug for OBD harness installation.

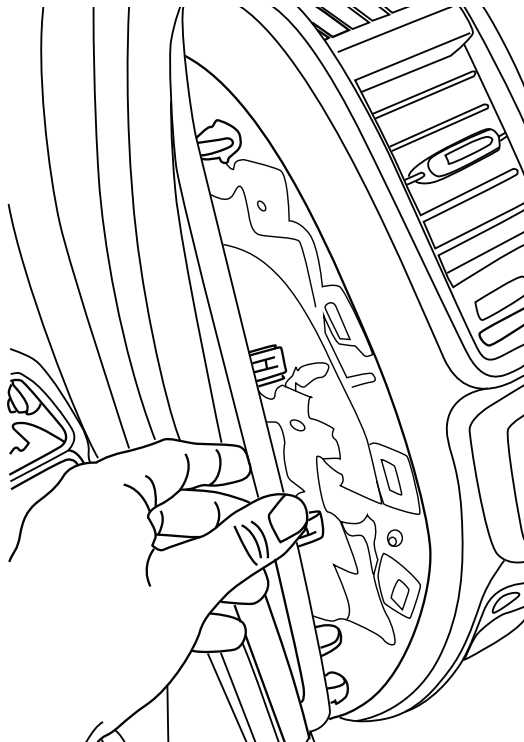

10

11

Locate green block of plugs. And plug 2 pin connector from module into this port.

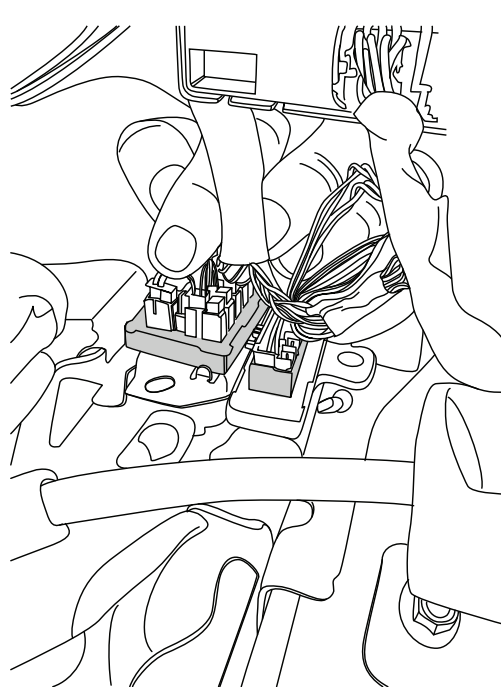
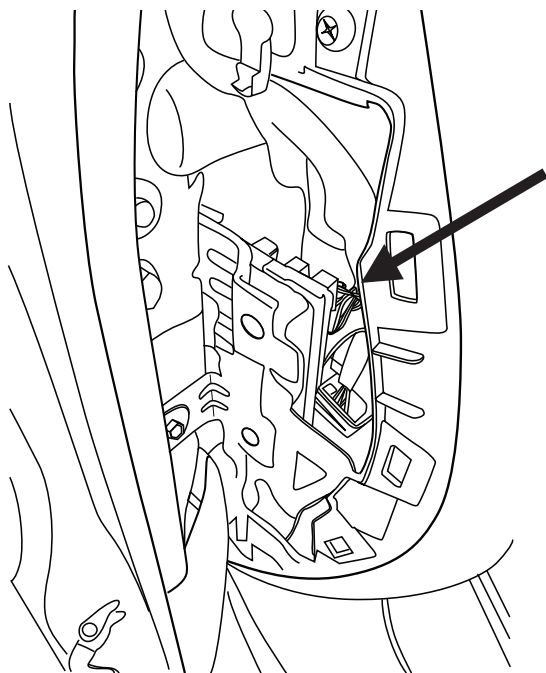

Note: It's best to reach from both sides when installing 2 pin plug. Any open port on green plug can be used.

12

OBD II install: Use Supplied Posi Lock connectors to attach the Plug and Play Module to the Harness. Attach matching colors on the harness to the wires on the module. Plug in module to OBD II port on the vehicle. Secure harness with supplied tie wraps.

Note: If the OBD II pass thru harness (76404-01A) was purchased see install sheet supplied in packaging. The pass through harness allows for an open port for other accessories. See next page for a brief description.

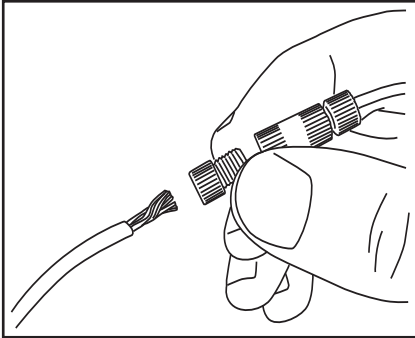

OBD II Connector located below steering column.

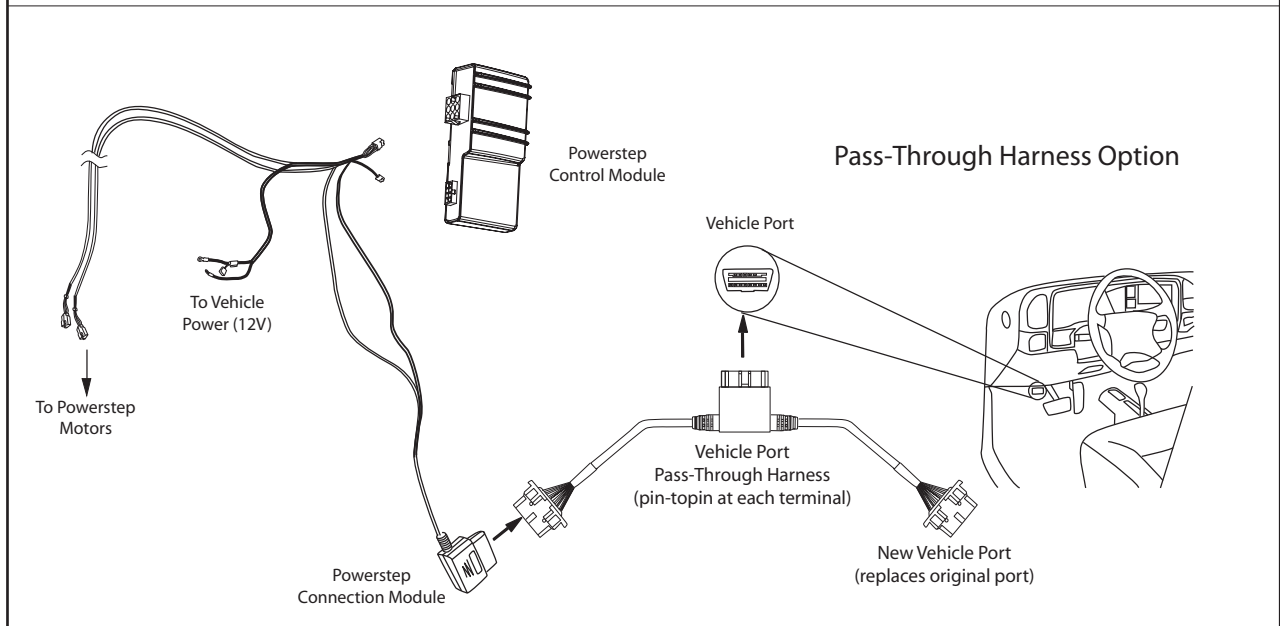
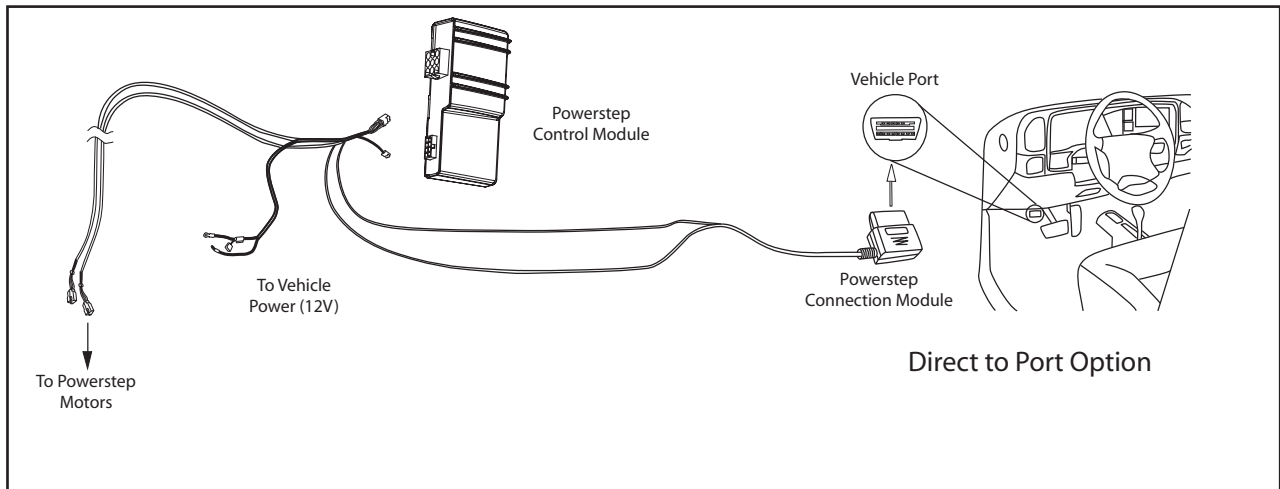
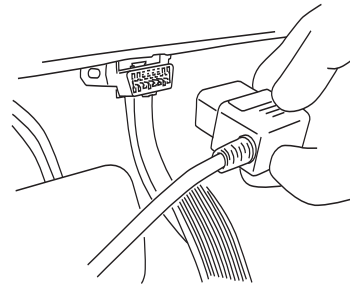

AMP RESEARCH POWERSTEP™ – Ram

On driver side, run Wire Harness leg down and along underside of the vehicle floor and frame to front Drive Linkage. Connect harness to motor and secure harness with tie wraps. Route remainder of wire harness towards rear linkage assembly for LED lights

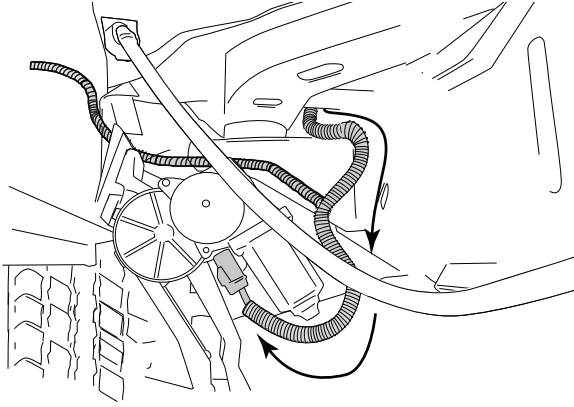

On Passenger Side, run Wire Harness leg down and along underside of the vehicle floor and frame to front Drive Linkage. Connect harness to motor and secure harness with tie wraps. Route remainder of wire harness towards rear linkage assembly for LED lights

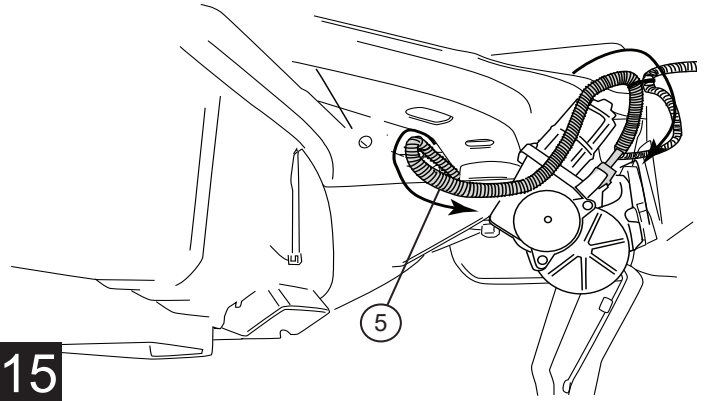

14

15

On each side of the vehicle measure approx. 7" back from front linkage and 8" forward of the rear linkage. Pre drill using an 1/8" drill bit and final drill to 9/32" thru pinch weld at marked locations. Insert grommet into drilled holes. Insert lamp wires through the grommets. (Silicon lube will help wires slip through grommets.) Affix lamp to rocker panel surface. Make sure lamp is affixed to a flat, clean surface.

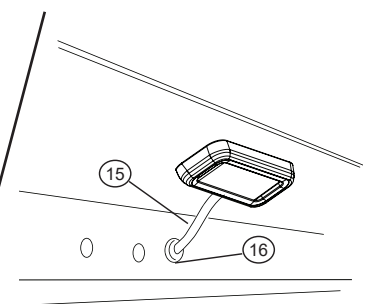
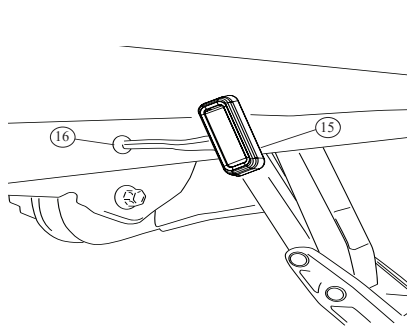
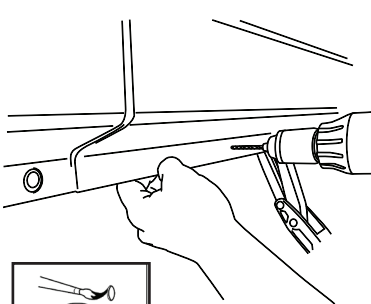

16



Using supplied butt connectors (14) connect the lamp wires. Red to Red, Black to Black. Once Crimped use heat gun to shrink tube. Close and wrap conduit with electrical tape. Secure all loose wires with cable ties. Pull lamp wires upward to avoid any wire snagging.

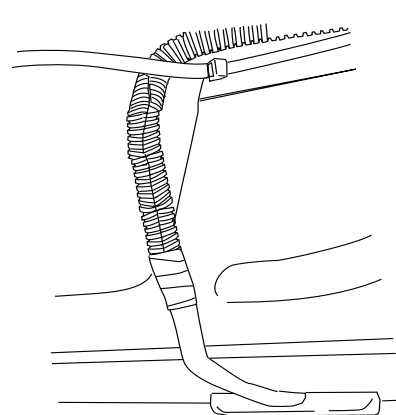
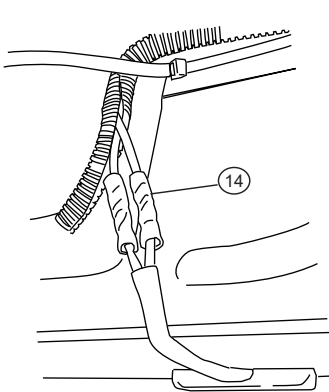

17

Reinstall Fuse and check that all doors activate the Power Step and the LED Lights work when doors open and close. Reinstall any remaining trim panels. **NOTE: Verify front linkage clearance at Frame mounted Vibration Dampener. If linkage contacts Dampener in stowed position loosen bolt at pivot point and rotate up to provide at least 1/2"**

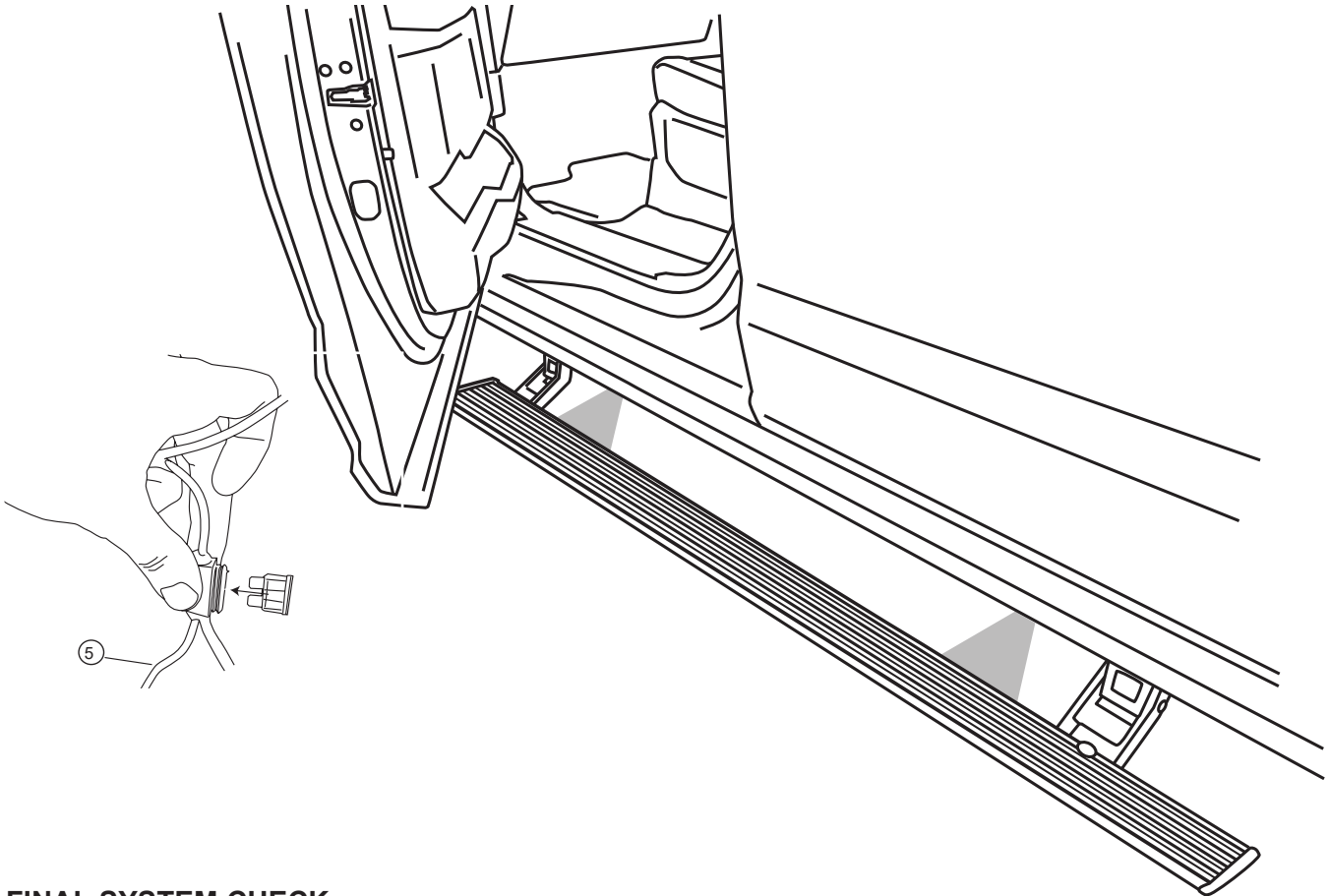

FINAL SYSTEM CHECK

Check that all doors activate the PowerStep and the LED lights work when doors open and close.

NORMAL OPERATION: When the doors open, PowerStep automatically deploys from under the vehicle. When the doors are closed, PowerStep will automatically return to the stowed/retracted position. **Note that there is a 2-second delay before the PowerStep returns to the stowed/retracted position.**

CORRECT OPERATION OF LIGHTS: All four lamps will illuminate upon opening any door of vehicle. Lamps will stay on until restowing of both Power Steps or until 5 minutes has expired with the doors open. When the lights timeout after 5 minutes, they can be reilluminated by closing and opening any door of vehicle.



PowerStep™

Congratulations on your purchase of the genuine AMP Research PowerStep! Here's what you should know...

POWER-DEPLOYABLE RUNNING BOARDS OPERATION: AMP Research PowerStep running boards automatically move when the doors are opened to assist entering and exiting the vehicle.



Automatic power deploy:

The running boards will extend down and out when the doors are opened.

Automatic power stow:

The running boards will return to the stowed position when the doors are closed. There will be a 2-second delay before the running boards move to the stowed position.

Automatic stop:

If an object is in the way of the moving running board, the running board will automatically stop. To reset, clear any obstruction, then simply open and close the door to resume normal operation.



Manually set in the deployed (OUT) position for access to the roof:

The running boards can be manually set in the deployed position by firmly holding the step down with your foot while at the same time closing the door. To resume normal operation, open and close the door.

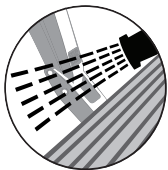

Maintenance: In adverse conditions, debris such as mud, dirt, and salt may become trapped in the running board mechanism, possibly leading to unwanted noise. If this occurs, manually set the running boards to the deployed position and flush the front and rear hinge arms with a high-pressure car wash wand.

Avoid spraying the motors directly. After washing, apply silicone spray lubricant to the hinge pivot pins. Do not apply silicone, wax or protectants like Armor All® to the running board stepping surface.

Caution! Keep hands away when the running board is in motion.