

Assemble brackets as shown. **Spacer to be used on dual exhaust versions only!**
33 ft-lbs / 44 Nm

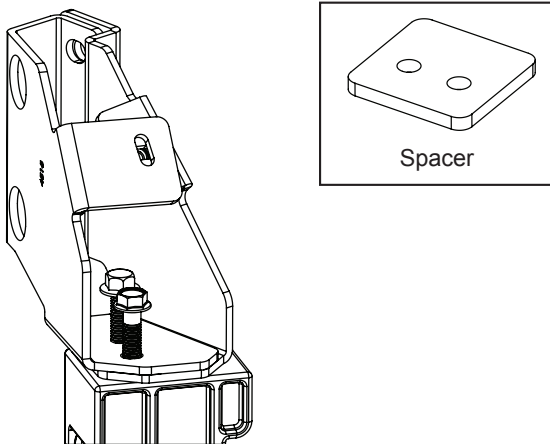

1

Remove support bar with a 21mm deep socket and a 13mm socket or wrench.

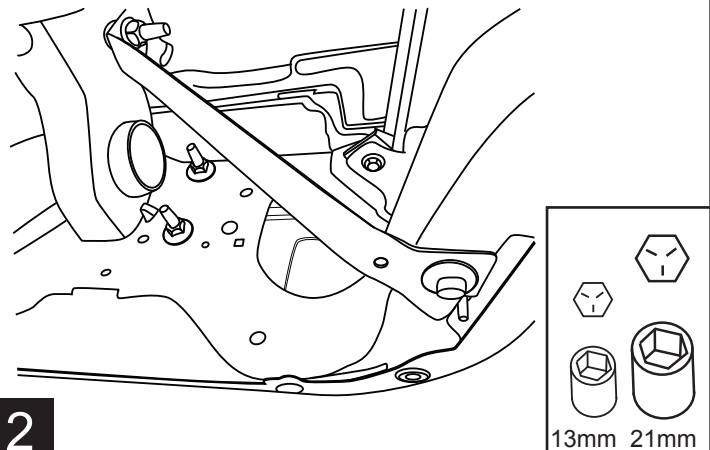

2

Remove 2 nuts and set assembly into position. Reuse factory nuts and Torque to 41ft-lbs/ 55N-m.

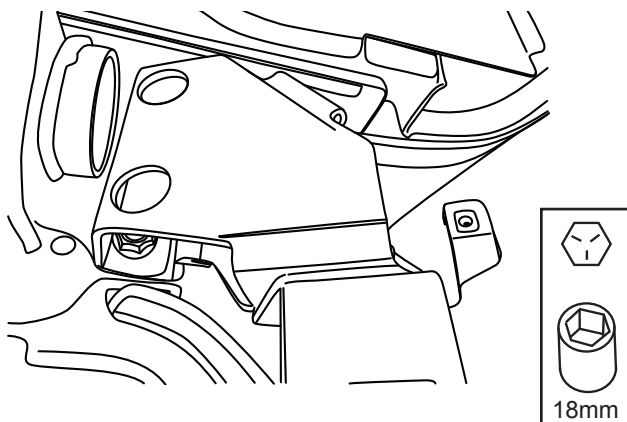

3

Replace brace and slide support strap over stud. Use supplied hardware to bolt strap to assembly. Torque to 41ft-lbs/ 55N-m.

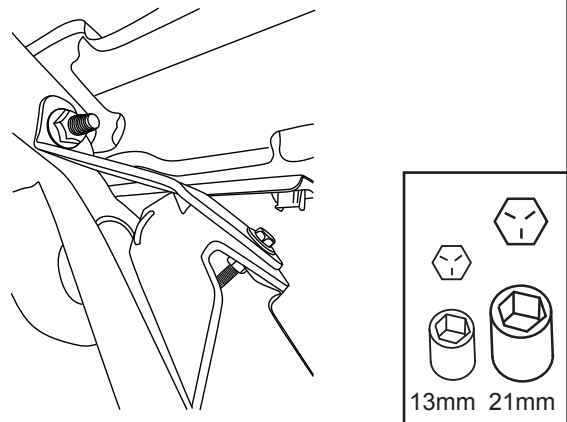

4

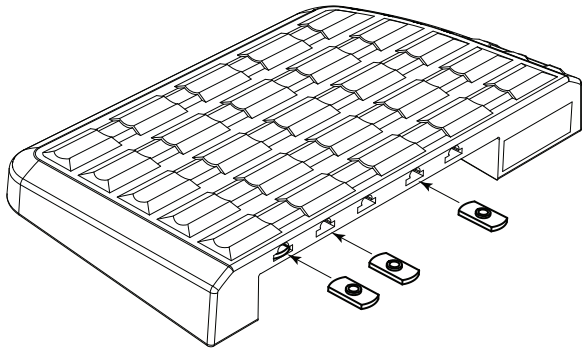

5

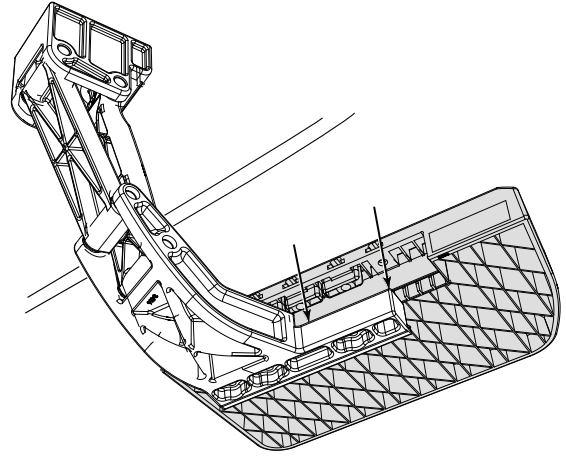

6

6 ft-lbs / 8 Nm

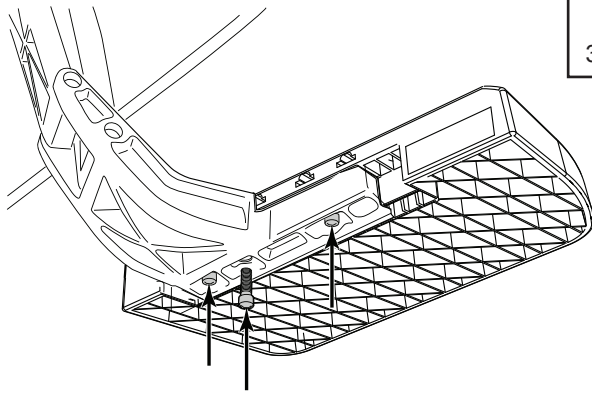

3/16"

7 NOTE: Overtightening may damage step pad

8

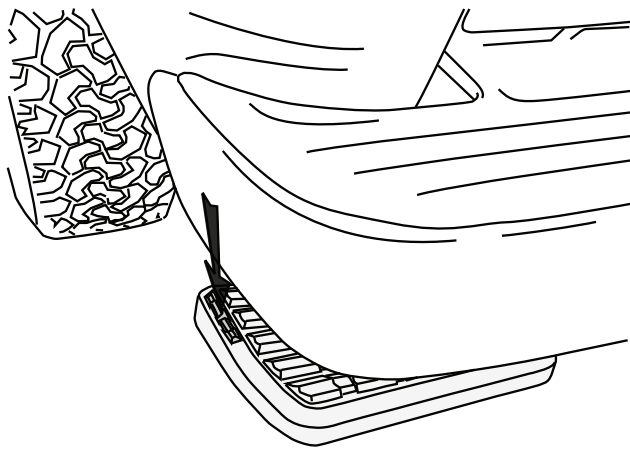
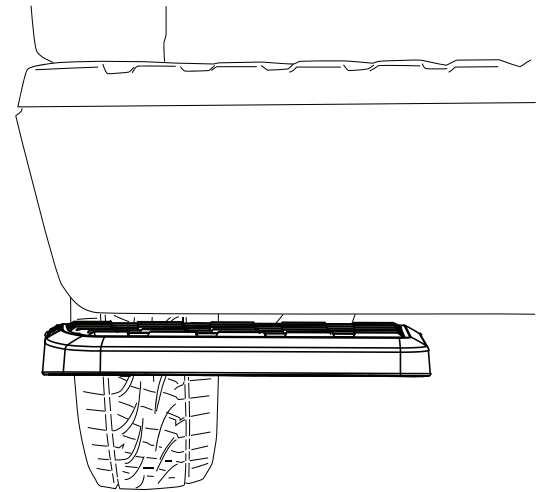

9

Congratulations on the purchase of your AMP RESEARCH BedStep®



Here's what you should know...

OPERATION

- The AMP Research BedStep® is foot operated and deploys and retracts with a nudge of your foot.
- To deploy, press down using your left foot, on the forward outside corner of the step pad.
- To retract, gently kick the underside of the step pad.
- Max Load Capacity: 300lbs.

- Always use appropriate hand holds when stepping up to or down from your truck's cargo bed.

MAINTENANCE TIPS

The step pad surface and linkage arms can be washed with mild soap and water using a soft brush or sponge to dislodge any mud, dirt or accumulated road grime. Rinse with fresh water.

To prevent slipping, avoid applying waxes, lubricants or protectants like Armor All® to the step surface.

ATTENTION!

BEDSTEP SHOULD ALWAYS BE STOWED IN THE RETRACTED POSITION WHEN DRIVING.