

INSTALLATION GUIDE

AMP **Power Step** RESEARCH MADE IN USA

APPLICATION

Jeep Wrangler JT

2020

AMP Part

75135-01A

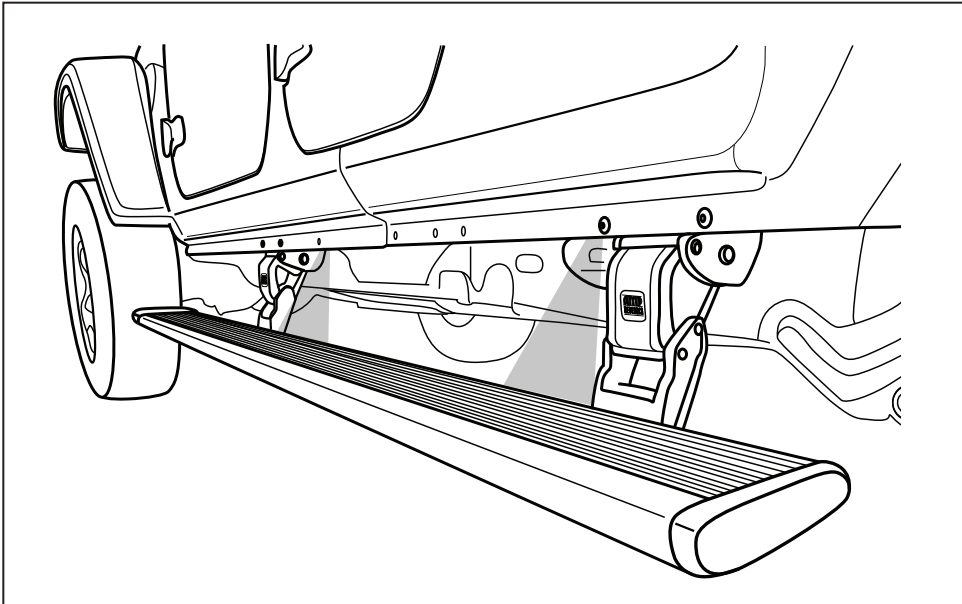

INSTALLATION TIME

3-5 Hours

Professional installation recommended

SKILL LEVEL



4= Experienced

TOOLS REQUIRED

- Safety goggles
- Measuring tape
- 10 mm socket
- 13 mm socket
- 1/2" socket
- Ratchet wrench and extension
- Wire crimpers
- Wire stripper / cutter
- 3/16" hex key wrench (allen wrench)
- 4mm hex key wrench (allen wrench)
- Electrical tape
- Weather proof caulking (silicone sealer)
- Silicone spray

EXPLODED VIEW

- Motor
- Hex Head Bolt

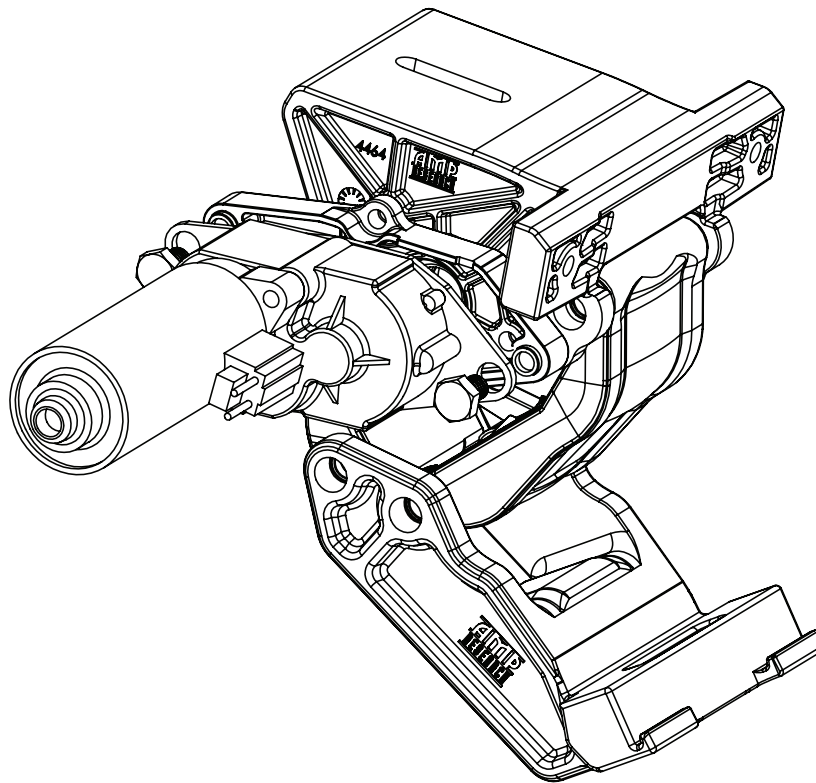

CAUTION: HANDLE WITH CARE.

To ensure our customers receive all components with full integrity, we pack the motors separate from their linkage assemblies. This requires that the installer position and fasten the motor before continuing with the install. Please follow the instructions below and handle the assembly carefully.

CAUTION: Dropping the assembly or any excessive impact MAY cause damage to the motor.

Instructions:

1. Position the gear cover in place as shown if not already in place.
2. Seat motor into position on the three mounting bosses. This may require an adjustment of the gear by moving the swing arms.
3. After seating into place, fasten the motor with the three motor mount screws with 4mm Hex Head. Tighten screws to 36 in-lbs (4N-m). **Do not over torque.**

AMP RESEARCH POWERSTEP™ – Jeep Wrangler JL

- End cap left (x1)
- End cap right (x1)
- T-nut insert (x2)
- Socket cap screw (x2)
- Nut plate (x2)

① x2
Step assembly

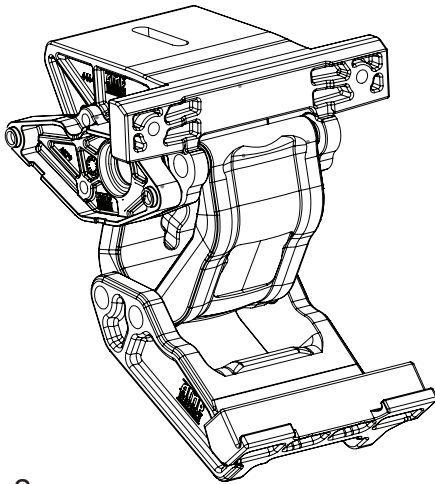
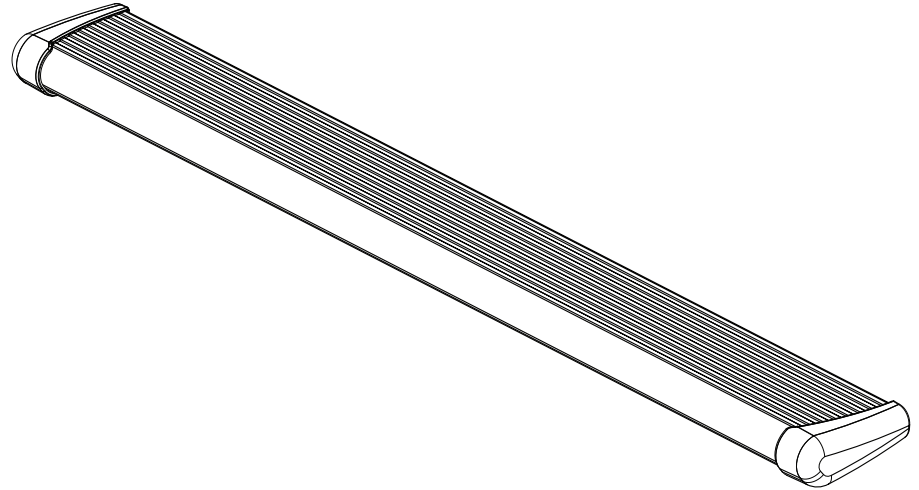

③ x2
Motor Linkage assembly
Driver

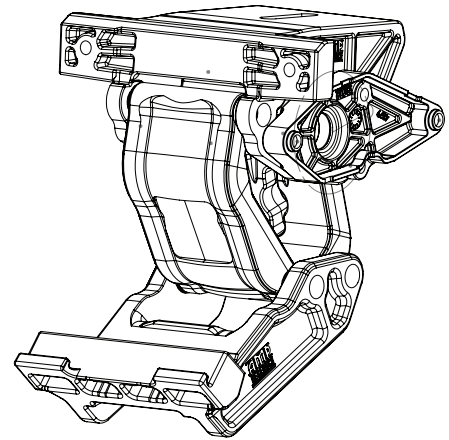

④ x2
Motor Linkage assembly
Passenger

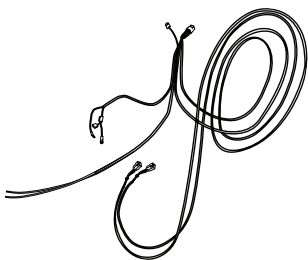

⑤
Wire harness

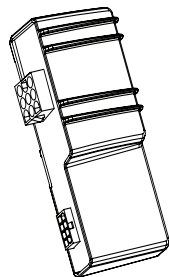

⑥
Controller XTA



⑦ x4
Posi Tap

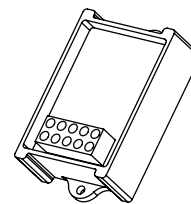

⑧
Door Trigger
Module

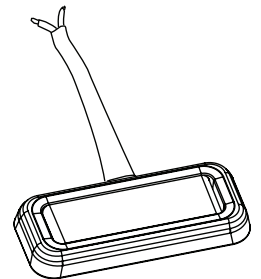

⑨ x4
LED Lamp
Module

AMP RESEARCH POWERSTEP™ – Jeep Wrangler JL

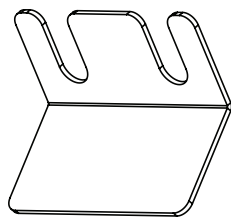

10 x4
LED Light Bracket

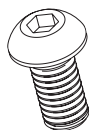

11 x8
M8 Button Head Bolt

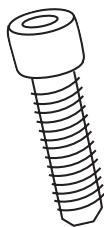

12 x8
Socket Cap Screw

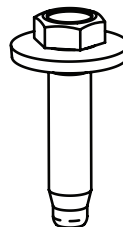

13 x4
M8 Hex Bolt w
Conical washer



14 x8
Washer

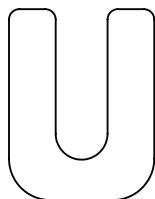

15 x2
Shim Spacer

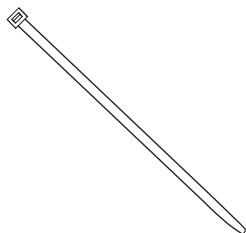

16 x20
Cable tie (7")

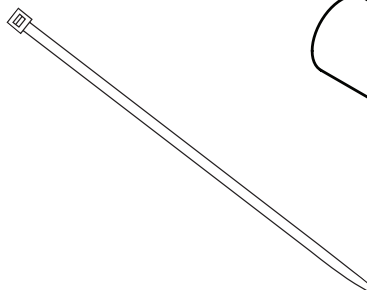

17 x2
Cable tie (11")

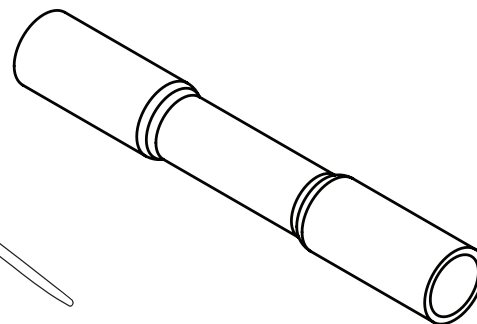

18 x11
Butt Connector

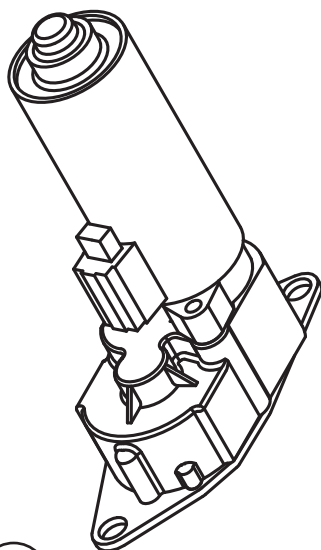

19 x4
CRH Motor



20 x12
Cinch Fastener

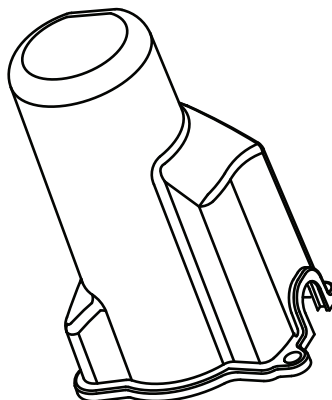

21 x4
Motor Cover

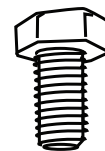

22 x8
M8 Head Hex Bolt

Mounting positions circled for front and rear linkage mounting points. Driver side shown.

Note: Motors face forward on each side.

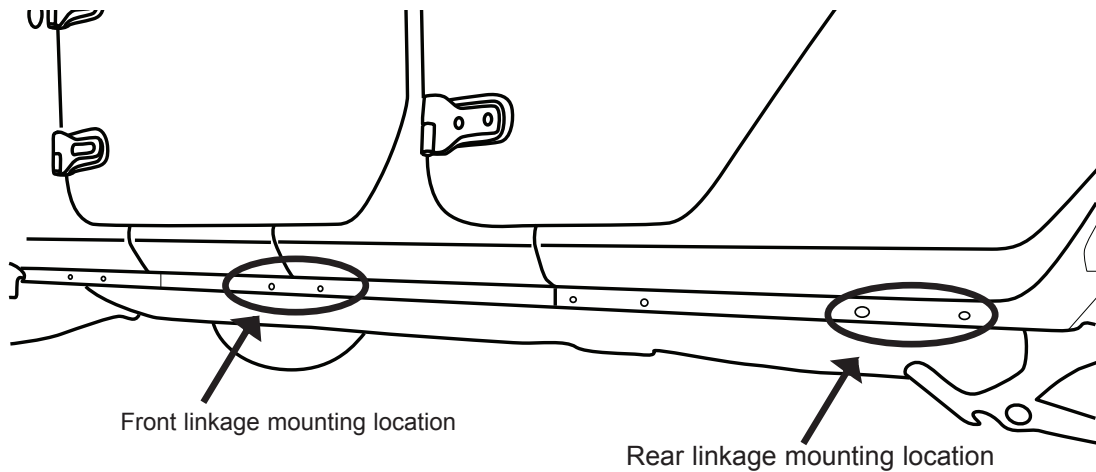

1

Install Rear Drive Linkage: Locate 2nd set of holes forward. Using supplied button head screws(11) and washers(14) assemble linkage to pinch weld. Before tightening, slide Light mounting bracket(10) in forward mounting hole. Next use supplied hex bolt with conical washer(13) through bottom threaded insert in body. Torque fasteners to 16 ft-lbs (22N-m). Repeat linkage installation for passenger side.

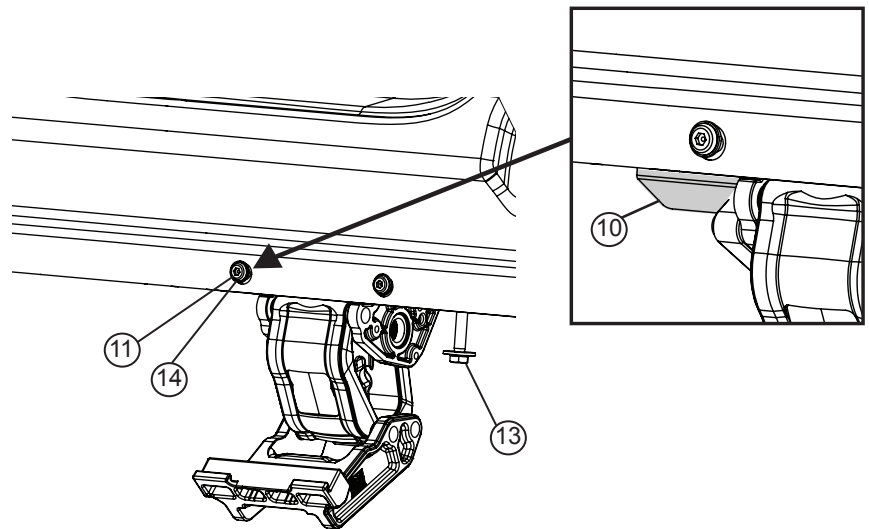

2

Install Front Drive Linkage: Locate next set of mounting holes forward. Note drive linkage with motor mount facing towards front of vehicle. . Using supplied button head screws(11) and washers(14) assemble linkage to pinch weld. Before tightening, slide Light mounting bracket(10) in Rearward mounting hole. Next use supplied hex bolt with conical washer(13) and shim (15) through bottom threaded insert in body. Torque fasteners to 16 ft-lbs (22N-m). Repeat linkage installation on passenger side.

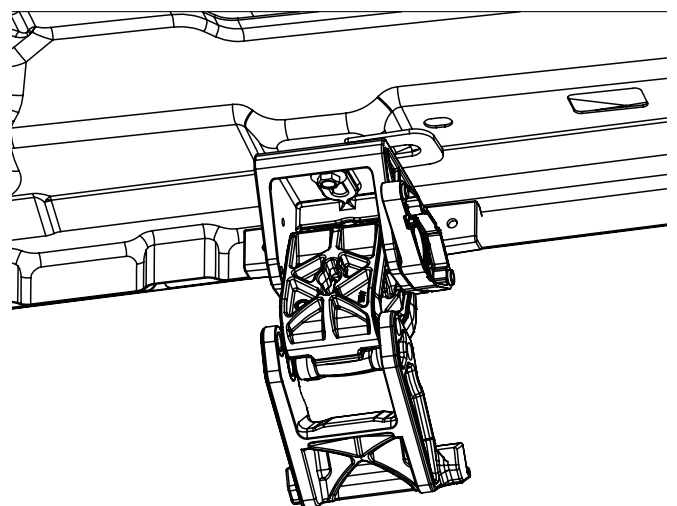

3

AMP RESEARCH POWERSTEP™ – Jeep Wrangler JL

Mount step extrusion to linkage assemblies. Line up T nuts in step assembly with slots in lower mounts of linkage assemblies. Fasten loosely to allow for adjustments.

Line up step extrusion with rear fender well. Tighten and torque 4 socket cap screws(12) with 3/16" allen wrench. Torque to 10 ft-lbs. (13.5N-m)

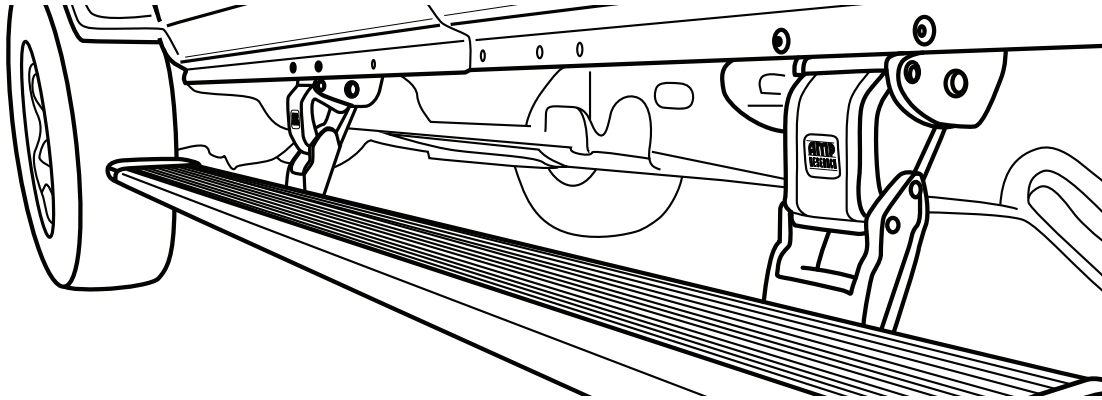

4

Slide motor assembly onto drive shaft and mounting bosses of driving linkage assembly. Use supplied M8 bolts.

Torque to 8 ft-lbs(11N-m)

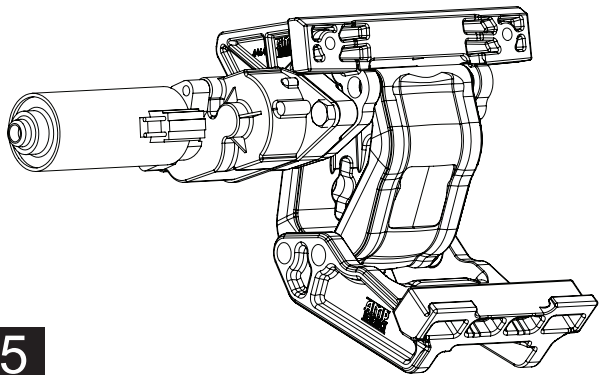

5

Remove fuses from Power Step Wire Harness.

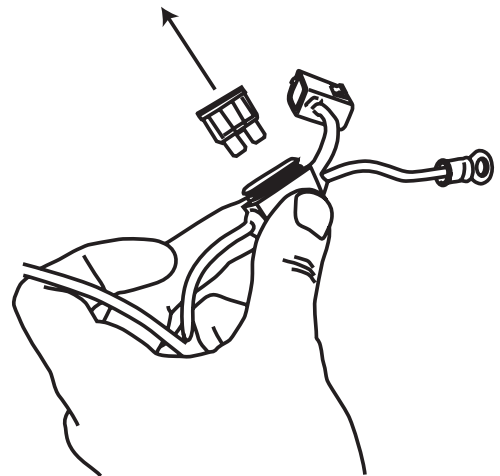

6

Prepare large tie-wraps for mounting Power Step Controller. Loosely loop tie-wraps around large bundle of wires behind battery in engine compartment. Insert controller into tie-wrap loops and cinch down securely. The tie-wraps should cinch down into channels on controller surface. Connect power leads from Controller, Red to positive battery terminal and Black to the vehicle body ground as shown.

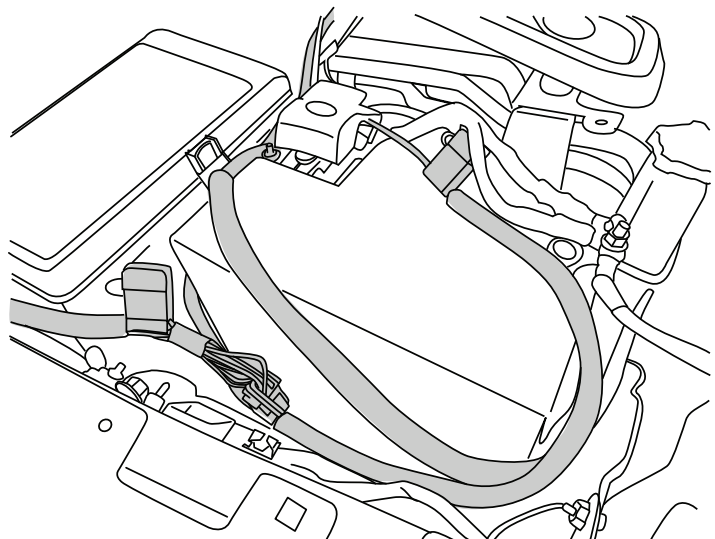

7

AMP RESEARCH POWERSTEP™ – Jeep Wrangler JL

Splice Power Step trigger wires into the Door Ajar wires with provided Posi-Tap™ splicers. The Power Step trigger wires color coordinate with the factory Door Ajar wires. Follow the steps below to correctly splice wires.

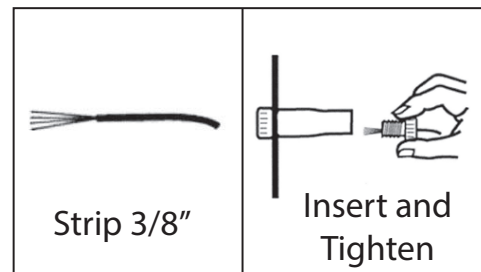
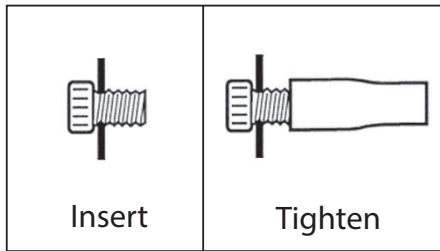

8

Route the two Wire Harness legs down over the wheel wells toward Motor Linkages, long leg across to the driver side. Secure harness with tie wraps.

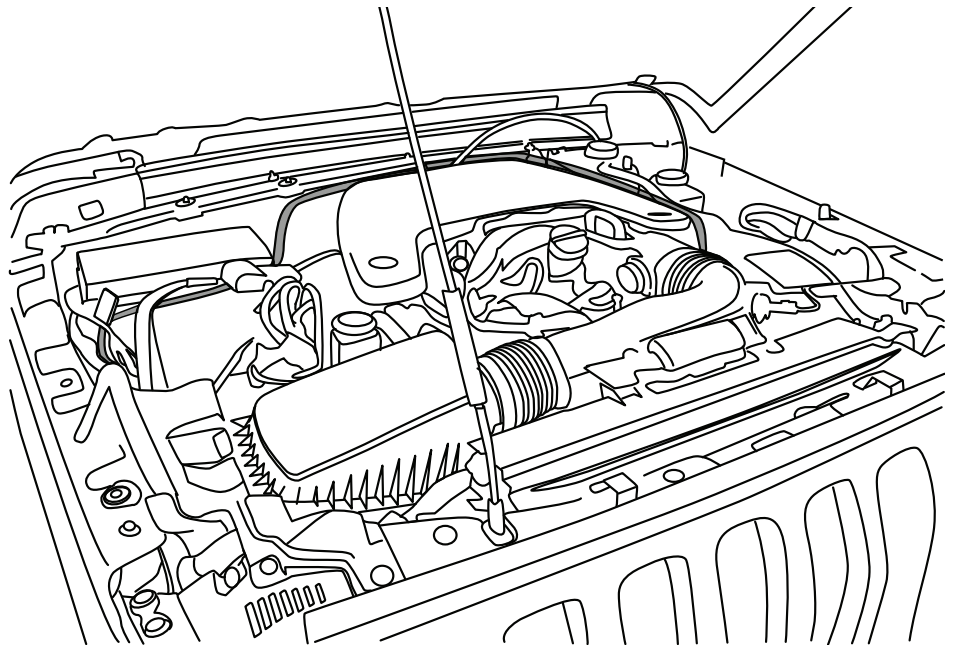

9

Remove sill plate cover. Remove grommet under floor and route trigger wires and power wire thru grommet.

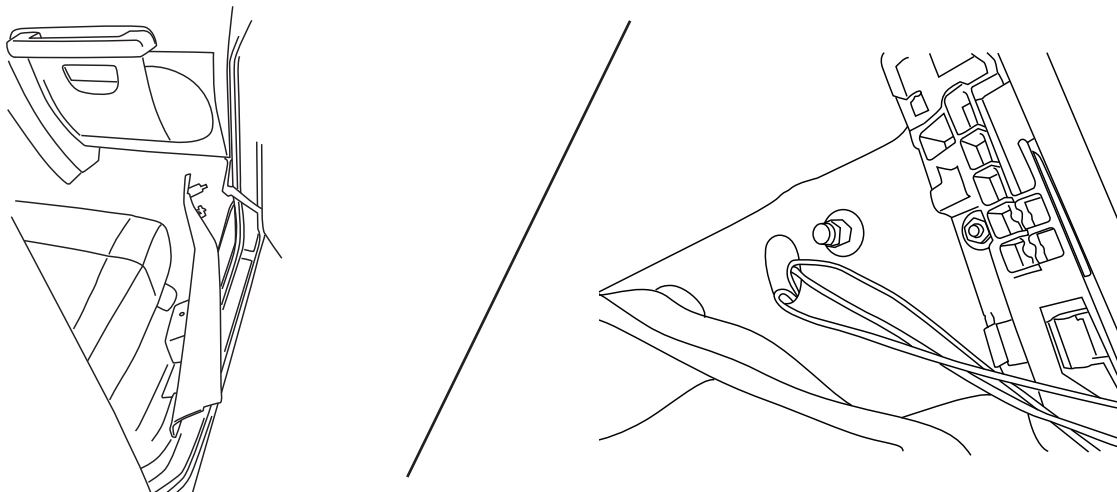

10

Mount door trigger module to wire harness in kick panel area. Using a 10mm socket remove ground lug and connect ground to body. Using supplied butt connectors connect red wire on harness to red wire (Pin1) on module. Next connect Purple with black stripe wire on harness to purple with black stripe from module (pin 6). Lastly connect Purple from harness to purple on module (Pin 7). See next step for trigger wire assembly.

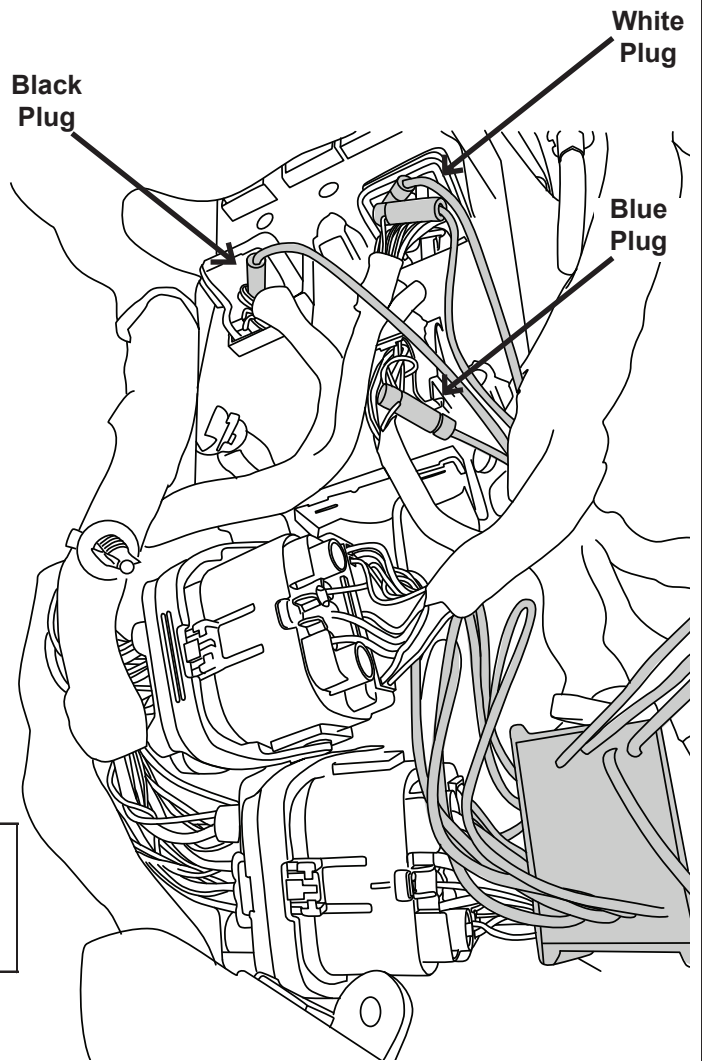

| Description | Wire Color | Pin locations | Wire Color | Description |
|--------------------|------------|---------------|------------|-----------------------|
| Positive Supply | Red | 1 6 | PRP/BLK | Driver Side Output |
| Ground | BLK | 2 7 | PRP | Passenger Side Output |
| Driver Front Input | PRP | 3 8 | WHT | Passenger Front Input |
| Driver Rear Input | GRY | 4 9 | YEL | Passenger Rear Input |
| Not Used | - | 5 10 | - | Not Used |

AMP Door Trigger Module pin out

11

Locate the white connector panel against passenger side kick panel area. Locate three connectors as shown below and connect powerstep trigger wires as indicated in the chart. Match pin locations called out in previous step.

| Door Ajar Wire | Vehicle Wire Color/Stripe Color | Pin location on AMP Door Trigger Module | Vehicle BCM Connector Color |
|----------------|---------------------------------|---|-----------------------------|
| Driver Front | Violet | 3 | White |
| Pass. Front | Violet/White | 8 | Blue |
| Driver Rear | Violet/Grey | 4 | White |
| Pass. Rear | Violet/Yellow | 9 | Black |

Note: Plug reassembly is critical. Lever Arm of plug must be rotated completely locked in the open position to engage properly!

12

AMP RESEARCH POWERSTEP™ – Jeep Wrangler JL

On driver side, run Wire Harness leg down and along underside of the vehicle floor and frame to front Drive Linkage. Connect harness to motor and secure harness with tie wraps. Route remainder of wire harness towards rear linkage assembly for LED lights. Repeat step on passenger side.

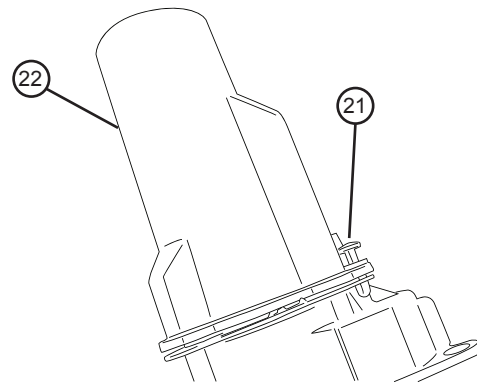
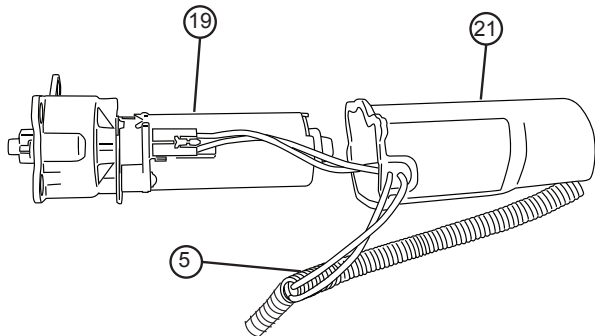

13

Affix LED lamp (9) to LED Bracket (10) as shown. Affix LED light bracket assembly to rail. Mount front light rearward of front linkage and mount rear light just forward of rear linkage.

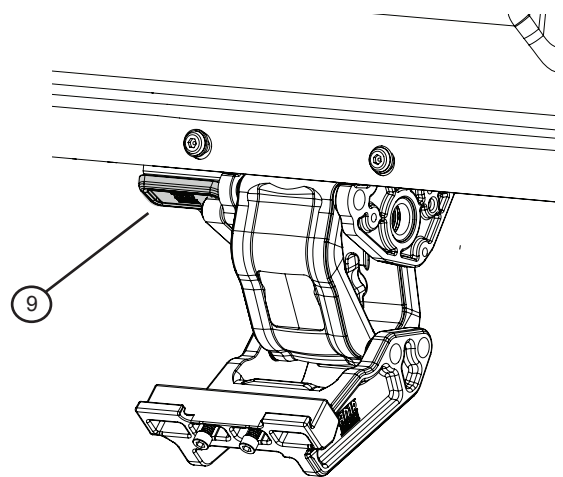
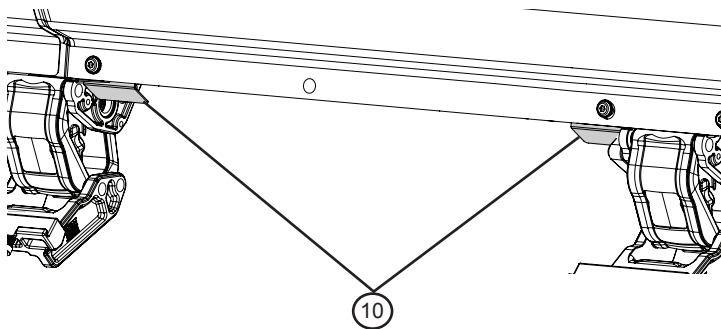

14

Using supplied butt connectors, connect the lamp wires. Red to Red, Black to Black. Once Crimped use heat gun to shrink tube. Close and wrap conduit with electrical tape. Secure all loose wires with cable ties. Pull lamp wires upward to avoid any wire snagging.

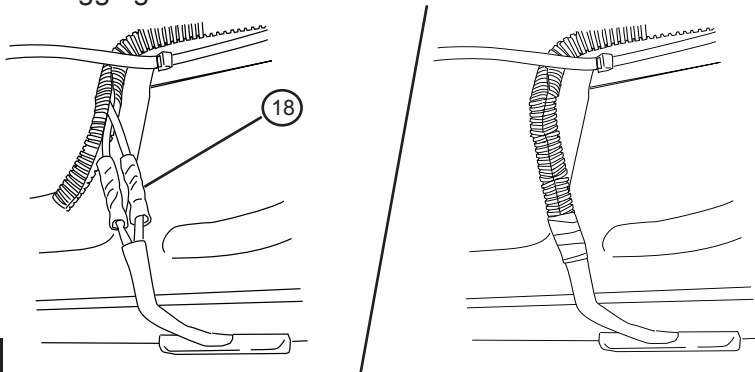

15

Reinstall Fuses from Powerstep Wire Harness.

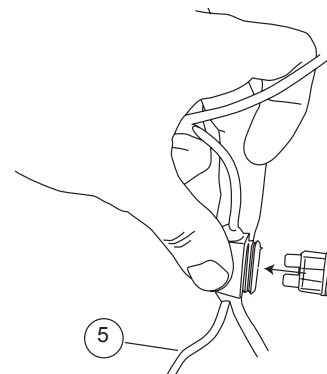

16

Check that all doors activate the Power Step and the LED Lights work when doors open and close. Reinstall any remaining trim panels.

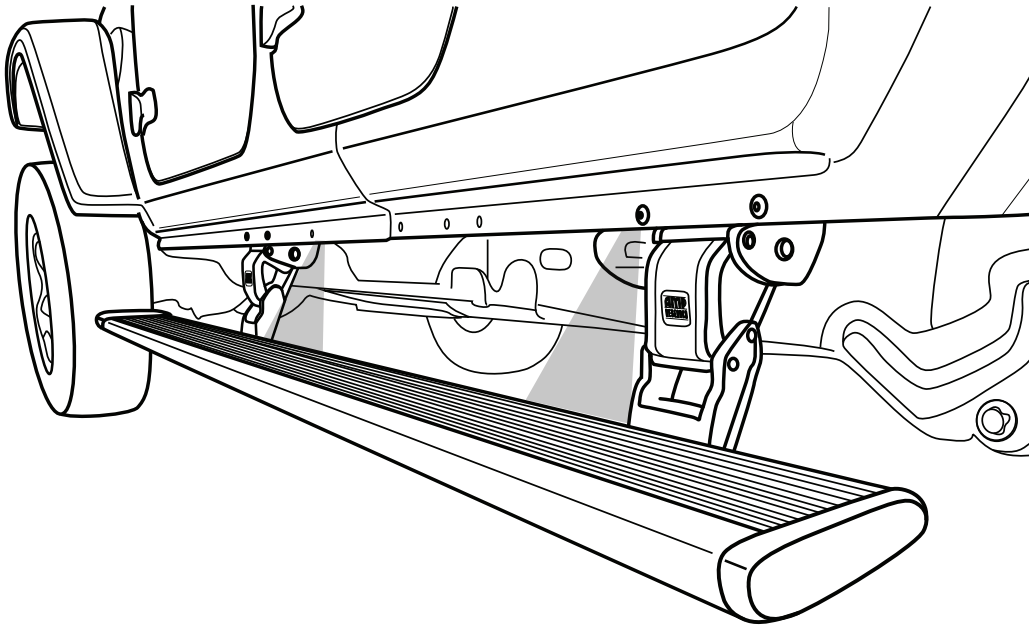

FINAL SYSTEM CHECK

Check that all doors activate the PowerStep and the LED lights work when doors open and close.

NORMAL OPERATION: When the doors open, PowerStep automatically deploys from under the vehicle. When the doors are closed, PowerStep will automatically return to the stowed/retracted position. **Note that there is a 2-second delay before the PowerStep returns to the stowed/retracted position.**

CORRECT OPERATION OF LIGHTS: All four lamps will illuminate upon opening any door of vehicle. Lamps will stay on until restowing of both Power Steps or until 5 minutes has expired with the doors open. When the lights timeout after 5 minutes, they can be reilluminated by closing and opening any door of vehicle.

POWER-DEPLOYABLE RUNNING BOARDS OPERATION: AMP Research PowerStep running boards automatically move when the doors are opened to assist entering and exiting the vehicle.



Automatic power deploy:

The running boards will extend down and out when the doors are opened.

Automatic power stow:

The running boards will return to the stowed position when the doors are closed. There will be a 2-second delay before the running boards move to the stowed position.

Automatic stop:

If an object is in the way of the moving running board, the running board will automatically stop. To reset, clear any obstruction, then simply open and close the door to resume normal operation.



Manually set in the deployed (OUT) position for access to the roof:

The running boards can be manually set in the deployed position by firmly holding the step down with your foot while at the same time closing the door. To resume normal operation, open and close the door.

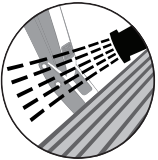

Maintenance: In adverse conditions, debris such as mud, dirt, and salt may become trapped in the running board mechanism, possibly leading to unwanted noise. If this occurs, manually set the running boards to the deployed position and flush the front and rear hinge arms with a high-pressure car wash wand.

Avoid spraying the motors directly. After washing, apply silicone spray lubricant to the hinge pivot pins. Do not apply silicone, wax or protectants like Armor All® to the running board stepping surface.

Caution! Keep hands away when the running board is in motion.