

ASSEMBLY & INSTALLATION GUIDE



BedXTender^{HD} MAX

APPLICATION

Deep Bed Truck (F-150 & Tundra)
Large Truck, Universal (Full-size trucks, wide beds)
Small Truck, Universal (Mid-size and small trucks, small beds)

PART

74813-00A (Silver)	74813-01A(Black)
74814-00A (Silver)	74814-01A(Black)
74811-00A (Silver)	74811-01A(Black)

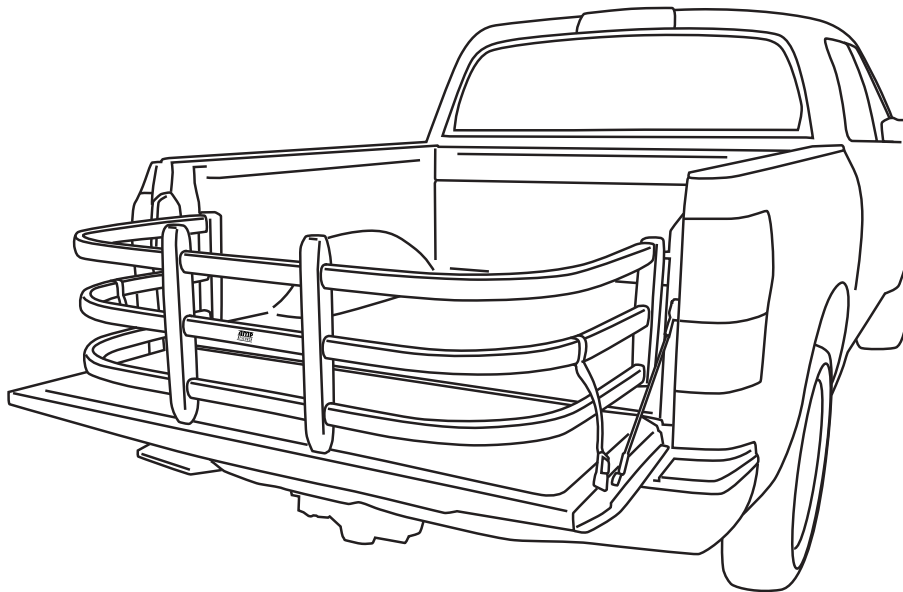

INSTALLATION TIME

1 Hour

SKILL LEVEL



1= Easy

TOOLS REQUIRED

Phillips screw driver
Torx T-25 driver
Power drill
9/64" drill bit
Center punch
Supplied templates
Soapy Water

BEDXTENDER HD™ shown assembled and installed on truck.

Remove contents from box and check for damage.

Verify all parts against parts list.

Read and understand instructions completely before attempting assembly and installation.

Invented, engineered and manufactured exclusively by AMP Research in the USA. May be covered by one of the following patents:

5,700,047; 6,113,173; 6,402,215; 6,805,392; 7,063,366; 7,393,035; 7,654,598; 7,681,935; 7,841,638

PARTS LIST AND HARDWARE IDENTIFICATION

① x2
Quick Mount
Bracket Set

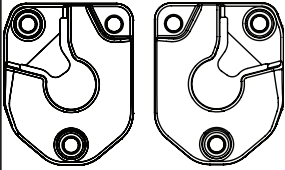

② x6
Phillips head
screw
(included in 74608-01A)

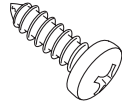

③ x12
PT-Screw

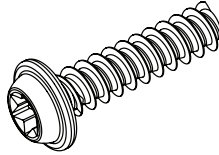

④ x4
Bumper

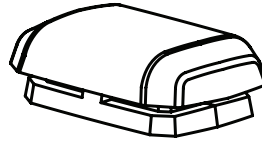

⑤ x2
Strap Buckle Assembly

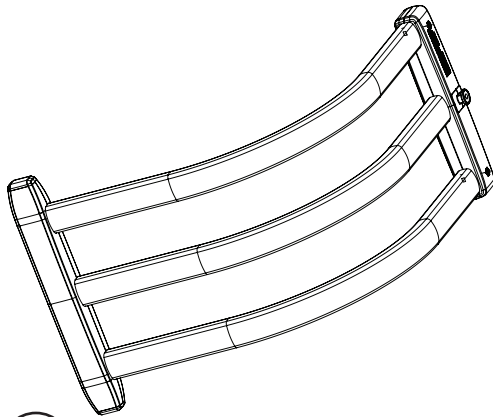
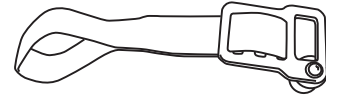

⑥ x2
Silver: (Small)
Black: (Small)
Silver: (Deep)
Black: (Deep)
Silver: (Large)
Black: (Large)
Pivot Upright Assembly

⑦ x2
(Small/Narrow)
(Large/Deep)
Bumper Upright Outer



⑧ x2
(Small/Narrow)
(Large/Deep)
Bumper Upright Inner



⑨ x3

(Small Silver)
(Small Silver with LOGO)
(Small Black)
(Small Black with LOGO)
(Large/Deep Black)
(Large/Deep Black with LOGO)
(Large/Deep Silver)
(Large/Deep Silver with LOGO)
Center Tube

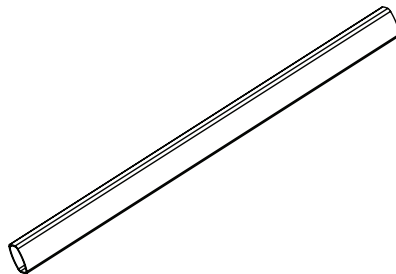

⑩ x2
Strap latch insert
Kit number 74603-01A
(Only provided on
Deep Bed/Small kits)

⑪ x2
Socket cap screw
(Only provided on
Deep Bed/Small kits)



AMP RESEARCH BEDXTENDER HD™

ADDITIONAL MOUNTING KITS

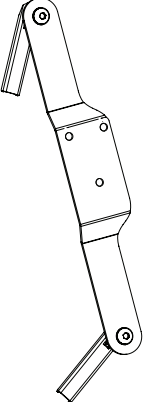
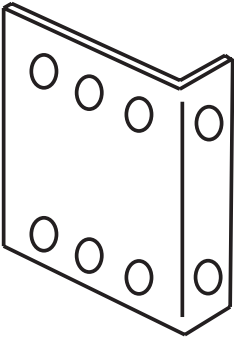
	DESCRIPTION	APPLICATION	
	<p>No-Drill Mounting Bracket Kit – Ford F-Series</p> <p>OPTIONAL</p>	<p>2004+ F-150 2008+ F-250 2008+ F-350</p>	
	<p>L-Bracket Mounting Kit</p> <p>REQUIRED ON SOME APPLICATIONS TO COMPLETE INSTALLATION</p>	<p>GM S-Series Mazda B-Series Nissan Pickup Toyota Pickup (Pre 2005 models)</p>	

UNIVERSAL MOUNTING BRACKET INSTALLATION

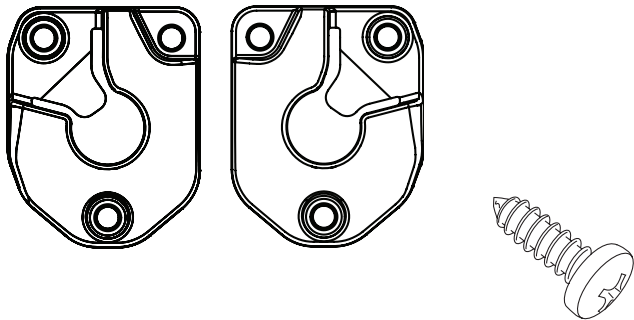

1 x2

Quick Mount
Bracket

2 x6

Phillips head
screw

Cut out supplied template and tape to the D-D-pillar as shown. Using a center punch, make holes as specified by the template.



1

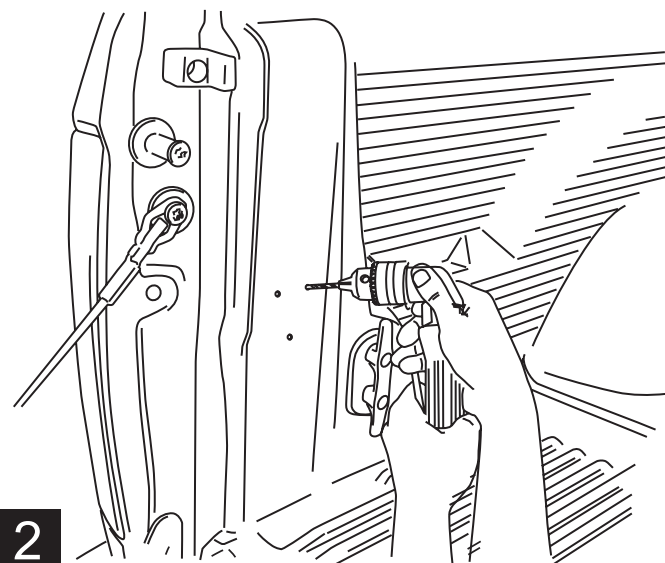

2

Using a power drill and 9/64" drill bit, drill through the sheet metal. If equipped with a bedliner, drill through bedliner.

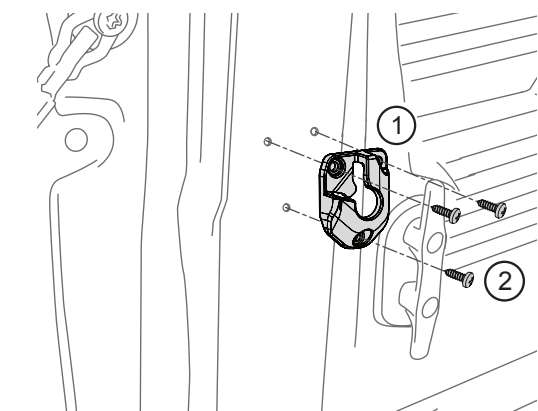

3

Fasten mounting brackets using the supplied self-tapping Phillips screws and torque to 30 in. lbs. If equipped with a bedliner, install mounting brackets over bedliner.

NOTE: If bedliner has contours that may prohibit a flat, solid mounting surface, cut out a rectangular section to clear the bracket and mount the bracket directly to the metal D-pillar.

BED X-TENDER ASSEMBLY

Measure 7" from each end of the three center tubes and mark with tape. **Tape is to be used as a reference point**

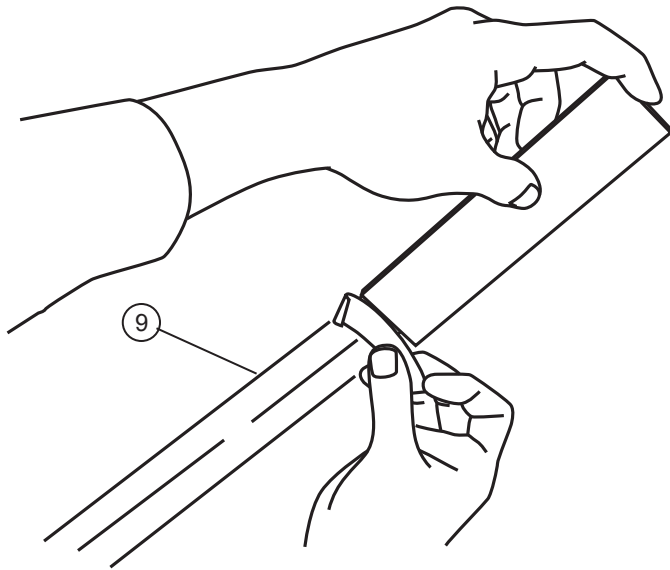

1 Note: Template located on inside of box.

Slide 3 center tubes into the open ends of the bent tubes as shown. Insert center tube with logo into the center tube.

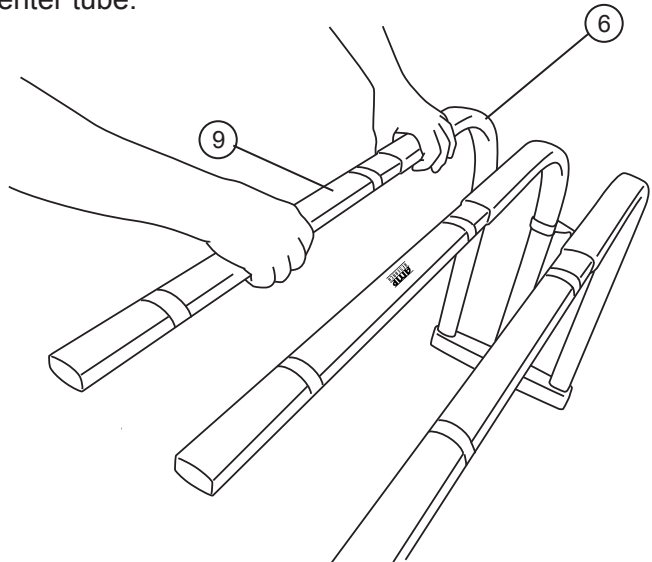

2

Connect the two halves. Make sure there is at least 3" overlap with the bent tubes on each side.

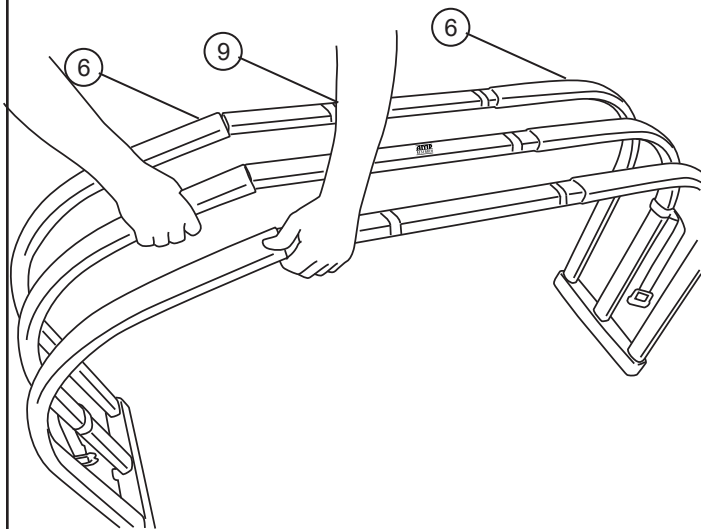

3

Adjust the width of the BEDXTENDER by placing the pivots into the mounting brackets. To keep overlap constant, adjust each tube so that the gap between the edge and the tape is the same.

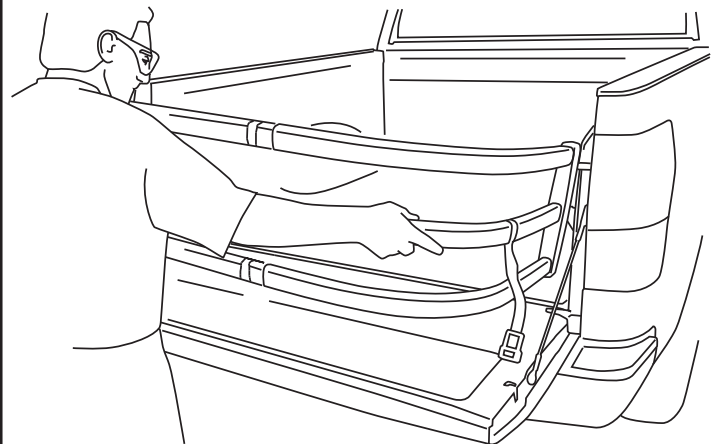

4

BED X-TENDER ASSEMBLY – CONTINUED

Attach plastic upright around the tube juncture, placing rubber bumpers into the two ends of the upright.

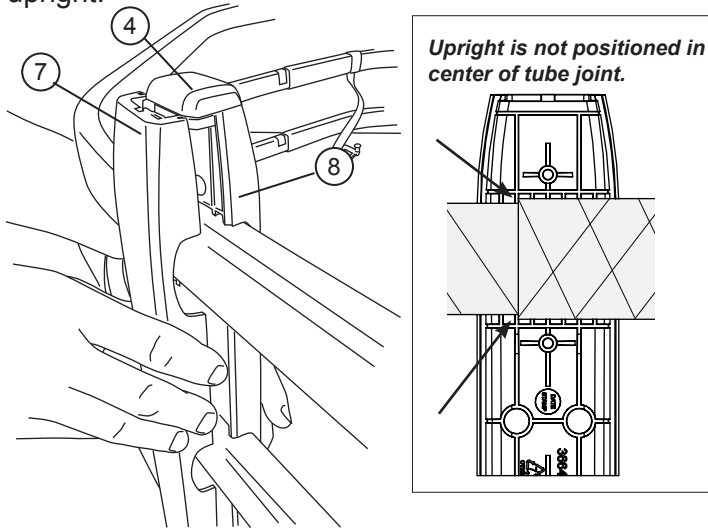

NOTE: The inside of the upright is stepped to fit correctly around the small and large diameter tubes.

7

Tighten PT-Screws using a T-25 torx driver, starting in the middle of each upright, then the outer screws and lastly the remaining two to evenly tighten.

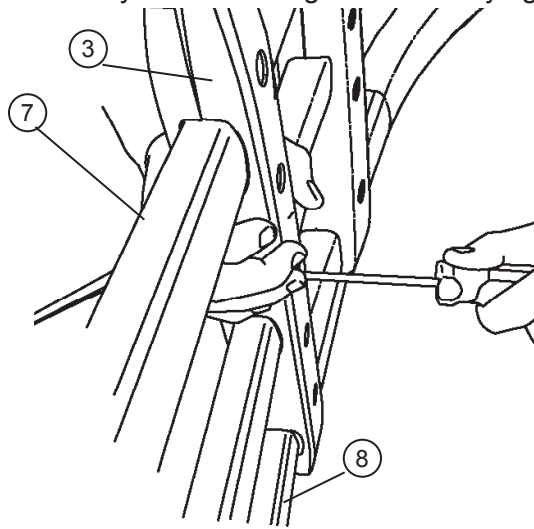

NOTE: Do not over tighten as this may strip out. Fastener will reach a noticeable stopping point.

8

Adjust Strap Buckles to lock into the tailgate when BEDXTENDER is deployed. Your assembly is now complete.

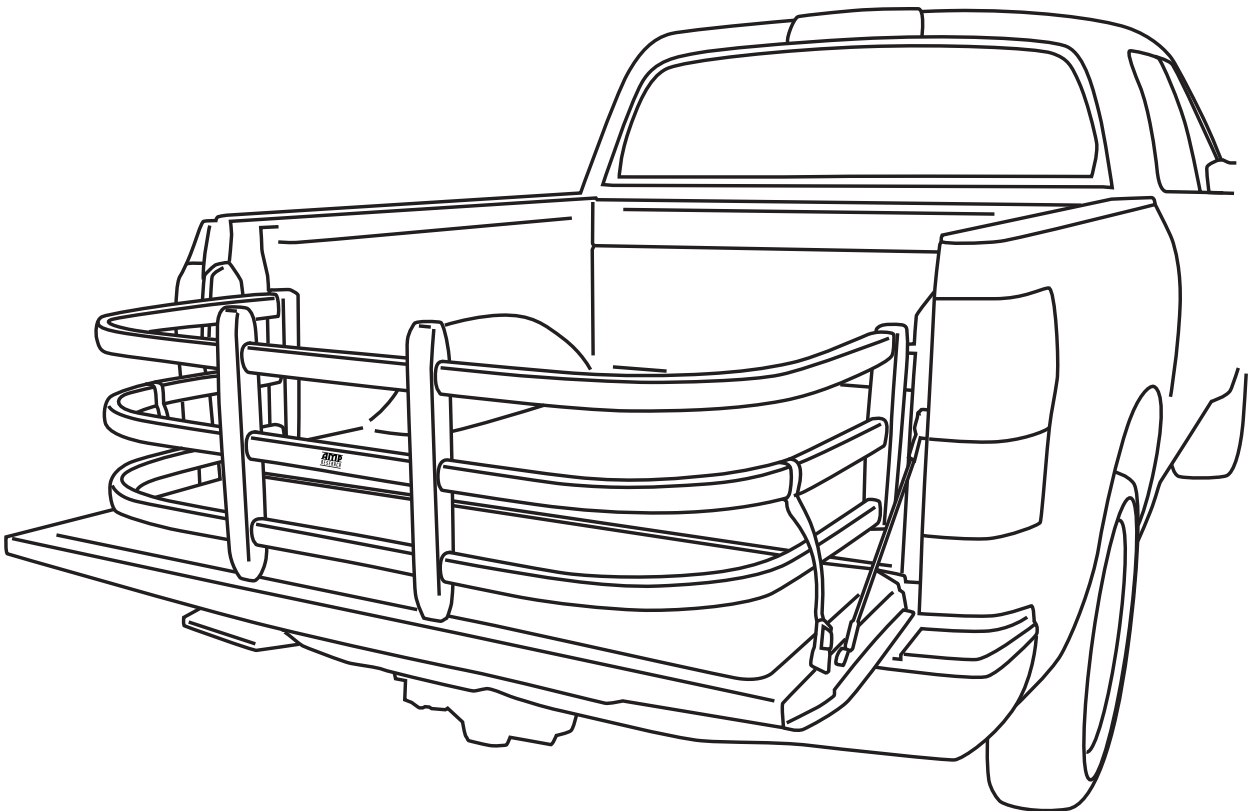

9

For Toyota applications the supplied Strap Buckle Insert must be used.

Remove the PT-Screw with a T20 Torx driver.

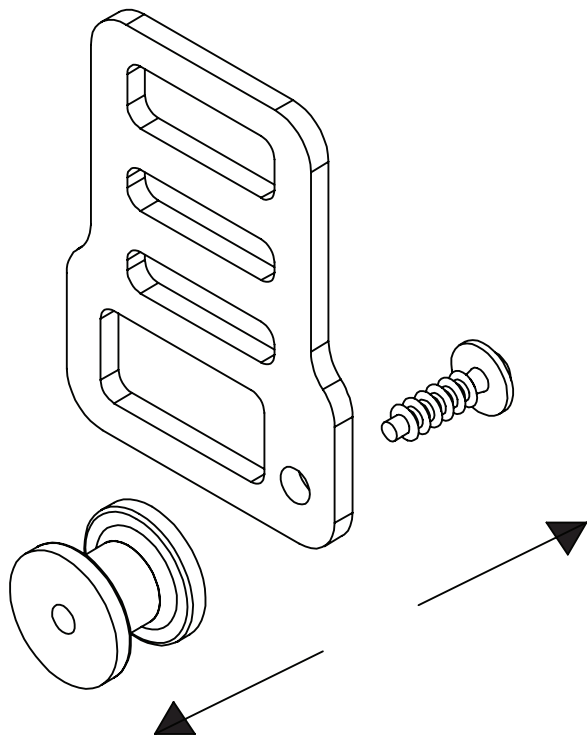

Install Strap Buckle Insert with the provided 10/32 x 7mm socket head cap screw with a 4mm hex key. Repeat for other strap.

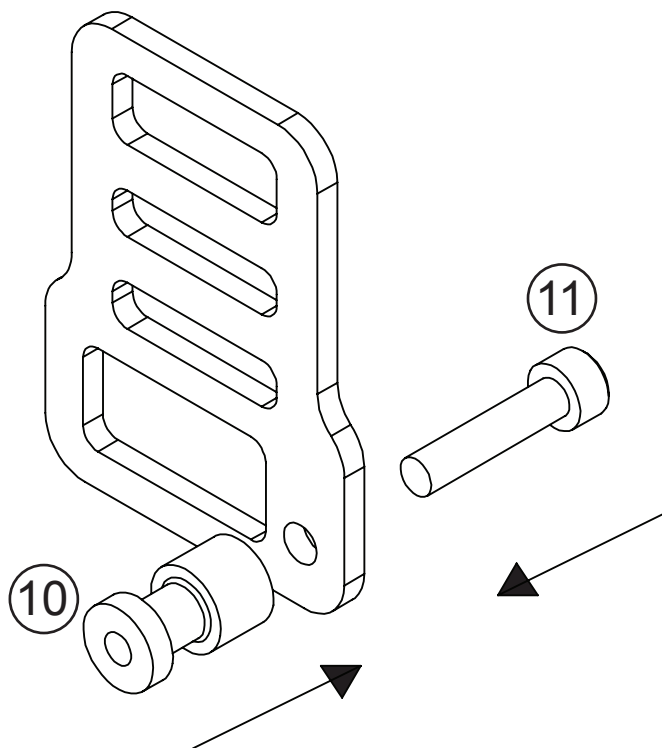

10

11

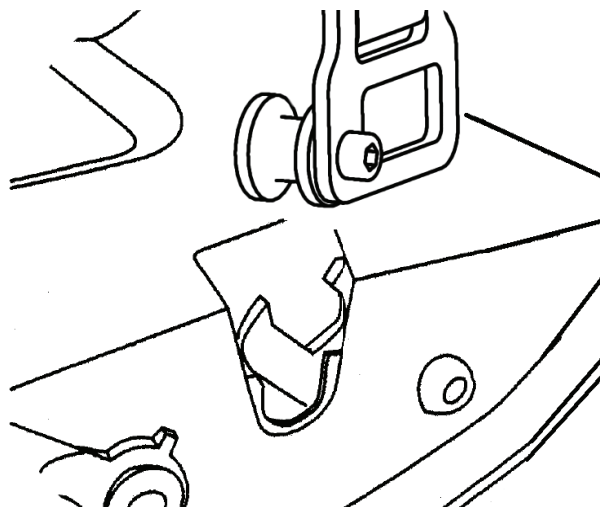

When the BEDXTENDER is at the furthest rear position, push down on the buckle to insert into tailgate latch. Tighten straps. To release, pull tailgate handle.

NOTE: Ensure that buckles are properly inserted into latches by pulling on the straps after both buckles have been inserted.

12



BEDXTENDER HD™ OPERATION

With the tailgate open, place BEDXTENDER pivot pins into the left and right mounting brackets. Rotate to 45 until it drops into place, then lower onto the open tailgate.



Flip BEDXTENDER out to contain cargo in the truck bed when the tailgate is open. CAUTION! 200lb maximum load on open tailgate. Always distribute cargo evenly and properly secure inside bed. Do not secure cargo to the BEDXTENDER or the tailgate.



Before driving, secure BEDXTENDER by locking the provided strap buckles into the truck's tailgate latches. To release, pull tailgate handle. NOTE: Ensure that both buckles are properly locked into the latches by pulling up on each strap.



Flip BEDXTENDER forward and close the tailgate to keep smaller cargo safe and organized.

WARNING

Be sure to read and precisely follow the provided instructions when installing this product. Failure to do so could place the vehicle occupants in a potentially dangerous situation. After installing or reinstalling, re-check to insure that the product is properly installed.



The material that your product is made from can be recycled. Please also consider recycling the packaging that your product came in.



Drill template for BEDXTENDER HD™ mounting brackets

NOTE: FOR TRUCKS WITH BEDLINERS, USE THIS TEMPLATE ON TOP OF BEDLINER. DO NOT CUT BEDLINER!

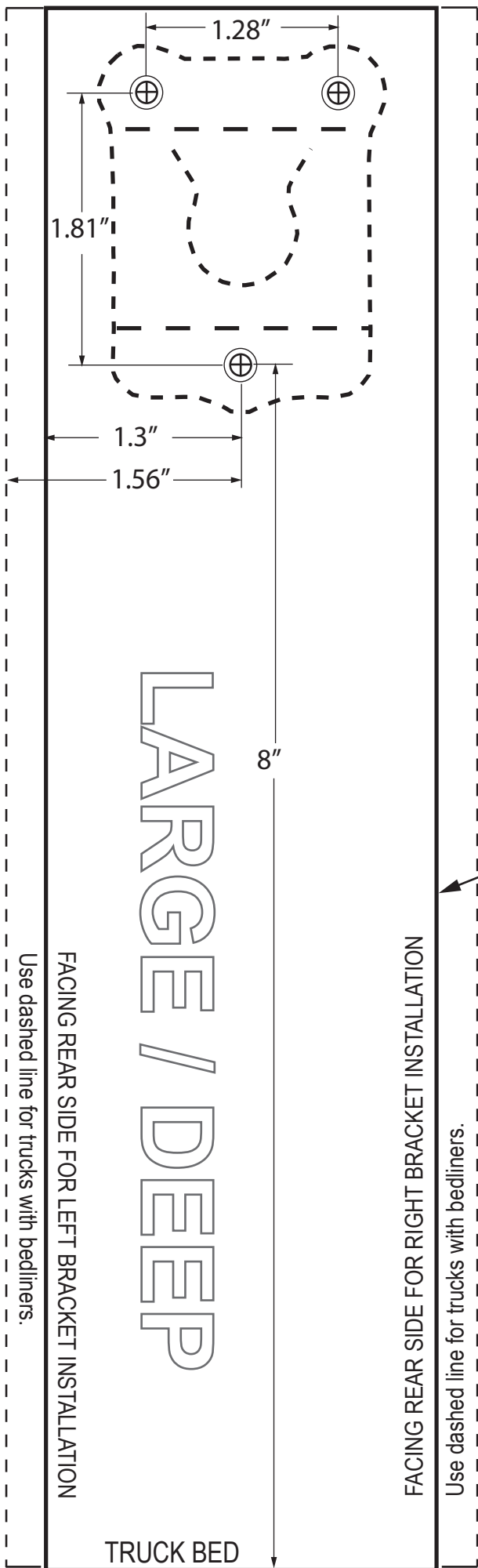

Cut or fold along solid lines.
(Dashed lines for trucks with bedliners.)

Drill template for BEDXTENDER HD™ mounting brackets

