

PLEASE READ ENTIRE INSTRUCTIONS BEFORE PROCEEDING WITH INSTALLATION

AMP Part #: 74606-01A

Recommended Tools:

- #2 Phillips Screw Driver
- Drill
- 1/8" & 21/64" Drill Bits
- Ratchet
- 13mm Socket & Wrench
- 8mm Socket & Wrench
- 3mm Hex Key Wrench
- Circular File
- Tape
- Thread Locker
- Primer

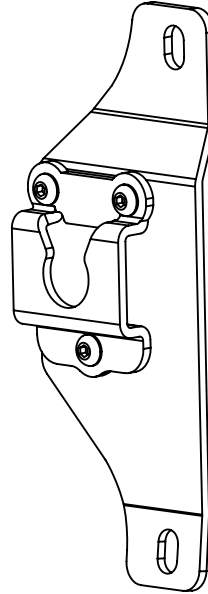
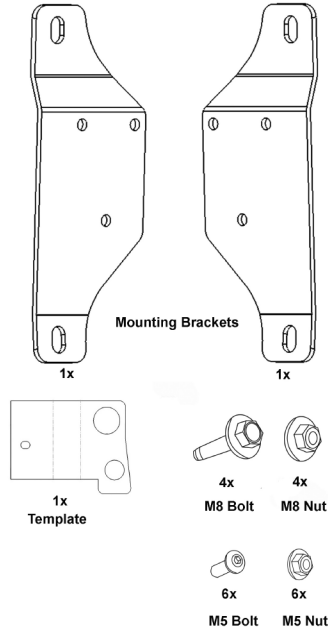

Use the M5 bolts and nuts to fasten the universal bracket to the mounting bracket. Apply thread locker to the tip of the M5 bolt. Torque to 8 ft. lbs. Allow 10 minutes to dry before handling. (Passenger side shown)

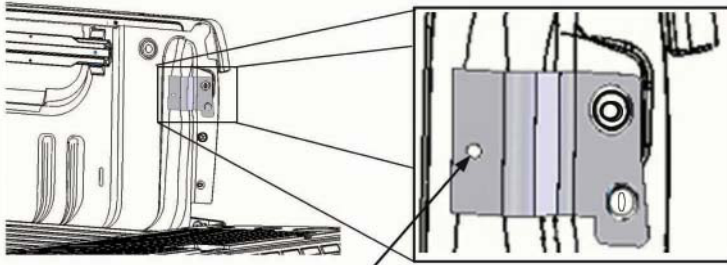

Center Punch & Drill

Remove the 2 Phillips screws that are holding the tail lights in place. Carefully pull back to remove tail lights.

Tape template to vehicle to locate upper hole of Mounting Bracket. Mark (Center Punch) & drill hole with 1/8" drill bit. Remove template and drill out hole with 21/64" drill bit. Use file to remove burrs. Apply primer to edge of hole. Repeat for other side.

1

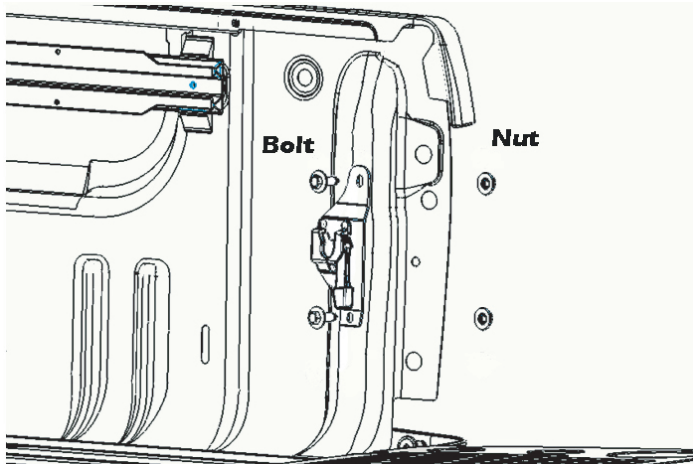

Place Mounting Bracket aligned with top hole. Allow bracket to hang vertically. Mark (Center Punch) location of lower hole using the bracket slot as a template. Remove bracket. Drill hole with 1/8" drill bit then drill out hole with 21/64" drill bit. Use file to remove burrs. Apply primer to edge of hole. Allow primer to dry.

Assemble Mounting Bracket using the M8 bolts & nuts as shown. Tighten & torque to 22ft. lbs. Replace the tail light assembly. Repeat for other side.

2