

Instruction Manual
AME Intl. Part #92000

OTR E/M BAR PUSH TOOL
& O.S.H.A. Required Restraining Device



WARNING

SAFETY PRECAUTION

This product, as well as all Tire Tools, should never be used by person's unless they have been trained properly according to O.S.H.A. Regulation#29CFR 1910.177 entitled "Servicing Single-Piece & Multi-piece Rim Wheels." Copy of the regulation is enclosed or contact this manufacturer.

Note: This tool meets the O.S.H.A requirements as written in #29CFR1910.177 Servicing Multi Piece Rim/Tires

SAFETY CAGE OR RESTRAINING DEVICE

(D) TIRE SERVICING EQUIPMENT

- 1) The employer shall furnish a restraining service for inflation tires on all multi-piece wheels
- 2) The employer shall provide a restraining device or barrier for inflation tires on single piece wheels unless the rim wheel will be bolted onto a vehicle during inflation.
- 3) Restraining devices and barriers shall comply with the following requirements:
 - (i) Each restraining device or barrier shall have the capacity to with stand the maximum force that would be transferred to it during a rim wheel separation occurring at 150 percent of the maximum tire specification pressure for the type of rim wheel being serviced.
 - (ii) Restraining device and barriers shall be capable of preventing the rim wheel components from being thrown outside or beyond the device or barrier for any wheel positioned within or behind the device.
 - (iii) Restraining devices and barriers shall be visually inspected prior to each day's use and after any separation of the rim wheel components or sudden release of contained air.

DEMOUNTING

- 1) Depending on the type of tire crane you are using, you may need to make some small modifications to the crane hook hole in the end of the crane to accept the #92000 mount bracket
- 2) When the #92000 bar is attached to the end of the tire crane, it will swing down with the feet pointing to the ground. As you lift the bar with the crane, insert a lever bar (A) or a tool (KenTool#T23A) as per Figure 1. As you raise the tire crane, push down on the lever (A) to align the bar and the feet from 9 o'clock to 3 o'clock. Once you have the alignment, release the lever bar (A) and allow the feet to point towards the ground.

- 3) Adjust the push feet (B) and (C) to fit the diameter of the rim. Feet should rest against the bead seat band, item (D).
- 4) **CAUTION:** Deflate the tire completely and run a wire through the valve to assure all air is out of tire.

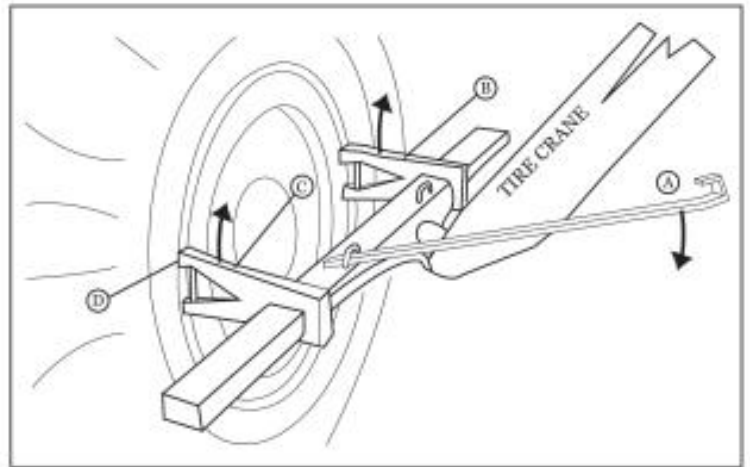

Figure 1

- 5) The #92000 can now be raised into position with the crane and controlled with the lever bar (A). Using the crane control, apply a slight amount of pressure against the bead seat band to push the bead seat band back. Hold it back to remove the o-ring and lock ring.
- 6) Once you have the o-ring and lock ring removed, proceed with normal bead breaking process and demounting of tire.
- 7) After you have mounted the tire and reassembled the rim assembly, it is time for inflation.

#92000 USED AS SAFETY CAGE/ RESTRAINING DEVICE

O.S.H.A. requires that a safety cage or restraining device be used to keep the rim parts from blowing off during inflation; the #92000 acts as a safety cage.

- 1) Before attempting inflation, position the #92000 bar and feet onto the bead seat band with the tire crane.
Apply a slight amount of pressure.

DO NOT USE TOO MUCH PRESSURE, AS TO PUSH THE BEADSEAT BAND OFF THE O-RING.

- 2) Attach an inflation hose to the tire valve and begin inflation. As the tire bead comes out and a seal is effected, decrease the pressure on the crane slightly, making sure the feet **(B)** and **(C)** stay in place in case of a rim separation. **STAY OUT OF THE TRAJECTORY OF THE RIM PARTS. USE A CLIP-ON AIR CHUCK WITH AN IN-LINE INFLATOR AT LEAST 8' LONG.** Before removing the #92000 restraining bar, be sure all rim parts are properly seated in their intended positions.

