



AME INTERNATIONAL

# Instruction Manual

## Manual Impact Bead Breaker

### Product #71026





AME INTERNATIONAL

## CAUTION:

**READ AND FOLLOW ALL WARNINGS, CAUTIONS AND INSTRUCTIONS ASSOCIATED WITH THE PROPER USE OF THIS PRODUCT, FAILURE TO COMPLY COULD RESULT IN DEATH, BODILY INJURY AND/OR DAMAGE TO EQUIPMENT.**

*This product as well as all tire tools, should never be used by persons unless they have been trained properly according to the O.S.H.A. regulation #29CFR 1910.177 entitled "Servicing Single-Piece & Multipiece Rim Wheels". Copies of this regulation can be obtained by contracting this manufacturer.*

## Instructions

1. Choose either an air impact or air ratchet. An air ratchet is preferred for hard to reach areas.



*Air Impact vs. Air Ratchet*

**If using a high torque air impact, set the gun to a lower setting.**

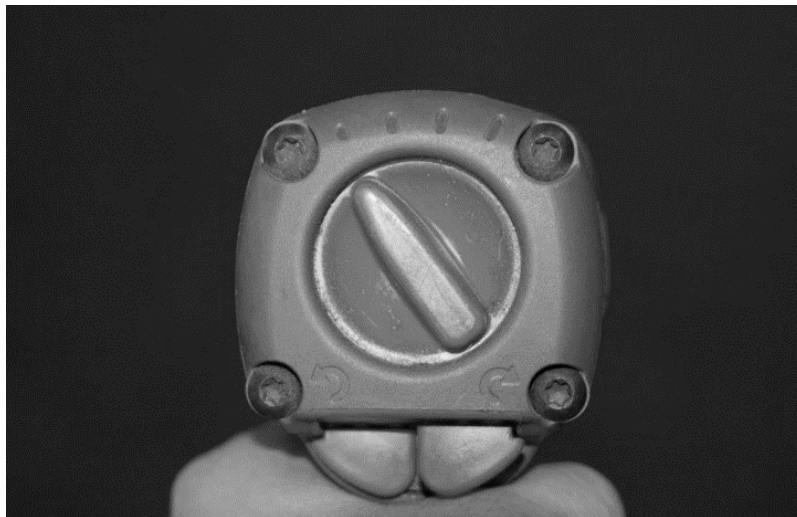



2. Insert the Impact tool counter-clockwise onto the grapple hook drive bolt and begin to Impact the tool into position, use the handle to guide the wedged feet between the rim edge and tire bead.

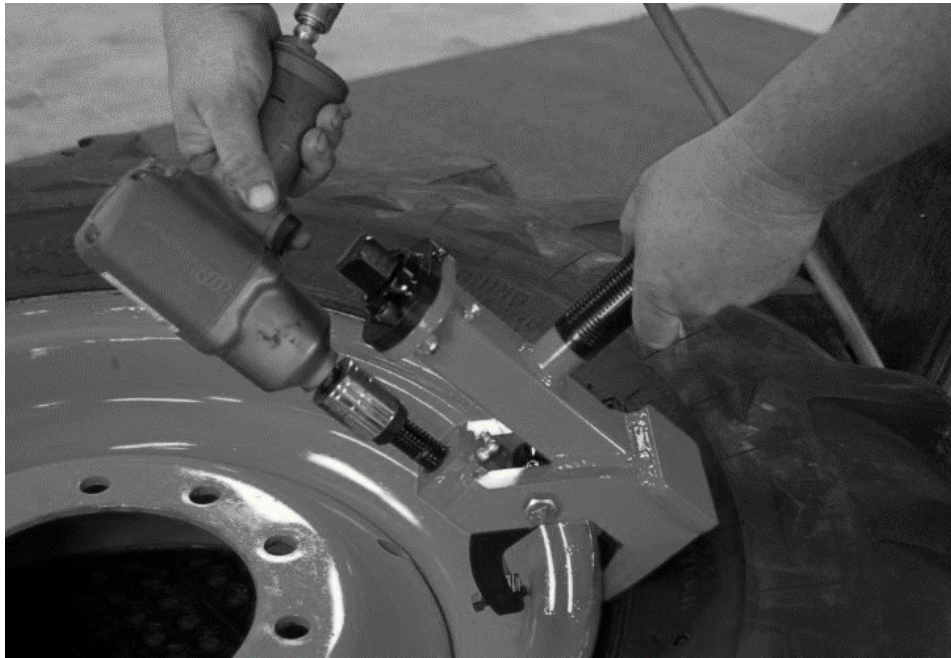

3. Impact the drive bolt until the tool is in an upright position and the wedge feet are secured between the bead and rim.

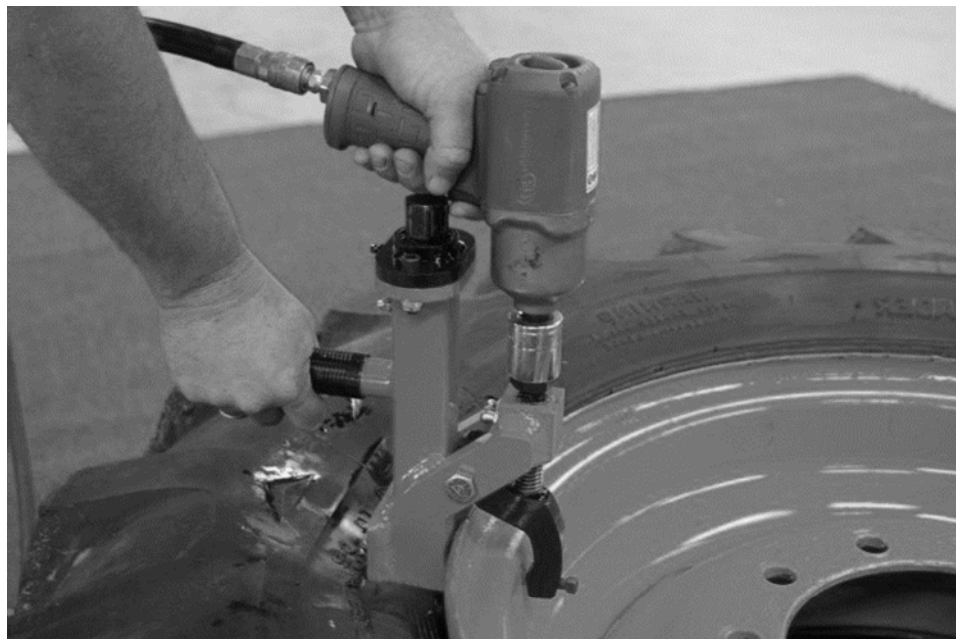

4. Impact the wedge foot drive bolt counter-clockwise until it strips the tire bead free of the rim.

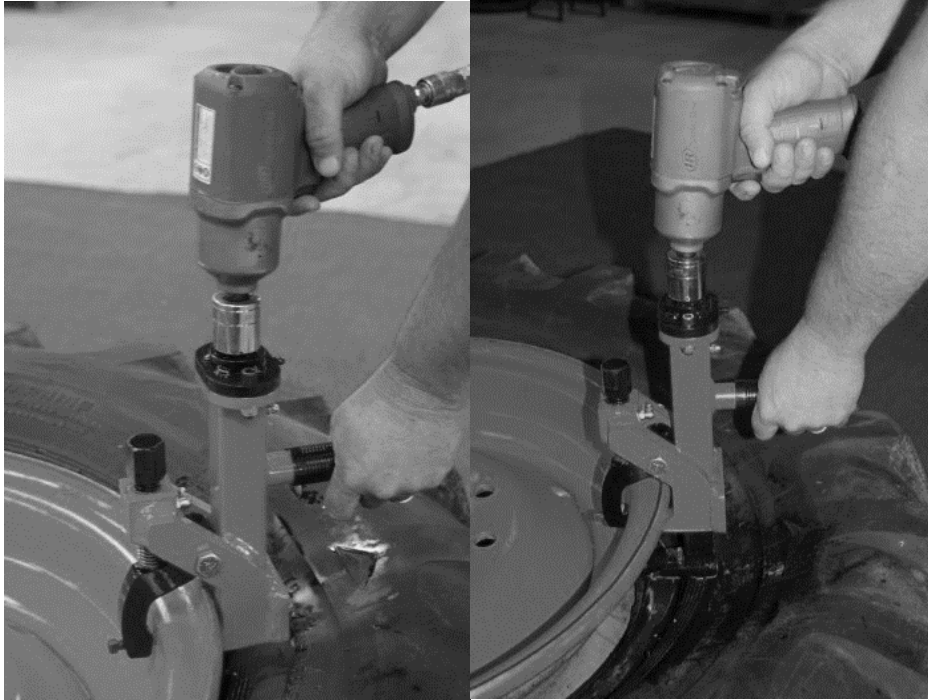

5. Retract foot by reversing impact on wedge foot, then retract grapple hook by reversing drive bolt, finally, remove tool from rim.

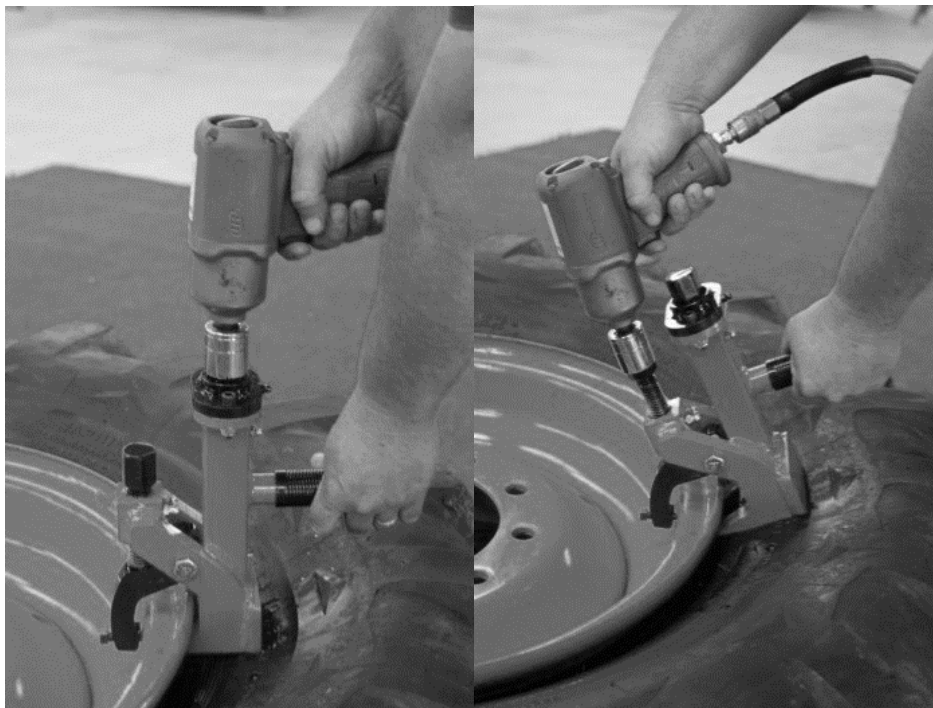



### Parts Breakdown & Parts List

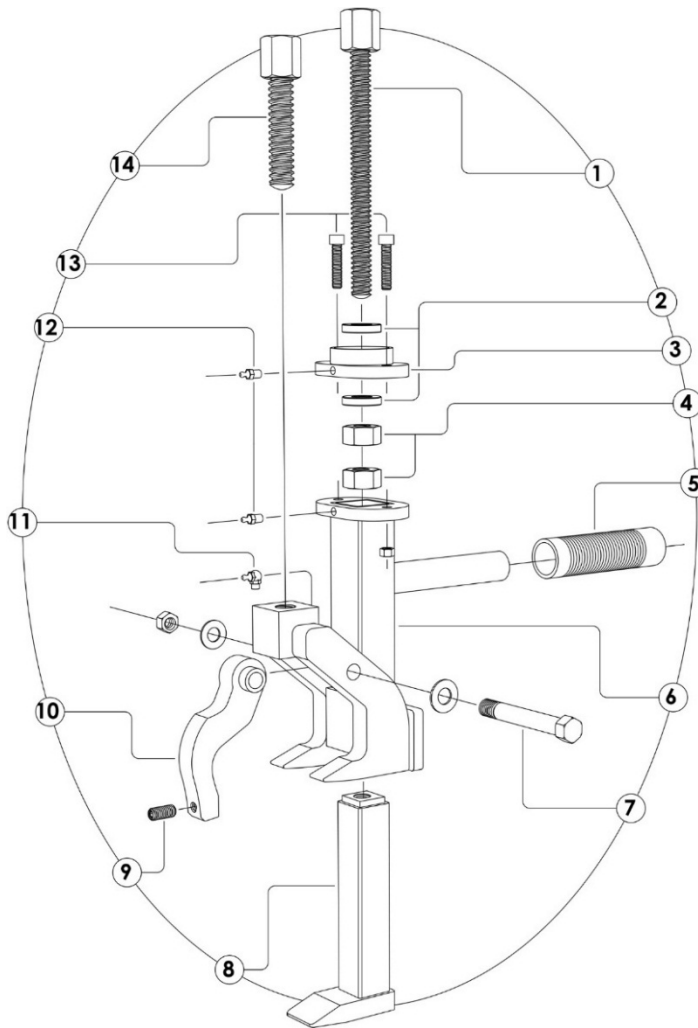

Part #	Description	Part #	Description
1	Main Drive Bolt.	8	Bead Pusher
2	Thrust Washers (x2)	9	3/8" set screw
3	Top Mounting Flange for Drive Assembly	10	Grappling Hook
4	Locking Nuts (x2)	11	Right Angle Grease Fitting
NOTE: Number 1-4 make up the Drive Assembly (this is assembled separate of the main body of the tool prior to its being attached.)			
5	Plastic Handle	12	Straight Grease Fitting (x2)
6	Main Housing Weldment	13	Flange Mounting Bolt Assembly (x2 5/16" bolts; x2 5/16 locking nuts)
7	Pivot Bolt Assembly (x1 1/2 in. Bolt; x2 1/2 in. Flat Washers; x1 1/2 in. Locking Nut)	14	Secondary Drive Bolt for Grappling Hook