



Ladder Installation Instructions

P/N 210578: 2015+ Ford Transit Rear Door Ladder, Driver's Side

Before you begin:

- *Stainless steel hardware may bind together when tightening — apply an anti-seize assembly lubricant to the threads of each bolt before assembly*
- *This installation requires two or more people*

Required Tools:

- Standard and metric wrench set
- Standard and metric socket set
- Torx bit set
- Drill or impact driver
- Dremel
- Isopropyl Alcohol
- Baby Soap or Dish Soap
- Spray Bottle
- Clean Rag
- Squeegee (or old credit card)
- Vice grips



Included Hardware:

<i>P/N</i>	<i>Description</i>	<i>Quantity</i>
70344	5/16"-18 x 1" Button Head Bolt, BLACK OXIDE	4
70446	5/16"-18 x 1 1/4" Button Head Bolt, BLACK OXIDE	2
70448	3/8" ID Washer, 1/8" THK, BLACK OXIDE	4
70345	5/16" ID Washer, BLACK OXIDE	12
70346	5/16"-18 Nylon-Locking Nut, BLACK OXIDE	6
400999	Impact Resistant Protective Tape	9"

Additional Parts:

<u>PN</u>	<u>Description</u>	<u>Quantity</u>
301249	Upper Hinge Bracket	1 ea
301250	Lower Hinge Bracket	1 ea

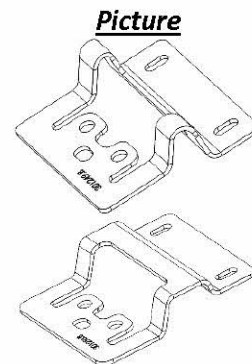

301496

Inner Driver Door Bracket,
Driver

1 ea

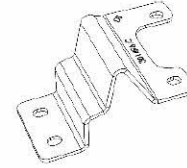

Ladder Installation:

1. Cut the supplied protective tape into one - 6" section and one - 3" section. Round all corners.
2. Apply the protective tape to each location, one at a time, using the following wet application technique described below.
3. Prepare the surface for protective film application (wet application technique):
 - a. Clean the area around each hinge with isopropyl alcohol and rag.
 - b. Wash your hands thoroughly.
 - c. Do not apply in direct sunlight
 - d. Apply in temperatures above 60°F.
 - e. Create two separate wetting solutions:
 - i. Soap/water: ~95% water / ~5% soap
 - ii. Alcohol/water: ~75% water, ~25% isopropyl alcohol
4. Spray the surface thoroughly with soap/water solution and do not wipe down surface.
5. Remove the liner from the protective tape while spraying the adhesive side with soap/water solution.
6. Apply the protective tape to the outside of the door (Figure 1). At the upper or lower hinge location, leaving approximately 1/2" of tape overhanging to be wrapped around the edge of the door. Leave the tape overhanging for now.

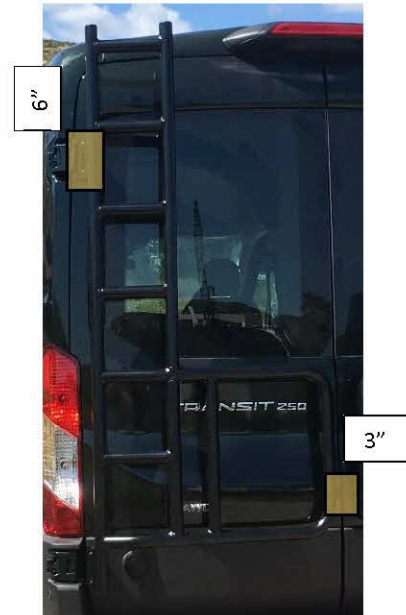

Figure 1: Locations of Protective Film Application

7. Use squeegee all air bubbles out starting at adhered edge.
8. Use the alcohol/water solution to speed up adhesion at one edge (lift section up and spray adhesive side) as needed.
9. Wrap remaining protective tape around the door underneath hinge if possible.
10. Install the upper hinge bracket by:
 - a. Have someone help support the weight of the door throughout the entire bracket installation.
 - b. Remove the three bolts connecting the hinge to the door.
 - c. Rotate hinge enough to allow the bracket to be installed around the hinge (Figure 2).



Figure 2: Upper Hinge Rotated Away from Door

- d. Install the hinge around the hinge in the correct orientation (Figure 3).



Figure 3: Bracket Installed Over Factory Hinge

- e. Rotate the hinge and bracket back into position against the door.
- f. Use the factory hardware to reinstall the hinge/bracket (Figure 4).

PRO TIP: Be sure to center the bracket around the hinge and verify clearances around the hinge while slowly opening and closing the door.



Figure 4: Inside View of Installed Upper Hinge Bracket

11. Install the lower hinge bracket by repeating the process detailed in Step 2 (reference Figure 5).



Figure 5: Inside View of Installed Lower Hinge Bracket

12. Loosen the weather-stripping on the inside of the driver's side door from the bottom up to past the inside handle.
13. Remove the driver's side inside handle by removing the torx bolt (Reference Figure 6).



Figure 6: Driver's Side Inside Handle

14. Remove the upper and lower factory torx bolts as shown in Figure 7. NOTE: Hold the center post with clamp or vice during the installation to prevent the latch falling into the door.



Figure 7: Inner Door Bracket Installed

15. Install the inner driver door bracket using the upper and lower factory torx hardware (See Figure 8).



Figure 8: Inner Driver Door Bracket Installed

16. If needed, cut a relief channel into the ribs on the back of the plastic factory handle with a Dremel. Reference Figure 9. Shave the ribs down about 1/8", or enough to clear the torx bolt head on the inside of the door.



Figure 9: Driver's Side Inside Handle

17. Reinstall the inside door handle over the bracket using the same factory torx bolt.
18. Verify the driver's inside door handle operates as desired. Repeat Steps 16-17 as needed.
19. Mark and cut the weather-stripping to fit around the inner door bracket. On the weather-stripping, cut the channel (attachment to the folded sheet metal) and not the bulb (hollow tube); (Reference Figure 10 & 11).

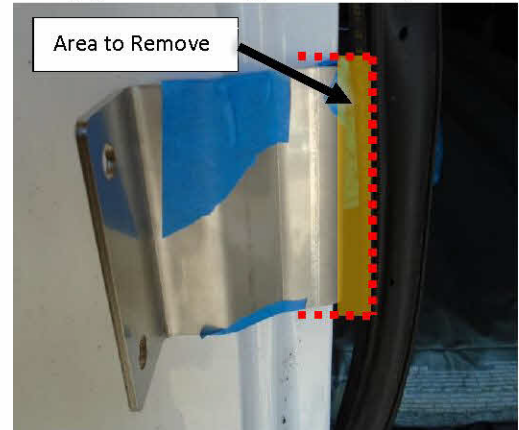

Figure 10: Weather-Stripping Cut to Shape

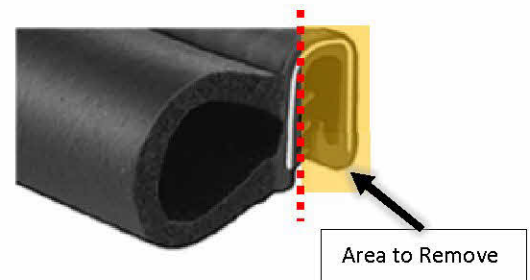

Figure 4: Cross-Section of Weather-Stripping

20. Reinstall weather-stripping over the bracket ensuring cut section lines up with bracket as shown in figure 12.



Figure 12: Installed Weather Stripping After Modification



21. Loosely install the rack onto the upper, lower, and inner brackets using the provided 5/16"-18 bolts, washers, and nuts. Use the 1" bolts for
22. the outer brackets and the 1 1/4" bolts for the inner bracket.
 - a. Tighten the upper and lower **hinge** brackets first.
 - b. There should be a small gap at the center bracket before it is fully tightened (0-1/8"). If the gap is larger, than 1/8", use the provided 1/8" THK washers as shims (PN: 70448) to close the gap to $\leq 1/8"$ (See Figure 13).



Figure 13: Gap between bracket and product

23. Verify the hinge brackets and inner door brackets have appropriate clearances while slowly opening and closing both rear doors.
24. Check mounting hardware after first 100 miles of driving and periodically after to verify hardware has not become loose from vibration.
25. Your new Aluminess tire rack is now installed, enjoy



Bolt-On Box + Tire Carrier Installation Instructions

P/N 210574: Rear Door Bolt-On Box/Tire Carrier

Before you begin:

- **Maximum load capacity is 100 lbs on box/tire rack once installed.**
- Product must be used in conjunction with Transit Rear Door Ladder (P/N 210534) or Sprinter Rear Door Ladder (210572); sold separately.
- Stainless steel hardware may bind together when tightening — apply an anti-seize assembly lubricant to the threads of each bolt before assembly

Required Tools:

- Standard and metric wrench set
- Standard and metric socket set
- Hex key (Allen wrench) set

Included Hardware:



P/N	Description	Quantity
70348	3/8"-16 x 1.25" Carriage Bolt, SS	2
70028	3/8" Washer	2
70024	3/8"-16 Nylock Locking Nut	2
70270	3/8"-16 x 5" Socket Head Bolt, Zinc	1
70271	3/8 Internal Tooth Lock Washer, Zinc	1
70246	Antiseize Bolt Lubricant Packet, 2g	1
401006	5/16" Allen Key	1

PN	Description	Quantity
350660	Bolt-On Folding Step Mounts (pre-assembled)	3 ea
350662	Bolt-On Tire/Box Supports	2 ea
301506	Universal Tire Mount, Wedge Mount	1 ea
401004	Universal Tire Mount, Wheel Wedge	1 ea
401005	Polyethylene Plastic Snap-in Round Plug	1 ea
350616	Universal Tire Mount, Bracket	1 ea

Picture

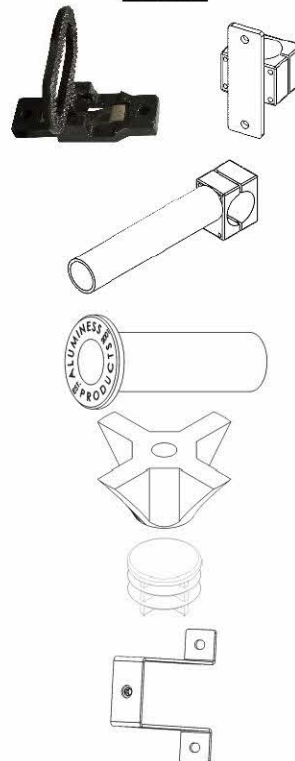

Tire Rack Installation:

1. Install the Aluminess Rear Door Ladder (P/N 210543) per the separately provided installation instructions.
2. Loosely install the bolt-on tire/box supports onto the bottom crossmember of the rack as shown in Figure 1.



Figure 1: Bolt-On Supports Loosely Bolted to Lower Crossmember

3. Starting with support closest to tail light – sliding support as close to the tail light as possible and then rotate into desired position and tighten.

PRO TIP: Reference Figure 2 for suggested mounting orientation.

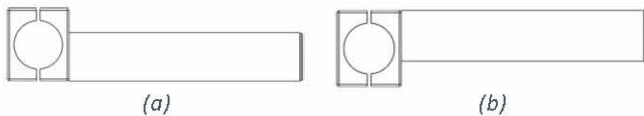

Figure 2: Suggested Orientation for Tire (a) and Box (b)

4. Repeat for the support opposite the center post, being sure that the spacing is equal from the center post, and the orientation is the same for both supports.
5. Loosely fasten the Tire Mount Bracket to the slotted channel using the 3/8" carriage head bolts, washer, and nuts to mount. Reference Figure 3.

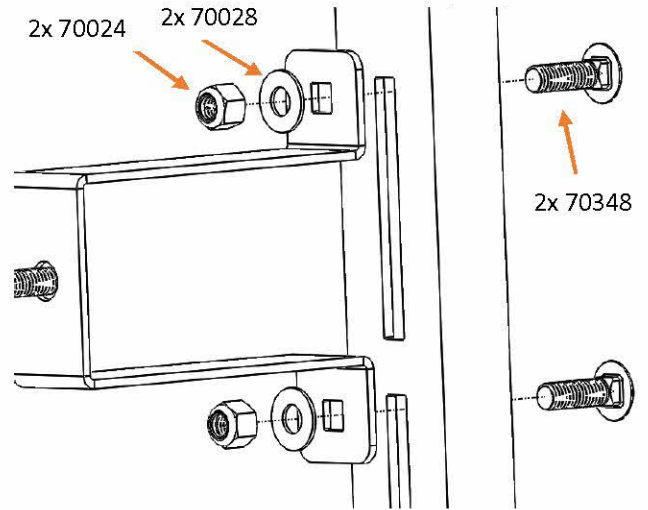

Figure 3: Mounting Tire Bracket

6. Place the mounting bracket in the correct location by placing your tire on the tire supports and then adjusting the bracket vertically until the center hub aligns with the center of the bracket.
7. Once the bracket is in place remove the tire and tighten the hardware holding the bracket in place.
8. Place the tire on tire on the support stands and mount the wheel wedge, wheel wedge mount, 5" socket head bolt, and locking washer to secure the wheel into place with the provided Allen key. Reference Figure 4 and 5.

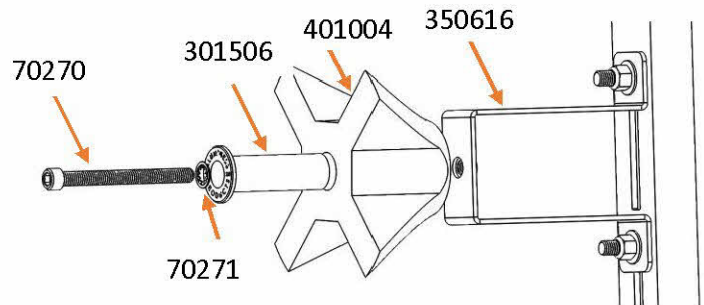

Figure 4: Wheel Wedge Assembly



Figure 5: Tire Mount Assembled

9. Once everything is securely fastened insert the snap in plug into the wedge mount. Reference Figure 6.

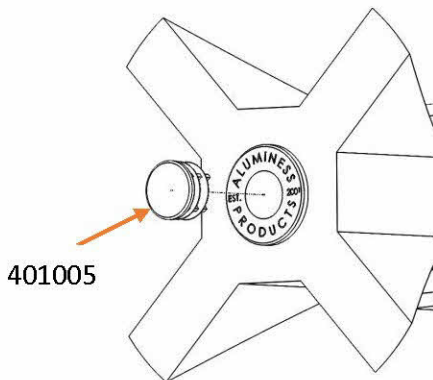

Figure 6: Snap in round plug

10. Bolt the fold-down step on the outside rail of the ladder in desired locations. Reference Figures 7.

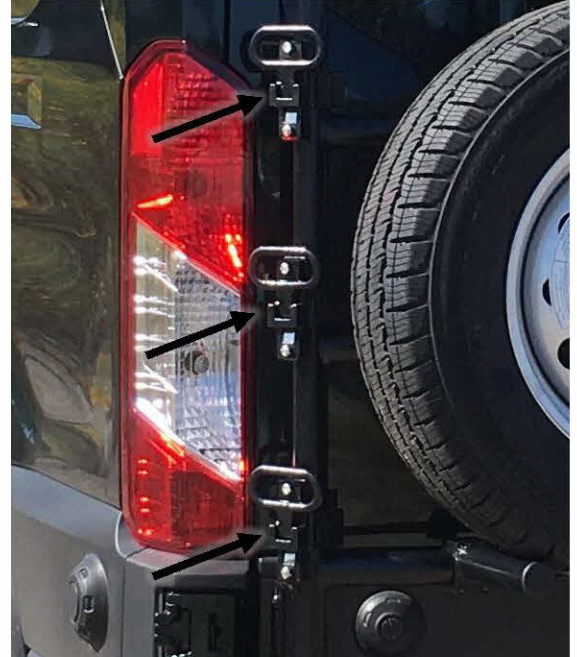

Figure 7: Step Mounting Locations

11. Check mounting hardware after first 100 miles of driving and periodically after to verify hardware has not become loose from vibration.
12. Your new Aluminess tire rack is now installed, enjoy!