



Ladder Installation Instructions

P/N 210494 & 210495: 2007+ Mercedes Sprinter Track Mounted Ladder

Before you begin:

- *Stainless steel hardware may bind together when tightening — apply an anti-seize assembly lubricant to the threads of each bolt before assembly*
- *Over tightening bolts can cause the hardware to break due to excessive force. When tightening, be sure to apply only the recommended torque.*
- **Threaded inserts (350483) and lower attachment bracket (350558) will not be covered under warranty. Replacements can be ordered for additional cost.**
- *The ladder is designed to fit in front of the rear wheel on the driver's side of the van.*
- *Factory or aftermarket roof tracks must be installed before to ladder.*

Required Tools:

- Standard and metric wrench set
- Standard and metric socket set
- Standard hex key (Allen wrench) set
- Drill with drill bits

Included Hardware:

PRE-KITTED 350452

P/N	Description	Quantity
70008	¼"-20 Nylon-Locking Stainless Steel Nut	7
70009	¼"ID Stainless Steel Washer	10
70019	5/16"-18 Nylon-Locking Stainless Steel Nut	2
70020	5/16" ID Stainless Steel Washer	2
70060	¼"-20 x 1" Stainless Steel Button Head Screw	3
70201	5/16"-16 x 1" Stainless Steel Socket Cap Screw	2
70246	Antiseize bolt lubricant packet, 2g	1

Additional Parts:

PN	Description	Quantity
350567	Upper Attachment "L" Brackets	2
350558	Lower Attachment Bracket	1
350483	Threaded Insert	2

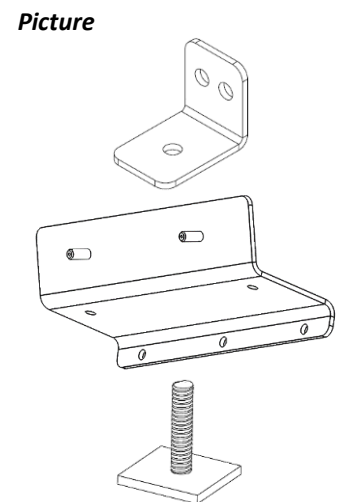
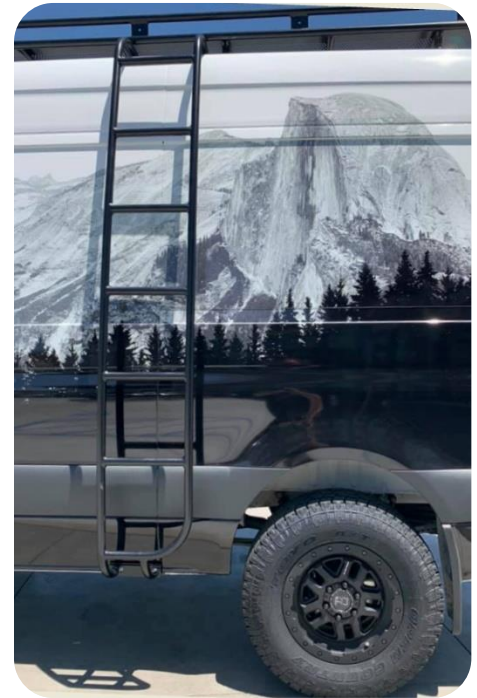

Ladder Installation:

NOTE: If you purchased an accompanying pair of nerf bars, it is easier to install the **ladder** first.

Upper Attachment Installation:

1. Slide both threaded inserts into the roof track from the rear of the vehicle with studs pointing upwards.
2. Install the "L" brackets onto threaded inserts using the centered, pre-drilled holes and thread on washer and nut. Leave the "L" brackets loose enough to slide back and forth (see Figure 1) NOTE: Be sure to apply anti-seize to the threaded inserts.

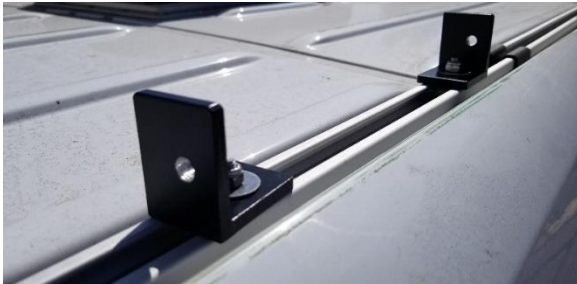

Figure 1: "L" Brackets Installed on Factory/Aftermarket Tracks

3. Position the ladder where you would like it to sit on the vehicle.
4. Clamp the top of the ladder to the L-brackets using C-clamps or spring clips with "L" brackets on inside face of ladder (see Figure 2).



Figure 2: Ladder Positioned on "L" Brackets

5. Install the 5/16" bolts, washers, and nuts and tighten by hand—do not torque down bolts yet.

Lower Bracket Installation:

6. With the ladder attached at the top, locate the desired position of the lower attachment bracket.

Ensure the ladder is straight compared to the vehicle before finalizing lower bracket placement.

7. Hold the lower attachment bracket up to the vehicle body using C-clamps or spring clips. Be sure to align the bottom three holes with the pinch weld.



Figure 3: Lower Bracket Installation

8. Using a 1/4" drill bit, make three holes through the pinch weld using the bracket as a template for alignment.
9. Install the 1/4" cap screws, washers, and nuts into the drilled holes. Tighten down bolts to 6 ft-lbs. of torque. NOTE: **BE CAREFUL** to not over tighten and be sure to apply anti-seize to the cap screws.
10. Place ladder against lower attachment bracket making sure the bottom of the ladder aligns over the threaded studs.
11. Install 1/4" washers and nuts onto the threaded studs.
12. While applying downward pressure to the ladder, tighten the 1/2"-20 nuts to 6 ft-lbs. of torque fixing the ladder in place. NOTE: **BE CAREFUL** to not over tighten and be sure to apply anti-seize.



Figure 4: Lower Bracket Tightening Technique.

13. Visually inspect the position of the ladder—if satisfied, tighten down the top bolts to 6 ft-lbs. of torque for the 1/4" hardware and to 11 ft-lbs of torque for the 5/16" hardware.