



FRONT BUMPER INSTALLATION INSTRUCTIONS **2007-2011 DODGE / MERCEDES SPRINTER**

Please read before beginning

- *Stainless steel hardware may bind together when tightening—It is recommended that you apply an anti-seize assembly lubricant to the threads of each bolt before assembly*
- *This installation requires two people*

Required tools

- Standard wrench set
- Torx (6 point star head) wrench set
- Flat head screwdriver
- Hammer
- Putty knife
- Razor or box cutter
- Drill, with 1/2" drill bit
- Shears or tin snips



Included hardware

Quantity

- | | |
|---|---------|
| • 70103 – 1/2"-13 x 2 1/2" Hex head bolt | 4 |
| • 70109 – 1/2"-13 x 5" Hex head bolt | 2 |
| • 70035 – 1/2" ID Flat washer | 12 |
| • 70033 – 1/2"-13 Nut with nylon locking insert | 6 |
| • 70060 – 1/4"-20 x 1" Button head socket cap screw | 2 |
| • 70008 – 1/4"-20 Nut with nylon locking insert | 2 |
| • 70102 – M8-1.25 x 65mm Hex head bolt | 6 |
| • 70101 – M8-1.25 Hex nut | 6 |
| • 70027 – 3/8" ID Thick washer | 6 |
| • 70111 – 5/16" ID Split lock washer | 6 |
| • Steel support brackets | 2 pairs |
| • Fairlead cover | 1 |
| • 70008- 1/4-20 Nylock Nuts SS | 2 |
| • 70039- 1/4 x 7/8 Fender Washer SS | 4 |
| • 70060- 1/4-20 x 1" Button Head Bolt SS | 2 |
| • Keys for winch compartment | 1 set |



Installation Instructions

1. To remove the stock bumper, begin by propping up the hood in order to access the grill
2. Remove the four torx-head bolts holding the grill on (indicated by the arrows in figure 1) – do not discard these, you will need them to put the grill back on
3. Once the bolts have been removed, the plastic clips holding the grill on must be released—pull the grill towards you gently to allow some space to put your hand behind it and reach the clips
 - To release the two large clips on the sides of the grill seen in figure 2, squeeze the top and bottom together (indicated by arrows) and push down—be careful, these break easily
 - To release the three bottom clips holding the grill to the bumper cover as seen in figure 3, push down on the tab sticking out from the grill while pulling the grill gently towards you—these
 - The use of gloves is strongly recommended here, as the metal heat exchanger tubes behind the grill are fairly sharp

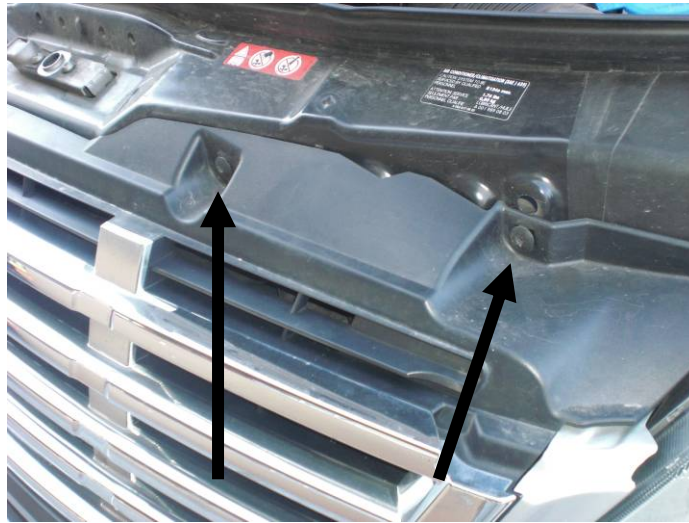

Figure 1: Stock grill hardware

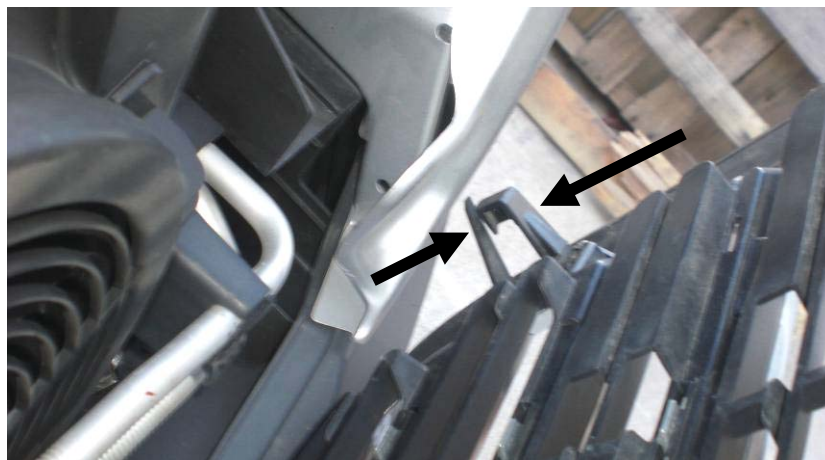

Figure 2: Grill retaining clips

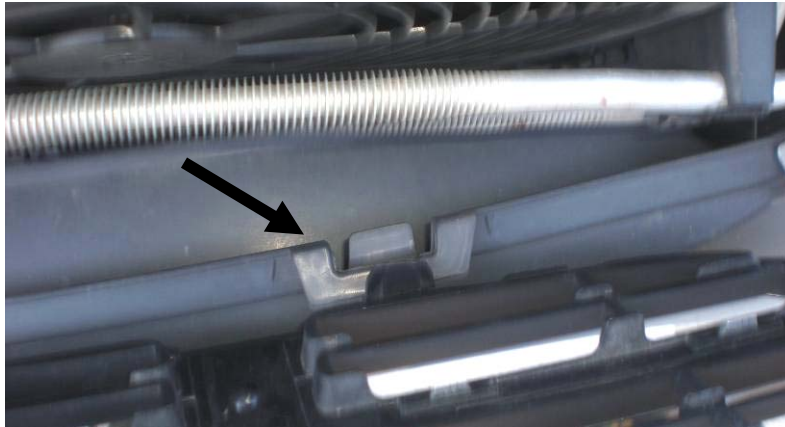

Figure 3: Lower grill retaining clips (top view)

4. Remove the plastic fasteners holding the bumper cover to the fender liners—there are three inside the fender and two underneath the front edge of the bumper cover on each side as seen in the photos below—in order to remove them, pry up on the center part of the fastener with a flat head screwdriver until it pops up, then the entire fastener may be removed by hand (see picture below)



Figure 4: (Clockwise from top left) Plastic fastener location in fender well; Plastic fastener locations under leading edge of bumper; Plastic fastener closed (left) and open (right)

5. Remove the metal trim pieces underneath the headlight by first removing the two torx screws holding them in (see figure 5) and then releasing the clips holding them to the bumper cover—the

best way to release these clips is to stick a flat object (such as a pry bar or putty knife) between the bumper cover and headlight trim and push down to release the clip—be careful not to damage the headlight or headlight trim pieces!

6. Once all of the fasteners are disengaged from the headlight trim piece, carefully lift up on the outside edge where it attaches to the fender and pull towards the front of the car to disengage it—you may have to squeeze the two plastic clips in order to get them to release—again, be careful not to damage the headlight or trim piece!



Figure 5: Headlight trim piece torx bolts

7. Now remove the plate cover shown in the image below and to the left; there are four bolts holding it on—there may be a sensor attached to it; make sure to disconnect the wiring connector
8. Once the plate cover is removed, the two bumper cover mounting bolts are exposed (indicated by circles below and to the right); these may be removed with a 13mm wrench—There are also two large torx-head bolts on top which must be removed, indicated by arrows below



Plate cover (left) and plate cover removed (right) showing bumper cover fasteners

10. Now simply slide the bumper cover forward to remove it—if resistance is encountered, stop and check for fasteners still attached; the bumper should slide off easily
11. Now the bumper should be exposed; there are four bolts on each side which must be removed, use a 13mm wrench—There may be some frame sealant stuck on the bolt heads; Use a box cutter to scrape it off in order to fit a wrench on the head of the bolt



Figure 6: Stock bumper, passenger side

12. Once the bolts are removed, the bumper usually is stuck to the frame of the vehicle because of the frame sealant; In order to release the bumper, gently tap on the seam between the bumper and the frame using a putty knife and hammer as shown in figure 7 below—Make sure there is someone supporting the bumper as you do this so that it does not fall and cause injury once released; once the seal is broken between the bumper and frame, pull the bumper forward on that side—the leverage should release the seal on the opposite side as well



Figure 7: Releasing stock bumper with hammer and putty knife

13. Take the supplied M8 bolts and thread them into the frame horns as shown in the figure below; insert three per side, with no bolt installed on the upper outer hole as shown—tighten these bolts down



Figure 8: M8 bolts installed on passenger side frame horn

14. Lift up the bumper and install it on the frame horns, aligning the holes in the rear of the bumper with the bolts which were just installed—it should slide on easily
15. Check that the bumper is centered on the car and level
16. With someone supporting the bumper, install the supplied M8 nuts with 3/8" washers on the bumper surface, then 5/16" split washers beneath the nut, then snug them down as shown in the image below—do not tighten down fully, as you may want to remove them for a later step



Figure 9: Frame mounting bolts with lock washers and 3/8" washers installed

17. With the bumper hardware secured, bolt on the steel support brackets as shown in figure 9 below, using the supplied 1/2" hardware—the slotted hole aligns with the hole in the back surface of the bumper, and the smaller hole should be against the lower surface of the side of the frame—do not tighten these bolts down fully yet, you may have to move the bracket slightly

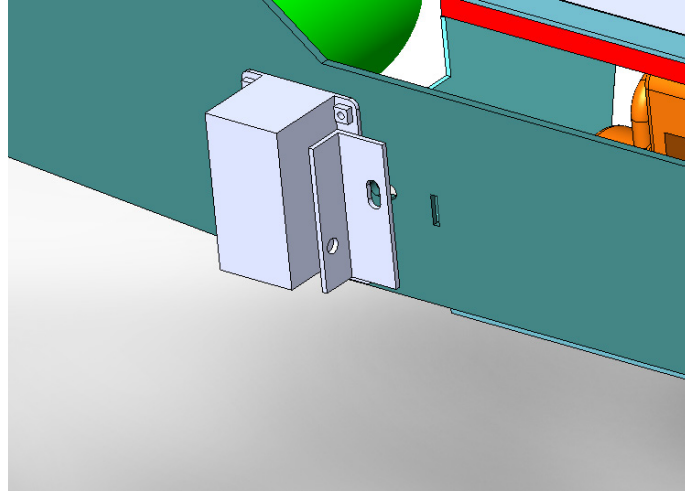

Figure 10: Drawing of steel support bracket installation



Figure 11: Steel support brackets bolted to frame

18. Using a 1/2" drill bit, drill through the lower holes, into the frame in order to create a hole for the 5" long bolt to pass through—a couple of ways to accomplish this are discussed below
- The simplest and most accurate method is to make sure the brackets are bolted securely to the bumper, and drill as straight as possible through the lower hole in the bracket and into the frame—once the hole has been made, pull the drill out and do the same to the other side of the frame—therefore, you will be drilling 4 separate holes; Slide the 5" bolt through the holes to make sure they line up right—if they don't, take the drill and ream the holes out slightly larger



- b. The second method is more time-consuming and less accurate, but is practical if you do not have a drill which is small enough to fit in this working space—First, with the brackets firmly secured, mark the lower hole locations on the frame using a center punch or scribe; make sure you mark the exact hole center—Then, remove the brackets and bumper and drill the holes out which were just marked—Reinstall the bumper and brackets and see if the bolt passes smoothly through all of the holes—If not, ream out the holes until the bolt is able to pass through the brackets and frame hole
19. Install the 5" bolt through the brackets and frame using the supplied washers and nylon locking nut, then tighten down all of the 1/2" hardware
20. Tighten down the M8 hardware holding the bumper to the frame
21. If you have a winch, install it now—you will be unable to do so after the following steps
22. The bumper's door is cut in 2 parts—a smaller and a larger part; Install the smaller part in the portion of the door hole which is closest to the radiator, with the tabs facing rearward, bolt it down into the holes in the door frame using the supplied 1/4" hardware as shown in figure 12 below



Figure 12: Bumper door, rear portion installed

23. Re-install the headlight trim pieces, then the grill, making sure the tabs facing upwards from the door are protruding up into the square slots in the lower part of the grill as shown in figure 13 below



Figure 13: Stock grill installed on Aluminess door tabs

24. At this point, you may wish to trim the inner plastic fender liners so that they do not hang down from behind the bumper—simply cut them with shears or tin snips and re-attach any fasteners to insure that they do not hang loosely
25. Install the fairlead cover on the front face of the bumper using the supplied 3/8" hardware—there are two small 1/4" holes in the fairlead cover for mounting a license plate
26. Finally install the other portion of the door, as shown in figure 14 below, and any lights or accessories at this point—the bumper installation is complete



Figure 14: Bumper door installed